

## Effects of the strain transmission from the main board to the installed electronic components

I. Kovtun\*, J. Boiko\*\*, S. Petrashchuk\*\*\*, G. Baurienė\*\*\*\*, K. Pilkauskas\*\*\*\*

\*Khmelnitskiy National University, 11 Instytutska Str., 29016 Khmelniyskiy, Ukraine, E-mail: dr.igorkovtun@gmail.com

\*\*Khmelnitskiy National University, 11 Instytutska Str., 29016 Khmelniyskiy, Ukraine, E-mail: boiko\_julius@ukr.net

\*\*\*Khmelnitskiy National University, 11 Instytutska Str., 29016 Khmelniyskiy, Ukraine, E-mail: svitlana.petrashchuk@gmail.com

\*\*\*\*Kaunas University of Technology, Studentu str. 56, LT-51424 Kaunas, Lithuania, E-mail: genovaitė.baurienė@ktu.lt

\*\*\*\*\*Kaunas University of Technology, Studentu str. 56, LT-51424 Kaunas, Lithuania, E-mail: kestutis.pilkauskas@ktu.lt

**crossref** <http://dx.doi.org/10.5755/j01.mech.22.6.16891>

### 1. Introduction

Most of the modern machines and mechanisms are equipped with electronic packages that include wide range of electronic components and units. One of the major components is represented by printed circuit board (PCB), which mechanically supports and electrically connects electronic components, such as integrated circuits (IC), discrete components, adapters, sockets, connectors etc. Such boards are often called the main boards (MB) or functional printed circuit assemblies.

There are electronic packages exposed to temperature, humidity, vibration and other impacts while in operation what demands environmental protection approaches. They assume using special electronic modules (EM) designed by applying partial or complete PCB substrate coating, encapsulation or sealing enclosure (Fig. 1), which may be used alone or in combination [1]. Such electronic modules are widely installed on board of land transport, airplanes, rockets, ships, trains etc.

PCBs substrate and electronic components may sustain variety of deformations caused by as manufacturing

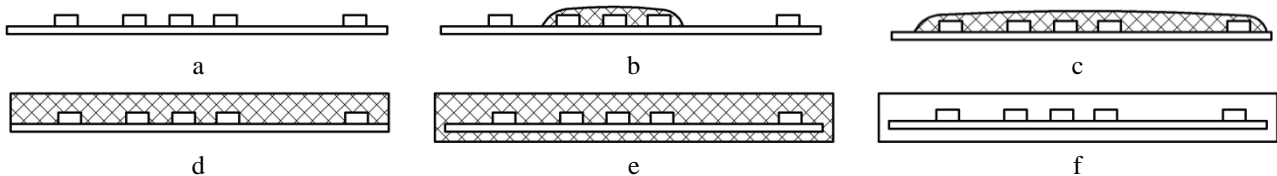

Fig. 1 Schematic presenting the major electronic module environmental protection: a) unsealed; b) partial substrate coating; c) complete substrate coating; d) partial encapsulation; e) complete encapsulation; f) sealed enclosure

or exploitation processes due to external impacts. On the other hand the main board substrate can have been produced warped before installing electronic components. The main board deformation or flattening warped one populated with components cause in them a strain, which at ultimate level entails breakages and units malfunction.

### 2. Mount stress in electronic components

Along with mentioned external factors the mount stress in electronic components caused by soldering technology has been considered. Strains produced by mount stresses can be summed up with environmental impacts. The main board interaction with electronic components through their pins and contact pads produce strain as in components or in contact joints, what demands particular study.

To experimentally verify this strain the 8-pin adapters were tested along with recording strain indicated by the strain gauge attached to the adapters' surface as shown in Fig. 2.

The experiments were conducted in the following sequence. First the strain gauge was attached to the adapter and then its pins were soldered to PCB. In the experiment the reference strain gauge indication was assumed when 8

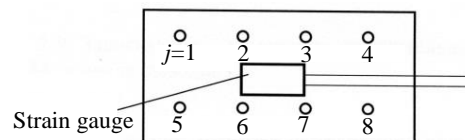

Fig. 2 8-pin adapter with the strain gauge attached ( $j=1\dots 8$ )

pins were firmly soldered. Then cutting pins off one by one the strain indications were recorded. Figure 3 demonstrates strain mean value changes at different number of pins soldered to PCB.

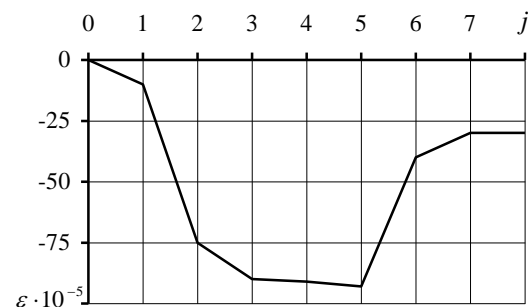

Fig. 3 Dependence between strain in adapter and number of its pins soldered to PCB

Fig. 3 indicates that mounting strain starts with increasing tendency as the number of soldered to PCB pins grows and then decreasing to strain  $\varepsilon = -27 \cdot 10^{-5}$  when all pins are mounted. This testifies that quantity of pins should be optimized to minimize mount stress effect on electronic components.

### 3. Strain effect of electronic component installation technologies

Horizontal installation of through-hole parts with two axial leads (Fig. 4, a) (such as resistors, capacitors, and diodes) is done by bending the leads 90 degrees in the same direction, inserting the part into the board (often bending leads are located on the back of the board in opposite directions to improve the mechanical strength of the part), soldering the leads, and trimming off the ends. In surface-mount technology, the component (Fig. 4, b) is placed on the PCB so that the pins line up with the conductive pads or lands on the surfaces of the PCB, the components are then soldered.

Analysis of the mentioned technologies testifies of multiple leads breakages. To prevent these breakages new high through-hole installation technology with raised lead bending has been developed (Fig. 4, c).

The effectiveness of the offered technology has been proven by experimental research of metal-film resistors OMLT-0.125 with strain gauges attached.

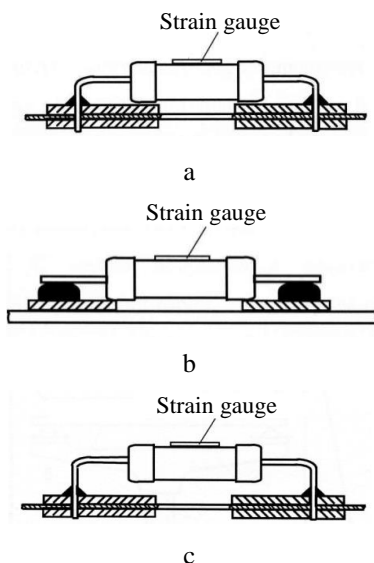

Fig. 4 Installation technologies of resistors on PCB

Resistors had been installed on PCB of the electronic module 21.5x17 mm which then was installed on the main board 350x75 mm.

To provide identical strain conditions to all resistors partaking in experiment the main board was subject to pure bending by the bending installation shown in Fig. 5.

The preliminary pure bending tests were conducted on PCBs under various loads. The tested PCBs had been prepared by attaching 10 mm base strain gauges in both longitudinal and lateral directions. The scatter of strain indications in all directions did not exceed 5%. During tests the lateral stains have not been detected.

The experimental research of resistors was conducted by the scheme shown in Fig. 6. The resistors were mounted on smaller PCBs, which in turn were mounted on

the main board. All resistors were divided into three groups corresponding to three installation technologies (Fig. 4): *S* – surface-mount installation; *L* – low through-hole installation; *H* – high through-hole installation. Each group was installed aligned with longitudinal axis of the main board. The strain conditions of all resistors were identical under pure bending test.

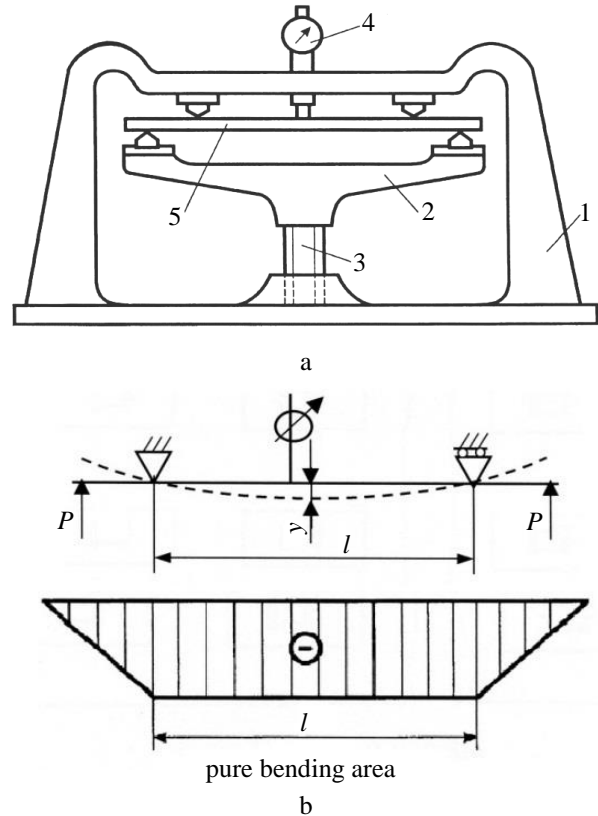

Fig. 5 Pure bending PCB: a – pure bending test installation: 1 – base; 2 – movable beam; 3 – screw gear; 4 – indicator; 5 – PCB; b – bending load scheme and bending moments diagram

The strain of external fibers in the main board is found from its maximal measured deflection  $f$  by the formula:

$$\varepsilon = \frac{4h}{l^2} f, \quad (1)$$

where  $h$  is thickness of PCB substrate.

The testing installation (Fig. 5) allows measuring deflection within 0-10 mm under the load up to 50 N. The strains generated in the main board are transmitted through leads onto PCBs of electronic modules and then to resistors through their leads. Since all tested resistors were put in the same strain conditions then the difference in strains detected is explained by difference in their installation technologies. Thus, the conclusion is made that the highest stain is received by resistors installed by surface-mount technology and the lowest – by resistors installed by the offered high through-hole installation technology. In case of surface-mount technology (Fig. 4, b) caps of resistors lay on the PCB and their leads are fastened by a solder layer. In general such composition is referred to the load scheme with clamped ends (solid installation), in which strain is transmitted through the leads and directly through the caps as well.

The high through-hole installation (Fig. 4, c) guarantees an elevation of the resistor cap above the PCB what makes complete covering leads with the solder highly unlikely. In this case the strain from PCB is transmitted rather to leads than to resistor (soft installation).

The low through-hole installation (Fig. 4, a) is considered as intermediate between solid and soft ones. The

level of strain transmitted from PCB to resistor gradually depends on amount of solder covering its leads.

Results of stress calculation in resistors installed by surface-mount technology ( $\sigma_R=9.8...17.4$  MPa) caused by main board bending deformation indicate 20 % level of the ultimate destructive stress ( $\sigma_U=95...165$  MPa).

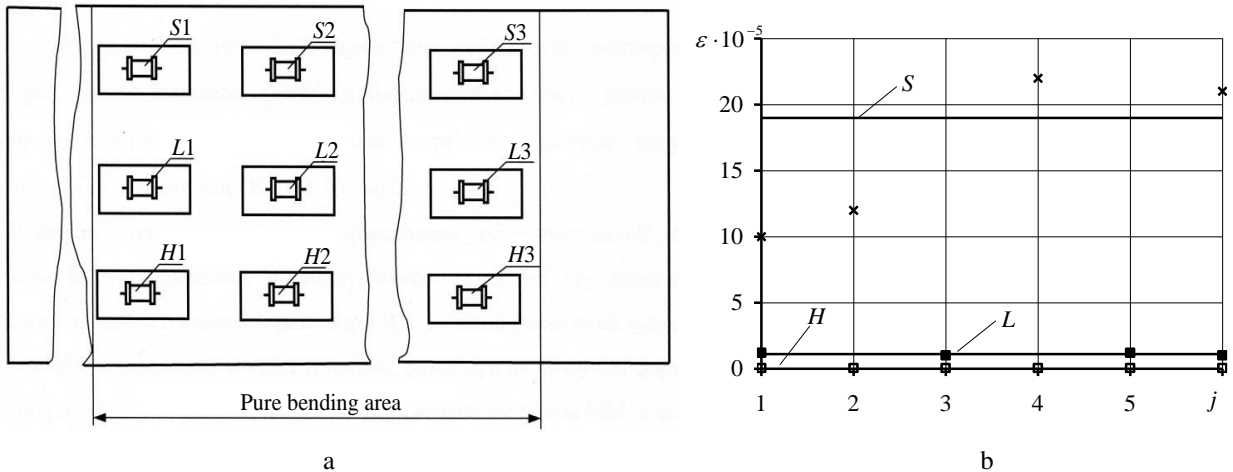

Fig. 6 Strain measurement of resistors, installed by three types installation technologies, under pure bending test: a – resistors layout on the main board; b – strain diagram markers: x – surface-mount installation (S); ■ – low through-hole installation (L); and their mean values (solid lines) at maximal main board deflection equal 8 mm

**4. Strain effect of integrated circuit installation technology**

To identify strain in integrated circuits caused by the main board deformation the experimental research was conducted by pure bending in the test installation shown in Fig. 5, a. For the experiment 17x9 mm ICs were installed on the 300x75 mm fiberglass main board substrate equally arranged from its central axis. There were tested two groups of ICs representing two different installation technologies.

The first technology is through-hole installation so that IC touches the PCB surface with no elevation and no gap in between them, the IC perimeter is then sealed with a compound (Fig. 7, a). Such installation can be called solid analogically to the objects described in the previous point. And again, solid installation, as well as for the resistors, had multiple breakages during operation.

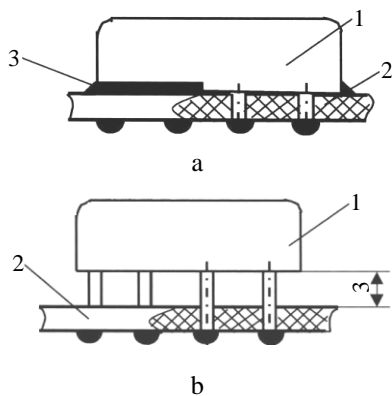

Fig. 7 IC through-hole installation technologies: a – solid: 1 – IC; 2 – PCB; 3 – sealant; b – soft

In case of the second through-hole installation technology, called soft, ICs were mounted to PCB with the gap  $\approx 2...3$  mm (Fig. 7, b).

The scheme of ICs layout on the PCBs in conducted experiment is shown in Fig. 8, a. The experiment was partaken by four ICs: two – mounted by solid installation technology (IC1) and another two – by soft one (IC2). All ICs were controlled by attached strain gauges as shown in Fig. 8, b.

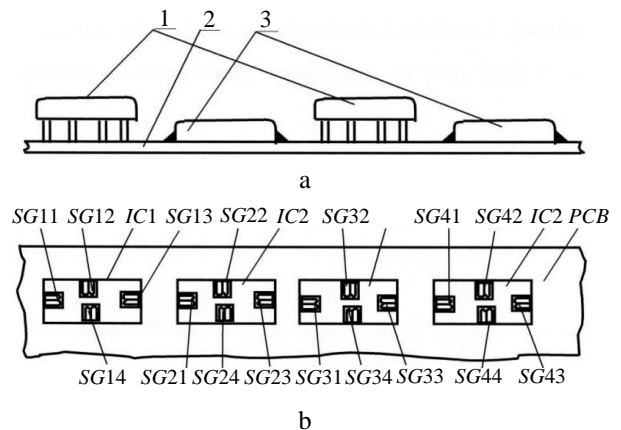

Fig. 8 Scheme of ICs layout on the PCB: a – front view: 1 – soft installation IC, 2 – solid installation IC, 3 – PCB, b – top view: SG – strain gauge, IC – integrated circuit, PCB – printed circuit board

The experiment resulted in three-four times higher strain level in ICs mounted by solid installation technology than in those mounted by soft installation technology (Fig. 9). This testifies that the strain in IC mounted on PCB depends on rigidity of their connection.

It is worth noting that in case of solid installation the rigidity of connection depends on elastic properties of both sealant [2] and leads, and in soft installation – on leads only. Thus, the study of effect produced by rigidity of pins on strain transmission from main board to IC attracts certain attention. Therefore strain transmission from the main board

to IC differing in their pins is planned for the further research.

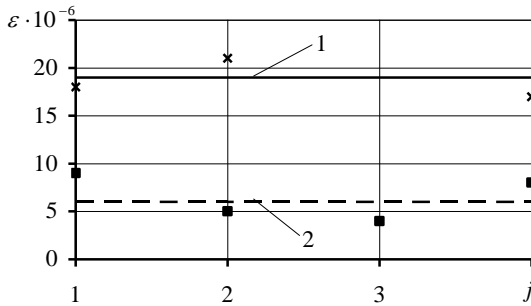

Fig. 9 Strain diagram markers: x – solid installation 1; ■ – soft installation 2; and their mean values (solid and dash lines correspondingly) at maximal main board deflection equal 8 mm

### 5. Influence of PCB load duration on strain in mounted electronic modules

The previous research has indicated that strain in electronic components depends on many factors: design, installation technology, quantity and rigidity of leads and pins etc. At the same time detected strains are characterized by significant scatter and instability in time what suggested an assumption about creep, relaxation which appear during operation.

In materials science, creep is the tendency of a solid material to move slowly or deform permanently under the influence of mechanical stresses. Relaxation is the process in which elastic deformations of a body transit to plastic ones.

In the present research the influence of time that the main board is under load on strain produced in sealed electronic modules is studied.

The experimental research was conducted in pure bending installation where the main board, populated with compound encapsulated and hollow electronic modules, remained under 8 mm center deflection during 22 hrs. The strain was measured on electronic modules during all experiment. After the first test the main board remained unloaded during 7 hrs, then experiment was repeated - this time for 21 hrs. The third experiment was conducted after board had been held unloaded during 24 hrs at normal temperature and another 4 hrs at 75 deg C in order to release the residual stress, the load was applied for 48 hrs.

Analysis of received data indicates that strain in electronic modules changes during the time the load is applied on the main board, what testifies of the present creep and relaxation processes running in the connection between the main board and electronic modules. These processes run more intensively in modules encapsulated with compound and after 20-40 hrs of testing the strain in encapsulated modules rise by 8-10 times.

However, at the end of the test the strains of not hollow modules significantly exceed those in the encapsulated. So at the beginning of the test the strains in the hollow modules make  $\varepsilon=(30\dots40)\cdot 10^{-5}$  and in encapsulated –  $\varepsilon=(1\dots4)\cdot 10^{-5}$ , then after they remain loaded during 32 hrs their strains make  $\varepsilon=(45\dots53)\cdot 10^{-5}$  and  $\varepsilon=(17\dots22)\cdot 10^{-5}$  correspondingly.

This process is caused not only by creep and relaxation of materials but also by the fact that at the beginning

when load is applied, the strain appears in that part of the pin, which is not filled with compound and its another part remains sealed in compound [3]. But since the compound is not absolutely rigid sealant it releases pins and eventually load is transmitted to the PCB of encapsulated module.

### 6. Strain in contact pads produced by main board bending

The main board substrate has very often been warped even before installing electronic components due to imperfect technologies. Once such board is installed into the housing of the electronic unit it is forced to be flattened what causes another deformation and strain in its contact pads.

To research these deformations the main board 300x80 mm was stuffed with 13.5x17.5 mm electronic modules having straight pins as shown in Fig. 10, b. Here is given the scheme of the strain gauges attachment to contact pads and adapter.

The strain gauges were attached to contact pads so that their pattern partly contacted the end of the pin and surface of the adapter (Fig. 10, b).

The strains obtained during pure bending test of the main board range from  $3.9\cdot 10^{-5}$  to  $135\cdot 10^{-5}$ . Fig. 10, a demonstrates dependences of average strain in contact pads on maximal deflection of the main board.

It is worth noting that strain gauges (41, 42) attached to the main board indicated  $\varepsilon=3.9\cdot 10^{-5}$  while gauges (33-40) attached to the contact pads indicated  $\varepsilon=28.8\cdot 10^{-5}$ . The obtained data shows that the strain in contact pads is 7-10 times higher than strain on the main board.

Thus, the deformation produced by the main board onto installed electronic components is found to be dependent on connecting leads or pins, and decreasing their rigidity or applying compensators can significantly reduce the influence of the main board on the electronic components. Strain in components installed by solid installation technology exceeds those by soft installation or with bent leads by 3-4 times at the same MB deformation. The level of strain in boards of EM depends on their design (encapsulated, open). For the short time as the main board starts to deform the encapsulated electronic module does not almost sustain any strain. The fact is that the level of strain in the boards of EM depends on duration of the load applied on the main board. The main strain in encapsulated EM depends on duration of the load and reaches the constant values after 30 hrs as earliest. Conducted experimental research has proven that the stress in contact pads can exceed stress in the main board significantly what makes them a weak link in the whole electronic package.

### 7. Acceptable limit specification method for PCB warpage

As mentioned before the main board substrate can be produced warped before installing electronic components. The main board deformation or flattening warped one populated with components cause them a strain, which at ultimate level entails breakages and units malfunction. Hence the limit of acceptable PCB warpage level needs to be specified.

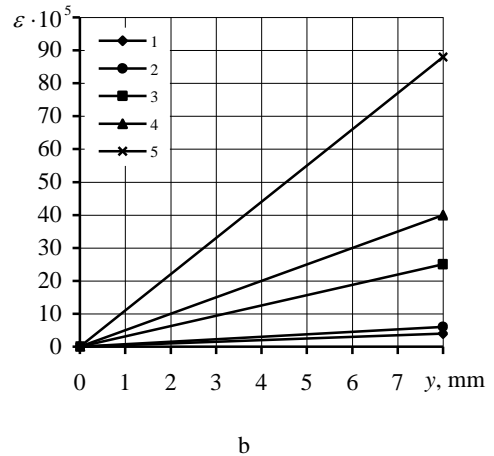
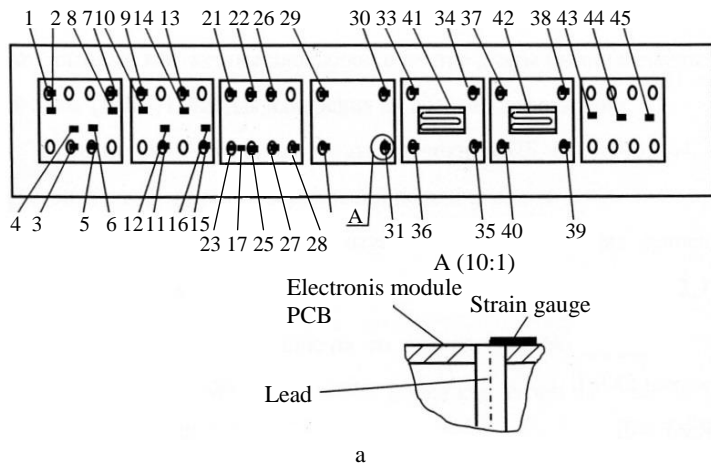

Fig. 10 Strain measurement of contact pads in EM installed on the main board: a – average strain to maximal deflection dependences: 1 – PCB; 2 – open boards with straight pins; 4 – encapsulated boards with straight pins; 3 – open boards with bent pins; 5 – encapsulated boards with bent pins; b – scheme of EM installation and attachment of the strain gauges

In accordance to the state industrial standard [4] the defects of PCB flatness are described as bow and twist. For the quality classes 1, 2, 3 the following issues are made to provide such acceptable limits for bow and twist: 0.75 % for surface-mount PCBs; 1.5 % for other types. However this standard does not consider the strain caused by multiple technological and environmental factors effecting boards and does not guaranty stable functioning of electronic modules installed on the boards.

In the present research the largest deformations caused by warpage in PCBs were found by using the following approaches: due to complexity of geometry warpage the strain in PCBs was experimentally measured by flattening the warped PCBs with an assumption that flattened board sustains the same strain as produced by this warpage but with opposite sign; the highest strain appears in the place with largest curvature.

For the research two types of main boards were taken, both types had been warped. The first type included 225×70×1.5 mm boards, the second – 140×30×1.5 mm.

The warpage is identified by elevation of a point on the warped board from the reference plane of the board considered flat; this elevation is called warpage height. This height reached 6 mm on the tested boards.

Strain gauges were attached to the first type boards as shown in Fig. 11.

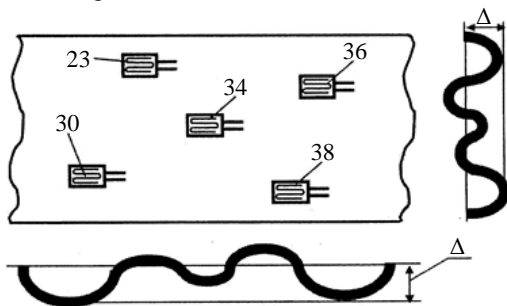

Fig. 11 Strain measurement on the warped board

The second type boards were characterized by twist warpage and strain gauges were attached as shown in Fig. 12. For some boards the twist angle reached 18.5°.

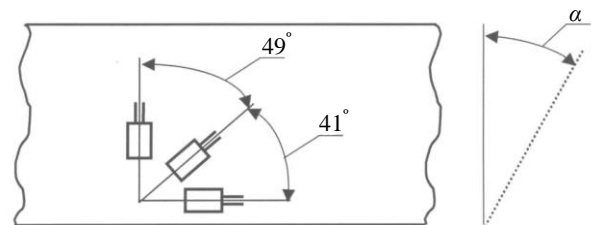

Fig. 12 Strain measurement on the warped board

The experiment was conducted so that main boards were flattened three times with strain recording.

The obtained data has proved an assumption that greater curvature causes higher strain, that in experiment reached the value of  $162 \times 10^{-5}$ .

The places of maximal deformation were purposed to install electronic modules for the further research. Modules were taken in different design.

The following conclusions made on the base of conducted experiments are:

1. Not encapsulated electronic modules are more sensitive to main board deformation.
2. The maximal strain in electronic modules, installed on a main board, appear in the places of its largest curvature.
3. The main board strain is inversely proportional to curvature radius of its surface.
4. The strain in electronic modules changes depending on deformation duration.
5. The period for electronic modules to reach stable deformation depends on the module design (hollow, partly encapsulated or completely encapsulated). It is maximal for completely encapsulated modules and makes 30–35 hrs.
6. The strain in electronic modules is directly proportional to main board strain in the place of module installation.

Acceptable limit specification method for PCB warpage was developed on the base of conducted experiments. The following operations are performed for each

module design irrespective to its installation technology on the PCB:

1. Test the electronic module, before installation on the main board, by most rigid external impact (thermal impact etc.) and measure strain in the weak links (contact pads, module PCB, some units) to specify largest strain.
2. Install module on the main board and test it again by pure bending applied to the main board to reach maximal strain detected in p. 1. Such board condition is assumed a reference one.
3. Increasing deflection of the main board in pure bending installation reach the module failure (condition in which module stops functioning). The strain equal to the difference of strains obtained in p. 2 and p. 3 is assumed the correspondent ultimate warpage  $\varepsilon_{ult}$ .
4. To provide proper functioning of electronic module specify warpage safety factor as ratio of ultimate warpage  $\varepsilon_{ult}$  to acceptable one  $[\varepsilon]$ :

$$n_s = \frac{\varepsilon_{ult}}{[\varepsilon]} \quad (2)$$

$n_s$  is to be continuously specified by analyzing technological factors, operational conditions and impacts effecting on the module in order to provide  $n_s > 1$ .

Described method is reliable to specify acceptable limit for PCB warpage for any design of electronic modules and any installation technology and involves extensive research work.

## 8. Conclusions

Optimization of electronic assembly pins quantity minimizes mount stress effect on electronic components.

Developed high through-hole installation technology of electronic components on the main board provides significant reducing of the strain transmitted to electronic components in comparison with standard low through-hole and surface-mount installation.

The strain in integrated circuits mounted on the main board depends on rigidity and design of their pins. The offered soft installation technology 3-4 times reduces strain in comparison with the solid installation.

Hollow electronic modules are more sensitive to main board deformation than the encapsulated ones. The strain in electronic modules changes depending on duration of the main board deformation they are installed on.

The deformation produced by the main board onto contact pads (assumed to be weak links of the whole structure) in electronic modules is found to be dependent on connecting leads or pins, and decreasing their rigidity or applying compensators can significantly reduce the influence of the main board onto the electronic components. The measured strain in case of soft installation technology is 3-4 times lower than the strain in solid installation.

The developed method for acceptable limit specification of PCB warpage is applicable for any design of electronic modules and any installation technology.

For the more detailed research of the strain in electronic components, which are relatively small objects, the further research will be aimed at application acoustic emission method in order to develop methods for strength diagnostics and predicting possible breakages at the stage long before a fatal destruction in electronic packages.

## References

1. **Mittal, K.L.; Pizzi, A.** 2009. Handbook of sealant technology. CRC Press: Taylor&Francis Group. Boca Raton. New York. 532 p.  
<http://dx.doi.org/10.1201/9781420008630>.
2. **Goroshko, A.V.; Royzman, V.P.; Bubulis, A.** 2013. Identification of physical and mechanical properties of compound by solving inverse problems. Vibroengineering Procedia International Conference "Vibroengineering – 2013". Vol. 1: 81-86.
3. **Royzman, V.; Petrashchuk, S.; Kovtun, I.; Lokoshchenko, A.** 2013. Calculation of mechanical stresses in adjoint system of electronic component and compound and strength assessment. Journal of Vibroengineering 15(1): 65-72.
4. State Industrial Standard GOST 53251-2014. 2014. Printed Circuit Boards. Classification of Defects.

I. Kovtun, J. Boiko, S. Petrashchuk, G. Baurienė, K. Pilkauskas

## EFFECTS OF THE STRAIN TRANSMISSION FROM THE MAIN BOARD TO THE INSTALLED ELECTRONIC COMPONENTS

### Summary

The paper presents research of mechanical strain in printed circuit board functional assemblies, which are parts of electronic packages in modern machines and mechanisms. The strain is caused by external impacts that occur in manufacturing and exploitation conditions. The paper studies effects of the strain transmission from the main board to the installed electronic components, such as integrated circuits, discrete components, adapters, sockets, connectors, electronic modules etc.: mount stress in electronic components; strain effect of electronic component installation technologies; strain effect of integrated circuit installation technology; the influence of the main board load duration on the strain in mounted electronic modules; the strain in contact pads produced by bending of the main board. Acceptable limit specification method for main board warpage is developed.

**Keywords:** strain, deformation, pure bending, warpage, main board, electronic component.

Received November 22, 2016  
Accepted December 02, 2016