

A reduction of the equations of the linear stationary vibrating systems without limitations of dissipation using the method of modal truncation

V. K. Augustaitis*, V. Gičan**, N. Šešok***, I. Iljin****

*Vilnius Gediminas Technical University, Basanaviciaus 28, 03224 Vilnius, Lithuania, E-mail: pgkatedra@vgtu.lt

**Vilnius Gediminas Technical University, Basanaviciaus 28, 03224 Vilnius, Lithuania, E-mail: pgkatedra@vgtu.lt

***Vilnius Gediminas Technical University, Basanaviciaus 28, 03224 Vilnius, Lithuania, E-mail: pgses@vgtu.lt

****Vilnius Gediminas Technical University, Basanaviciaus 28, 03224 Vilnius, Lithuania, E-mail: pgilj@vgtu.lt

crossref <http://dx.doi.org/10.5755/j01.mech.17.5.728>

1. Introduction

For computer-aided analytic research of complex vibrating systems with a large finite number of degrees of freedom, including linear stationary systems, various methods, for example, the method of finite elements and so on, are applied [1-5].

In the Paper, the mentioned linear vibrating systems are discussed upon. They are described by linear differential equations with constant coefficients. For digital integration of such equations, Runge-Kutta and other methods are applied. In a majority of cases, such systems have a very wide spectrum of natural frequencies; however, an investigator takes an interest in the much narrower range of the lowest natural frequencies within the said spectrum only. The high natural frequencies considerably increase the time of digital integration, so it is important to have a system of differential equations for describing the object under investigation where such frequencies are absent in the roots of its characteristic equations. Such equations can be obtained by reducing the number of degrees of freedom in the dynamical model of object under investigation. However, in many case, this task is difficult or even impossible. For example, such a problem appears when the method of finite elements is applied.

Other methods of elimination of high natural frequencies are obtained on the relevant reduction of the equations describing the vibrating system [6-14]. Among those methods, the method of modal truncation where the initial system of equations is divided to a number of independent equations is widely used; each of such independent equations describes modal vibrations of one natural frequency and then the equations corresponding to high natural frequencies are rejected (see, for example [10-14]). It is considered that the errors appearing in this case would be permissible, if the frequencies of the rejected modal vibrations are at least 1.5-2 times higher than the natural or resonance frequencies the investigator takes an interest in [15]. In some methods (see, for example, [16]), the errors of calculation appearing because of the rejected modal vibrations are counterbalanced by special components in the equations.

Although the known methods of modal truncation are effective, they are applicable only to vibrating systems with a proportional damping, when in the matrix equation describing the system, the elements of the damping matrix are proportional to the mass and stiffness matrixes or any of them. However, in many cases, damping cannot be considered proportional. This statement is applicable, for example, to complex mechatronical, mechanical and other

systems where modal truncation is important for their investigation.

The purpose of the paper: to propose a method for reduction of the equations used for describing linear stationary vibrating systems with any damping in state variables and reducing the time of digital integration. The method is based on formation of the equations of the system in state variables [17-19] using the normal Bulgakov's coordinates [20, 21] and application of modal truncation when the equations corresponding to high natural frequencies are eliminated (see below). The value of the error resulted by the truncation is assessed by comparing the frequency response of the vibrating system before and after the reduction in the frequency range under the interest of the investigator.

2. Initial version of the equations used for describing the system in state variables

Let's consider that such a nonreduced system of differential equations describing vibrations of the system (object) under investigation is formed

$$[A] \left\{ \ddot{q} \right\} + [B] \left\{ \dot{q} \right\} + [C] \{ q \} = \{ h(t) \} \quad (1)$$

where

$$\{ q \} = \{ q_1, q_2, \dots, q_n \}^T \quad (2)$$

the vector of the generalized coordinates q_i ($i = 1, 2, \dots, n$)

defining motions of the system; $\left\{ \dot{q} \right\} = \frac{d}{dt} \{ q \}$,

$\left\{ \ddot{q} \right\} = \frac{d^2}{dt^2} \{ q \}$; t is time or, more rarely, another argu-

ment; $[A]$, $[B]$, $[C]$ are square matrixes of the n -th degree with constant (stationary) elements; the – matrix $[A]$ may include $r \leq n$ zero lines and columns with the same serial numbers, i.e. in the system (1), r is differential equations of the first degree that include only those generalized coordinates q_j ($j = 1, 2, \dots, r$) and their fluxions \dot{q}_j not pre-

sented in the equation of the second fluxions \ddot{q}_j (Eq. (1)) can exist; $\{ h(t) \} = \{ h_1(t), h_2(t), \dots, h_n(t) \}^T$ is the vector of the n -th degree of external generalized forces involved in excitation of the system.

For examination of the vibrating system in state

variables, the Eq. (1) are reduced to the normal (Cauchy) form, i.e. when the generalized coordinates q_i are replaced for other variables, the system of equations is reduced to a system of differential equations of the first degree solved in respect of the first derivatives of the said variables. Such variables are considered phase or state variables of the system described by the Eq. (1) defining all states of the system in the time $t \geq t_0$ (t_0 is the initial time of observance of the system). For investigation of the said equations, special softwares are used [19, 21].

The most frequently applied method of introducing variables defining the states of a system under investigation is based on replacing the derivatives \dot{q}_k of the generalized coordinates q_k (with their derivatives of the second degree \ddot{q}_k included in the Eq. (1)) for new variables. It may be carried out as described in [21].

New variables are introduced

$$\begin{aligned} x_1 = q_1, x_2 = q_2, \dots, x_r = q_r, x_{r+1} = q_{r+1}, \dots, x_n = q_n, \\ x_{n+1} = \dot{q}_{r+1}, x_{n+2} = \dot{q}_{r+2}, \dots, x_{2n-r} = x_s = \dot{q}_n \end{aligned} \quad (3)$$

Their vector

$$\{x\} = \{x_1, x_2, \dots, x_r, x_{r+1}, \dots, x_n, x_{n+1}, \dots, x_s\}^T \quad (4)$$

To simplify the following description, it is considered that r equations having no second-degree derivatives of coordinates are in the beginning of the system (1), so the matrixes $[A]$ and $[B]$ can be divided into the following submatrixes.

$$[A] = \begin{bmatrix} O_{1,1} & O_{1,2} \\ O_{2,1} & A_{2,2} \end{bmatrix}; [B] = [B_1 \quad B_2] \quad (5)$$

where $[O]_{1,1}$, $[O]_{1,2}$, $[O]_{2,1}$ are zero matrixes of $r \times r$, $r \times (n-r)$, $(n-r) \times r$ degree; $[A]_{2,2}$ is nonsingular square matrix of the $(n-r)$ degree; $[B]_1$, $[B]_2$ are matrixes of the $n \times r$ or $n \times (n-r)$ degree.

Taking into account the Eqs. (3) and (5), we obtain the following instead of the system of Eq. (1)

$$\begin{aligned} \begin{bmatrix} O_{1,1} & O_{1,2} \\ O_{2,1} & A_{2,2} \end{bmatrix} \left\{ \ddot{q}_1, \ddot{q}_2, \dots, \ddot{q}_r, \dot{x}_{n+1}, \dot{x}_{n+2}, \dots, \dot{x}_s \right\}^T + \\ + [B_1 \quad B_2] \left\{ \dot{x}_1, \dot{x}_2, \dots, \dot{x}_r, x_{n+1}, x_{n+2}, \dots, x_s \right\}^T + \\ + [C] \{x_1, x_2, \dots, x_n\}^T = \{h(t)\} \end{aligned} \quad (6)$$

here the derivatives $\ddot{q}_1, \ddot{q}_2, \dots, \ddot{q}_r$ are specified only formally. They are multiplied by the zero submatrixes $[O]_{1,1}$ and $[O]_{2,1}$ of the matrix $[A]$, so really they are not presented in the equations (6). These zero submatrixes are replaced for the submatrix $[B]_1$, and the derivatives

$\ddot{q}_1, \ddot{q}_2, \dots, \ddot{q}_r$ are replaced for the derivatives $\dot{x}_1, \dot{x}_2, \dots, \dot{x}_r$. Then instead of the Eq. (6), we find

$$\begin{aligned} \begin{bmatrix} B_1 & O_{1,2} \\ & A_{2,2} \end{bmatrix} \left\{ \dot{x}_1, \dot{x}_2, \dots, \dot{x}_r, \dot{x}_{n+1}, \dot{x}_{n+2}, \dots, \dot{x}_s \right\}^T + \\ + [B]_2 \{x_{n+1}, x_{n+2}, \dots, x_s\}^T + \\ + [C] \{x_1, x_2, \dots, x_n\}^T = \{h(t)\} \end{aligned} \quad (7)$$

From it, we find

$$\begin{aligned} \left\{ \dot{x}_1, \dot{x}_2, \dots, \dot{x}_r, \dot{x}_{n+1}, \dot{x}_{n+2}, \dots, \dot{x}_s \right\}^T = \\ = -[G][B]_2 \{x_{n+1}, x_{n+2}, \dots, x_s\}^T - \\ - [G][C] \{x_1, x_2, \dots, x_n\}^T + [G] \{h(t)\} \end{aligned} \quad (8)$$

here the square matrix of the n th degree

$$[G] = \begin{bmatrix} B_1 & O_{1,2} \\ & A_{2,2} \end{bmatrix}^{-1} = \begin{bmatrix} G_1 \\ G_2 \end{bmatrix} \quad (9)$$

$[G]_1$, $[G]_2$ are the submatrixes where the lines are formed of r first lines and the remained $(n-r)$ lines of the matrix $[G]$. It is accepted that the inverse matrix is nonsingular and the Eq. (9) is valid. In such a case, the matrix $[A]_{2,2}$ as well as the matrix $[B]_{1,1}$, formed of r first lines of the matrix $[B]_1$ should be nonsingular.

In addition, the system of Eq. (8) does not include the equations defining the values of the fluxions $\dot{x}_{r+1}, \dot{x}_{r+2}, \dots, \dot{x}_n$. They are obtained from the part

$$x_{n+1} = \dot{q}_{r+1}, \dots, x_s = \dot{q}_n \text{ of the Eq. (3) taking into account}$$

that $\dot{q}_{r+1} = x_{r+1}, \dots, \dot{q}_n = x_n$. Then

$$x_{r+1} = x_{n+1}, x_{r+2} = x_{n+2}, \dots, x_n = x_{2n-r} = x_s \quad (10)$$

After uniting the Eqs. (8) and (10), we obtain the following normal equations describing the system under examination in its state variables instead of the Eq. (1)

$$\left\{ \dot{x} \right\} = [R] \{x\} + \{k(t)\} \quad (11)$$

where $\{x\}$ is the vector defined by the Eq. (4); its components are the coordinates describing the location of the system in its state variables

$$[R] = \begin{bmatrix} -G_1 C & -G_1 B_2 \\ O_2 & E_1 \\ -G_2 C & -G_2 B_2 \end{bmatrix} \quad (12)$$

The square matrix of $2n-r=s$ degree consists of: the zero submatrix $[O]_2$ of $(n-r) \times n$ degree and the unit submatrix $[E]_1$ of $(n-r)$ degree; the submatrixes $[G]_1$, $[C]$ and $[G]_1$, $[B]_2$ $r \times n$ of $r \times (n-r)$ degree; the submatrix $[G]_2[C]$ of $(n-r) \times n$ degree and the square submatrix $[G]_2[B]_2$ of $(n-r)$ degree

$$\{k(t)\} = [G]_* \{h(t)\} \quad (13)$$

The vector of $2n-r=s$ degree; $[G]_*$ is the matrix of $(2n-r) \times n = s \times n$ degree obtained from the matrix $[G]$ by inserting $(n-r)$ zero lines between its submatrixes $[G]_1$ and $[G]_2$.

On investigation of the vibrating system in its state variables, its output coordinates (output signals) y_e ($e=1,2,\dots,m$) (that describe the state of the object as well) bound with its variables $\{x\}$ by linear algebraic equations are added to its equation of state [18, 19]

$$\{y\} = [D]\{x\} + [H]\{h(t)\} \quad (14)$$

where $\{y\}$ is m dimensional vector ($m=1,2,\dots$); $[D]$, $[H]$ are matrixes of $m \times s$ and $m \times n$ degree with constant or varying in course of time elements; the values and character of variation of such elements depend on a system under investigation.

3. The proposed version of the equations of state variables and their reduction

The obtained mathematical model Eqs. (11) and (14) of the system under investigation in its state variables is based on the application of variables for defining the state of the system provided in the Eq. (4).

As it was mentioned above, on investigation of the vibrating systems described herein (Eq. (1)), it is not reads Eq. (11) because of a considerable time of integration, when the spectrum of natural frequencies of the system includes the range of high natural frequencies (out of the interests of the investigator), not only the range of low natural frequencies. It would be purposeful to reduce the Eq. (11) by eliminating components with high natural frequencies from their solutions and simultaneously maintaining an adequacy of the obtained results with a permissible error.

For such reduction of the Eq. (11) and saving the computer time, it is proposed in this paper to use the normal Bulgakov's coordinates for variables of the system's state of variables and the method of modal truncation on the base of [20, 21]. For this purpose, the below-described procedure is used.

The method is applicable, if the matrix $[R]$ has multiple natural values; in such a case, the element divisors related to them should be linear (this condition is equivalent to the condition on absence of any secular terms in the solutions of homogenous Eqs. (1) and (11), when $\{h\} \equiv 0$).

In addition, the vector $\left\{ \begin{matrix} \bullet \\ x \end{matrix} \right\}$ should have no zero compo-

nents, i.e. the systems of Eqs. (1) and (11) should include no algebraic equations. It is considered that the said conditions were satisfied (if secular members appear in solutions of the equations, they usually may be avoided by a slight correction of the dynamic model of the system under examination without losing its adequacy).

It is considered that the matrix included in the Eq. (11) has s natural values λ_j ($j=1,2,\dots,s$), including s' real natural values $\lambda_\sigma = \chi_\sigma$ ($\sigma=1,2,\dots,s'$) and s'' couples of complex conjugates roots $\lambda_{s'+h} = \varepsilon_h + i\omega_h$, $\lambda_{s'+s''+h} = \varepsilon_h - i\omega_h$; where ε_h , ω_h are real and imaginary parts of roots, $h=1,2,\dots,s''$, $i = \sqrt{-1}$.

The natural values λ_j of the matrix $[R]$ are also the roots of the characteristic equations of the systems of Eqs. (1) and (11), the values ω_h is the natural frequencies of the system under investigation; ε_h is defines damping of free vibrations with frequency ω_h and χ_σ defines aperiodical nonvibrating processes. It can be seen that $s = s' + 2s'' = 2n - r$.

Each real natural value λ_σ of the matrix $[R]$ corresponds to its own vector $\{V\}_\sigma = \{v\}_\sigma$ with s components, each complex couple of roots $\lambda_{s'+h}$ and $\lambda_{s'+s''+h}$ - to own vectors $\{V\}_{s'+h} = \{v\}_{s'+h} + i\{v\}_{s'+s''+h}$ with s components and, correspondingly, $\{V\}_{s'+s''+h} = \{v\}_{s'+h} - i\{v\}_{s'+s''+h}$. The natural values $\lambda_{s'+s''+h}$ and the own vectors $\{V\}_{s'+s''+h}$ corresponding to them hereinafter will not be used.

Each natural vector $\{V\}_{s'+h}$ is simultaneously the mode of natural vibrations corresponding to the natural frequency ω_h of the homogenous part of the system under investigation Eq. (1) according to the generalized coordinates q_1, q_2, \dots, q_n and the mode of speeds of natural vibrations according to the derivatives of the generalized coordinates $\dot{q}_{r+1}, \dot{q}_{r+2}, \dots, \dot{q}_n$. The complex form of these vectors shows that they were formed taking into account the damping in the system; however, no special requirements are set for the character of the latter [20, 21]. Each natural vector $\{V\}_\sigma$ is simultaneously the mode of aperiodic motions corresponding to the real root λ_σ of the homogenous part of the system under investigation (1) according to the generalized coordinates q_1, q_2, \dots, q_n and their derivatives $\dot{q}_{r+1}, \dot{q}_{r+2}, \dots, \dot{q}_n$.

When the natural vectors are known, a square modal matrix of the s -th degree $[v]$ consisting of s' columns of the vectors $\{v\}_\sigma$ and $2s''$ columns of the real $\{v\}_{s'+h}$ and imaginary $\{v\}_{s'+s''+h}$ parts of the vectors $\{V\}_{s'+h}$ is formed [15]. When the said columns are laid out in the way where s' first columns of the matrix $[v]$

are the vectors $\{\nu\}_\sigma$ and then couples of the vectors $\{\nu\}_{s+h}$ and $\{\nu\}_{s+s''+h}$ follow, the following structure of

$$[\nu] = \begin{bmatrix} \nu_{1,1} \cdots \nu_{1,s'} & \nu_{1,s'+1} & \nu_{1,s'+s''+1} & \nu_{1,s'+2} & \nu_{1,s'+s''+2} & \cdots & \nu_{1,s'+s''} & \nu_{1,s} \\ \nu_{2,1} \cdots \nu_{2,s'} & \nu_{2,s'+1} & \nu_{2,s'+s''+1} & \nu_{2,s'+2} & \nu_{2,s'+s''+2} & \cdots & \nu_{2,s'+s''} & \nu_{2,s} \\ \dots & \dots & \dots & \dots & \dots & \dots & \dots & \dots \\ \nu_{s,1} \cdots \nu_{s,s'} & \nu_{s,s'+1} & \nu_{s,s'+s''+1} & \nu_{s,s'+2} & \nu_{s,s'+s''+2} & \cdots & \nu_{s,s'+s''} & \nu_{s,s} \end{bmatrix} \quad (15)$$

Considering that the matrix $[R]$ satisfies the above-mentioned conditions, a replacement of the variables of the system (11) is carried out [20, 21]

$$\{x\} = [\nu]\{\xi\} \quad (16)$$

where

$$\{\xi\} = \left\{ \xi_1, \dots, \xi_\sigma, \dots, \xi_s, \xi_{s'+1}, \xi_{s'+s''+1}, \dots, \xi_{s'+h}, \xi_{s'+s''+h}, \dots, \xi_{s'+s''}, \xi_s \right\}^T \quad (17)$$

is the vector of s th degree in the normal Bulgakov's coordinates (NBC).

After inserting the value Eq. (16) of the vector $\{x\}$ into the Eq. (11), we find [15]

$$\left\{ \dot{\xi} \right\} = [Q]\{\xi\} + [z]\{h(t)\} \quad (18)$$

where, if the order of components of the vector $\{\xi\}$ provided in the Eq. (17) is preserved

$$[Q] = [\nu]^{-1}[R][\nu] = \begin{bmatrix} \chi & O_3 \\ O_4 & \Omega \end{bmatrix} \quad (19)$$

$[O]_3, [O]_4$ are zero submatrixes of the $s' \times 2s''$ and $2s'' \times s'$ degree;

$$[\chi] = \text{diag} \{ \chi_1, \dots, \chi_s \} \quad (20)$$

$[\Omega]$ is the block square submatrix of the $2s''$ degree; square submatrixes

$$\begin{bmatrix} \varepsilon_h & \omega_h \\ -\omega_h & \varepsilon_h \end{bmatrix}, \quad h=1,2,\dots,s'' \quad (21)$$

are situated along its diagonal and all remained elements of the said submatrix are zero elements;

$$[z] = [\nu]^{-1}[G]^* \quad (22)$$

matrix of the $(2n-r) \times n = s \times n$ degree.

The scalar expression of the Eq. (18) will be as follows. To each real root χ_σ , an equation not bound with other equations

this matrix is obtained [20, 21]

$$\dot{\xi}_\sigma - \chi_\sigma \xi_\sigma = \Phi_\sigma(t), \quad (\sigma=1,2,\dots,s') \quad (23)$$

will correspond, and to each complex joint root $\varepsilon_h \pm i\omega_h$, a couple of equations not bound with other equations

$$\begin{cases} \dot{\xi}_{s+h} - \varepsilon_h \xi_{s+h} - \omega_h \xi_{s'+s''+h} = \Phi_{s+h}(t); \\ \dot{\xi}_{s'+s''+h} + \omega_h \xi_{s+h} - \varepsilon_h \xi_{s'+s''+h} = \Phi_{s'+s''+h}(t); \quad (h=1,2,\dots,s') \end{cases} \quad (24)$$

will correspond, where

$$\begin{aligned} \Phi_\sigma &= \sum_{k=1}^n z_{\sigma,k} h_k & \Phi_{s'+h} &= \sum_{k=1}^n z_{s'+h,k} h_k; \\ \Phi_{s'+s''+h} &= \sum_{k=1}^n z_{s'+s''+h,k} h_k \end{aligned} \quad (25)$$

So, the initial system of equations was divided to independent equations with easily findable solutions. The variables $\{x\}$ as well as the coordinates $\{q\}$, if the normal Bulgakov's coordinates $\{\xi\}$ are known, should be found from the Eq. (16). It should be noted that the division of the equations of the system under investigation into independent equations was carried out without applying any limitations to the structure and elements of the matrix $[B]$ included in an equation of the system (1).

The other version of equations of the system under investigation in the state variables consists of the system of Eq. (18) with the joined system of algebraic linear Eq. (14) where the value of the vector $\{x\}$ is taken from the Eq. (16)

$$\{y\} = [D][\nu]\{\xi\} + [H]\{h(t)\} \quad (26)$$

This version differs from the above-mentioned one (see the Eqs. (11) and (14)) in a considerably simpler structure of the differential equations; in addition, it provides an opportunity of a major reduction of these equations using the method of modal truncation.

It may be made sure that upon investigating of a dynamical system in its state variables and solving the equations that describe it by numerical integration, the process of the integration will be longer when the natural frequencies of the system are higher and processes of higher frequencies are explored (the step of integration becomes smaller). If the range of natural frequencies of the system under investigation is very large and the investigator takes an interest in the range of low frequencies only, the process of integration can be shortened considerably by eliminating the systems of Eqs. (24) that correspond to

higher natural frequencies ω_h from the process of calculation, i.e. by applying the method of modal truncation. In addition, often all Eq. (23) or a part of them can be neglected. In such a case, instead on the matrix (19) and the system of Eq. (18), we obtain

$$[Q]_* = \begin{bmatrix} \chi_* & O_5 \\ O_6 & \Omega_* \end{bmatrix} \quad (27)$$

$$\left\{ \dot{\xi} \right\}_* = [Q]_* \{ \xi \}_* + [z]_* \{ h(t) \} \quad (28)$$

where $\{ \xi \}_*$ is the vector obtained from the vector $\{ \xi \}$ after elimination of the neglected NBCs; $[\chi]_*$; $[\Omega]_*$ are

square submatrixes of the α and 2β degree obtained from the submatrixes (19) and (20) when a part of the Eqs. (23) and a part of the couples of Eqs. (24) are neglected; $\alpha < s'$, $\beta < s''$ – the number of the remained Eqs. (23) and, correspondingly, the remained couples of Eqs. (24); $[O]_5$, $[O]_6$ are zero submatrixes; $[Q]_*$ is the square matrix of $(\alpha + 2\beta)$ degree analogous to the matrix $[Q]$, but without the excluded elements of the Eqs. (23) and (24); $[z]_*$ is the matrix of $(\alpha + 2\beta) \times n$ degree obtained from the matrix $[z]$ after elimination of the lines with the serial numbers corresponding to the eliminated coordinates ξ_σ , $\xi_{s'+h}$, $\xi_{s'+s''+h}$.

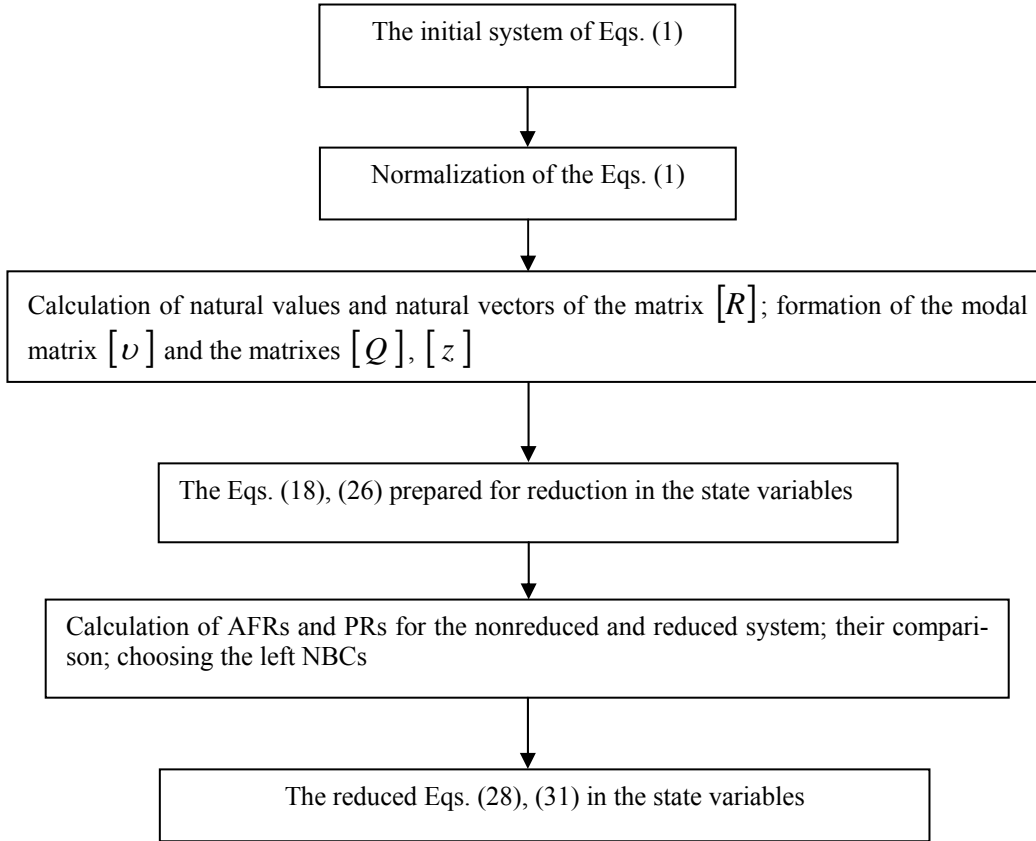

Fig. 1 The scheme of formation of reduced equations of a vibrating system in state variables

The approximate values of the variables x_p , i.e. x'_p ($p=1, 2, \dots, s$), are found from the equation that is analogous to the Eq. (16)

$$\{ x' \} = [v]_* \{ \xi \}_* \quad (29)$$

where $\{ x' \}$ is the vector of the approximate variables x'_p of the state variables, $[v]_*$ is the reduced modal matrix of $s \times (\alpha + 2\beta)$ degree found from the matrix $[v]$ where only the columns corresponding to the assessed natural values λ_j of the matrix $[R]$ are left.

The v – dimensional vector $\{ y' \}$ of approximate coordinates of the output of the system is found from the

equation that is analogous to the Eq. (14)

$$\{ y' \} = [D]_* \{ x' \} + [H] \{ h(t) \} \quad (30)$$

After insertion of the value of the vector $\{ x' \}$ from Eq. (29) into the equation, we find

$$\{ y' \} = [D]_* [v]_* \{ \xi \}_* + [H] \{ h(t) \} \quad (31)$$

So, the reduced version of the equations of the system under investigation with NBCs in the state variables consists of the systems of Eqs. (28) and (31).

The issue of the numbers α and 2β remained in NBC ξ_j is important. In a majority of cases, a reduction of the number α of the Eqs. (23) can be avoided and only

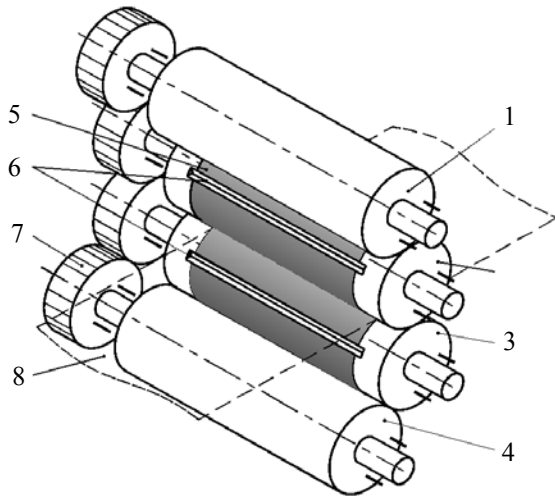

Fig. 2 The scheme of the dynamic al model of the example

the number β of the Eqs. (24) can be reduced; however, a specific decision should be passed for each individual system under investigation. For defining the number of the remained NBC, it is proposed to compare the amplitude-frequency responses (AFRs) and the phase responses (PRs) obtained upon certain selection of the components of the vector $\{h(t)\}$ for the non-reduced system (1) or (11), (18) with the respective responses of the reduced system (28) calculated in the range of frequencies the investigator is interested in. Nonzero components of the vector $\{h(t)\}$ can be following

$$h_a(t) = A_a \sin \nu t + B_a \cos \nu t \quad (32)$$

$$(a = 1, 2, \dots, n)$$

here the values of the constant the coefficients A_a , B_a and the range $\Delta \nu$ of changing of the excitation frequencies ν are chosen by the investigator. Upon comparison of AFRs and PRs of the whole and reduced systems, the value of inadequacy is a base for making a conclusion on the level of the errors of the reduction and the required number of remained NBC. One of the possible algorithms for AFRs and PRs calculation that does not require much time for the calculation is provided in [15]. The algorithm is based on the application of solutions of the equations (18) in the analytic form and the equation (16) in the case of harmonic excitation of the system. The scheme of formation of the reduced equations in Bulgakov's coordinates is shown in Fig. 1.

4. Example

In our paper [22], a system of equations of the type Eq. (18) for investigating transversal vibrations of the unit of plate cylinders and blanket cylinders in a section of offset printing press was described and used. Using the results of the said work, we'll show an efficiency of the proposed reduction. The above-mentioned unit (Fig. 2) consists of two plate cylinders 1, 2 with printing forms attached to them (Fig. 2, not shown herein) and two blanket cylinders 3, 4 covered by a special elastic textile (blanket) 5. The blankets are fixed to the said cylinders by special oblong locks along the generatrices of the cylinders.

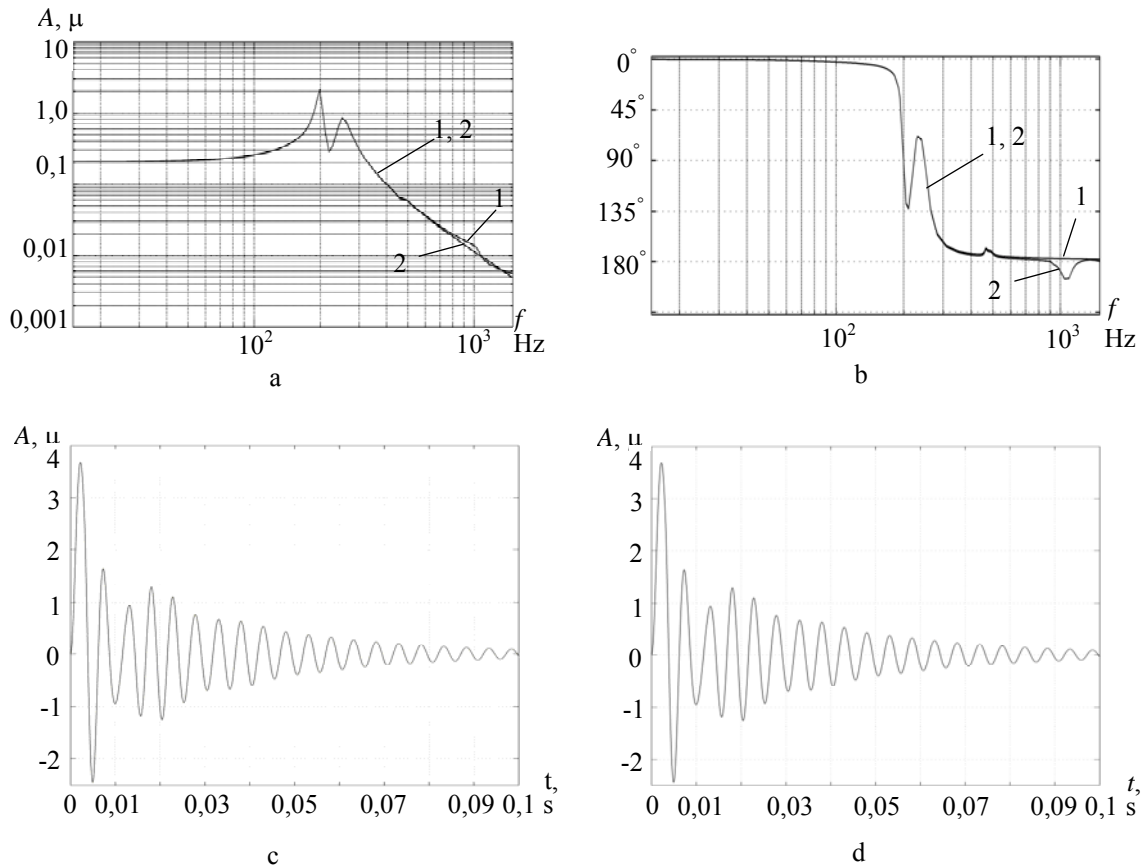

Fig. 3 Transverse vibrations of the middle of the blanket cylinder of the model: a, b – the amplitude and phase responses versus frequency (1 – for the whole system, 2 – for the simplified system); c, d – vibrations caused by shocks of the blanket fixing locks for the whole system (c) and the simplified system (d)

The length of all cylinders is 1040 mm, the diameter - $\varnothing 200$ mm. The printing process runs as follows: while the cylinders connected with gearwheels 7 and pressed against each other along their generatrices rotate and deform the blanket, the prints from the ink-moistened printing forms are transferred to the blankets 5 and from them – to the both sides of the paper tape 8 moving between the blanket cylinders 3, 4. The position of the blanket cylinders 3, 4 pressed against each other through the blanket 5 is regulated in such a way that ensures getting of the locks 6 into collision while rotation of the cylinders. It causes blows and transversal vibrations of the cylinders pressed against each other (similar vibrations appear on getting of the locks into collision with surfaces of plate cylinders; however, the intensity of such vibrations is lower). For description of the vibrations, the equations of the type (1), then also the equations of the types (11), (18) are used; in [17], these equations are further used nonreduced. For formation of the equations, all cylinders are divided into finite elements. In addition, elasticity and damping of the blankets 5 as well as deformation of the bearing units of cylinders are taken into account. Thus, a system with 168 degrees of freedom is formed. Its natural frequencies are situated in the 171.5 - 530183 Hz range. Blows are simulated by rectangular 100 N force impulses with duration of 0.003 s (the period 0,1 s); the said impulses impact the pressed against each other plate cylinders in the radial direction in units of finite elements entering into contact in the zones of the plate cylinders (each of two plate cylinders is impacted by 10 impulses). The transversal vibrations generated by the said impulses in the middle of the plate cylinder 2 are calculated.

It is accepted that a person engaged in the calculation takes an interest in vibrations with the frequencies up to 700 Hz, so only 12 couples of equations in normal Bulgakov's coordinates are left in the reduced system.

They correspond to all natural frequencies of the system up to 750 Hz.

Amplitude-frequency and phase responses of the complete and the reduced system are calculated for the range 0-1000 Hz, where the force impulses are replaced by harmonic excitation. The calculations were carried out using the mathematical simulation set MATLAB. When the equation (11) is applied for the calculations, the time of numerical integration equals to 14 min 14 s (the step 5e-7), and when the reduced equation of the type (30) is applied, it equals to 8 s (the step 1e-5), i.e. the time reduces 106 times. The conversion of the system (11) into equations of the type (18) took 1.5 s, and the calculation of the frequency responses took 2 s.

The obtained results are shown in the Fig. 3. It can be seen that the error of the reduction in the range 0-750 Hz is very small.

5. Conclusions

1. For shortening the time of numerical integration of the differential equations usable for describing linear stationary vibrating systems with a wide spectrum of their natural frequencies, it is purposeful to convert the said equations in to the normal Bulgakov's coordinates and then to reduce them eliminating the equations to high natural frequencies by the method of modal truncation.

2. For the proposed method of calculation, no

limitations for dissipation of the vibrating system are required.

3. The value of the error appeared during the reduction is assessed by a comparison of the amplitude-frequency and phase responses of the system under investigation obtained from the initial and reduced equations with harmonic excitation.

References

1. **Ragulskis, K.; Dabkevičius, A.; Kibirškštis, E.; Bivainis, V.; Miliūnas, V.; Ragulskis, L.** 2009. Investigation of vibrations of a multilayered polymeric film, *Mechanika* 6(80): 30-36.
2. **Jonušas, R.; Juzėnas, E.; Juzėnas, K.** 2010. Analysis of some extreme situations in exploitation of complex rotary systems, *Mechanika* 1(81): 53-57.
3. **Lučinskis, R.; Mažeika, D.; Hemsel, T.; Bansevicius, R.** 2010. The experimental research of piezoelectrical actuator with two vectors of polarization direction, *Mechanika* 2(82): 50-57.
4. **Eun-Taik Lee, Hee-Chang Eun, Tae-Wan Kim.** 2011. Damage detection of truss structure based on the variation in axial stress and strain energy predicted from incomplete measurements, *Journal of Vibroengineering*, vol. 13, issue 2: 173-185.
5. **Lučinskis, R.; Mažeika, D.; Daukševičius R.** 2011. Rod shaped piezoelectric actuator with radial polarization, *Journal of Vibroengineering*, vol. 13, issue 2: 358-364.
6. **Hatch, M.R.** 2001. *Vibration simulation using MATLAB and ANSYS*, Chapman and Hall/CRC. London – New York. 656 p.
7. **MATLAB.** Robust Control Toolbox. Function. Model Order Reductions.
8. **Documentation for ANSYS.** Analysis Tools (Damping Matrices; Mode Superposition Method; Reduced Order Modeling of Coupled Domains).
9. **Guyan, R.J.** 1965. Reduction of stiffness and mass matrices, *Amer. Inst. Aeronaut. Astronaut. Journal* 3(2): 380.
10. **Zou, Ch. P.; Hua, H. X.; Chen, D. S.** 2002. Modal synthesis method of lateral vibration analysis for rotor-bearing system, *Computer and Structures*. 80: 2537-2549.
11. **Galvini, P.; Vivio, F.** 2007. Dynamic reduction strategies to extend modal analysis approach at higher frequencies, *Finite Elements in Analysis and Design* 43: 931-940.
12. **Papagiannopoulos, G. A.; Beskos, D. E.** 2010. Towards a seismic design method for plane steel frames using equivalent modal damping ratios, *Soil Dynamics and Earthquake Engineering* 30: 1106-1118.
13. **Besset, S.; Jezequel, L.** 2009. Optimization of characteristics of porous materials based on a modal synthesis method, *European Journal of Mechanics A/Solids* 28: 102-109.
14. **Safonov, M. G.; Chiang, R. Y.; Limerbeer, D. J. N.** 1990. Optimal hankel model reduction for nominal systems, *IEEE Trans. on Automat. Contr.* vol.35, 4: 496-502.
15. **Rubin, S.** 1975. Improved component-mode representation for structural dynamic analysis, *AIAA Journal*. vol. 13, Nr. 8: 995-1006.

16. **Grigor'yev, V.G.** 1988. On the computing aspects of using the correcting series in synthesis of substructures according to the method of free limits, *Vestnik MGTU. Series Machine Building*, 4: 17-27 (in Russian).
17. **Dorf, R.C.; Bishop, R.H.** 2000. *Modern Control Systems*. 9 edition. Addison-Wesley. 820 p.
18. **Derusso, P.M.; Roy, R.J.; Close, Ch.M.** 1965. *State Variables for Engineers*. John Wiley and Sons, INC. New-York – London – Sydney. 620 p.
19. *Automatic Control Theory. Reference Book*. 1987. Edited by **Krasovsky, A.A.** Moscow: Nauka, 712p. (in Russian).
20. **Bulgakov, B.V.** 1954. *Vibrations*, Moscow: Gostekhizdat. 891p. (in Russian).
21. **Augustaitis, V.K.** 1994. *Analysis and Synthesis of Vibrations within the Machines as Applied to Drive Units of Machine Tools*, Vilnius: Technika. 307p. (in Russian).
22. **Augustaitis, V.K.; Šešok N.** 2004. Relative transversal vibrations of printing – press cylinders that are pressed against each other via an elastic blanket, *Strojniški Vestnik. Journal of Mechanical Engineering*, vol. 50, 5: 277-290.

V.-K. Augustaitis, V. Gičan, N. Šešok, I. Iljin

NETURINČIŲ DISIPACIJOS APRIBOJIMŲ TIESINIŲ STACIONARIŲJŲ VIRPAMŲJŲ SISTEMŲ LYGČIŲ PRASTINIMAS MODALINĖS ATKIRTOS BŪDU

Re z i u m ė

Siūdomas tiesines stacionariąsias virpamąsias sistemas su baigtiniu laisvės laipsnių skaičiumi aprašančių diferencialinių lygčių supaprastinimo metodas šių lygčių skaitmeninio integravimo laiko sumažinimo tikslu, kai virpamosios sistemos dinaminis modelis turi platų savųjų dažnių spektrą, o tyrėją domina tik jame esantis žemų savųjų dažnių intervalas. Tuo tikslu lygtys sudaromos sistemos būsenų erdvėje taikant normalines Bulgakovo koordinates ir po to modalinės atkirtos būdu atmetant aukštiesiems saviesiems dažniams atitinkančias lygtis. Metodas nereikalauja nagrinėjamųjų sistemų slopinimo apribojimų. Pavyzdyje parodyta, kad tiriant 168 laisvės laipsnių sistemą skaitmeninio integravimo trukmė po supaprastinamo sutrumpėja apie 100 kartų esant mažoms supaprastinamo paklaidoms.

V.-K. Augustaitis, V. Gičan, N. Šešok, I. Iljin

A REDUCTION OF THE EQUATIONS OF THE LINEAR STATIONARY VIBRATING SYSTEMS WITHOUT LIMITATIONS OF DISSIPATION USING THE METHOD OF MODAL TRUNCATION

S u m m a r y

A method for reduction of differential equations describing linear stationary vibrating systems with a finite number of degrees of freedom usable for shortening the time of digital integration of such equations, when the dynamic model of the vibrating system has a wide spectrum of natural frequencies and the investigator takes an interest in the range of low natural frequencies within the said spectrum only, is proposed herein. For this purpose, the equations are formed in the state variables of the system using the normal Bulgakov's coordinates and then are reduced by rejecting the equations bound with higher natural frequencies according to the method of modal truncation. The method does not require any limitations of damping of the systems under the investigation. In the example, it is shown that in case of a system of 168 degrees of freedom, the time of digital integration was reduced after simplification about 100 times upon small reduction errors.

Received February 11, 2011

Accepted August 30, 2011