

# Multi-valve intake port parametric design and performance optimization of the horizontal diesel engine

He Changming\*, Xu Sichuan\*\*, Zuo Chaofeng\*\*\*, Chen Xin\*\*\*\*, Li Chuanyou\*\*\*\*\*

\*Tongji University, Shanghai, China, E-mail: xiaominggoo@163.com

\*\*Tongji University, Shanghai, China, E-mail: scxu@tongji.edu.cn

\*\*\*Goptima, Shanghai, China, E-mail: jzuo@goptima.com

\*\*\*\*Goptima, Shanghai, China, E-mail: echen@goptima.com

\*\*\*\*\*Goptima, Shanghai, China, E-mail: mli@goptima.com

crossref <http://dx.doi.org/10.5755/j01.mech.17.6.1008>

## 1. Introduction

The combustion process of diesel engine directly affects the whole power output, fuel consumption and emissions level. The in-cylinder air motion, mixture formation and combustion process is closely related with the intake and exhaust ports, valves and combustion chamber shape [1, 2]. The in-cylinder turbulence and eddy motion also depend upon the intake port geometry and combustion chamber profile [3, 4]. Therefore, the trapped mass during the intake stroke is an important index that measures the entire engine performance. Besides the challenge of increasingly stringent emissions regulations, modern low-emission diesel engine designers still keep high thermal efficiency of engine as a goal. However, the key is how to achieve exact match of the high-pressure fuel injection and in-cylinder swirl intensity. As fuel injector is porous and injection pressure higher, a relatively lower swirl level enough to make the fuel spray mix well with air charge. This shows that the in-depth study of the relationship between intake port geometry and its performance is significantly crucial.

For current researches, the inlet design mainly focus on taking the existing inlet port as the initial model, CAD model is usually derived by 3D coordinate scanner based on reverse engineering method, then followed by amendments and improvements for intake ports [5-8]. The limitations of this approach are that the parametric relationship of inlet model curves and its surfaces is inexistence, and just only the local structure area can be adjusted, so that it restricts the design and development of innovative inlet port types, especially restraining the application and evolution of the multivalve technology on the traditional engine. But present research in this area is relatively rare and most of them are confined to reverse engineering design, meanwhile lack of more experimental verifications.

In this paper, a new advanced design method is adopted to build up a dual inlet port physical model. The sensitive areas which affect the helical port performance are calibrated by the in-cylinder flow field analysis and steady-state flow test, and finally three ports with different structural parameters are made into cylinder head products, the steady-state flow test during the intake process is completed on the test bench.

## 2. Advanced design method of multivalve intake port

### 2.1. Spiral curve equation for helical intake port

The UG software is selected as the modeling tool,

the establishment of helical port model needs to build a series of controlled trajectory curves as the basic conditions, and then create the joint surfaces. First of all, it is to determine the geometry shape at port entrance and the relative position at the cylinder head side, and the position that valve center line is relative to the cylinder liner axis, and then helical intake port is divided into two parts to deal with, i.e. the helical segment and direct flow section for flow orientation. Controlled trajectory curves of helical segment are structured by applying the Logarithmic spiral and Archimedean spiral equations. The above spiral formulas are all converted into codes which UG software can identify.

The Logarithmic spiral equation is

$$\begin{cases} x(t) = \exp(a_1 \text{rad}(A_1 t)) \cos(A_1 t) + d_1 \\ y(t) = \exp(a_1 \text{rad}(A_1 t)) \sin(A_1 t) + d_2 \end{cases} \quad (1)$$

The Archimedes spiral equation is

$$\begin{cases} x(t) = a_2 \text{rad}(A_2 t) \cos(A_2 t) + d_3 \\ y(t) = a_2 \text{rad}(A_2 t) \sin(A_2 t) + d_4 \end{cases} \quad (2)$$

where  $t$  is the default variant of the system;  $a_1, a_2$  are the amplification factor of the curves;  $A_1, A_2$  are the rotation angles,  $d_1, d_2, d_3$  and  $d_4$  are the offsets relative to the coordinate system.

The following general formula depicts the spiral curves variation trend along the Z axis

$$z(t) = a_0 (t + k)^s + d_0 \quad (3)$$

where  $a_0, k, d_0$  are constant coefficients for this equation and  $s$  is the index.

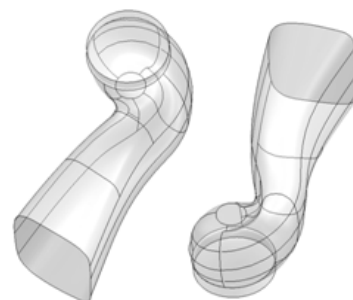

Fig. 1 The overall curve framework of helical intake port

The bridge characteristics and association properties are applied to construct direct flow segment of intake port for the better transition between helical segment and the inlet entrance. The overall framework for the space curves is just shown in Fig. 1. In the initial phase of the design, it needs to consider the spatial layout influence of the parting lines on core box production, thus to facilitate sand mould demolding.

## 2.2. The establishment of the cross-section curve equation

The cross-section shapes, both the oriented sections of the tangential port and the direct flow segment of the helical port are generally similar to oval, round or square approximation. Despite the evident differences in cross-section curve shapes, but in the plane perpendicular to the gas flow direction, cross-section curve shows symmetric characteristics. Therefore, only a quarter-section curve is established by the mathematical equations, the rest of the curves can be characterized by the mirror feature method.

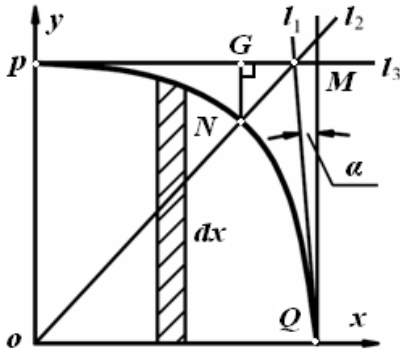

Fig. 2 Structural feature of cross-section curve

The function of cross-section curve in the Cartesian coordinate system is  $g(x)$ , and  $Q(x_0, 0)$  is the intersection point of the curve and  $x$  axis,  $P(0, y_0)$  is the intersection point of the curve and  $y$  axis.  $a$  is the draft angle, its rang is  $3\sim 5^\circ$ , the slope and equation of line  $l_1$  are:  $k_1 = \tan(\alpha + \pi/2) < 0$  and  $y = k_1(x - x_0)$ , respectively.  $y = y_0$ , the point  $M((x_0 + y_0/k_1), y_0)$ , which is made from  $l_1$  and  $l_3$ , can be confirmed, as Fig. 2 shown. Accordingly, the equation of line  $l_3$  is

$$y = k_2 x = \frac{k_1 y_0}{k_1 x_0 + y_0} x \quad (4)$$

Assuming the distance between  $M$  and  $N$ ,  $|MN| = \lambda$ , according to the slope of line  $l_2$ :  $\beta = \tan^{-1}(k_2)$ ; such as in  $Rt\Delta MNG$ ,  $|MG| = \lambda \cos \beta$  and  $|NG| = \lambda \sin \beta$ ; according to the conditions above and the value of known point  $M$ , the intersection  $N$  on line  $l_2$  can be calculated, as shown in the Eq. 5

$$\begin{cases} x_n = x_0 + y_0 / k_1 - \lambda \cos \beta \\ y_n = y_0 - \lambda \sin \beta \end{cases} \quad (5)$$

By the Eq. 5, the coordinate position of point  $N$  is the univalent function about  $\lambda$ , the curve sharp changes along with the changing of  $\lambda$ . The closed region area  $A(\lambda)$ , which is formed by curve  $g(x)$  and coordinate axis, when  $\lambda$  infinitely tends to 0, and the maximum sectional area  $A(\lambda)_{max}$  will approximate to the area of right trapezoid  $PMQO$ , the relationship between them is

$$A(\lambda)_{max} = \lim_{\lambda \rightarrow 0} \int_0^{x_0} g(x) dx \quad (6)$$

$$A(\lambda)_{max} \approx A_{PMQO}(\lambda \rightarrow 0) \quad (7)$$

As the value of  $x_0$ ,  $y_0$  and  $\lambda$  can be determined by the design requirements of the inlet port geometry, thus,  $E$ , the intersection point coordinate of  $l_2$  and curve  $PQ$  is

$$\begin{cases} x_e = \frac{(k_1 x_0 + y_0) x_0}{2k_1 x_0 + y_0} \\ y_e = \frac{k_1 x_0 y_0}{2k_1 x_0 + y_0} \end{cases} \quad (8)$$

By the sectional curve characteristics of the inlet port, the numeric range of  $\lambda$  is  $0 < \lambda < |ME|$ . As points  $P$  and  $Q$  are known, the position of point  $N$  shift along with the variation of  $\lambda$ . In the system of coordinates, the generic equation of sectional curve meets

$$(x+a)(y-c) = b \quad (9)$$

where  $a$ ,  $b$  and  $c$  are nonzero constants.

Supposed that  $y = g(x)$  and the factor  $(x+a) \neq 0$ , the curvilinear function  $g(x)$  meets the formula

$$g(x) = \frac{b}{x+a} + c \quad (10)$$

In the Eq. 10, the constants  $a$ ,  $b$  and  $c$  are undetermined coefficients. According to the values of  $P$ ,  $N$  and  $Q$ , and curve  $g(x)$  must pass these three points, all undetermined coefficients can be calculated, the computational formulas are as follows

$$a = \frac{x_0 x_n y_n}{x_0 y_0 - x_n y_0 - x_0 y_n} \quad (11)$$

$$b = \frac{x_0 y_0 x_n y_n (x_0 y_0 - x_n y_0 - x_0 y_n + x_n y_n)}{(x_0 y_0 - x_n y_0 - x_0 y_n)^2} \quad (12)$$

$$c = -\frac{x_n y_0 y_n}{x_0 y_0 - x_n y_0 - x_0 y_n} \quad (13)$$

By now, the basic conditions of forming inlet port section curve have been founded. Firstly, assuming  $x_0 = 25$  mm and  $y_0 = 22$  mm. In MATLAB software, corresponding  $M$  file is built, choosing  $\lambda$  as the equation independent variable, by adjusting the  $\lambda$  values, a series of

curves with evident profile differences will be generated, seen in Fig. 3.

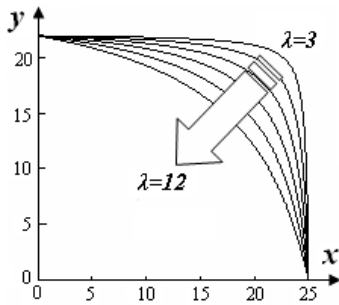

Fig. 3 Curve shape variation with parameter  $\lambda$

In order to build section curve in UG software, curve  $g(x)$  and its equations need to be transformed to distinguished code. Firstly, fix the relative position and dimensions of air inlet entrance at side of cylinder head. Take the centre of inlet port entrance section as the origin point, a relative coordinate system is founded, running the law curve command, the generated plane curve form is as Fig. 4 shown.

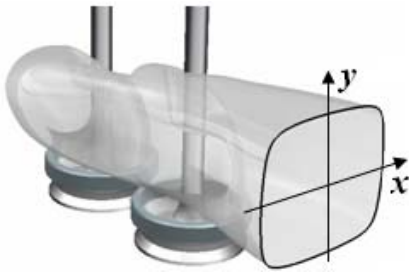

Fig. 4 The sectional curve of the inlet position

### 3. Numerical simulation of the steady-state flow

#### 3.1. Visualization of gas flow in intake process

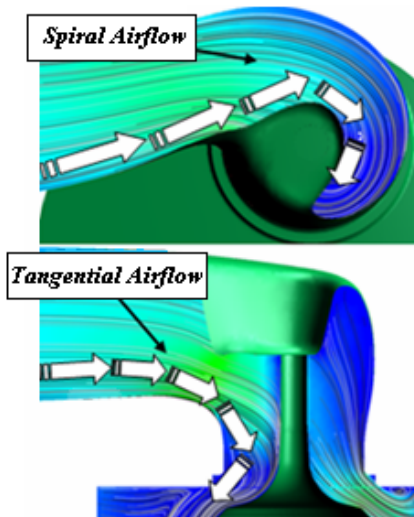

Fig. 5 The internal velocity field streamlines

The velocity field streamlines can be seen in Fig. 5: after the air flows into the helical intake port entrance, it is approximately divided into two shares of the airflows, a part of them entering into the spiral chamber through the valve forms strong air-rotation motion, the

other directly passes into the cylinder along the valve cone angular direction, i.e. so-called spiral airflow and tangential airflow, respectively. The distribution ratio of two parts is directly related to the flow capacity and the formed swirl intensity. If to change its overall performance of the intake port, it should adjust the allocation proportion of flow rate and flow direction of the two streams. Due to the mutation of the air flow direction, the hindrance force blocking fluid motion is formed, which causes the local energy loss, the rotated movement around the cylinder axis is strengthened in the cylinder, whereas the intake efficiency is reduced. On the other hand, tangential airflow without passing through helical chamber flows into the cylinder directly, and the energy loss is relatively smaller.

#### 3.2. Evaluation parameters and performance analysis

For searching for the sensitive areas where impacts the performance of intake port observably, the comparative analysis of the flow field for two intake ports with quite different structure form is carried through to seek the sensitive locations. At the maximum valve lift, the simulation results show that the flow coefficient is 0.658 for the inlet model I, while the model II as high as 0.736. Based on the above two kinds of intake ports it is not difficult to discovery that based on velocity streamlines charts: (1) for the inlet model I, after the tangential air flowing into the virtual cylinder the rotary movement around a axis that perpendicular to the cylinder axis emerges at the bottom of valve plate, which indicates the formation of tumble. The inlet model II in the virtual cylinder has not formed strongly air rotation airflow around the axis of cylinder, but split into more tiny vortices; (2) from the structure shape properties, there are significant differences between the two models, which demonstrating that by adjustment structure shape of the inlet port by small-scale it can be achieved more changes in the intake performance [9], as shown in Fig. 6.

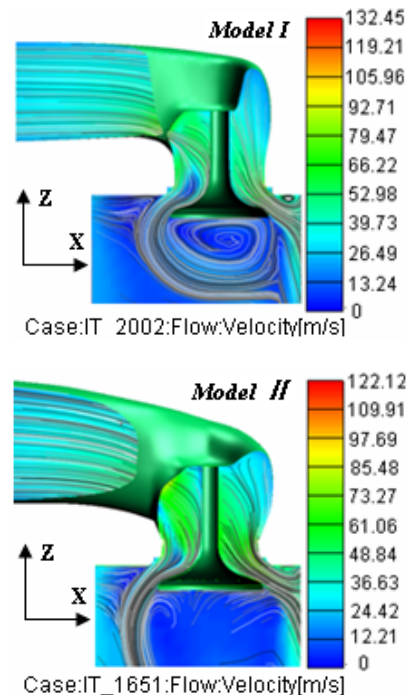

Fig. 6 The streamline chart of velocity field

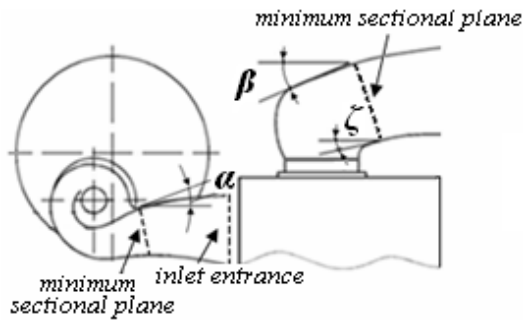

Fig. 7 The definition of structural parameters

With the purpose of interpreting impact of shape properties on performance of intake port, defining three main structural parameters, it includes: (1) transition angle  $\alpha$ , which is the angle of the minimum cross-section normal located the transition section between helical segment and direct flow one with inlet entrance plane normal. (2) Helix slope angle  $\beta$ , the intersection angle between tangent line of helical slope surface and the entrance plane normal. (3) The angle formed by the entrance plane normal and the tangent line of the bottom surface is defined as the bottom slope angle  $\zeta$ , as illustrated in Fig. 7.

To verify the influence of structural parameters on volumetric efficiency of intake port, adjusting the parameters and implementing simulated calculation by means of a lot of simulation data analysis and accumulated experiences, it is found that structural parameters for performance influence shows a certain regularity, which could be realized from Fig. 8. 1. With the transition angle  $\alpha$  and the bottom slope angle  $\zeta$  increases, the swirl intensity becomes weaker, giving rise to a corresponding increase in volumetric efficiency, which is due to airflow entering into the cylinder directly has been significantly enhanced. 2. The influence of helix slope angle  $\beta$  on the inlet performance did not show a fixed rule, so according to this parameter it is difficult to make direct judgments for performance change trend. From the above analysis, it is known that the transition angle  $\alpha$  and the bottom slope angle  $\zeta$  are all very important structural parameters. Meanwhile, the minimum cross-section position is one of the most sensitive areas for helical intake port.

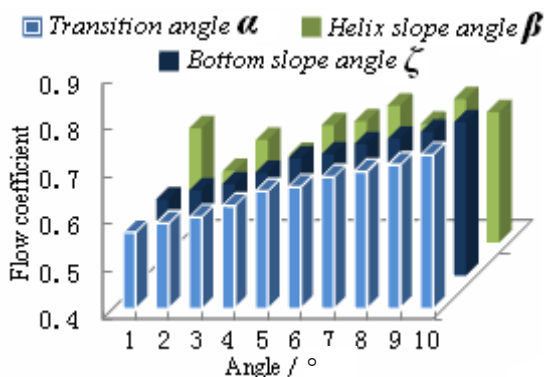

Fig. 8 Variation trend of flow coefficient with parameters

### 3.3. Adjustment of the physical model

Since most of the controlled trajectory curves are all formulized or associated bridge curved features, the spatial surface will change along with the adjustment of curves distribution. In the process of creating the intake

port model, the overall design concept is critical, we should focus on the sequence of generating the curves or surfaces and the associated matching characteristics, so curved surface can be updated automatically. By adjusting the structural parameters, a series of inlet physical models can be obtained. Finally three design schemes are identified. The first step is to acquire sand core model of inlet port model, and then cast into cylinder head products depending on CAD models. The main difference is the structure shape of helical segments, on account of the distribution of cylinder head bolts, the direct flow segment shape essentially remains unchanged.

## 4. The steady-state flow test

### 4.1. Experimental method and general conditions

The horizontal two-cylinder direct injection diesel engine is selected as the test object, its basic specifications are: Bore  $D$  is 115 mm and Stroke  $S$  120 mm.

Test environmental conditions:

1. the atmosphere pressure at high altitude is 81.6 kPa;
2. laboratory indoor temperature is 295.15 K;
3. the air density is equal to 1.058 kg/m<sup>3</sup>.

The AVL evaluation method of inlet performance is put into implement in the test. The cylinder head production workflow based on CAD/CAM is not elaborated here. During actual production process of cylinder head, the casting deviation and machining error will lead to the relative position deviation among valve guide pipe, valve seat and the intake port that dissatisfying the design requirements, hence it should try to reduce the impact of casting process on the inlet properties.

Furthermore, to verify the reliability of simulation results, the calculated values are compared with the experimental data. The integration way of numerical simulation and experimental study can fully understand the gas flow in the cylinder [1]. At the maximum valve lift, the calculated values compares with the experimental values aiming at swirl ratio and flow coefficient of the three intake ports. In Table it shows that: the maximum deviation of the flow coefficient and swirl ratio between calculated and experimental values are 3.5% and 5.4%, respectively. The simulation results are consistent with the experimental data in the total tendency.

Table  
Comparison of test values and calculated ones

Cylinder head	Flow coefficient		Swirl ratio	
	Calculated values	Experimental values	Calculated values	Experimental values
No.1	0.691	0.676	1.65	1.74
No.2	0.673	0.651	1.72	1.81
No.3	0.658	0.635	1.95	2.01

### 4.2 Test results comparison

From Figs. 9 and 10 it can be known that: the flow coefficient of cylinder heads which are included three different intake ports increases with the valve lift rising. When being the lower valve lift, as valve opening is little, air flows through the throat position, and the circulation

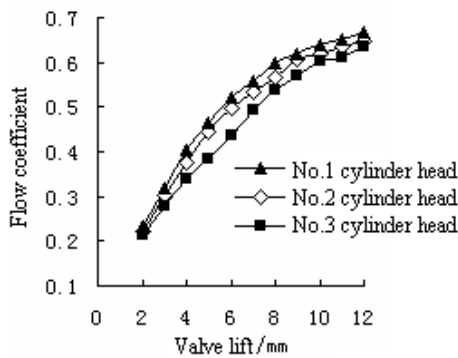

Fig. 9 Flow coefficient curves at different valve lifts

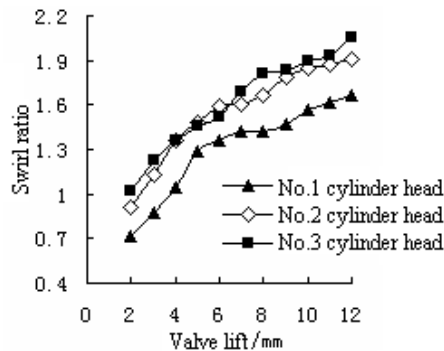

Fig. 10 Swirl ratio curves at different valve lifts

area is smaller, so the throttling effect is remarkable accordingly, and flow coefficient are not obviously different in the low valve lifts. With the increase of valve lift, the air circulation area also become larger, the structure geometry of the intake takes the dominant role in flow capacity at present, the quantity variance of flow coefficient are extremely different among the various intake ports. Swirl intensity is also strengthened equally with the increase of the valve opening level. For No. 2 of cylinder head the average swirl ratio is maximum, while cylinder head No. 3 is minimum, nevertheless flow coefficient variation is the opposite accordingly. This is just because the flow coefficient and swirl ratio are two dimensionless parameters and contradictory factors. To improve flow capacity of inlet, the swirl strength which is formed in the cylinder will be weakened subsequently.

## 5. Conclusions

1. On the basis of the advanced design method, the multivalve physical model can be directly constructed by the way of combination of the spiral equations and the associated sectional curves. According to digital model, the intake port can be rapidly processed into wooden core boxes.

2. The inlet space curves are built up based on the mathematical equations, by changing the corresponding parameters the shape of curves is also altered, the multivalve intake port models is more robust.

3. Adjusting the structure parameters of the transition angle  $\alpha$ , the helix slope angle  $\beta$  and the bottom slope angle  $\zeta$ , the inlet performance shows notable alteration at the maximum valve lift, and their flow coefficient varies from 0.563 to 0.736.

4. Cylinder head products are fabricated based on the identified schemes. The test results are comparable

with the calculated values, and the relative errors between the both values are all less than 6%. Therefore the simulation results can perfectly predict the variation tendency of inlet performance.

## References

1. **Kang, Y.; Chang, H.; Ryol Choi; Jong Gyu Kim.** 1995. Flow analysis of the helical intake port and cylinder of a direct injection diesel engine. SAE Paper 952069.
2. **Padmesh Mandloi; Gunjan Verma.** 2009. Design optimization of an in-cylinder engine intake port, 2009 Nafems World Congress, Crete (Greece).
3. **Kihyung Lee a; Choongsik Bae; Kernyong Kang.** 2007. The effects of tumble and swirl flows on flame propagation in a four-valve si engine, Applied Thermal Engineering 27(2): 2122-2130.
4. **Vasilyev, A.; Deynichenko, E., Popov, D.** 2005. Internal combustion engine valve gear cam wear and its influence on valve gear and engine efficiency, Mechanika 4(54): 44-49.
5. **Kernel Y Kan; Rolf D Reitz.** 1999. The effect of intake valve alignment on swirl generation in a di diesel engine. Experimental Thermal and Fluid Science 20(4): 94-103.
6. **Bates M.C.; Heikal M.R.** 2002. A knowledge-based model for multi-valve diesel engine intake port design. SAE Paper 2002-01-1747.
7. **WANG Tian-you; LIU Da-ming; SHEN Jie.** 2008. Development of intake ports of four-valve diesel engine. Chinese Internal Combustion Engine Engineering 29(2): 52-55.
8. **Cao Shu-li; Huang Rong-hua.** 2004. CAD and numerical simulation of air flow in double intake ports for 4-valve diesel engine. Internal Combustion Engine Engineering 25(6): 38-43.
9. **Du Farong; Nie Jianjun; Gao Feng.** 2007. An improved design flow chart for the passage of a diesel engine. Mechanical Science and Technology 26(8): 969-972.

He Changming, Xu Sichuan, Zuo Chaofeng, Chen Xin, Li Chuanyou

HORIZONTALAUS DYZELINIO VARIKLIJO DAUGIAVOŽTUVIO ĮSIURBIMO KANALO PROJEKTAVIMAS IR CHARAKTERISTIKŲ OPTIMIZAVIMAS

R e z i ū m ė

Daugiaavožtuvio įsiurbimo kanalo technologija dabar yra plačiai taikoma, tačiau sudėtinga įsiurbimo kana-

lo geometrija apsunkina trimatį tiesioginį modeliavimą. Programos UG ir „Matlab“ buvo išrinktos kaip projektavimo platforma analizuojant tangentinę kanalo orientavimo sekcijos konstrukciją ir spiralinio tekėjimo segmento charakteristikas. Ryšio lygtys, sudarytos taikant analizinės geometrijos metodą, panaudotos tekėjimo charakteristikoms įsiurbimo kanale ir cilindre tirti. CFD imitavimo rezultatai parodė, kad, modifikuojant eksploatacinius parametrus, tokius kaip perėjimo kampą  $\alpha$ , spiralės polinkio kampą  $\beta$  ir dugno polinkį  $\zeta$ , fizinis modelis su akivaizdžiais charakteristikų skirtumais gali būti sukurtas ir, maksimaliai patobulinus vožtuvą, tekėjimo koeficientas keistųsi nuo 0,563 iki 0,736. Maksimali paklaida tarp apskaičiuoto ir eksperimentinio dydžio yra mažesnė, nei 6%. Šis pažangus projektavimo metodas, naudojantis matematinius modelius, pritaikytas daugiavožtuviam įsiurbimo kanalui, padės sudaryti sudėtingos konstrukcijos CAD modelį ir leis optimizuoti charakteristikas.

He Changming, Xu Sichuan, Zuo Chaofeng, Chen Xin,  
Li Chuanyou

MULTIVALVE INTAKE PORT PARAMETRIC  
DESIGN AND PERFORMANCE OPTIMIZATION OF  
THE HORIZONTAL DIESEL ENGINE

S u m m a r y

As the result of basic advantages of multi-valve intake port technology it is widely applied now, but the

complex geometry of the intake port increases the difficulty of three-dimensional direct modeling. The UG and Matlab software were selected as the design platform, through the analyzing the features of the tangential port orientation section and the structural characteristics of spiral flow segment, the relational equations were all established by adopting analytical geometry method, meanwhile the flow characteristics in the inlet port and cylinder was investigated. The CFD simulation results show that: By modification of performance parameters, such as the transition angle  $\alpha$ , helix slope angle  $\beta$  and the bottom slope  $\zeta$ , the physical models with evident performance differences can be regenerated, and at the maximum valve lift, the flow coefficient was altered in the range from 0.563 to 0.736. The relative errors between calculated values and experimental ones are all less than 6%. This advanced design method based on the mathematical models for multi-valve intake ports should be beneficial to directly construct the inlet CAD model with complex structure profile and will meet the design requirements by performance optimization.

Received March 15, 2011  
Accepted December 15, 2011