

Automatic control of longitudinal form accuracy of a shaft at grinding

A.H. Marcinkevičius

Vilnius Gediminas Technical University, Basanavičius 28, 03224 Vilnius, Lithuania, E-mail: Andrius.Marcinkevicius@me.vgtu.lt

1. Introduction

One of the main tasks of accuracy achieving at shaft grinding is to keep accuracy of its longitudinal form with maximal productivity of the process. At many machining processes the problem of accuracy achieving and productivity increase is searched at the control of cutting force component F_z or F_y and keep by it a constant. Although in traverse grinding because of stiffness change of the technological system in longitudinal stroke the constant grinding force does not ensure the accuracy of longitudinal form. New control methods for accuracy achieving were proposed by Y. Gao and K. Forster [1], Y. Gao and B. Jones [2], Cheol-Woo Park et al [3]. Y. Gao and K. Forster for deflection compensation of the slender rollers at grinding proposed to use the correction steadies. Computer simulated prediction of roller deflection was used for optimal adjustment of the steadies. Their active control is described in work [2]. Deflection of the slender workpiece with steadies was also analyzed in work [3]. Longitudinal feed speed in this work is kept constant. Ding N. et al [4] have searched the strategy of adaptive deflection control of the workpiece at traverse grinding. Deflections of a single diameter shaft were controlled by measuring the diameter of the workpiece and automatic change of the workpiece rotation speed v_w and longitudinal feed speed v_t . The special adaptive control system was proposed for cylindrical grinder.

Control and modeling of cutting force is used not only in grinding, but other operations (see e.g. [5]).

Characteristic in [1-4] is that the ratio between the length and the diameter of a slender roller is very large (up to 30-50). For this reason the grinding only with supporting steadies is possible. At moderate ratio between the length and diameter of the shaft (in limits up to 7-8) the

shafts are ground without steadies. The stiffness change of the technological system at longitudinal stroke has significant influence on accuracy. The main influence on accuracy has radial component F_y of the grinding force. Partial solution of the problem is searched by keeping constant this force by the change of cutting rates (in the most cases – longitudinal speed of the traverse stroke), but because of stiffness change in longitudinal stroke the constant grinding force does not assure the accuracy of longitudinal form. The accuracy can be increased at definition of stiffness change dependencies in a longitudinal stroke and keep such value of cutting force which would secure constancy of longitudinal form of the shaft. The mathematical solution of the problem must be found. Our work is committed to it.

The task of this investigation is to define the mathematical dependencies how to regulate the value of cutting force in purpose to keep constancy of longitudinal form of the shaft at grinding. The digital control system is proposed for it. The system consists of measuring transducers which control elastic displacement of center pins at grinding and keeps their previously calculated necessary sum of displacements by automatically controlled longitudinal feed speed. Because generally multistep shafts are used in machines, the multistep shaft is analyzed in the work.

2. Analysis of dependencies between elastic deflections and cutting rates at traverse grinding

Fig. 1, a shows the scheme of loading of a multistep shaft at general grinding. The i -th shaft neck with coordinate X_{i-1} at the front neck's face and X_i at the rear face is being ground with a longitudinal feed. The grinding wheel width is B . The coordinate of its rear side is xb_1 and

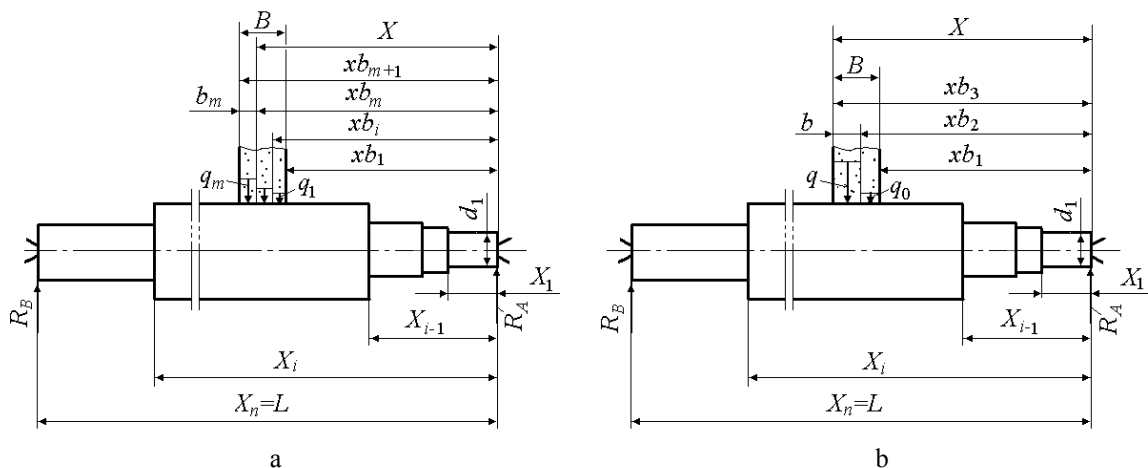

Fig. 1 Loading scheme of a shaft at grinding: a - in common case, b- at keeping constant deflection

of the front side is xb_{m+1} . At one revolution of the shaft the wheel goes in longitudinal direction from coordinate xb_{m-1} to xb_m . The distributed load q_i between the coordinates varies from q_1 between coordinates xb_1 and xb_2 to q_m between coordinates xb_m and xb_{m+1} . If to propose that control system secures the constant allowance on the shaft neck being ground one can see that there will be only two distributed load sections and three coordinates xb (Fig. 1, b): in one section between coordinates xb_2 to xb_3 the wheel cuts allowance u and creates the distributed load q . In the limits from xb_1 to xb_2 the threshold load q_0 at which the wheel only contacts with the workpiece without chip cutting is left. This force is rather small [6, 7].

Elastic deflection y_x from distributed load q_i acting at any position xb_i alongside the shaft width limits $b_i=xb_{i+1}-xb_i$ in common case depend on the sum of deflections of four main components of the technological system: shaft ω_x , center pins y_{cx} , machine tool table y_{tb} , and wheel-head deflections together with a spindle y_{wh}

$$y_x = \omega_x + y_{cx} + y_{tb} + y_{wh} \quad (1)$$

Deflection ω_x of a multistep shaft can be calculated as an equivalent of the one with the reduced its different neck diameters to the diameter of the first neck with proportion

$$\beta_i = J_1 / J_i \quad (2)$$

$$M_p = (\beta_p - \beta_{p-1}) \left(X_{p-1} R_A - \sum_{k=1}^m q_k b_k \left(X_{p-1} - \frac{xb_{k-1} + xb_k}{2} \right) \right) \quad (6)$$

$$F_p = (\beta_p - \beta_{p-1}) \left(R_A - \sum_{k=1}^m q_k b_k \right) \quad (7)$$

$$\omega_x = \Theta_0 X - \frac{1}{EJ_1} \left(\frac{R_A X^3}{6} - \sum_{i=2}^j \left(M_i \frac{(X - X_{i-1})^2}{2} + F_i \frac{(X - X_{i-1})^3}{6} \right) - \beta_j \sum_{k=1}^r q_k a_{1(k)} \right) \quad (8)$$

where Θ_0 is shaft bending angle at its beginning; E is Jung's modulus; $a_{1(k)}$ is coefficient

$$a_{1(k)} = \frac{(X - xb_k)^4 - (X - xb_{k+1})^4}{24} \quad (9)$$

$$\Theta_0 = \frac{1}{EJ_1 L} \left(\frac{R_A L^3}{6} + \sum_{i=2}^n \left(M_i \frac{(L - X_{i-1})^2}{2} + F_i \frac{(L - X_{i-1})^3}{6} \right) - \beta_j \sum_{k=1}^m q_k \frac{(L - x_{bk})^4 - (L - x_{bk+1})^4}{24} \right) \quad (10)$$

Deflection y_{cx} in Eq. (1) in common case is calculated by the formula

$$y_{cx} = \sum_{k=1}^m q_k b_k \left(\left(1 - \frac{xb_k + xb_{k+1}}{2L} \right) \left(1 - \frac{X}{L} \right) \frac{1}{C_A} + \frac{(xb_k + xb_{k+1})X}{2L^2 C_B} \right) \quad (11)$$

where C_A and C_B are stiffness at the tailstock and headstock centre pins accordingly.

Deflection y_{tb} and y_{wh} in Eq. (1) are calculated by the formulae

$$y_{tb} = \frac{1}{C_{tb}} \sum_{k=1}^m q_k b_k \quad (12)$$

$$y_{wh} = \frac{1}{C_{wh}} \sum_{k=1}^m q_k b_k \quad (13)$$

where J_1 is inertia moment of the first neck of the shaft, let it be the neck at the tailstock of the grinder; J_i is inertia moment of any i -th neck.

At the calculation of equivalent shaft the real distributed load acting on the i -th neck is transformed to equivalent load $Q_f = \beta_i \sum_{k=1}^m q_k b_k$ acting in the limits from

xb_1 to xb_{m+1} (the same as for the real shaft). Additionally the equivalent shaft at the coordinates coinciding with the beginning of every neck must be loaded with additional moments and forces. Up to the coordinate X_{i-1} the equivalent shaft must be loaded with additional bending moments M_i and loads F_i

$$M_i = (\beta_i - \beta_{i-1}) X_{i-1} R_A \quad (3)$$

$$F_i = (\beta_i - \beta_{i-1}) R_A \quad (4)$$

there R_A is the reaction at the tailstock center pin (Fig. 1).

$$R_A = \sum_{k=1}^m q_k b_k (2L - xb_k - xb_{k+1}) / 2L \quad (5)$$

there L is total length of the shaft. At coordinates from X_i to X_{n-1} (where n is the total number of shaft necks) additional bending moments and forces are accordingly

Bending value ω_x at distance X from the beginning of the shaft when $xb_1 \leq X \leq xb_{m+1}$ (Fig. 1, a) is

there C_{ib} and C_{wh} are stiffness of the grinder table and of its wheelhead together with the grinding spindle.

As mentioned above it can be seen that at grinding with constant deflection y_x there will be only two distributed loads: q at length b , equal to the force exerted by the grinding wheel at allowance cutting at this length and q_0 at the other length covered by the grinding wheel. At the width of the wheel B this length is equal $B-b$. So in this case the coordinates of distributed load alongside the wheel width will be accordingly xb_1 , xb_2 , and xb_3 , and

$$xb_2 = xb_1 + B - b \quad (14)$$

$$xb_3 = xb_2 + b \quad (15)$$

Further equations are deduced for the value X coinciding at longitudinal grinding stroke in direction from tailstock to headstock and equal to the value xb_3 , it is $X = xb_3$ (Fig. 1, b). After insertion of M_i , F_i , and R_A from (3), (4) to (8) and keeping dependencies (14), (15), (8) transforms to

$$\omega_x = \Theta_0 X + b^4 (q - q_0) c_2 + 4b^3 q_0 B c_2 + b^2 q_0 (c_2 c_3 - 6B^2 c_4) + b (4B^3 q_0 c_4 - c_1 c_2 c_3) + B^2 q_0 (c_2 c_3 - B_2 c_4) \quad (16)$$

where

$$c_1 = q(2L - X) - q_0(2L - X - B) - B^2 q_0 \quad (17)$$

$$c_2 = \frac{\beta_j}{24EJ_1}, \quad c_3 = \frac{1}{2LEJ_1} \quad (18)$$

$$c_4 = \frac{X^3}{6} - \sum_{i=2}^j (\beta_i - \beta_{i-1}) \left(X_{i-1} \frac{(X - X_{i-1})^2}{2} + \frac{(X - X_{i-1})^3}{6} \right) \quad (19)$$

Eq. (10) of angle Θ_0 will be expressed by the formula

$$\Theta_0 = -b^4 (q + q_0) c_2 - b^3 (q + q_0) 4c_2 (L - X) - b^2 c_5 + bc_6 + c_7 \quad (20)$$

where

$$c_5 = 6c_2 (L - X)^2 (q + q_0) + q_0 c_3 c_8 / L + c_3 c_9 (q - q_0) \quad (21)$$

$$c_6 = c_1 c_3 c_8 / L + [(q - q_0)(c_{10} + c_{11}) + qc_9 X - 4(q + q_0)c_2 (L - X)^3] \quad (22)$$

$$c_7 = -q_0 \{ B^2 c_3 c_8 + c_3 [(c_{10} + c_{11})B + c_9 B(X - B/2)] - (L - X)^4 q_0 + (L - X)^4 q_0 \} \quad (23)$$

$$c_8 = \frac{L^3}{6} - \sum_{i=2}^n (\beta_i - \beta_{i-1}) \left(X_{i-1} \frac{(L - X_{i-1})^2}{2} + \frac{(L - X_{i-1})^3}{6} \right) \quad (24)$$

$$c_9 = \sum_{i=na+1}^n (\beta_i - \beta_{i-1}) \frac{(L - X_{i-1})^2}{2} \quad (25)$$

$$c_{12} = \frac{(q - q_0)(L - X)}{2L^2 C_A} - \frac{qX}{2L^2 C_B} \quad (31)$$

$$c_{10} = \sum_{i=na+1}^n (\beta_i - \beta_{i-1}) \frac{(L - X_{i-1})^2}{2} X_{i-1} \quad (26)$$

$$c_{13} = \frac{(q - q_0)(L - X)^2}{L^2 C_A} - \frac{q_0 B(L - X)}{2L^2 C_A} + \frac{qX^2}{L^2 C_B} - \frac{q_0 BX}{2L^2 C_B} \quad (32)$$

$$c_{11} = \sum_{i=na+1}^n (\beta_i - \beta_{i-1}) \frac{(L - X_{i-1})^3}{6} \quad (27)$$

$$c_{14} = \frac{Bq_0(L - X)^2}{L^2 C_A} + \frac{Bq_0(2X - B)X}{2L^2 C_B} \quad (33)$$

Eqs. (11)-(13) will be expressed as

$$y_{cx} = b^2 c_{12} + bc_{13} + c_{14} \quad (28)$$

$$y_{ib} = \frac{b(q - q_0)}{C_{ib}} + \frac{Bq_0}{C_{ib}} \quad (29)$$

$$y_{wh} = \frac{b(q - q_0)}{C_{wh}} + \frac{Bq_0}{C_{wh}} \quad (30)$$

By insertion of equations (16), (20), (28) – (30) to Eq. (1), the later can be rewritten as

$$y_x = b^4 D_1 + b^3 D_2 + b^2 D_3 + bD_4 + D_5 \quad (34)$$

where

$$D_1 = -(q - q_0)c_2 X + (q - q_0)c_2 X / L \quad (35)$$

There

$$D_2 = -4(q + q_0)(L - X)c_2X/L + 4q_0Bc_2 \quad (36)$$

$$D_3 = -c_5X + q_0(c_2c_36B^2c_4) + c_{12} \quad (37)$$

$$D_4 = c_6X + 4B^3q_0c_4 - c_1c_2c_3 + c_{13} + (q - q_0)(1/C_{ib} + 1/C_{wh}) \quad (38)$$

$$D_5 = c_7X + B^2q_0(c_2c_3 - B^2c_4) + c_{14} + Bq_0(1/C_{ib} + 1/C_{wh}) \quad (39)$$

So all the values of y_x in Eq. (1) are expressed through grinding width b of the shaft surface being ground and adequate coefficients from D_1 to D_5 .

3. Practical use of deduced dependencies

At keeping y_x constant ($y_x = const$) by automatic control of the cutting force F_y , the task is to define its value and how the value of b should be changed in longitudinal stroke. For the definition of value b there are limitations: at rough grinding it should not exceed $0.8B$, at fine and spark out grinding it should not exceed $0.4B$. Values X_i , β_i , J_i figuring in coefficients of equations are got from the shaft drawing, stiffness C_A , C_B , C_{ib} , C_{wh} are defined experimentally. Distributed load q is defined by the equation [6]

$$q = uv_wk_w + q_0 \quad (40)$$

where u is allowance being cut from the shaft; v_w is revolution speed of the workpiece; k_w is force coefficient showing what the force, N is created in length unit at cutting in it metal volume, mm^3/s ; q_0 is initial load of the threshold force on width unit.

According to our research [6] for average structural steel $q=2.2 \text{ N}/(\text{mm}^3/\text{s})$, $q_0=0.13 \text{ N}/\text{mm}$. The precision grinding consists of three cycles: rough, fine and spark out grinding. Allowance u (mm) at rough grinding with the cutting speed 50 m/s and workpiece speed $v_w=30 \text{ m}/\text{min}$ must be selected in the limits that there would not be burns on workpiece surface. This limit by the

data of many researchers for 1 mm length unit of the surface being ground is $q=7.5 \text{ N}/\text{mm}$. For fine machining with the purpose to achieve good surface layer quality $q=3 \text{ N}/\text{mm}$. At spark out grinding $q \rightarrow q_0$.

So all the values necessary for y_x calculation are known with the exception of traverse grinding position at which the maximal value b will be got. It is defined in such a case. Let the value $b = b_{max}$, $q=7.5 \text{ N}/(\text{mm}^3/\text{s})$ and others be inserted into Eq. (34) at any initial position X of traverse grinding and y_x will be calculated. Using this value of y_x and changing the value of X we shall find by Eq. (34) in what position really the b is maximal, and limited b_{max} will be taken for this position. y_x is necessary to recalculate according to the found b_{max} . After that the change of b value and the necessary force F_y which must be kept by the control system at longitudinal stroke for keeping y_x constant is found by Eq. (34). Knowledge of the force F_y enable to define what value of center pins deflection is necessary to keep at grinding. It can be expressed by the equation

$$y_s = F_y (1/C_{Am} + 1/C_{Bm}) \quad (41)$$

where C_{Am} and C_{Bm} are stiffness of center pins at the tailstock and headstock accordingly.

The calculation of deflection change for grinding stroke direction from tailstock to headstock and when the value X coincides with the value xb_3 is described in the paper. For grinding in traverse direction calculation methodic is the same, only in Eqs. (14), (15) the values xb_2 and xb_3 will be different, $xb_2 = xb_1 - B + b$; $xb_3 = xb_2 - b$. Other calculations are the same, but it should be kept in mind that at the beginning and the end of a traverse stroke the grinding wheel will cover the workpiece not by all its width, so the load q at the length b will act only, and at the other width there will be no load.

4. Scheme of control system

Fig. 2 shows the scheme of the closed loop control system. Initial sum of center pins displacement y_{s1} for

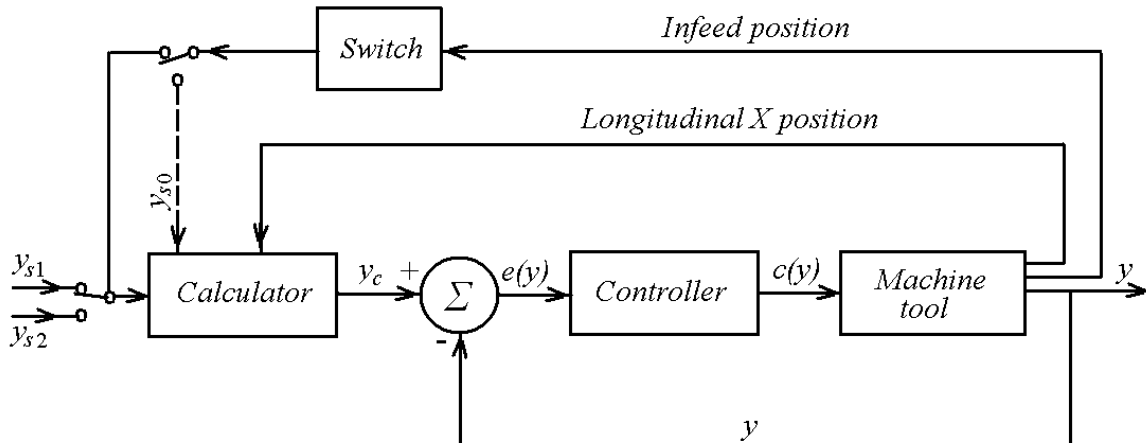

Fig. 2 Scheme of the control system

rough or y_{s2} for fine grinding which depends on cutting force F_y (see Eq. 41) is got by program, the first of them from the beginning of the grinding, the second after the grinding wheel will reach position for switching from rough to fine grinding. These values are got constant for all strokes of rough or fine grinding and are defined in dependence on allowable load q N/mm for rough or fine grinding. Deflection from y_{s1} to y_{s2} is switched out depending on the grinding wheelhead infeed position. The initial value of this displacement is got to calculator for every stroke and it corrects the value according to longitudinal position X of the shaft in the stroke. This position is measured at table motion of the grinder. Corrected by the calculator signal y_c in Σ is compared with real signal y got at grinding, and tracing error $e(y)$ is put to the controller which produces control signal $c(y)$ of machine tool control.

After reaching the spark out position the displacement being controlled will be switched to y_{c0} . Its set vale, differently from values y_{s1} and y_{s2} is not constant at every longitudinal stroke of spark out grinding, but changes fro stroke to stroke because after every stroke the allowance left for grinding, so the elastic stress, will decrease. Its initial value for every stroke will be put to calculator and it will change it alongside the stroke length.

Longitudinal position of the table of programmed grinders and of crossfeed slides is measured by the encoder or linear measuring systems [8, 9], so there is no difficulty to program longitudinal feed speed. The force acting on center pins of the grinder can be measured by special center pins, e.g. [10] and summed by the summing device of controller. For this reason to use automatic control of longitudinal form accuracy of a shaft at grinding is not a hard problem.

Automatic control enables not only to increase form accuracy, but productivity as well because form of piece will be kept accurate from the very beginning and it will not be necessary to use additional strokes for accuracy correction. Also automatically controlled longitudinal feed and force stabilize the system against chatter because at the beginning of chatter excitation cutting force begins to change, the system of automatic control reacts to it, changing the longitudinal feed, and it damps oscillations in the system.

5. Conclusion

Automatic control systems keeping constant grinding force in traverse grinding can not secure accurate longitudinal form of the workpiece because of technological system stiffness change in a longitudinal stroke. The method is proposed how to calculate the grinding force change in longitudinal stroke which would keep constant deflection in the system.

References

1. **Gao, Y., Forster, K.** Computer simulation of the deformation of slender, multidiameter rollers during grinding.-Int. J. of Machine Tools and Manufacture, 1991, v.31, No1, p.83-93.
2. **Gao, Y., Jones, B.** Control of the transverse grinding process using dynamically active workpiece steadies.-Int. J. of Machine Tools and Manufacture, 1993, v.33, Issue 2, p.231-244.
3. **Cheol-Woo Park, Dae-Eun Kim, Sang-Jo Lee.** Shape prediction during the cylindrical traverse grinding of a slender workpiece.-J. of Materials Processing Technology, 1999, v.88, Issues 1-3, p.23-32.
4. **Ding, N., Wang, L.S., Li G.F., Meng, F.Y., Chen, D.M.** Intelligent optimization control of workpiece deformation for traverse grinding. -Intelligent Materials, 2004, v.259-260, p.333-337.
5. **Karabegović, M. Jurković, M. Bejdić.** Mathematical modeling of the main cutting force at turning. -Mechanika. -Kaunas: Technologija, 2004, Nr.3(47), p.59-63.
6. **Marcinkevičius, A.H.** Stability of grinding processes and machine tool work.-Vilnius: Technika, 1995.-312p. (in Lithuanian).
7. **Marcinkevičius, A.H.** Influence of technological system properties and kinematics of workpiece movement on quality characteristics in cylindrical transverse grinding.-Mechanika.-Kaunas: Technologija, 2000, Nr.5(25), p.72-76.
8. **Grinding.com-Studer.** http://www.grinding.com/machines/pages/content/machines_cylindrical_studer.html, 2008.
9. **Taiwan www.machinetools.net.tw.** Machinesources. http://www.Machinetools.net.tw/Grinder/taiwan_cnc_cylindrical_grinder.htm, 2008.
10. **Bučinskas, V., Marcinkevičius, A.** Analysis of measurement of cutting forces by elastic center pins. -Matavimai 2(26).-Kaunas: Technologija, 2003, p.19-23 (In Lithuanian).

A. H. Marcinkevičius

ŠLIFUOJAMO VELENO IŠILGINĖS FORMOS TIKSLUMO AUTOMATINĖ KONTROLĖ

R e z i u m ė

Pjovimo jėgos automatinė kontrolė ir jos pastovumo palaikymas šlifuojant neužtikrina veleno išilginės formos tikslumo, nes sistemos standumas išilginės eigos ilgyje keičiasi. Todėl pasiūlytas valdymo būdas, kai apskaičiuojama ir palaikoma tokia reikiama pjovimo jėga, kuri užtikrintų tampriųjų poslinkių pastovumą šlifuojant, o kartu ir išilginės formos tikslumą. Pjovimo jėga šlifuojant matuojama pagal atraminių centrų deformaciją, o automatinio valdymo sistema palaiko iš anksto apskaičiuotą pjovimo jėgą, keisdama išilginį pastūmos greitį. Straipsnyje pateiktos tampriųjų poslinkių apskaičiavimo lygtys ir parodyta poslinkių priklausomybė nuo technologinės sistemos elementų standumo. Pateikta principinė valdymo sistemos schema.

A.H. Marcinkevičius

AUTOMATIC CONTROL OF LONGITUDINAL FORM
ACCURACY OF A SHAFT AT GRINDING

S u m m a r y

Control and keeping constant the cutting force does not ensure accuracy of longitudinal form at shaft grinding because of technological system stiffness change in a longitudinal stroke. For this reason the method of control to calculate and keep the necessary cutting force which would keep constant deflections in grinding, i. e. the accuracy of longitudinal form is proposed. Cutting force at grinding is controlled by elastic displacement of centre pins and the system of automatic control keeps the calculated beforehand cutting force by changing the longitudinal feed speed. Equations for the calculation of elastic displacements and dependence of the displacements on stiffness of technological system elements are presented in the paper. Principle scheme of a control system is presented.

А. Г. Марцинкявичюс

АВТОМАТИЧЕСКОЕ РЕГУЛИРОВАНИЕ
ТОЧНОСТИ ПРОДОЛЬНОЙ ФОРМЫ ВАЛА ПРИ
ШЛИФОВАНИИ

Р е з ю м е

Автоматический контроль и поддержка постоянства силы резания при шлифовании не обеспечивает точности продольной формы вала, так как жесткость системы по длине прохода меняется. Поэтому предложен метод управления, при котором рассчитывается и поддерживается такая сила резания, которая обеспечила бы постоянство упругих перемещений при шлифовании, тем самым и точность продольной формы. Сила резания при шлифовании измеряется благодаря упругой деформации центров, а система автоматического регулирования поддерживает заранее рассчитанную силу резания путем изменения скорости продольной подачи. В статье представлены формулы расчета упругих перемещений и показана их зависимость от жесткости элементов технологической системы. Представлена принципиальная схема системы контроля.

Received November 20, 2007