

Development of mortar simulator with shell-in-shell system-problem of internal ballistics

A. Fedaravičius*, V. Jonevičius**, M. Ragulskis***, A. Survila****

*Kaunas University of Technology, Kęstučio 27, 44025 Kaunas, Lithuania, E-mail: alfedar@ktu.lt

**Kaunas University of Technology, Kęstučio 27, 44025 Kaunas, Lithuania, E-mail: vaclovas.jonevicius@mil.lt

***Kaunas University of Technology, Kęstučio 27, 44025 Kaunas, Lithuania, E-mail: minvydas.ragulskis@ktu.lt

****Kaunas University of Technology, Kęstučio 27, 44025 Kaunas, Lithuania, E-mail: arvydas.s@email.lt

1. Introduction

Development of military training equipment is an important factor minimising costs and maximizing training effectiveness [1-4]. The goal of the project is to develop mortar simulators with reusable shells mimicking the combat shooting process. Mortar simulators must be applicable in field training of early career soldiers as well as in different combat training scenarios. Double-mass shell system is exploited. It comprises a ballistic barrel (reusable component) and a warhead (consumable component). The relatively heavy ballistic barrel must be ejected from the barrel of the mortar after the blast. Its flight distance must be only few meters, – so that the operators could quickly collect the reusable external shells. The flight distances of the warhead must be 10 times shorter compared with the combat shells (data from combat firing tables). Moreover, only

one propelling charge in the warhead is allowed - the blast energy must be distributed between the ballistic barrel and the warhead in proper proportions. This project raises several problems. The first is the problem of interior ballistics of two interacting masses. Mass, geometric shape of ballistic barrel and the warhead, quantity and sort of the powder for the propelling charge is to be determined so that initial velocity of the warhead would reach the levels determined in the problem of exterior ballistics [4].

When the required initial velocities of the warhead are determined processes taking place in the stage of internal ballistics can be considered. It can be noted that problems of external and internal ballistics cannot be considered separately -complexity of the analysis is illustrated in Fig.1.

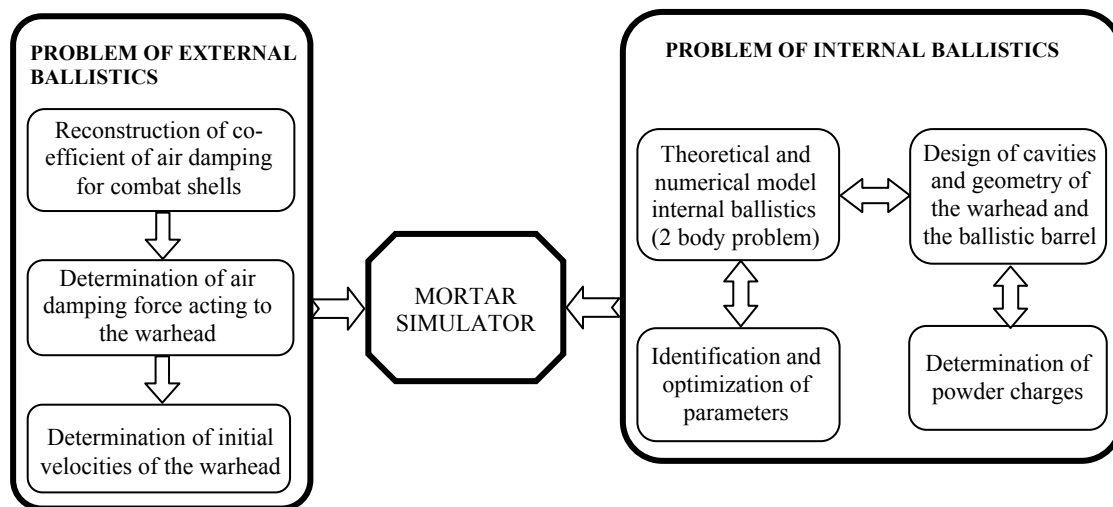

Fig. 1 Development of mortar simulator

2. Phenomenological and mathematical models

Full analysis of the internal ballistics problem would require the solution of chemical, nonlinear fluid and gas dynamics problems [5, 6]. Instead a number of simplifications are assumed in order to develop a phenomenological model of the system presented in Fig. 2 where x_1 is the coordinate of the ballistics barrel; x_2 is coordinate of the warhead; L is the length of the mortar tube; L_1 is the length of the ballistic barrel; L_2 is the depth of the warhead in the cartridge (in status of assembly); l_1 and l_2 are distances of the ballistic barrel and the warhead the from the

bottom of mortar tube in assembly status; R is internal radius of the mortar tube; r is internal radius of the cartridge; e is the thickness of the cartridge wall; p is the thickness of the cartridge bottom; A and B are the volumes under the warhead and the ballistic barrel. In the status of assembly the warhead closes the holes in the cartridge walls, the propelling is located in volume A . When the propelling charge is ignited and the warhead starts moving, the holes are opened and a part of the blast energy is transferred to volume B . The cartridge is assembled with the ballistic barrel and is ejected from the mortar tube - after the warhead is already in its free flight trajectory.

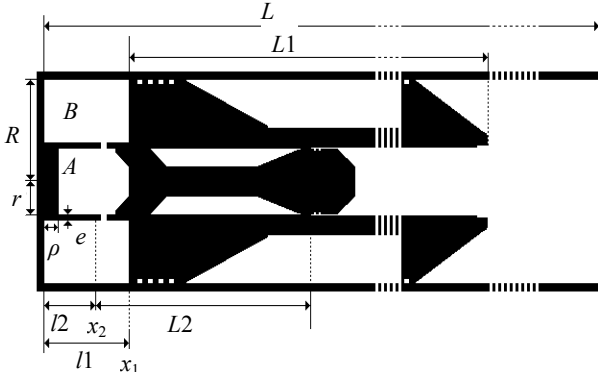

Fig. 2 Schematic diagram of the mortar simulator

The development of phenomenological model of the system suitable for effective numerical simulation and representation of the processes taking place in the stage of internal ballistics requires several assumptions. First is the pressure formulation of the problem. Several sub-problems describing different stages of firing process are formulated using analytical relationships, which are only shortly discussed here due to the space limitations.

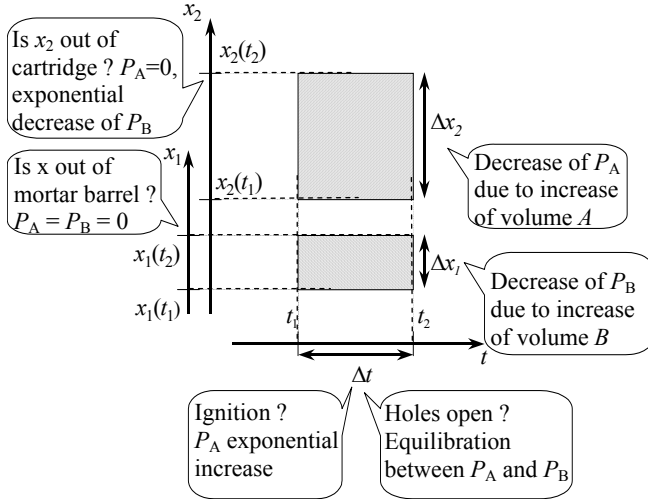

Fig. 3 Pressure formulation of two body internal ballistics problem

First sub-problem describes ignition, exponential pressure increase in volume A , start of the warhead motion and opening of the holes in the cartridge. Next sub-problem describes equilibration of pressures in volumes A and B in depending an exponential way on the holes size. Pressure in volume B moves the ballistic barrel. Next sub-problem describes the relationship between pressure in volumes A and B and coordinates of the warhead and the ballistic barrel. Also it is assumed that the pressure in volume A is zero when the warhead leaves the ballistic barrel. When the ballistic barrel is still in mortar tube but the warhead is out of the cartridge, pressure in volume B decreases exponentially. When the ballistic barrel leaves mortar tube both pressures are assumed to be zero. A set of the coefficients is used to quantify the previously mentioned relationships. For example, the coefficient describing exponential velocity of pressure equilibration between volumes A and B is directly related to total area of the holes in the cartridge.

Next step is the force formulation of the problem. It is assumed that the driving forces acting on the warhead

and ballistic barrel are proportional to the pressures described in the previous step. Friction forces between the warhead and the cartridge are assumed as well as the inertia forces. Finally, a formulation based on variable system structure is developed - its simplified form is presented in Eq. (1), where M and m are masses of the ballistic barrel (including the cartridge) and the warhead; r is coefficient of dry friction between the cartridge and the warhead; F_1 and F_2 are forces recalculated at every time step of integration and acting to the ballistic barrel and the warhead appropriately; P_1 and P_2 - pressures in volumes A and B .

$$\begin{cases} M\ddot{x}_1 + r \cdot \text{sign}(\dot{x}_1 - \dot{x}_2) = F_1(x_1, x_2, P_1, P_2, t) \\ m\ddot{x}_2 + r \cdot \text{sign}(\dot{x}_2 - \dot{x}_1) = F_2(x_1, x_2, P_1, P_2, t) \end{cases} \quad (1)$$

It can be noted that forces F_1 , F_2 and pressures P_1, P_2 are formulated and calculated under assumptions of the phenomenological model of two interacting masses in the problem of internal ballistics [3].

3. Numerical investigations

The problem is solved in MATLAB environment, using iterative algorithm formulation, solving a system of coupled structured differential equations. The first problem of numerical analysis of internal ballistics problem was to simulate and optimise functionality the systems. But the most important goal was to determine the values of system parameters - propelling powder charge, the holes size in the cartridge and the length of the cartridge.

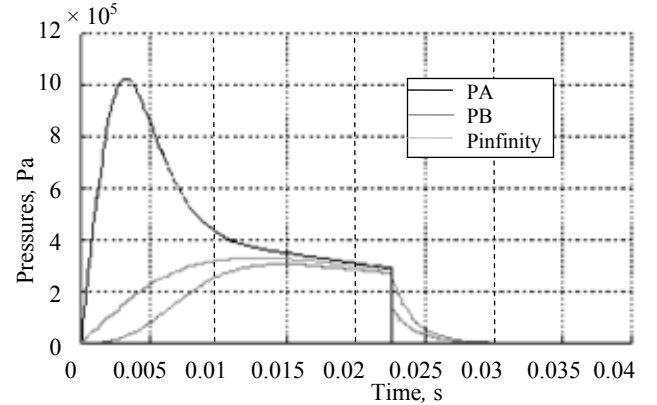

Fig. 4 Pressures in volumes A and B

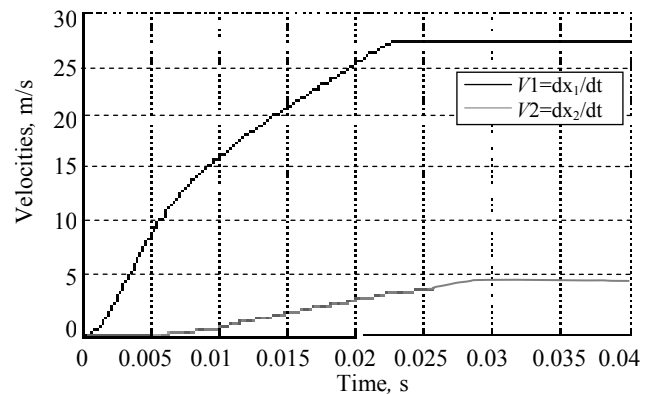

Fig. 5 Velocities of the warhead and the ballistic barrel

Finally, the problems of internal and external ballistics are to be coupled - the velocity of the warhead exiting the ballistic barrel must coincide with the initial velocity determined in the problem of external ballistics; the velocity of the ballistic barrel exiting the mortar tube must guarantee that it flies away about 10 meters from the firing point. Typical results from numerical simulations are presented in Figs. 4 and 5. Variation of pressure and velocity represents the dynamical processes taking place from the moment of ignition up to the moment when the warhead and the ballistic barrel are ejected from the mortar. It can be noted that the parameter $P_{inf\,inity}$ shown in Fig. 5 represents the pressure, which would equilibrate between volumes A and B if coordinates x_1 and x_2 would be frozen. $P_{inf\,inity}$ is not a physical quantity - it is used only in the numerical algorithm, which is based on sequential time and coordinate iterative marching technique.

4. Experimental setup and investigations

Theoretical research of two interrelated masses resulted in the establishment of the basic parameters and characteristics of external and internal ballistics necessary to develop the structure of mortar firing training equipment: initial velocities of separate charges, characteristics of pressure and velocity change during a shot as well as other parameters were determined. A number of assumptions, predetermining the precision and correctness of obtained research results, were made when devising phenomenological and mathematical models. Therefore, it is necessary to experimentally test the obtained research results, to obtain additional information for structural synthesis of the equipment being developed (e.g. to set the quantities of powder of separate charges) and perform testing of the developed equipment on a firing ground.

Experimental research of internal ballistics is very important for structural synthesis of mortar firing training equipment because it has to establish powder quantities of separate charges ensuring appropriate initial velocities of a mine simulator, the area of shell holes (the number of holes), allowing appropriate distribution of powder gas energy, which impacts the warhead and ballistic barrel during a shot, and to create conditions under which the warhead is ejected from the discharge unit earlier than the ballistic barrel is ejected from the mortar barrel, which means that firing according to the trajectories set in the mortar sight is ensured.

To ensure a minimum spread of firing ranges under the same positions of the sight, it is necessary to achieve the same characteristics of the phases of shot initiation and combustion of the main charge powder. The phase of shot initiation has major impact on ballistic characteristics of the shot. Consequently, first of all, experimental research into identity of ignition capsule characteristics was carried out. The research allows to judge about the detonation and combustion of the main charge.

To research the spread of energy characteristics of ignition capsule pressure, techniques and an experimental stand, whose chart is given in Fig. 6, were developed.

As diagrams given in Fig. 7 show the dependencies of pressure of the four ignition capsules on time practically coincide; consequently, conditions of shot initial initiation can be deemed identical.

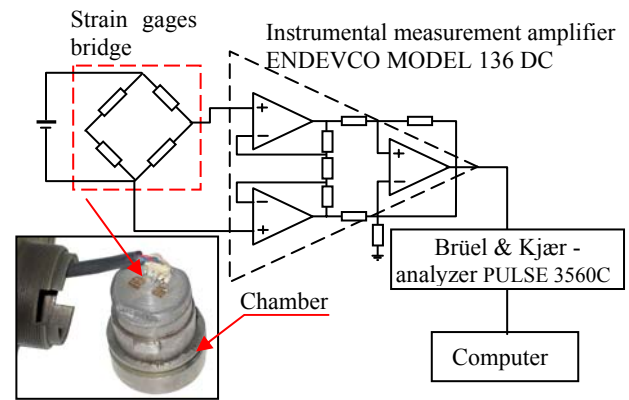

Fig. 6 Chart of experimental stand to research ignition capsule pressure characteristics

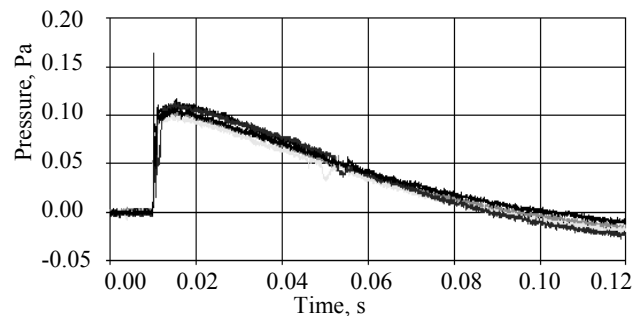

Fig. 7 Diagrams of four ignition capsule pressure dependence on time

As practice has shown ignition capsule energy, however, is not enough to ignite the main charge, therefore a small amount of smoke powder, placed inside the shell above ignition capsule, is applied to improve detonation conditions.

Analogous experimental research of pressure dependencies on time was carried out by initiating the explosion of four ignition capsules with small charges of black powder. Research results are presented in Fig. 8.

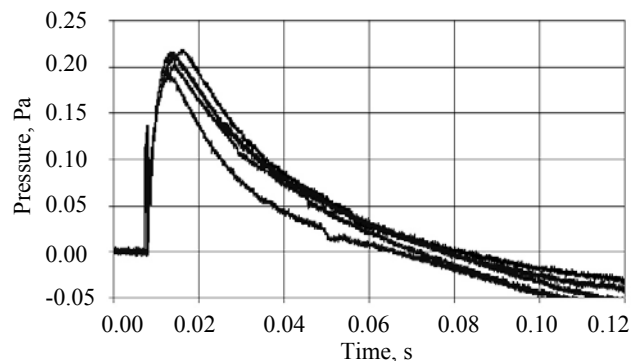

Fig. 8 Diagrams of pressure dependencies of four ignition capsules with small black powder charges on time

Diagrams given in Fig. 8 demonstrate that upon introduction of black powder the pressure change increased up to 10 % but taking into consideration its importance for the ignition of the main charge the error of such value should be deemed satisfactory.

During experiments carried out on a firing ground, the number of shell holes (area) and powder quantities in the main charges necessary to ensure appropriate

firing ranges of the warhead were determined.

Dependencies of warhead range on powder quantities in 60 and 120 mm mortars are shown in Figs. 9 and 10, respectively.

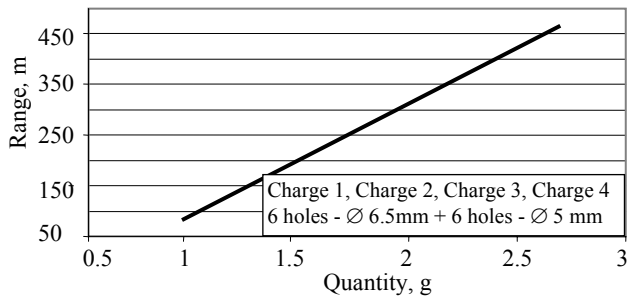

Fig. 9 Dependencies of warhead range on powder quantity in 60 mm mortar

The diagram given in Fig. 9 displays a linear dependence of a warhead range on the powder quantity necessary to initiate it. To ensure the required distribution of gas energy within holes *A* and *B* of the internal ballistics system, a 316.75 mm^2 channel has to be made in the shell (6 holes of $\text{Ø}6.5 \text{ mm}$ and 6 holes of $\text{Ø}5 \text{ mm}$).

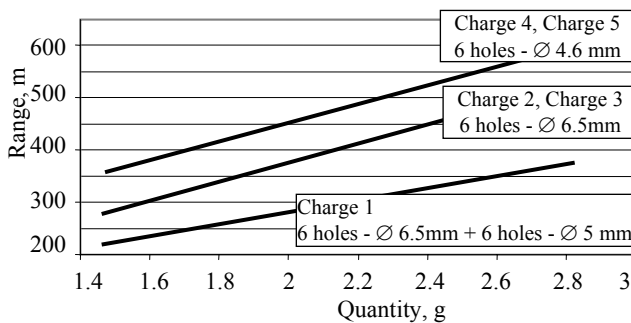

Fig. 10 Dependencies of mine simulator range on powder quantity in 120 mm mortar

Diagrams given in Fig. 10 also show linear dependencies of warhead range on powder quantity in 120 mm mortar. But in order to ensure the ejection of ballistic barrel from the mortar barrel during firing as well as a required range of the warhead, i.e. the proper distribution of gas flows during a shot within holes *A* and *B*, channels of different areas have to be made in the shells of separate charges:

- charge 1 - 316.75 mm^2 (6 holes of $\text{Ø}6.5 \text{ mm}$ and 6 holes of $\text{Ø}5 \text{ mm}$);
- charges 2 and 3 - 198.99 mm^2 (6 holes of $\text{Ø}6.5 \text{ mm}$);
- charges 4 and 5 - 99.66 mm^2 (6 holes of $\text{Ø}4.6 \text{ mm}$).

In this way, with the help of warhead range dependencies on powder quantity shown in Fig. 9 and Fig. 10 diagrams, powder quantities of the main charges in all 60 mm and 120 mm mortars were established and structural parameters of shell gas channels of respective charges were determined.

Experiments of the warhead and ballistic barrel movement within a mortar barrel during firing were carried out on a firing ground by firing all 60 and 120 mm mortar charges. These experimental tests are very important when seeking to determine the fact that the warhead is ejected

from the mortar barrel earlier than the ballistic barrel when using all kinds of charges. This is necessary to achieve that firing takes place according to the trajectories set in mortar's sight.

With this aim in view, oscillations of the mortar barrel during a shot as well as initial velocities of the warhead and ballistic barrel were recorded with oscillation meter and analyzer device PULSE with accelerometer from the company Brüel & Kjær. Separate operation phases of training equipment were determined from the obtained oscillation diagrams: descent of the ballistic barrel with the warhead downwards the mortar barrel; the detonation moment of the main charge, the start-up of ascending of the warhead and the ballistic barrel, and the moment of their ejection from the mortar barrel. For the control of the time moments, measuring impulses of initial velocities are also presented. This allows a more precise establishment of separate operation phases of the training equipment.

Oscillogram depicting a shot process under certain conditions is given in Fig. 11.

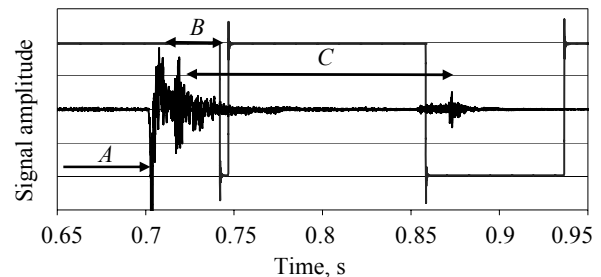

Fig. 11 Oscillogram of mortar training equipment operation phases: *A* – descending of the ballistic barrel with the warhead along the mortar barrel; *B* – warhead movement within the mortar barrel; *C* – ballistic barrel movement within the mortar barrel

It was determined that the time of warhead movement within the mortar barrel in case of all 60 and 120 mm mortar charges accounts for 20 – 25 % of the time of ballistic barrel movement within the barrel. Thus, in all firing cases the warhead is ejected from the mortar barrel much earlier than the ballistic barrel in this way ensuring that all specifications according to mortar sight are strictly observed.

5. Construction of mortar simulator

60 and 120 mm mortar firing training equipment was developed on the basis of performed theoretical and experimental researches of internal and external ballistics of two interrelated masses as well as the stability of mine simulator flight in the atmosphere, and the results of experiments on a firing ground.

The newly developed mortar trainers ensure the training process of firing directly combatant mortar warheads, whose ratio of firing ranges and natural ranges stands at 1:10. To simulate explosion, warheads are filled with smoke powder which, upon having fired at an appropriate range and falling on the ground surface, explode in this way simulating mine explosion.

Taking into consideration the results of per-

formed analysis of projectile run stability within thick atmospheric layers, the structure of the warhead was developed and it was experimentally tested under firing ground conditions. Certainly, seeking to develop a simulator at the lowest possible cost, attempts were made to find the simplest structure of the simulator.

When constructing a warhead with impeller attempts were made to ensure a required stability condition of the structure and to optimize aerodynamic form of the simulator to the maximum extent by bringing it as close as possible to the form of a combatant mine.

Experimental tests of the warhead flight of the

developed mortar trainers varied out on a firing ground showed that according to firing spread parameters it is fully suitable for practical application.

Based on the performed theoretical and experimental research, multiuse shells of respective charges of 60 and 120 mm mortars were developed and together with the warhead they make up a firing set. Furthermore, multiuse mortar ballistic barrels of appropriate calibres, which in fact comply with weight and size parameters of combatant mines, were also developed.

Figs. 12 and 13 shows general views of 60 mm and 120 mm mortar firing training equipment.

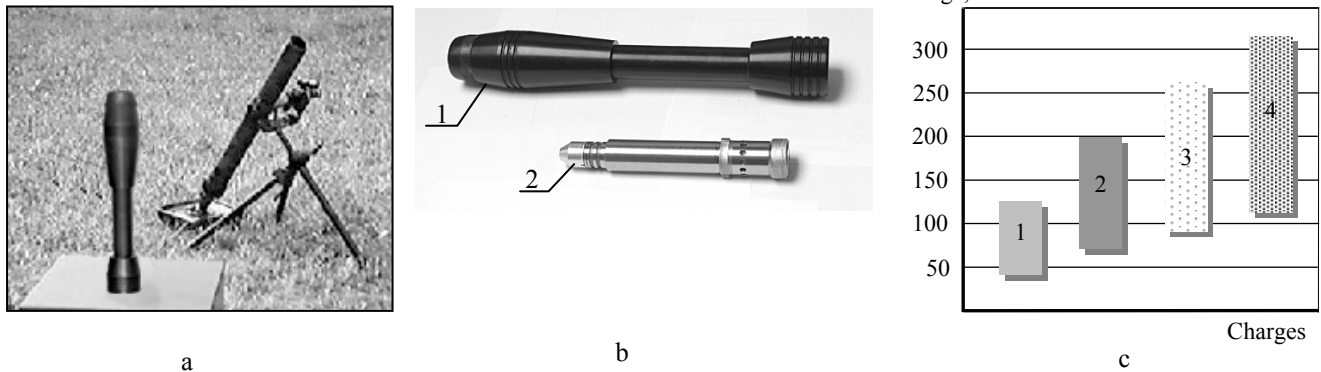

Fig. 12 60 mm mortar trainer: a - mortar trainer; b - training equipment: 1 - 60 mm mortar mine; 2 - "warhead"; c - firing ranges at different charges

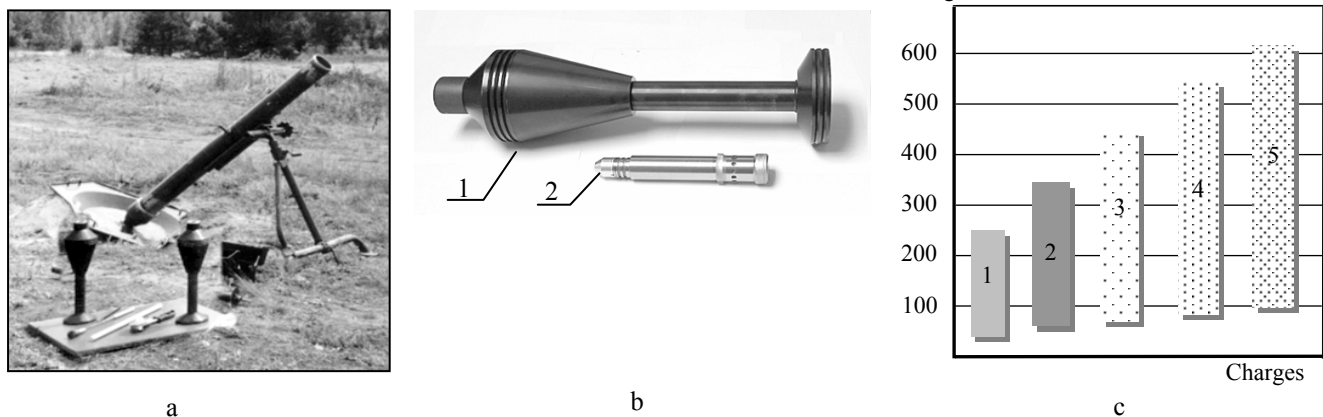

Fig. 13 120 mm mortar trainer: a - mortar trainer; b - training equipment: 1 - 120 mm mortar mine; 2 - "warhead"; c - firing ranges at different charges

60 and 120 mm mortar firing training equipment was implemented in the Lithuanian Armed Force and fully justified itself in practice.

This equipment earned The Lithuanian Product of the Year 2005 title in the field of machine building and was awarded gold medal.

4. Conclusions

1. Phenomenological and mathematical models of internal ballistics of two interrelated masses were developed, their theoretical and computer research was carried out and the characteristics of pressure distribution and velocity of separate masses within the mortar barrel were set.

2. Pressure characteristics of ignition capsules and initiating charges were experimentally researched and it was shown that the pressure characteristics spreads of the

developed initiating charge do not exceed 10% and satisfy practical requirements.

3. The area of shell channels (geometry and number of holes), necessary for appropriate gas pressure distribution during firing, was determined.

4. Dependencies of 60 and 120 mm mortar firing range on the quantity of the main charge powder were set and the amounts of powder necessary for each charge were established.

5. Techniques were devised and experimental research of warhead and ballistic barrel movement within the mortar barrel was carried out; it was determined that the time of warhead movement within the mortar barrel does not exceed 25% of the time of ballistic barrel movement within the barrel, which fully complies with practical firing requirements.

6. 60 and 120 mm mortar firing training equip-

ment was developed and it was implemented and fully justified itself in practice.

References

1. Firearms Training Systems for Military & Law Enforcement Weapon Training Simulation Systems. www.fatsinc.com.
2. Defense Update, International Online Defense Magazine. www.defense-update.com.
3. **Fedaravičius A., Jonevičius V., Ragulskis M.** Development of mortar training equipment with shell-in-shell system. -75th Shock and Vibration Symposium. SAVIAC, Abstracts. -Virginia Beach, Virginia, 2004, October 17-22, p.70-71.
4. **Fedaravičius A., Jonevičius V., Ragulskis M.** Development of mortar simulator with shell-in-shell system-problem of external ballistics. -Mechanika. -Kaunas: Technologija, 2006, Nr.1(57), p.37-40.
5. **Dmitrijevskij A.A.** External ballistics. -Moscow: Mashinostrojenije, 1972.-583p. (in Russian).
6. **Orlov B.V.** Design of rocket and artillery systems. -Moscow: Mashinostrojenije, 1974.-827c. (in Russian).

A. Fedaravičius, V. Jonevičius, M. Ragulskis, A. Survila

MINA MINOJE SISTEMOS MINOSVAIDŽIŲ TRENIRUOKLIO SUKŪRIMAS - VIDINĖS BALISTIKOS UŽDAVINYS

Reziumė

Sudarytas dviejų tarpusavyje susijusių masių vidinės balistikos fenomenologinis ir matematinis modelis bei atliktas jo tyrimas. Atlikti eksperimentiniai tyrimai patvirtino prielaidų, padarytų kuriant modelį, bei gautų teorinių rezultatų teisingumą. Dviejų tarpusavyje susijusių masių išorinės ir vidinės balistikos teorinių ir eksperimentinių tyrimų bei poligoninių bandymų pagrindu sukurta imitacinio šaudymo iš minosvaidžių treniruočių įranga efektyviai panaudota praktikoje.

A. Fedaravičius, V. Jonevičius, M. Ragulskis, A. Survila

DEVELOPMENT OF MORTAR SIMULATOR WITH SHELL-IN-SHELL SYSTEM - PROBLEM OF INTERNAL BALLISTICS

Summary

Phenomenological and mathematical model of internal ballistics of two interrelated masses were developed and researched. Experiments were carried out and they confirmed the correctness of assumptions applied when developing the models as well as obtained theoretical results.

Simulative mortar firing training equipment was developed based on theoretical and experimental as well as firing ground research of internal and external ballistics of two interrelated masses. It has been efficiently applied in practice.

A. Федаравичюс, В. Ионевиčius, М. Рагульскис,
А. Сурвила

СОЗДАНИЕ МИНОМЕТНОГО ТРЕНАЖЕРА ПО СИСТЕМЕ МИНА В МИНЕ - ЗАДАЧА ВНУТРЕННЕЙ БАЛЛИСТИКИ

Резюме

Составлена феноменологическая и математическая модель внутренней баллистики двух взаимно связанных масс и выполнено ее исследование. Проведены экспериментальные исследования подтвердили допущения, сделанные при составлении модели, а также правильность результатов, полученных теоретическим путем. На основе результатов теоретических и экспериментальных исследований, а также полигонных испытаний, полученных при исследовании внешней и внутренней баллистики двух взаимно связанных масс, создано тренировочное оборудование для имитационной стрельбы из минометов, которое эффективно использовано на практике.

Received November 23, 2005