

Hydraulic machine wear control by working regime

N. Zdankus*, V. Kargaudas**

*Kaunas University of Technology, Studentu 48, 51367 Kaunas, Lithuania, E-mail: Narimantas.Zdankus@ktu.lt

**Kaunas University of Technology, Studentu 48, 51367 Kaunas, Lithuania, E-mail: Vytautas.Kargaudas@ktu.lt

1. Introduction

Working liquid (WL) in hydraulic machines (HM) serves as energy transmitter and as lubricant. All slits of friction couples are filled with WL. Dry contact between mobile elements is possible only under immobile conditions. Due to perfect lubrication conditions, the resource of HM is long enough to consider it durable [1, 2]. Some of HM have the resource of 7500 h and even greater [3]. Despite this fact intensive work goes on in many laboratories of the world with the aim of upgrading these rather perfect machines [3, 4].

Our previous research in the field of a slit closure phenomenon [5], also into the development of a speeded up resource testing method of fast swatch plate type hydraulic motor [4] has led us to the study of friction couples. Then a new idea of the control of friction couple wear intensity has originated and later it has been implemented [6, 7].

2. Mechanism of hydraulic machine wear

HM resource testing is an expensive and long lasting process. To collect the mentioned above 7500 h of machine work under constant control and periodical measurements of its parameters requires at least the period of 2 years, a lot of energy resources and qualified work [4].

To increase machine wear intensity and to reduce resource testing time many ways are applied but none of them are acceptable to a speeded up resource testing method. Pollution of WL by abrasive powder, used in a previously functioning laboratory of Fuel Equipment Plant in Vilnius, may be taken as an example of a definitely wrong method for speeding up resource testing.

Overloading, overheating and overspeeding of a machine under resource testing are also not admissible because of violation of the accepted limits of load, temperature, speed as well as the requirements for WL purity. We consider that all parameters of machine regime during its resource testing must satisfy the requirements described in its passport. Thus, in this research the machines under the regimes selected within the limits of admissible velocities, loads, temperatures and purity parameters of WL have been tested.

Determination of the primary reasons of HM wear intensity has been the **aim** of this work. To achieve it the following **tasks** had to be solved:

- 1) analysis of the known and development of new resource testing methods;
- 2) application of the selected methods to real testing;
- 3) determination of the most favourable and the most harmful for HM working regimes.

3. Wear intensity control methods

In the study of machine wear mechanism wear intensity research methods and indicators have been analyzed first at all. The methods used for machine wear research we divide into momentary and integral.

Momentary methods are based on observation of an indicator (friction couple temperature or intensity of wear products emission from the couple) at a given moment of research. Integral methods deal with the results of wear (amount of wear products, change of machine characteristics) during a definite period of time.

Special expensive equipment is necessary for observation, counting and analysis of wear products (metal dust particles) in WL, but because of its unavailability that method has not been applied. A chemical method for determining quantitative characteristics of wear products has proved to be inaccurate, therefore it was also rejected.

Measurement of friction surface temperature appeared rather simple and convenient, therefore it was selected for quick preliminary estimation of friction couple wear intensity during definite regimes of HM. The temperature measurement point was selected at rotor – valve plate contact surface (see Figs. 1 and 2). It is the most sensitive and important friction couple in defining the magnitude of the state and efficiency coefficient of HM in general [2].

The change in temperature started in 1 - 2 minutes and stabilised within 5 - 15 minutes after the change in the regime. The measurements were performed with the accuracy of ± 0.1 °K, when the temperature was fully stabilised and remained constant for 2 - 3 min.

A degree of machine wear in general was determined from a fall of efficiency which was computed from its periodical testing data. In a case of this research into hydraulic motors they were considered completely worn down, when the efficiency coefficient was reduced by 15% from its initial magnitude.

To increase reliability of experimental data three motors of the same type were simultaneously tested. To save the energy for testing we designed and manufactured an experimental stand of a recuperative type. Motors under testing rotated the pumps which loaded the motors and supplied liquid to them. The pumps were of the same type as motors, but their working volumes were slightly smaller. Lack of oil discharge and energy was compensated by an auxiliary pump, which supplied cleaned and cooled WL to the closed circuits pumps-motors of the experimental stand [4, 6].

The motors were tested additionally with nominal speed and the load after each 500 h. Efficiency was read on the $\eta - Q$ dependencies graph and according to its magnitude conclusions about the wear state were drawn.

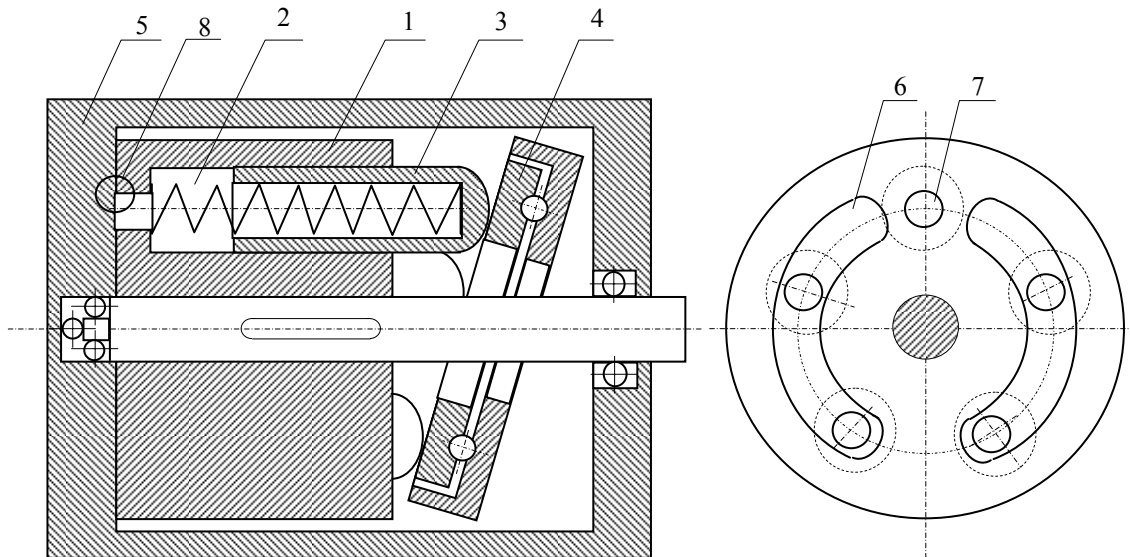

Fig. 1 Scheme of hydraulic machine of axial-piston type: 1 - rotor; 2 - cylinder; 3 - piston; 4 - swash plate; 5 - valve plate; 6 - port; 7 - passage; 8 - friction couple

The first 2000 h of motors test under a nominal load and speed brought no changes in their efficiency.

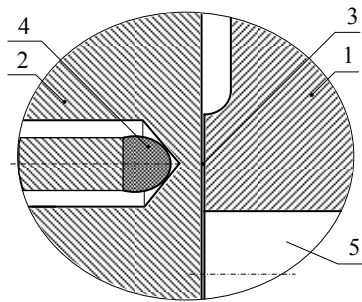

Fig. 2 Friction couple under thermal research: 1 - rotor; 2 - port; 3 - friction couple; 4 - thermocouple; 5 - entrance into cylinder

An increment in load and speed up to maximal admissible one had no influence on wear intensity. Introduction of the reverse each 6 seconds of the maximally loaded and rotating at the highest speed motors also failed to increase wear intensity. Then the mechanism of friction couples wear was analyzed more thoroughly.

4. Influence of machine stops on its wear intensity

It is known [2, 3] that wear of HM working under a stable regime is of minimal intensity because of no direct contact between working surfaces of friction couples. After each stop of HM the WL is being displaced from the slits of friction couples. When the width of a slit reduces to the dimension of roughness element height, a solid contact springs up and wear of the surfaces starts. The wear of HM is especially intensive when friction couple surfaces go into solid contact and out of it in motion.

Displacement of the liquid from slits requires a definite time. If machine stop time is shorter than that required for displacement of liquid up to the solid contact of friction couples surfaces, it has no influence on the wear process. Thus, the mentioned above reverses without pauses do not influence machine wear intensity.

Taking into account the explained above peculiarity we introduced into motors resource testing programme - the reverses with pauses. Duration of pauses ($t_p=6.0$ s) was determined by our previously derived method [5], neglecting the rotation of friction couples elements. The result of such modification of a resource testing regime was immediately noticed in thermal observation of a friction couple (see Fig. 2). The observations were useful for correction and final adjustment of our [4, 6] speeded up resource testing method. Nevertheless, the influence of machine rotation on the friction couples slit closure process remained unclear. For that reason to solve the problem we carried out the analytical research.

5. Closure of friction couple slit

During the slit closure process, when the mobile element of a friction couple (see Fig. 3) rotates, the WL in a slit is acted by both pressure [5] and centrifugal forces. Assume that a flat ring of internal and external radii r_1 and r_2 rotates around its axis Z with angular velocity ω and approaches with velocity v_z the flat solid surface perpendicular to axis Z (see Fig. 3). The slit of friction couple is filled with WL. It is being displaced, when the elements of the couple approaches and the slit closes.

The width of plane ring shape contact surface $(r_2 - r_1)/2$ is small enough to consider the trajectories of fluid particles to be parallel [8]. The pressure in a slit usually is not high to accept WL incompressible and Newtonian, constant flow rate Q along it. The state of the flow is considered quasi-stationary, regime - laminar. Due to a significant mass of friction couple elements the pulsation of pressure [9, 10] is also neglected.

The description given above is rather close to reality and differs from it slightly. Taking into account the possible liquid elastic hysteresis [11], turbidity of the flow in an initial stage of slit closure [12], drifts into non-stationary regime [13], tribo-electrical properties [14, 15] complicate analytical studies of the phenomenon and do not increase but reduce the final result accuracy [16]. We

consider both the thermal regime problems and the influence of a flow rate of the liquid passing the machine to be of a secondary importance [17].

The motion of the liquid in the gap has allowed us to describe it by approximate Navier-Stokes and continuity equations which in the case of polar coordinate system obtain the following form

$$-\frac{v_\phi^2}{r} = \frac{1}{\rho} \frac{\partial p}{\partial r} + \nu \frac{\partial^2 v_r}{\partial z^2} \quad (1)$$

and

$$\frac{1}{r} \frac{\partial(rv_r)}{\partial r} + \frac{\partial v_z}{\partial z} = 0 \quad (2)$$

here v_ϕ and v_r are components of the liquid flow in tangential and radial directions, r is distance from axis Z , ρ is density, p is pressure, ν is kinematical viscosity, v_z is ring motion velocity, z is distance in the direction of axis Z . In the direction of axis Z pressure p is considered constant, i.e. $\frac{\partial p}{\partial z} = 0$.

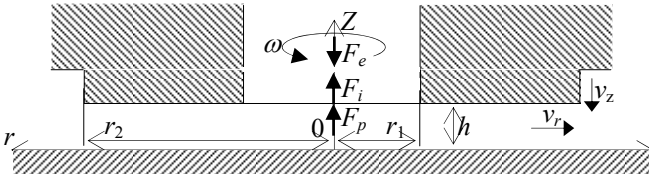

Fig. 3 Rated scheme of a closing slit

Let us express tangential component of velocity v_ϕ in Eq. (1) as follows

$$v_\phi = \omega r \frac{z}{h} \quad (3)$$

where ω is angular velocity of ring rotation, h is slit width. Its twice differentiation allows us to get the expression of v_ϕ - z relationship which, from boundary conditions: $v_\phi = 0$ when $z = 0$ and $z = h$, obtains the form of the following equation

$$v_\phi = \frac{1}{2\mu} \frac{\partial p}{\partial r} (z^2 - hz) + \frac{\omega^2 r}{12\nu} \left(hz - \frac{z^4}{h^2} \right) \quad (4)$$

Integrating continuity Eq. (2) with respect to z and taking into account the direction of the ring motion opposite to the direction of axis Z , the following solution may be obtained

$$v_z = \frac{1}{r} \frac{\partial}{\partial r} \int_0^h rv_r dz \quad (5)$$

Multiplying (5) by rdr and integrating it with respect to r we obtain the following result

$$\frac{1}{2} v_z r^2 + C_1 = \int_0^h rv_r dz = -\frac{rh^3}{12\mu} \frac{\partial p}{\partial r} + \frac{\omega^2 h^3 r^2}{40\nu} \quad (6)$$

Here v_z is taken from Eq. (5), C_1 is constant of integration.

Let us express $\frac{\partial p}{\partial r}$ from Eq. (6), perform integration once again and receive pressure

$$p = -D_c r^2 - \frac{12\mu}{h^3} C_1 \ln r + C_2 \quad (7)$$

where

$$D_c = \frac{3\mu v_z}{h^3} - \frac{3\rho\omega^2}{20} \quad (8)$$

Denoting $p = p_0$ when $r = r_2$ pressure p at distance r from Eq. (7) will receive the following expression of p_0

$$P_0 = D_c \left(\frac{r_2^2 - r_1^2}{\ln \frac{r_2}{r_1}} \ln r - r^2 - \frac{r_2^2 \ln r_1 - r_1^2 \ln r_2}{\ln \frac{r_2}{r_1}} \right) \quad (9)$$

Integrating the difference of pressure $p - p_0$ within the area of the ring we obtain pressure force

$$F_p = \frac{\pi}{2} D_c r_2^2 \psi(n_0) \quad (10)$$

where function

$$\psi(n_0) = (1 - n_0^2) \left(1 + n_0^2 + \frac{1 - n_0^2}{\ln n_0} \right) \quad (11)$$

and its argument

$$n_0 = \frac{r_1}{r_2}$$

When the radius of ring hole r_1 reduces function $\psi(n_0)$ and force F_z reduces rather fast up to the zero when $r_1 = 0$. It means that even a small hole of the ring significantly reduces the pressure force.

Applying Eq. (8) to Eq. (9) and solving it with respect to v_z the following expression is obtained

$$v_z = \frac{2h^3 F_p}{3\pi\mu r^4 \psi_r} + \frac{\omega^2 h^3}{20\nu} \quad (12)$$

For the first approach assuming that inertial force F_i is much smaller compared with pressure force F_p and equalizing the latter to external force F_e we will have the evident proportionality of velocity v_z of external force $F_e = F_p$ to the first power and the cube of slit width h . Angular speed increases the speed, while liquid viscosity ν has a reversal influence.

5. Closure of friction couple slit between rotating elements

Closure of a slit is slow process, acceleration

$a_n = \frac{\partial^2 h}{\partial t^2}$ is small, therefore inertial force F_i is low compared with external force F_e . For the sake of simplicity external force F_e may be equalized to the pressure force F_p . Slit width h reduces in time, therefore velocity v_z has a negative sign in expression $v_z = -\frac{dh}{dt}$. Applying it and denoting in Eq. (12)

$$\frac{2F_p}{3\pi\mu r^4 \psi_r} = a_n \quad (13)$$

it obtains this form

$$-\frac{dh}{dt} = h^3 \left(a_n + \frac{\omega^2}{20\nu} \right) \quad (14)$$

In a case $\omega = 0$ the solution of Eq. (14) gives result

$$\frac{1}{h^2} - \frac{1}{h_1^2} = 2a_n t_0 \quad (15)$$

where h_1 and h are magnitudes of the slit width at initial and any moments of time $t=0$ and $t=t_0$, respectively.

Accepting $\frac{1}{h_1^2} \ll \frac{1}{h_2^2}$ where h_2 is a final moment of time t_0 , and solving Eq. (15) with respect to t_0 we will have

$$t_0 = \frac{1}{2a_n h_2^2} \quad (16)$$

It follows from Eq. (15)

$$h = \frac{h_1}{\sqrt{1 + 2a_n h_1^2 t}} \quad (17)$$

For the case $\omega = 0$ Eqs. (16) and (17) may be rearranged into more convenient for practical application form using Eqs. (11) and (12) and some simplifications [5]. It leads to the following result

$$t_0 = \frac{3\pi\mu D l_0^3}{4F_p h_2^2} \quad (18)$$

and

$$h = \sqrt{\frac{3\pi\mu D l_0^3}{4F_p t}} \quad (19)$$

here $D = r_1 + r_2$ is rated diameter of the contact surface; $l_0 = r_2 - r_1$ is width of it.

Let us compute by formula (18) time t_0 from the moment of slit closure start to the moment corresponding definite position of the ring at the distance h_2 from the ring to the contact surface. Assume external radius of contact

surface $r_1 = 51.5$ mm, internal radius $r_2 = 48.5$ mm, initial width of the slit $h_1 = 10$ μm , external force $F_e = 100$ N (it equals to the pressure force F_p), dynamic viscosity of the liquid $\mu = 0.060$ m²/s. According to these data rated diameter of the ring $D = 51.5 + 48.5 = 100.0$ mm, the width of the ring $l_0 = 51.5 - 48.5 = 3.0$ mm. Results of the computations from 6 magnitudes of distance h_2 are given in the Table.

Table
Example of computation by equation (18) results

No	Distance h_2 , μm	Time t_0 , s
1	5.0	0.153
2	4.0	0.238
3	3.0	0.424
4	2.0	0.954
5	1.0	3.82
6	0.5	15.26

It is evident from the results of the computations, that for indicated conditions time required to reach dry contact between surfaces increases rapidly while width of the slit reduces up to the distance of few micrometers. $t_0 - h_2^m$ relationship carries power type character with $m = -2$, what is evident from the formula (18).

A tangential stress in the laminar flow of viscous liquid may be expressed as

$$\tau_\phi = \mu \frac{v_\phi}{h} = \mu \frac{\omega r}{h} \quad (20)$$

Integrating it along the surface of the ring we will have braking torque

$$T = \frac{\pi}{2} \mu (r_2^4 - r_1^4) \frac{\omega}{h} \quad (21)$$

When the ring is subjected to driving external torque T_e its motion will be described by equation

$$\frac{d\omega}{dt} = \frac{T_e}{J_r} - b \frac{\omega}{h} \quad (22)$$

here $b = \frac{\pi}{2} \mu \frac{r_2^4 - r_1^4}{J_r}$, where J_r is inertial moment of the ring with respect to axis Z.

Eqs. (14) and (22) are non-linear, the solution of their compound system may give $h - t$ and $\omega - t$ relationships. It is difficult to obtain a strict solution.

In the first approach let us assume $T_e = 0$. For an approximate solution expression (17) of h may be used in (22). Then

$$\omega = \omega_0 e^{-\alpha_n t} \quad (23)$$

where $\alpha_n = \frac{2}{3} \frac{b}{h_2}$, ω_0 is initial angular velocity of the mobile element of friction couple.

Applying Eq. (23) to Eq. (14) and integrating the

obtained differential equation instead of (15) we will have

$$\frac{1}{h^2} - \frac{1}{h_1^2} = 2a_n t + \frac{\omega_0^2}{20\nu\alpha_n} \quad (24)$$

Term $e^{-2\alpha_n t}$ was neglected, assuming it to be much smaller than 1. Denoting the term

$$h_\omega = \frac{\sqrt{20\nu\alpha_n}}{\omega_0} \quad (25)$$

we may rewrite the equation in the following way

$$2a_n t = \frac{1}{h^2} - \frac{1}{h_1^2} - \frac{1}{h_\omega^2} \quad (26)$$

Parameter h_ω has the length dimension. It may be imagined as an imaginary addition width of the slit moved by the mobile element due to the action of centrifugal forces. If $h \ll h_1$, term $\frac{1}{h_\omega^2}$ in Eq. (26) may be neglected and the influence of the centrifugal force on time of the mobile element approach to the immobile surface may be considered insignificant.

Assume that $r_2 = 50$ mm, $r_1 = 10$ mm, $r_2 = 10$ μ m, $\nu = 20$ cSt, $\rho = 900$ kg/m³, $m = 1$ kg, $\omega_0 = 105$ rad/s, that gives

$$\begin{aligned} h_\omega &= \frac{r_2 \nu}{\omega_0} \sqrt{\frac{40\pi\rho}{3h_2 m}} = \\ &= \frac{0.05 \cdot 20 \cdot 10^{-6}}{105} \sqrt{\frac{40 \cdot \pi \cdot 900}{3 \cdot 10 \cdot 10^{-6}}} = 580 \cdot 10^{-6} \text{ m} \end{aligned}$$

It is much greater h_2 . It shows that solution (17) may be considered sufficiently precise.

If external braking torque T_e is variable, the solution of equations set (14) and (22) obtains the other form. Function $T_e = f(t)$ should be known when analyzing the ring motion. To overcome this difficulty we suggest to start computations with a description of the dependence. For that reason assume gradual deceleration of the ring described by relationship $\omega = \omega_0 - \zeta_s \cdot t$, where $\zeta_s = \omega_0/t_s$ is constant computed from rotation speed ω_0 at the initial moment of time ($t = 0$) and t_s is full stop time. Applying this ω expression to (22) and considering that h may be found from Eq. (17) the torque may be finally expressed from equation

$$\frac{T_e}{J_0 \omega_0} = \frac{b}{h_1} \left(1 - \frac{t}{t_s}\right) \sqrt{1 + \left(\frac{h_1}{h_2}\right)^2 \frac{t}{t_s} - \frac{1}{t_s}} \quad (27)$$

Thus torque T_e is function of time, reaching the maximal magnitude at the moment of time

$$t_m = \frac{1}{3} \left(t_s - 2t_n \left(\frac{h_1}{h_2} \right)^2 \right) \cong \frac{1}{3} t_s \quad (28)$$

The torque corresponding that time moment is

$$\begin{aligned} T_{emax} &\cong \frac{2}{3} J_0 \omega_0 \frac{b}{h_1} \sqrt{1 + \left(\frac{h_1}{h_2}\right)^2 \frac{t_s}{3t_n} - \frac{1}{t_s}} \cong \\ &\cong \frac{2}{3} J_0 \omega_0 \frac{b}{h_2} \sqrt{\frac{t_s}{3t_n} - \frac{1}{t_s}} \quad (29) \end{aligned}$$

For the enumerated above magnitudes of parameters and $h_1 = 100$ μ m $T_{emax} = 0.290$ Nm.

It should be mentioned here that friction couple slit closure, while changes regime of hydraulic machine, is investigated not sufficiently. Few known works deal mostly with slits of curved [18], not of flat shape, therefore solutions of them do not suit for investigated by us and quite often met in hydraulic machines flat type friction couples. We hope that our research results will be useful for improvement resource parameters of hydraulic machines.

7. Conclusions

1. Pauses in hydraulic machine work have a great impact on the resource of the machine.
2. Rotation of one element of a friction couple with respect to another has no influence on a slit closure process after stopping a hydraulic machine.
3. Hydraulic machine resource depends on the number of its stops and duration of pauses.

References

1. **Bashta, T.M., Rudnev, S.S.** et al. Hydraulics, Hydraulic Machines and Power Drives. -Moscow: Machine Manufacturing, 1983.-423p. (in Russian).
2. **Bashta, T.M.** Hydraulics in Manufacturing of Machines. Handbook. -Moscow: Machine Manufacturing, 1971.-p.91-95 (in Russian).
3. **Sveshnikov, V.K., Usov, A.A.** Hydraulic Power Drives in Machines. -Moscow: Machine Manufacturing, 1988. -512p. (in Russian).
4. **Zdankus, N., Ziedelis, S.**, et al. Development and study of speeded up resource testing of swash plate type hydraulic piston motors. -Report of scientific research.-Kaunas: Kaunas Polytechnic Institute, 1988. -133p. (in Russian).
5. **Zdankus, N.** Pressing fluid out of a slit between the approaching surfaces. Sanitary engineering and hydraulics. -Ministry of culture and education of Lithuania. -Vilnius: Mokslas, 1992. p.74-81 (in Lithuanian).
6. **Ziedelis, S., Zdankus, N.**, et al. Method for Speeded up Resource Testing of Axial-Piston Hydro-Motors. Description of USSR invention No 1679073. Moscow, 1991.-3p. (in Russian).
7. **Ziedelis, S., Zdankus, N.**, et al. Stand for Resource Testing of Volumetric Hydraulic Machines. Description of USSR invention No 1483123. -Moscow, 1989. -4p. (in Russian).
8. **Bordag, L.A., Chekhetiani, O.G.** et al. Interaction of a rotational and an axial flow in small geometries of a Taylor-Couette problem. -Journal of Fluids and Structures, v.20, is.5, July 2005, p.621-641.
9. **Valiunas, K., Staponkus, V.** Investigation of pipe di-

- ameter change to pulsation of liquid flow pressure. -Mechanika technologija. -Kaunas: Technologija, 2006, v.XXXIV, p.114-120.
10. **Kargaudas, V., Zmuida, M.** Forced vibrations of two plates in a fluid and limit eigenmodes. -Mechanika. -Kaunas: Technologija, 2008. Nr.2(70), p.27-31.
 11. **Zdankus, N.** Regular pulsations of pressure in hydraulic power drives. -Mechanika. -Kaunas: Technologija, 1996, Nr.(4), p.38-41 (in Lithuanian).
 12. **Vladimirov, V.A., Yudovich, V.I.** et al. On wortex flow in a gap between two parallel plates. -Matematicheskie metody i vychislitelnye experimenty 13(2), p.27-37.
 13. **Betiaev, S.K.** Formation of a jet in case of non-stationary flow of a perfect fluid from a slit. -Journal of Applied Mathematics and Mechanics, 1981, v.45, is.6, p.778-784.
 14. **Handbook of Tribotechniques.** V. 2. Lubricants, Lubrication Techniques, Supports of Slid and Fluctuation. Ed. By M. Chebda and A.V.Chychnadze. -Moscow: Machine Manufacturing, 1990, p.240-257 (in Russian).
 15. **Juzenas, K., Juzenas, E.** Influence of oil tribologic properties on vibration level of low power rotory machines. -Mechanika technologija. -Kaunas: Technologija, 2006, v.XXXIV, p.56-61.
 16. **The handbook of fluid dynamics.** Ed. By Richard W. Johnson. -CRC PRESS Springer, 2000, p.48-1 – 48.11.
 17. **Brazas, T., Zdankus, N.** Adjustment of turbine's capacity to river flow regime. -Proceedings of Int. Conf. "Mechanika-2004". -Kaunas: Technologija, 2004, p.460-465.
 18. **Deheri, G.M., Abhangi, N.D.** Magnetic fluid based squeeze film between curved rough circular plates. -Mechanika. -Kaunas: Technologija, 2008, Nr.4(72), p.34-40.

N. Ždankus, V. Kargaudas

HIDRAULINĖS MAŠINOS DĖVĖJIMOSI VALDYMAS DARBO REŽIMU

Резюме

Straipsnyje nagrinėjami hidraulinių mašinų dėvėjimosi ypatumai. Aptartas trinties mazgų dilimo mechanizmas, jo tyrimo metodai. Įrodyta, kad mašiną sustabdžius skystis išspaudžiamas iš trinties mazguose esančių plyšelių ir, susilietus jų elementams, vyksta kontaktuojančių paviršių erozija.

Išvestos formulės skaičiuoti kritiniam laikui, per kurį trinties mazgo elementai susiliečia. Aprašytas spartesnis metodas hidraulinių mašinų resursui tirti, bandomąją mašiną dažnai paleidžiant ir stabdant, darant pauzes, virši-

jančias kritinį laiką. Hidraulinių mašinų resursui pailginti siūloma jas stabdyti kiek įmanoma rečiau, o pauzes, kai galima, daryti trumpesnes už kritinį laiką.

N. Zdankus, V. Kargaudas

HYDRAULIC MACHINE WEAR CONTROL BY WORKING REGIME

Summary

Peculiarities of hydraulic machine wear are analyzed in this paper. Mechanism of friction couples erosion and its research methods are described. It is stated that having stopped the machine the liquid is squeezed from slits in friction couples and when their elements come into contact the erosion of their surfaces occurs.

Formulas for computation of critical time required for the surfaces contact are derived and presented in the paper. A speeded up method for resource testing of hydraulic machines is described. Its essence lies in a frequent switching on and off the machine, keeping pauses slightly longer than critical time. To prolong the resource of a hydraulic machine the number of its stops should be reduced to minimum, pauses between stops and starts should be kept shorter than critical time.

Н. Жданкус, В. Каргаудас

УПРАВЛЕНИЕ ИЗНОСА ГИДРАВЛИЧЕСКОЙ МАШИНЫ РЕЖИМОМ ЕЁ РАБОТЫ

Резюме

В статье анализируются особенности износа гидравлических машин. Описан механизм износа узлов трения и методы его исследования. Утверждается, что при остановке гидравлической машины и вытеснении жидкости из зазоров, элементы узлов трения сближаются, контактируют и происходит эрозия их поверхности.

Представлены формулы для расчета критического времени, превышение которого ведет к эрозии рабочих поверхностей узлов трения. Описан метод ускоренных ресурсных испытаний, осуществляемый частым пуском и остановкой машины с выдержкой паузы превышающей критическое время. Для увеличения ресурса число их остановок и длительность пауз следует сокращать.

Received May 25, 2009

Accepted September 06, 2009