

Investigation of energy harvesting from high frequency cutting tool vibrations

V. Ostasevičius*, V. Jurėnas**, M. Žukauskas***

*Institute of Mechatronics, Kaunas University of Technology, Kaunas, LT – 44244, Lithuania,

E-mail: vytautas.ostasevicius@ktu.lt

**Institute of Mechatronics, Kaunas University of Technology, Kaunas, LT – 44244, Lithuania,

E-mail: vytautas.jurenas@ktu.lt

*** Institute of Mechatronics, Kaunas University of Technology, Kaunas, LT – 44244, Lithuania,

E-mail: man.zukauskas@gmail.com

crossref <http://dx.doi.org/10.5755/j01.mech.20.5.7902>

1. Introduction

Wireless sensors are conventionally powered by chemical batteries. The use of batteries not only leads to their costly replacement especially for sensors at inaccessible locations, but also causes pollution to the environment. The possibility to avoid replacing exhausted batteries is highly attractive for wireless networks (Wireless Sensor Networks) [1], in which the maintenance costs due to battery check and replacement are relevant. With the advances in integrated circuits, the size and power consumption of current electronics dramatically decreased. In the past few years, ambient energy harvesting as power supplies for small-scale electronics has evoked great research interest in various disciplines, including material science, mechanical, civil, and electrical engineering. Different energy sources existing in the environment around a system, such as sunlight, wind, and mechanical vibration, can be the options for energy harvesting. Among them, pervasive vibration sources are suitable for small-scale power generation of low-power electronics and thus have attracted more research attention. Current solutions for vibration-to-electricity transduction are mostly accomplished via electrostatic, electromagnetic or piezoelectric methods [2]. Various models, including analytical models, finite element models [3], [4] have been established to investigate energy harvesting capability of each method. No matter which principle was exploited, most of the previous research work focused on designing a linear vibration resonator, in which the maximum system performance is achieved at its resonant frequency. If the excitation frequency slightly shifts, the performance of the harvester can dramatically decrease. Since the majority of practical vibration sources are present in frequency-varying or random patterns, how to broaden the bandwidth of vibration energy harvesters becomes one of the most challenging issues before their practical deployment. Paper [5] presents a review of recent advances in broadband vibration energy harvesting. The state-of-the-art techniques in this field, covering resonant frequency tuning, multimodal energy harvesting, and nonlinear energy harvesting configurations, are summarized in detail with regard to their merits and applicability in different circumstances. Among available motion based harvesting techniques, piezoelectric transduction offers higher power densities [6] in comparison to electrostatic transduction (which also needs an initial polarization). Also, piezoelectric technologies are better suit-

ed than electromagnetic ones for MEMS implementation, because of the limitations in magnets miniaturization with current state-of-the-art micro fabrication [7]. Most harvesters in the literature operate at frequencies of less than 100 Hz, however, harvesting of energy from high frequency (1–10 kHz) vibrations, such as cutting tool motions [8], is desirable for powering wireless sensor nodes. This paper presents a high frequency driven, resonant, coupled vibration piezoelectric harvester that comprises circular piezoelectric bimorph. The manuscript consists of two main parts: numerical and experimental. It is organized as follows. In chapter 2, energy harvester type for machining process is identified. Chapter 3 is dedicated to experimental study of high frequency harvester. Chapter 4 is dedicated to dynamics simulation of energy harvester for practical realization of boring tool. Chapter 5 deals with the results of energy harvesters eigenfrequency broadening and practical application. The paper is finalized with concluding remarks.

2. Identification of energy harvester type for machining process

During machining process and passages of machine tools, vibrations of machine units occur. To use these vibrations is one of interesting ways of how to harness this ambient energy to power autonomous systems at the point of placement without the use of batteries or power supply cable. When a power harvesting system is integrated into

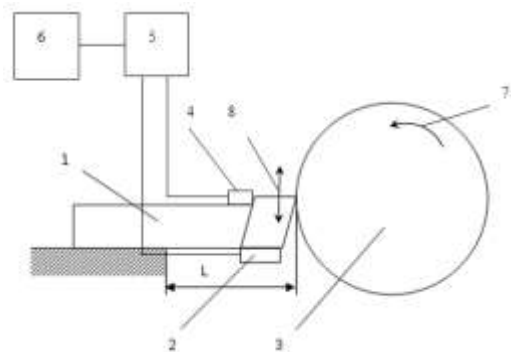

Fig. 1 Mounting scheme of power harvesting element on turning tool: 1 - turning tool; 2 - power harvesting element; 3 - work piece; 4 - accelerometer KD 91; 5 - oscilloscope Pico Scope 3424; 6 - PC; 7 - cutting direction; 8 - vibration direction of excited tool

a structure of cutting tool (Fig. 1), energy is removed in the form of electricity. Because energy is removed from the tools structure, some effect must be seen on its dynamics. The accelerometer KD91 was used to measure dynamic forces caused by vibrations.

When turning steel work piece tool vibrations measured by accelerometer KD 91 are shown in Fig. 2.

From Fig. 2 we see during cutting turning tool vibration frequencies are ~ 4-5 kHz. It means, that commercial piezoelectric cantilever type energy harvesters are not available due to very low resonant frequencies. For this

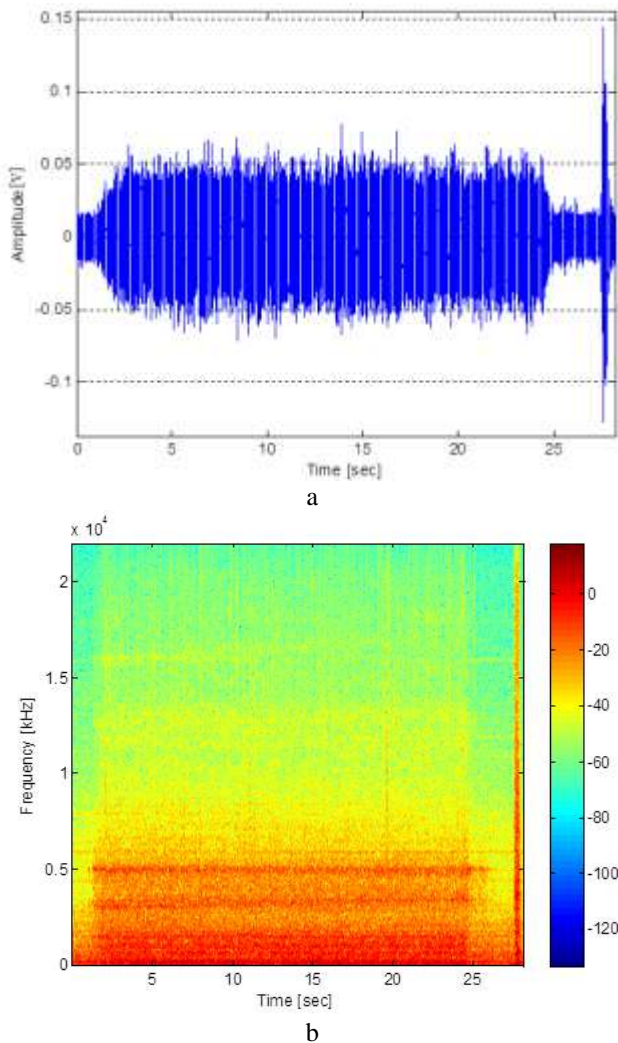

Fig. 2 Turning tool vibrations amplitudes (a) and tool vibration frequencies spectrogram (b)

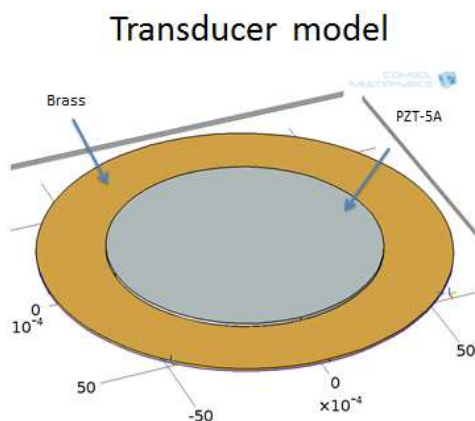

Fig. 3 Scheme of circular piezo transducer bimorph

reason high eigenfrequency circular piezoelectric bimorph composed from bronze disk and piezo element was chosen (Fig. 3).

3. Experimental study of high frequency harvester

When a power harvesting system is integrated into the vibrating structure, the force caused by vibration or a change in motion (acceleration) causes the mass to "squeeze" the piezoelectric material which produces an electrical charge that is proportional to the force exerted upon it and energy is removed in the form of electricity. An experiment was made to test the dynamics of piezo generator (Fig. 4).



Fig. 4 Experimental equipment: 1 - signal amplifier EPA-104; 2 - signal generator Agilent 33220A; 3 - multimeter Mastech MS8218; 4 - oscilloscope "PicoScope-3424"; 5 - laser displacement sensor LK-G82; 6 - controller LK-G3001PV; 7 - PC; 8 - power source; 9 - piezoelectric acoustic generator KBS - 15 DB - 4 A

Due to this analysis of the first mode of circular piezoelectric transducer was made exciting it with electro dynamical stand (Model 1072, RFT). The frequency response characteristics of five transducers were received and are presented in Fig. 5.

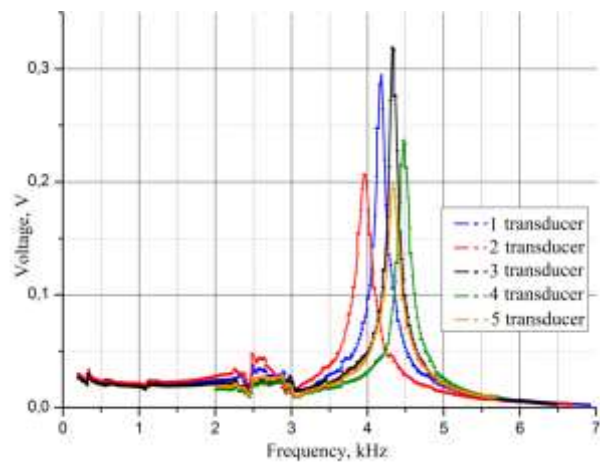

Fig. 5 Circular piezoelectric transducer bimorphs frequency response under acceleration of 1g

4. Dynamics simulation of energy harvester

From the presented result we can see that there is a significant energy transducers resonance frequencies distribution

at 3.9...4.5 kHz. As well as our objective is to show the possibility of frequency tuning of this piezoelectric transducer the mathematical model was developed. COMSOL multiphysics was chosen as a FEA tool. The piezoelectric transducer bimorphs model (Fig. 3) consists of brass disc (15 mm in diameter and 0.1 mm in height) and piezoelectric disk (10 mm in diameter and 0.1 mm in height). The fixture was simulated as a spring foundation with damping losses. Electrical boundaries were simulated as a 10 Mohm resistor load. The model was meshed using free triangular swept mesh for piezoelectric part and free tetrahedral elements for brass base.

Modes of vibration of transducer fixed along perimeter were calculated (Fig. 6). It is apparent, that vibration mode shapes are very similar to those of circular

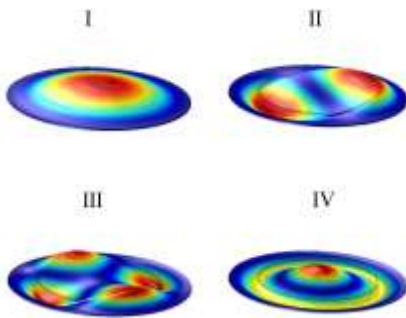

Fig. 6 Calculated vibration mode shapes of circular bimorph with fixed perimeter

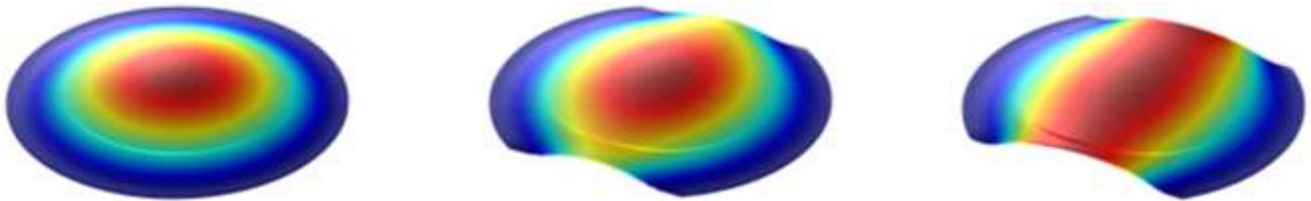

Fig. 7 Calculated vibration mode shapes of transducer: untrimmed – 4486 Hz (left), 1.25 mm trim – 3942 Hz (middle) and 2 mm trim – 3419 Hz (right)

membrane. The first (*I*) eigenfrequency (4486 Hz) closely agrees with the experimental values. The first mode shape of vibration is responsible for energy generation, whereas second (*II*) and third (*III*) mode shapes (9389 Hz and 14855 Hz) are deforming piezoelectric element in a symmetrical fashion, thus canceling out the generated charge. The fourth (*IV*) mode of vibration partially cancels out generated charges, its calculated eigenfrequency is 18201 Hz.

5. Broadening of energy harvester eigenfrequency

One of the proposed simple methods to tune the natural frequency of the transducer is to change the circular bimorph shape and constraints conditions by trimming two diametrically opposite sides (Fig. 7). The effect of trimming was compared with the circular bimorphs and the frequency sweep (Fig. 8) shows that trimming decreases the natural frequency without a noticeable decrease in generated voltage.

Another proposed way to tune the frequency is to trim the piezoelectric transducer's brass base in a triangular shape. Calculations show that the three side trimming lowers natural frequency without great losses in generated voltage as well. Comparing the two sides and three sides trimming it is apparent, that lower frequencies are achieved with three sides, this could be explained by lower structural stiffness.

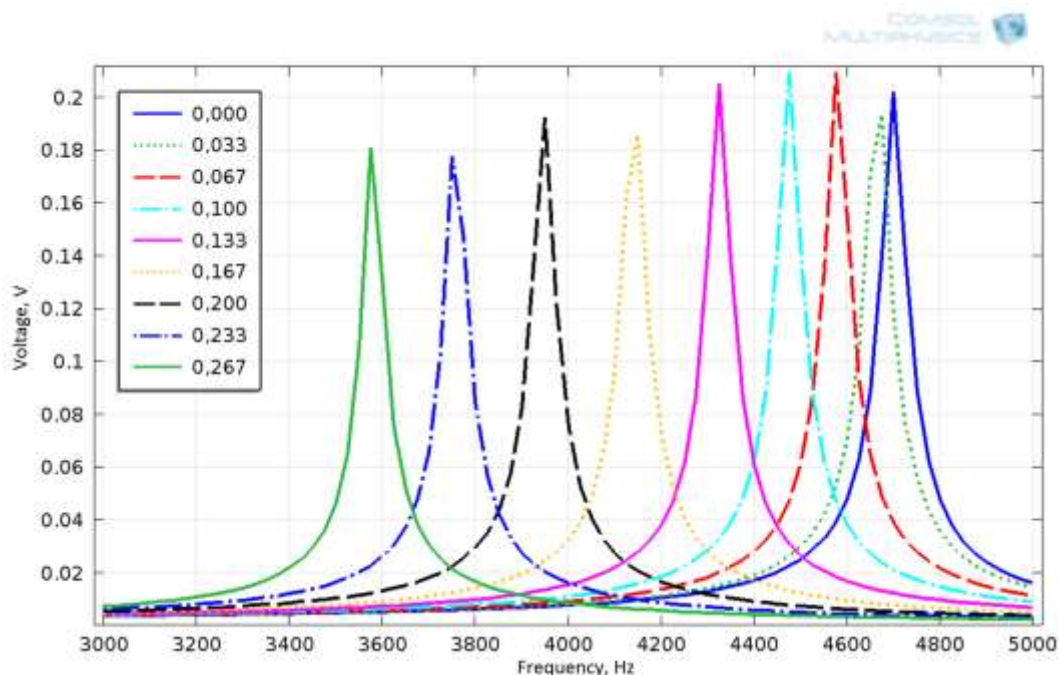

Fig. 8 Frequency sweeps of trimmed transducer (legend shows trim width in centimeters)

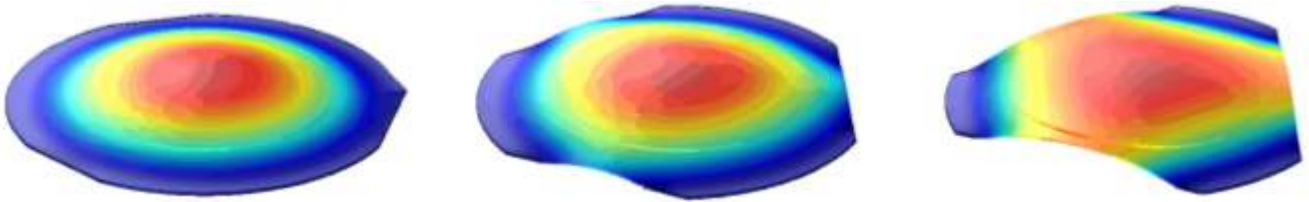

Fig. 9 Triangularly trimmed transducer's calculated vibration mode shapes: 0.25 mm trim – 4419 Hz (left), 1.00 mm trim – 3954 Hz (middle) and 2.00 mm trim – 3131 Hz (right)

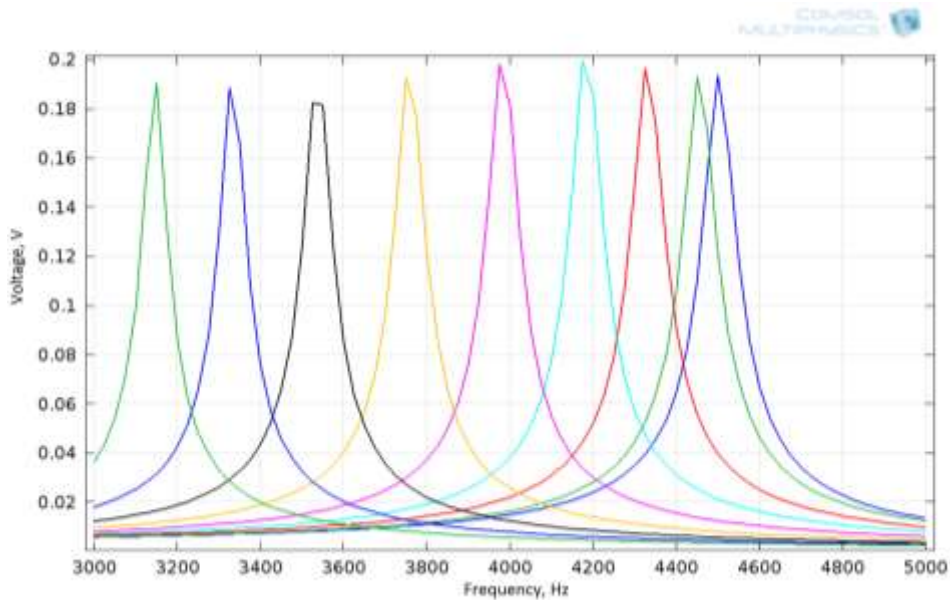

Fig. 10 Frequency sweep of triangularly trimmed transducer (rightmost curve corresponds to untrimmed transducer, each successive curve to left correspond to trim increase in a third of a millimeter)

The real challenge lies in ability to increase the natural frequency. The proposed method to achieve this effect was replacing circumferential fixture in to a smaller diameter one. The fixture was modeled as a spring foundation in a shape of a 0.5 mm width ring on a base of the transducer (Fig. 11). Mode frequency analysis shows that decreasing fixture radius at first increases the resonance frequency, but at around 0.7 r/R size ratio the frequency starts to decrease. Using this method to alter natural frequency produces situation where one natural frequency corresponds to two fixture sizes. Frequency sweep results (Fig. 12) reveal, that it is not practical to use fixture ratio smaller than 0.7, because voltage generation capacity becomes lower at similar natural frequencies. This effect can be explained by looking at mode shapes, when fixture size ratio is $r/R > 0.7$ most of the vibrational deformations are concentrated at the central part where the piezoelectric element is located. When fixture size becomes smaller the most deformed part becomes the periphery of the transducer.

When the excitation frequency is known a priori, the geometry and dimensions of a conventional linear harvester can be carefully selected to match its resonant frequency with the excitation frequency. Self-powered wireless sensor node of smart tool was developed using circular piezoelectric bimorph (Fig. 13) with the possibility to approach the frequency of piezoelectric bimorph to cutting tool frequency.

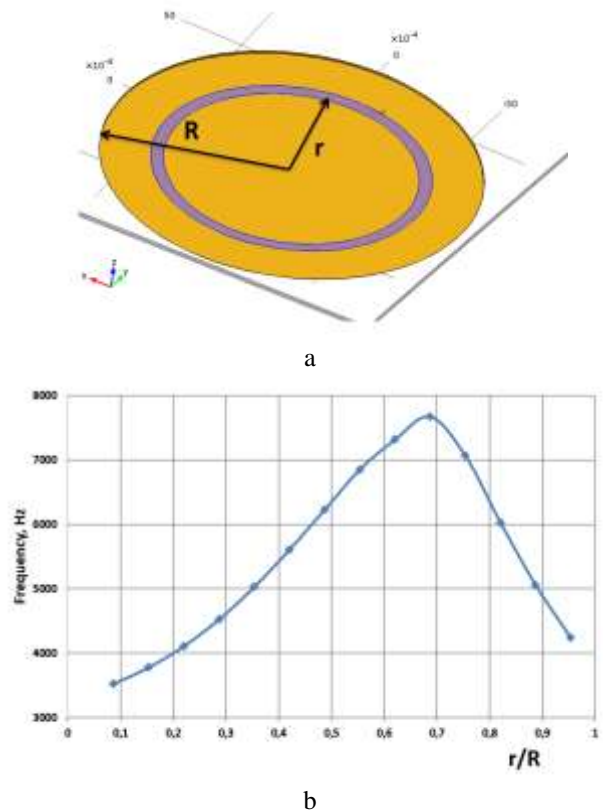

Fig. 11 Fixture scheme (a) and a graph of natural frequency dependence on fixture size ratio r/R (b)

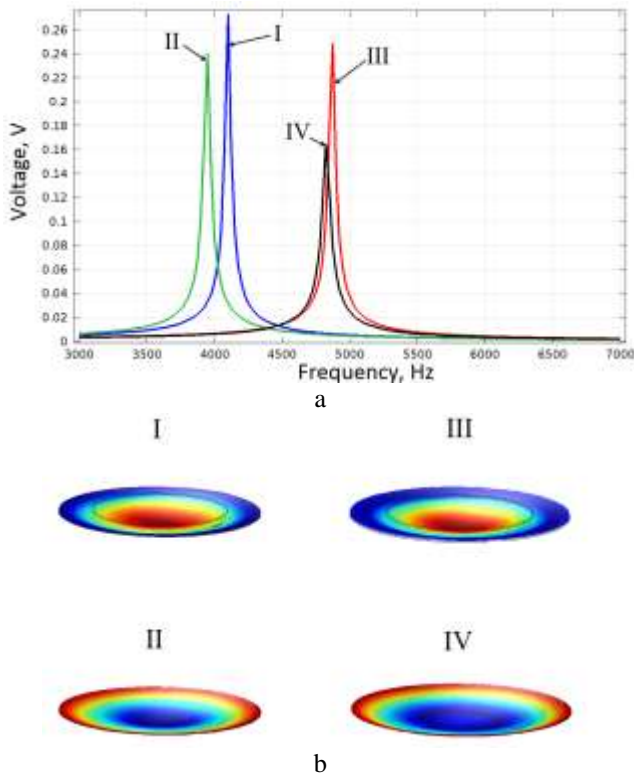

Fig.12 Frequency sweeps of several transducers with fixture size ratio $r/R > 0.7$ (I and III) and fixture size ratio $r/R < 0.7$ (II and IV) (a) and corresponding mode shapes (b)



Fig. 13 Self-powered wireless sensor node on turning tool

6. Conclusions

Piezoelectric converters are prominent choice for mechanical to electric energy conversion because the energy density is three times higher as compared to electrostatic and electromagnetics. High frequency driven, resonant, coupled vibration piezoelectric harvester that comprises circular piezoelectric bimorph is presented. Mathematical model was developed using COMSOL multiphysics as a FEA tool. Broadening of energy harvesters eigenfrequency is proposed. The resonance frequency of the piezoelectric transducer is dependent upon the configuration and constraints of circular piezoelectric bimorph. Simulation results show that trimming two diametrically opposite sides of circular piezoelectric bimorph decrease the natural frequency without a noticeable decrease in generated voltage. Comparing the two sides and three sides trimming it is apparent, that lower frequencies are achieved with three sides, this could be explained by lower structural stiffness. The real challenge lies in ability to increase the natural frequency by changing circumferential fixture in to a smaller diameter. Mode frequency analysis shows that de-

creasing fixture radius first of all the resonance increases, but at around of 0.7 r/R size ratio the frequency starts to decrease. Frequency sweep results reveal, that it is not practical to use fixture ratio smaller than 0.7, because voltage generation capacity becomes lower at similar natural frequencies. This effect can be explained by looking at mode shapes, when fixture size ratio is $r/R > 0.7$ most of the vibrational deformations are concentrated at the central part where the piezoelectric element is located. When fixture size becomes smaller the most deformed part becomes the periphery of the transducer. Self-powered wireless sensor node of smart tool was developed using circular piezoelectric bimorph with the possibility to approach its frequency to the cutting tool frequency

Acknowledgements

This research work was funded by EU Structural Funds project "In-Smart" (Nr. VP1-3.1-ŠMM-10-V-02-012), Ministry of Education and Science, Lithuania.

References

1. **Jornet, J.M.; Akyildiz, I.F.** 2012. Joint energy harvesting and communication analysis for perpetual wireless nanosensor networks in the terahertz band, *IEEE Trans. Nanotechnol.* 11: 570-580. <http://dx.doi.org/10.1109/TNANO.2012.2186313>.
2. **Anton, S.R.; Sodano, H.A.** 2007. A review of power harvesting using piezoelectric materials (2003–2006), *Smart Mater Struct* 16: R1-R21. <http://dx.doi.org/10.1088/0964-1726/16/3/R01>.
3. **De Marqui, C.Jr.; Erturk, A.; Inman, D.J.** 2009. An electromechanical finite element model for piezoelectric energy harvester plates, *J Sound Vib* 327: 9-25. <http://dx.doi.org/10.1016/j.jsv.2009.05.015>.
4. **Dauksevicius, R.; Kulvietis, G.; Ostasevicius, V.; Milasauskaite, I.** 2010. Finite element analysis of piezoelectric micro generator - towards optimal configuration, *EuroSensors XXIV Conference* 5: 1312-1315. <http://dx.doi.org/10.1016/j.proeng.2010.09.355>.
5. **Elvin, N.; Erturk, A.** 2013. *Advances in Energy Harvesting Methods*, Springer Science C Business Media, New York, 455p. <http://dx.doi.org/10.1007/978-1-4614-5705-3>.
6. **Roundy, S.; Wright, P.K.; Rabaey, J.** 2003. A study of low level vibrations as a power source for wireless sensor nodes, *Comput. Commun.* 26: 1131-1144. [http://dx.doi.org/10.1016/S0140-3664\(02\)00248-7](http://dx.doi.org/10.1016/S0140-3664(02)00248-7).
7. **Beeby, S.P.; Tudor, M.J.; White, N.** 2006. Energy harvesting vibration sources for microsystems applications, *Meas. Sci. Technol.* 17: R175-R195. <http://dx.doi.org/10.1088/0957-0233/17/12/R01>.
8. **Grazeviciute, J.; Skiedraite, I.; Ostasevicius, V.; Jurenas, V.; Bubulis, A.** 2006. Ultrasound application in turning process, *Proc. of the 6th international conference „Vibroengineering 2006“*: 152-154.

V. Ostaševičius, V. Jurėnas, M. Žukauskas

AUKŠTO DAŽNIO PJOVIMO ĮRANKIŲ VIRPESIŲ ENERGIJOS GENERATORIAUS TYRIMAI

Re z i u m ė

Nuolatinis bevielų jutiklių elektronikos energijos poreikių mažėjimas lėmė didelį susidomėjimą virpesių energijos panaudojimo savaimę energiją generuojančiai elektronikai tyrimų srityje. Šiuo metu daugelis virpesių energija paremtų energijos generatorių veikia kaip tiesiniai rezonatoriai, efektyviai dirbantys siaurame, jų rezonansiniam dažniui artimame, dažnių diapazone. Deja, daugeliu praktiškai pasitaikančių atvejų aplinkos vibracijos yra kintančio dažnio ar turinčios atsitiktinį energijos pasiskirstymą plačiame dažnių diapazone. Taigi, esminė problema siekiant pritaikyti šiuos energijos generatorius praktiškai pasitaikančiose situacijose yra jų darbinį dažnių ribų praplėtimas.

Šiame straipsnyje yra pristatomi aukšto dažnio diskinės formos piezoelektrinio energijos generatoriaus, modeliavimo rezultatai. Aukštų dažnių diapazone veikiantis generatorius pasirinktas nagrinėti dėl to, kad pjovimo proceso metu atsirandantys aukšto dažnio virpesiai galėtų būti panaudojami energijos generavimui. Pasiūlyti būdai leidžiantys valdyti diskinės formos piezoelektrinio generatoriaus rezonansinį dažnį keičiant jo formą, įtvirtinimo sąlygas. Pristatomas savaimę energiją generuojantis bevielų jutiklių modulis skirtas „išmaniajam“ pjovimo įrankiui.

V. Ostaševičius, V. Jurėnas, M. Žukauskas

INVESTIGATION OF ENERGY HARVESTING FROM HIGH FREQUENCY CUTTING TOOL VIBRATIONS

S u m m a r y

The continuous reduction in power consumption of wireless sensing electronics has led to immense research interests in vibration energy harvesting techniques for self-powered devices. Currently, most vibration-based energy harvesters are designed as linear resonators that only work efficiently with limited bandwidth near their resonant frequencies. Unfortunately, in the vast majority of practical scenarios, ambient vibrations are frequency-varying or totally random with energy distributed over a wide frequency range. Hence, increasing the bandwidth of vibration energy harvesters has become one of the most critical issues before these harvesters can be widely deployed in practice.

This paper presents the simulation results of high frequency harvester composed from circular piezoelectric bimorph. A high frequency piezoelectric generator is proposed, because that during material cutting excited high frequency vibrations could be useful for the excitation of circular piezoelectric transducer bimorphs. The broadband vibration energy harvesting possibility is achieved by changing circular plate shape and constraints conditions. Self-powered wireless sensor node is elaborated for smart cutting tools applications.

Keywords: vibration modes, energy harvesting, high frequency, piezoelectric bimorph.

Received Mai 13, 2014

Accepted October 01, 2014