

Application of photogrammetric method for height measurement instrumentation

V. Giniotis*, P. Petroškevičius**, J. Skeivalas***

*Vilnius Gediminas Technical University, Saulėtekio al. 11, 10223 Vilnius, Lithuania, E-mail: vg@ai.vgtu.lt

**Vilnius Gediminas Technical University, Saulėtekio al. 11, 10223 Vilnius, Lithuania, E-mail: pet-ras.petroskevicius@ap.vgtu.lt

***Vilnius Gediminas Technical University, Saulėtekio al. 11, 10223 Vilnius, Lithuania, E-mail: Jonas.Skeivalas@ap.vgtu.lt

1. Introduction

Levelling instruments are the same instruments as others used in length measurements, only the levelling being performed in vertical direction. Levelling instrument measures height according to the position of bars (strokes) on the levelling meter (staff) placed on an object and distance from the instrument's axis to the level meter. Optical digital levels used in geodesy are based on the data received from a bar code on a staff and processing it with an optical-electronic measuring instrument [1-3]. A view from the code meter is sent into photocell matrix (sensors array) where, at first, the distance to the meter is assessed by focusing optical image. Then, correlation coefficients of the bar code in the area of sensors are calculated. Coarse and precise correlation is assessed. Optical bar images projected into the photocells matrix or CCD camera are transferred into different voltage levels and, consequently, digital output. Visual aiming at the bar-meter is performed at first, and then the instrument operates automatically by focusing the lens to the target, transferring bar image into the matrix assessing the results (distance and height) by correlation analysis. Three main methods of image processing are used in the instruments: correlation method, geometrical method and phase method. Readings from the staff are taken along its longitudinal axis, distance to the staff and its height position are determined by readings of the translational transducer of the digital levelling instrument connected to the optical system during its pointing to the bars on the staff's surface. The height is determined according to the image of staff's bars transferred by optical system to photoelectric cells array of the instrument's unit and processed by microprocessor into height (in length units) values. Modern optical sensors and other technique are used in the instruments for data processing. Various codes of information modulation and means of evaluation are used in such instruments. Very good geometrical characteristics of staff must be ensured for this purpose, good contrast of the strokes (bars) on the surface is required to avoid ambiguity of the readings.

The processing to digital information is quite complex in those optical devices. For example, the strokes must be put on the whole length of the level staff. The height (length) of the staff reaches 4050 mm or 3000 mm. The bar code has about 2000 elements, the minimal width of which being 2.025 mm and varying up to about 10 mm. Manufacture and calibration of such devices require the application of high technologies, metrological methods and experience. The matrix of photocells in the reading instru-

ment consists of at least 256 elements, placed at the distance of 25 μm from each other. The accuracy of photocells placement also influences performance accuracy of the whole instrument. Information assessment performed by correlation analysis [4, 5] is also complicated and takes a significant amount of memory. For example, 50 000 coefficients of correlation are calculated in some levelling instruments. But in the systems of some instruments (for example, DiNi 10/20, etc.) only 30 cm length staff is enough for information evaluation. It means that it is very important to check the placement accuracy of strokes (bars) at full range of the meter to ensure high quality of height measurement by level instruments.

2. A simplified levelling meter

The most modern geodetic instruments are quite sophisticated digital instruments supplied with photoelectric sensor arrays and optical – electronic cameras that fix height values of the terrain according to the position of the levelling meter placed on it. The levelling meter is divided into the strokes of 2 cm length; other systems use 3 cm length strokes. A phase shift is ensured between the two types of strokes along all length of the meter. The third type of the strokes is used to get additional frequency information, and all these systems are used for the determination height and distance information. Processing differs in various levelling systems. The marks on levelling meters also are modified and consist from regular bars or coded strokes put on the meter's surface in specific order. The code applied also differs depending on manufacturer and the chosen system. The performance accuracy of these measuring equipment mostly depends on the accuracy of their strokes position.

A new structure of the levelling staff [6-8] using a simplified bar-code meter and the reading device operating without correlation value assessment was proposed. The main parts of the bar meter are two or three bars placed at calibrated distances. The position (height from the basis) is determined according optical axis of the device. Then the distance to the meter from the level (height) measuring instrument can be calculated using data from the device and assessing the calibrated distance between the strokes (bars) on the meter, and angle values between optical axis of the instrument and upper and lower strokes on the meter surface [7].

The new approach to the level instrument and bar meter construction gives a possibility to simplify the instrument itself and the bar meter especially [6-8]. Short

distance between the strokes on the meter gives an opportunity to calibrate it with high accuracy and use it as a reference measure for further calculations during measurements. Two or three bars on the staff will be marked more accurately than thousands of them used in current instruments. An error of placement equal to several microns can be achieved. Calculations presented in [6] show that in case of the distance between the bars $d = 0.2$ m, the standard deviation of calibration of this distance would be $\sigma_\alpha \approx 1''$ and it will be equal to $\sigma'_\alpha = d\sigma_c \approx 20 \mu\text{m}$ approximately. It is quite high accuracy for height measurement.

Analysis of mathematical expressions for measuring of the angles of sight line by pointing the levelling instrument to the points on two bars is presented in [6, 9]. Then the distance to the staff and the height from the line of sight to one of the strokes on the staff can be calculated using readings from the device.

3. Calibration methods of level meters

Accuracy calibration of levelling instruments and meters is performed in two steps: calibration of level meter and the instrument. Horizontal and vertical comparators are used for this purpose [10]. Linear position of the bars of the level meter is compared with that of the reference meter or length standard, usually, laser interferometer. Position of the bar is fixed by CCD camera, images are processed into

voltages and, subsequently, digital output. The procedure is similar to that used in the most digital levels. Using this information the distance and height are calculated by a microprocessor in the instrument determining the correlation value. This operation is not performed for calibration purposes because there is a need to determine only differences between the bars along their axis on the staff surface. This process now is performed using vertical or horizontal comparators and comparing the strokes (bars) on the meter with those on the reference (etalon) meter or with the readings from laser interferometer.

The photogrammetric method was proposed for the calibration of levelling meters [6]. The method proposed is based on comparing a photogrammetric view of the meter to be calibrated with the one saved in PC memory or taken from the reference (etalon) meter. An example of the calibration equipment of levelling meters applying a photogrammetric method is shown in Fig. 1. The views of those meters on a screen are shown in Fig. 2. Here numerical (old version) position of the staff bar is compared with the position of the coded bar on the screen of PC placing them side by side. Mutual shift of the two views also can be accomplished by computer means. Application software can be used for this purpose. Also supplementary linear scale is used in the screen to achieve a higher accuracy. Accuracy of the calibration process can be assessed by the calculation of standard deviations received during measurements and by correlation analysis.

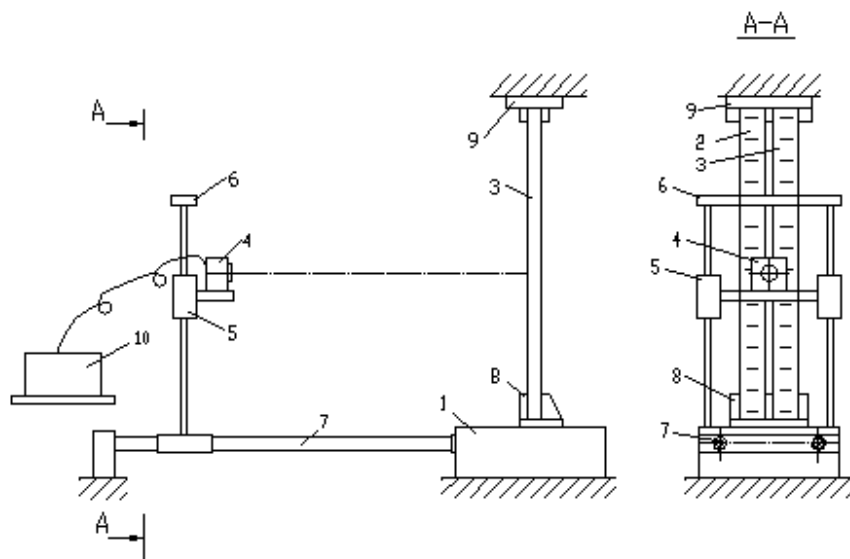

Fig. 1 Calibration equipment of levelling meters

The equipment (Fig. 1) consists of the base 1, meter to be calibrated 2, reference meter 3, digital camera 4, pallet 5, frame 6, slideways 7, lower support 8, upper support 9 and computer 10. The reference meter and the meter to be calibrated are fixed on the base 1, and digital camera 4 placed on the pallet 5 can be moved in horizontal direction on the slideways 7 and with the pallet 5 on the frame 6 – in vertical direction. Using these motions the required position of the camera's focus is established. The camera output is connected with the computer in control. The reference meter and the meter to be calibrated are taken by CCD camera simultaneously in the single screen placing their views beside each other. The camera is moved in horizontal and vertical directions for suitable exposition.

Two or three views of the staff at the beginning, middle and the end are to be taken at least. The most appropriate case is to cover all the length by single shot.

Image processing is performed by the assessment of values difference in length on digital photography of two meters – etalon (reference) and the meter under calibration. Their image is assessed in one view measuring position of the bars between themselves. General photogrammetric view of both meters is shown in Fig. 2. The view is supplied by optical reticulum sliding along the longitudinal scale. This is for measurement of the difference between linear position of the edges of the meters in comparison. This operation is performed in manual way using only a visual placement of reticulum on the edges of

the meters. Usually applied software (AutoCAD, etc.) can be used for this purpose. Readings are taken from the linear scale. Singular result of the error of the meter bar's position is

$$\Delta X_i = X_{mi} - X_{ei} \quad (1)$$

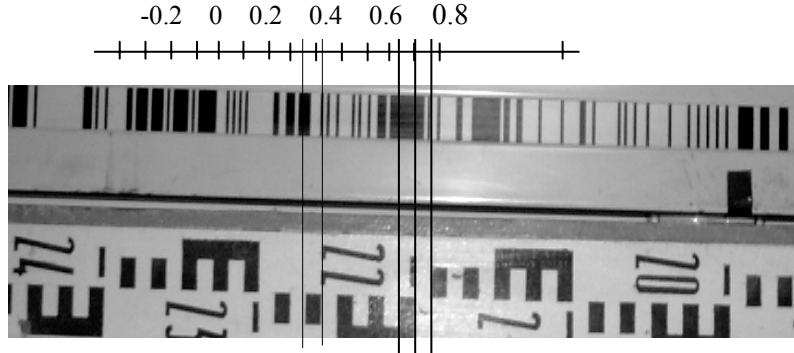

Fig. 2 View of the digital and bar-code meters under calibration

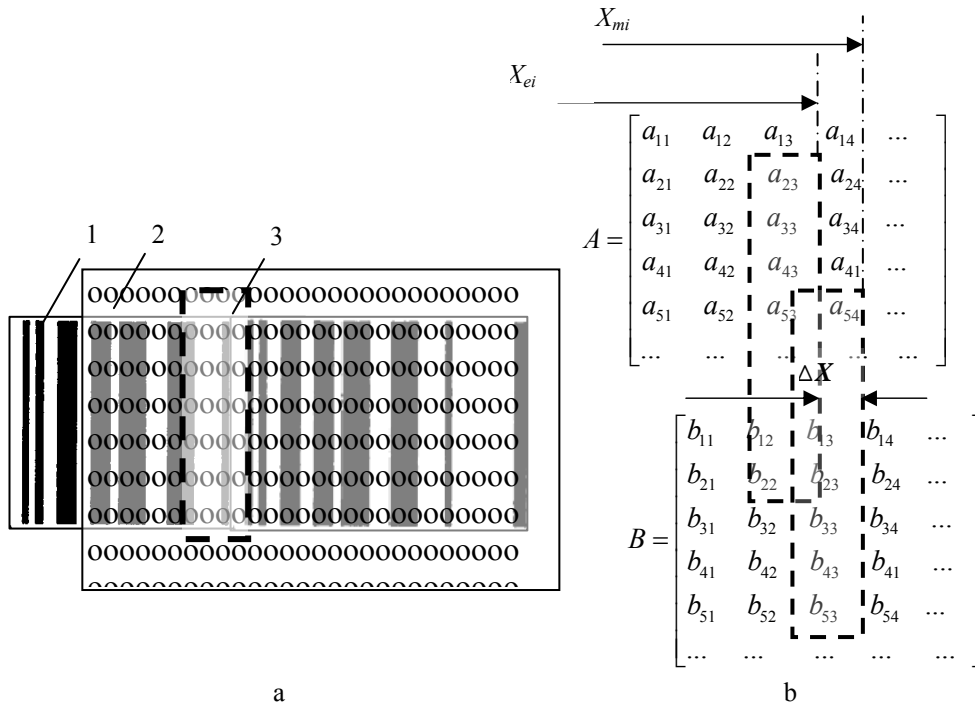

Fig. 3 Digital array of photosensors with the bars of meter on it (a) and digital output array from photosensors with analyzing window for subarrays selection (b)

All the length of the meter is calibrated selecting displacement pitch of the reticulum along all the length of the meters on computer screen.

Accurate comparison of the meters can be performed applying the correlation method. A better case is the comparison of the same type of meters, for example, both coded meters of the same producer. Signals from the photoelectric sensors (pixels) are output to PC making an array of numerical values from both meters at the same position. The calculations as in general photogrammetry are used, for example, a well known area-based method described in [11].

The difference is only in the aim of its application. In our case, it is the comparison of the position of bar edges on the tested meter. Processing of the images is completed in the same way as in the method above.

where X_{mi} is linear position of the bar's edge of the meter to be measured, X_{ei} is linear position of the bar edge of the reference meter. If there is a need and possibility, correction values for the etalon's bars position errors must be included.

Smaller subarrays from the both arrays are taken and the correlation factor is calculated using the formula [11].

$$r = \frac{\sum_{i=1}^m \sum_{j=1}^n [(A_{ij} - \bar{A})(B_{ij} - \bar{B})]}{\left\{ \left[\sum_{i=1}^m \sum_{j=1}^n (A_{ij} - \bar{A})^2 \right] \left[\sum_{i=1}^m \sum_{j=1}^n (B_{ij} - \bar{B})^2 \right] \right\}^{\frac{1}{2}}} \quad (2)$$

here: r is correlation coefficient; m and n are numbers of rows and columns in the digital matrix; A_{ij} is digital number from subarray A in the row i and in the column j ; \bar{A} is average of all digital numbers in subarray A , and \bar{B} is average of all digital numbers in subarray B . $i = 0, 1, 2, 3, \dots, m$; $j = 0, 1, 2, 3, \dots, n$.

The correlation coefficient is calculated from the subarrays that are selected by an analyzing window placed on the view of the meters. General diagram of photosensors (pixels) with the view of the coded bar of levelling meter and the analyzing window are shown in Fig. 3, a and b. Coded bars 1 of meter are placed on array 2 of CCD sensors which is covered by analyzing window 3 (Fig. 3, a). X_{mi} , X_{ei} is longitudinal position of the edge of analyzing window placed according to the same value of correlation coefficient of digital output array of reference and meter to be calibrated, ΔX is bias of bars edge position of meters in comparison (Fig. 3, b).

A digital output from the photosensors presented in the form of matrixes \mathbf{A} and \mathbf{B} , from the view of etalon meter and calibrated meter respectively, are shown in Fig. 3, b.

The error of displacement (differences between the positions of bars on the meters) is determined by the local correlation coefficient. Such operations are performed as follows:

- preliminary correlation coefficient is calculated at the beginning, middle and the end part of the meters using the formula (2);
- the subarray \mathbf{B} is shifted at the predetermined pitch Δ_t , the operation as described above is repeated;
- the first two operations are repeated in the investigation region $\pm k\Delta_t$, where $k = 1, 2, 3, \dots$ covering the zone of expected error of the meter's bars placement.

It is evident that total array of the numbers representing the position of the bars on the surface of the levels will be received from the array of sensors of CCD camera, converting voltage output into digital form.

The final result of calibration can be expressed by determination of the measurand

$$\delta x_i = k(\bar{x}'_{mi} - \bar{x}'_{ei}) \pm \frac{tS}{\sqrt{n}}; \mathcal{P}; \frac{I_1}{I_0} \quad (3)$$

where coefficient of the optical view's scale is $k = \frac{x_i}{x_{ei}}$,

where X_i and X_{ei} are the values of distances on the photo view and the true value, \bar{x}'_{mi} is mean value of longitudinal position of the edge of the meter under calibration, \bar{x}'_{ei} is mean value of longitudinal position of the edge of the reference meter, $\frac{tS}{\sqrt{n}}$ is uncertainty of measurement, t is

Student coefficient, S is evaluate of the standard deviation, n is number of measurements, \mathcal{P} is probability level, I_1 is information value after the calibration, I_0 is information value before the calibration. An information entropy assessment presented in Eq. (3) gives an efficient criteria to assess the quantity of measuring information in consideration [12]. More exact evaluation of the edges of the bars can be performed by using the feature-based digital image assessment technique. In case of a blurred image of the meters, additional statistical means must be taken for position determination of the bars. The values of the photogrammetric points of the image are assessed by evaluates of standard deviations S_x , S_y and

$$S_{xy} = \sum(x, y) - \frac{(\sum x_i)(\sum y_i)}{n} \quad (4)$$

Both coordinates x and y are necessary for better determination of the position of the bar's edges (linearity of the edge) as can be seen in Fig. 3. Linear regression equation $y = \alpha + \beta x$ can be used for this assessment as

well, where $\beta = \frac{dx}{dy}$ is the slope of the line, and parameter

α is a constant at value $X=0$. The same can be determined as

$$\beta = \frac{S_{xy}}{S_x^2}; \alpha = \frac{\sum y_i}{n} - \beta \frac{\sum x_i}{n}$$

Accordingly, the sample correlation coefficient can be calculated as

$$r = \frac{S_{xy}}{\sqrt{S_x^2 S_y^2}} \quad (5)$$

Such calculations as presented in [11] would be usefull for the determination of the points on the meter's bar edges, and their systematic error will be determined by changing the pitch Δ_t of a subarray sample selection.

By using the analyzing window on the search array of digital numbers, its position must be changed by steps at the chosen pitch Δ_t . Therefore, maximal value of correlation coefficients will be determined at some values $i\Delta_t$ of the meter's length, different from those on the etalon meter. This difference will be equal to the systematic error of the bars position along the whole length.

Advantages of the photogrammetric method of calibration are that there is no need to develop bulky and very expensive equipment for calibration. Such equipment takes much place and volume, is very expensive. Photogrammetric methods can be applied with minor expenses and using the cameras on the market. Cameras having 8-10 megapixels resolution can be applied successfully. The problem remains to achieve a higher accuracy as preliminary experiments show that till now possible application of this method is for calibration of meters of lower accuracy.

4. Conclusions

Preliminary experiments show a possibility to perform the calibration of levelling meters by using photogrammetric methods of its comparison. The processing of digital output array using an analyzing window is to be used.

An area based comparison method used for general purpose photogrammetry can be applied for calculating the correlation coefficients during shift of the images along each other and the systematic error of the meter under calibration is determined by the differences of length distance having equal values of correlation coefficient.

Acknowledgements

This work has been funded by Lithuanian State Science and Studies Foundation, Project No T-99/07.

References

1. **Ingensand, H.** The evolution of digital levelling techniques – limitations and new solutions, Geodesy Surveying in the Future. The Importance of Heights. -Proceedings.-Gavle, Sweden, M. Lilje, ed., 1999, p.59-68.
2. **Menzel, M.** The development of levels during the past 25 years, with special emphasis on the NI002 optical geodetic level and the DiNi[®] 11 digital level.-Geodesy and Surveying in the Future. The Importance of Heights. -Proceedings, M. Lilje, ed., 1999, p.85-93.
3. NA 2002. NA 3003, Technical Report, Digital Levels. -Leica Geosystems AG, Geodesy, CH-9435 Heerbrugg, (Switzerland), 1997.-15 p.
4. **Grattan, K.T.V., Skeivalas, J., Giniotis, V.** Development of 2D optical measurements.-Proceedings of the 17 IMEKO World Congress, 2003, p.1831-1833.
5. **Ingensand, H., Meissl, A.** Digital levels on the way to 3-D measurements.-Conference on Optical 3-D Measurement Techniques.-Wien: Technische Universitat, 1995, p.61-67.
6. **Skeivalas, J., Giniotis V.** Accuracy and performance analysis of digital levels. Optical Engineering, Vol. 44, No 2, 2005, p. 027007-1-6.
7. **Giniotis, V., Skeivalas, J.** The Level, Lithuanian Patent LT 4966 B, Int. Cl. G01C 5/02 / Vilnius Gediminas Technical University.-Vilnius: State Patent Office, 2002.-10p. (In Lithuanian).
8. **Giniotis, V., Petroškevičius, P., Skeivalas, J.** The Arrangement for Calibration of Levelling Meters. LT patent, Int. Cl. G01B 11/00, G01B 5/008, Nr. 5333.-Vilnius Gediminas Technical University, OB 2006.04.25, p.10. (In Lithuanian).
9. **Skeivalas, J.** An accuracy of determination of the covariation of random values.-Geodesy and Cartography 25, 1999, 4, p.156-158.
10. **Takalo, M. and Rouhiainen, H.** On Use of FGI System Calibration Comparator.- Finnish Geodetic Institute.-Paris, France, 2003.-28p.
11. Manual of Photogrammetry. Fifth edition. Editor J. Chris McGlone, American Society for Remote Sensing. -525p.
12. **Giniotis, V., Grattan, K.T.V., Rybokas, M. and Kulvietiene, R.** Uncertainty and indeterminacy of measurement data. -Measurement, 2004, 36/2, p.195-202.

V. Giniotis, P. Petroškevičius, J. Skeivalas

FOTOGRAMETRINIŲ METODŲ TAIKYMAS AUKŠČIO MATAVIMO PRIETAISŲ SRITYJE

Резюме

Straipsnyje analizuojamos aukščio matuoklių tikslumo įvertinimo priemonės ir niveliavimo matuoklių kalibravimo metodai. Nagrinėjamos naujos aukščio matavimo priemonės, kurios leidžia supaprastinti skaitmeninių nive-

liavimo prietaisų konstrukciją ir niveliavimo procesą. Aprašytas fotogrametrinis metodas niveliavimo matuoklių tikslumui kalibruoti naudojant CCD sensorius ir koreliacinę analizę skaitmeninei informacijai apdoroti. Nagrinėjama problema yra aktuali, kai reikia nustatyti tikslumą prietaisų, naudojamų mašinų stalams ir pačių mašinų aukščiui niveliuoti pramonės įmonėse, geodezijos darbuose ir statybose. Šie metodai gali būti taikomi ir mašinų dalių geometriniam parametrui, ilgiam ir kampams matuoti.

V. Giniotis, P. Petroškevičius, J. Skeivalas

APPLICATION OF PHOTOGRAMMETRIC METHOD FOR HEIGHT MEASUREMENT INSTRUMENTATION

Summary

The paper deals with the height measurement instrumentation and means and methods for an accuracy assessment and calibration of levelling meters. New approach to height measurements is reviewed permitting to simplify the construction of digital levelling instruments and the levelling process itself. A photogrammetric method for accuracy calibration of levelling meters is described using the CCD sensors and correlation analysis for digital information processing. A problem discussed is valid for accuracy determination of levelling meters which are used for levelling the machines' tables and the machines itself in the industry plant, in geodesy and building structure and can be applied for measurement of geometrical parameters of parts of the machines, length and angle standards.

В. Гиниотис, П. Петрошкявичюс, Й. Скейвалас

ПРИМЕНЕНИЕ ФОТОГРАММЕТРИЧЕСКИХ МЕТОДОВ В ОБЛАСТИ ПРИБОРОВ ИЗМЕРЕНИЯ ВЫСОТЫ

Резюме

В статье анализируются методы и средства для определения точности реек нивелиров. Рассматриваются новые средства измерения высоты, которые позволяют упростить конструкцию цифровых нивелиров и сам процесс нивелирования. Описан фотограмметрический метод калибрования точности нивелирных реек с применением CCD сенсоров и корреляционный анализ обработки цифровой информации. Анализируемая проблема является актуальной для определения точности нивелиров, применяемых для выставления рабочих столов машин на производственных предприятиях и самих машин, в геодезических работах и на строительстве. Метод также может быть применен для измерения геодезических параметров частей машин и узлов.

Received November 19, 2007

DOI: 10.5755/j02.mech.12154