

Research of complex rotary systems vibrocondition based on analysis of dynamical processes and spectrum of vibrations

E. Juzėnas*, R. Jonuřas**, K. Juzėnas***

*Kaunas University of Technology, Keřtućio 27, 44312 Kaunas, Lithuania, E-mail: ejuzenas@ktu.lt

**Kaunas University of Technology, Keřtućio 27, 44312 Kaunas, Lithuania, E-mail: remigijus.jonusas@ktu.lt

***Kaunas University of Technology, Keřtućio 27, 44312 Kaunas, Lithuania, E-mail: kjuzenas@ktu.lt

1. Introduction

Reliability and quality of rotary systems are known to depend on their vibration activity [1]. Typically, in complex rotary systems mechanical vibrations are generated by several rotors, clutches, gear drives, rolling or sliding bearings and other sources [2]. Degradation process emerging during exploitation of the systems is caused by various sources and is followed by increased vibration activity, temperature of various elements, changes of oil tribological properties and lower quality or quantity of production.

Therefore, the analysis of dynamical processes, modelling of various situations and analysis of vibrations are still essential tools for monitoring and controlling complex rotary machines. These tools enable researchers to foresee potentially harmful situations, evaluate the sources of vibrations, lower the influence of degradation processes and predict reliability of complex rotary systems.

2. Object of research

For the object of this research a complex technological machine GTT3 (Fig. 1) has been chosen. It consists of an electric motor (0.8 MW), a steam - fusion gas turbine - axial compressor, a centrifugal compressor and a mechanical reducer (Table 1). Its all three rotors (electric motor, turbine and centrifugal compressor) run on sliding bearings (hydrodynamic elliptical bearings). During the operation regular angular frequencies of the rotors are between their first and the second natural frequencies. The rotors run in hydrodynamic ellipsoidal bored-out bearings.

Table 1

Characteristics of the compressor

Characteristic	Electro-motor	Turbine – axial compressor	Centrifugal compressor
Nominal rotation, r/min	3000	5200	7500
First critical speed, r/min	1800	3110	3600
Mass of the rotor, kg	1490	2500	500

An especially urgent problem is to decrease vibrations of the rotor of centrifugal compressor with two impellers having blades mounted on it because it runs at the highest speed. To avoid unexpected breakdown situations and to predict possible failures the vibrations have been measured and numerically modelled. The experiments and

their results are discussed further. The dynamical model includes a rotor of the reducer with its supports.

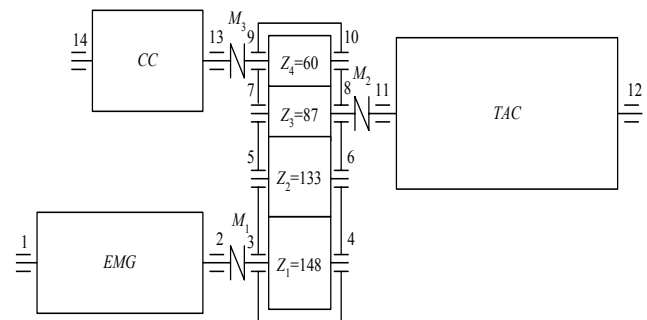

Fig. 1 Scheme of GTT3 compressor. EMG – electric motor-generator, CC – centrifugal compressor, TAC – turbine-axial compressor, 1, 2,... 14 – sliding bearings, M₁, M₂, M₃ – couplings between rotors, Z₁, Z₂, Z₃, Z₄ – teeth numbers of reducer gearwheels

3. Experimental research

The analysis of experimentally measured spectral characteristics of the rotor supports vibrations has shown that there are low frequency components generated by unbalances, anisotropy of the rotor structure, deviations of rotor centering, etc. High frequency components are also generated by deviations of the positioning of reducer gearwheel. These deviations are caused by the defects of gears incurred during manufacture and assembly. Therefore, periodic measurements of vibrations have been performed in a quite wide range of frequencies (0 - 7500 Hz) aiming to collect more comprehensive data.

Table 2

Characteristics of vibrations

Conditions of measurements		Mean square value of vibrations speed V_{RMS} , mm/s	Allowable values of V_{RMS} , mm/s (ISO 10816-1)	
Point of measurement	Condition of bearing		Zone B	Zone C
9	normal	7.2 (Fig.2, a)	4.5	11.2
9	gap is increased	11.6 (Fig.2, b)	4.5	11.2
13	normal	2.6 (Fig.3, a)	4.5	11.2
13	gap is increased	6.3 (Fig.3, b)	4.5	11.2

Measured values of V_{RMS} (mean square value of vibrations speed) and allowable values of this parameter are presented in Table 2. Here Zone B and Zone C present

acceptable conditions of exploitation and conditions when maintenance of the machine is needed.

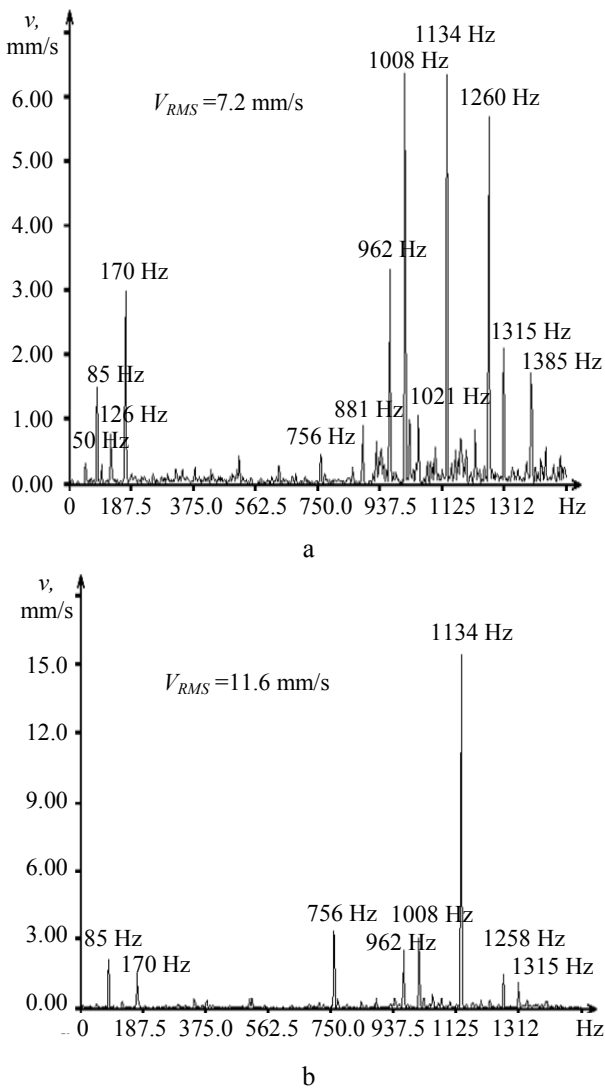

Fig. 2 Spectrum of the reducer bearing vibrations measured in vertical direction: a - exploitation conditions are in a regular range; b - gap in the bearing is increased

The spectral analysis of vibrations of the centrifugal compressor and reducer supports next to coupling M_3 is presented as typical for this machine. Two cases are analysed: when the gap in a compressor sliding bearing is normal (0.2 - 0.3 mm, Fig. 2, a and Fig. 3, a) and when the gap is increased (0.5 - 0.7 mm, Fig. 2, b and Fig. 3, b). This analysis shows that acceptable conditions of the machine exploitation are reached only when the gap in the bearing is normal. Here, spectral components of 50 Hz, 85 Hz and 126 Hz show the rotary speed of electric motor, turbine - axial compressor and centrifugal compressor. Amplitudes of these components indicate the influence of either rotor unbalances or deviations of rotor centering. The component of 170 Hz presents a second harmonic of the turbine - axial compressor rotary frequency caused by anisotropy of the rotor structure. High frequency components of 1007 Hz, 1134 Hz and 1260 Hz are caused by the defects of the reducer gearwheels and their assembling.

It has to be mentioned that the changes of bearing gaps and other parameters of certain machine elements influence vibration activity of other elements (reducer,

turbine and electro motor) greatly. For example, in case when the gap in the compressor bearing is increased, the vibrations of the reducer bearing next to coupling M_3 increase hugely and V_{RMS} reaches the value of 11.6 mm/s. The component of 1134 Hz is specifically sensitive to the operating conditions of the reducer. An increase in radial gap in a sliding bearing of the reducer causes an increase in this spectrum component amplitude by approximately 2.5 times (Fig. 2, b). The analysis shows that such increase in this vibrations harmonic is caused by the changes in gearing conditions of reducers herringbone gearwheels because of an increase in radial gaps in the bearings. In such a case the machine can not be operated and should be stopped for maintenance.

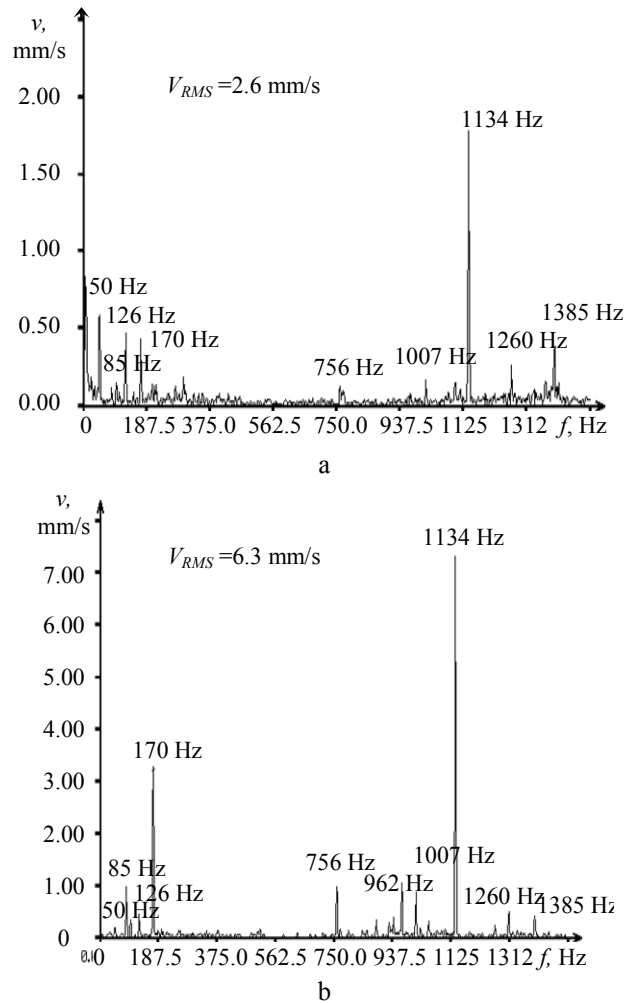

Fig. 3 Spectrum of the centrifugal compressor's bearing vibrations measured in vertical direction: a - exploitation conditions are in a regular range; b - gap in the bearing is increased

However, these data obtained experimentally when measuring the vibrations of bearing supports do not always suffice. For example, for comprehensive evaluation of rotary machine dynamic conditions it is also important to know the situation of rotor middle points (between supports) vibrations, because frequently there are the peak amplitudes of vibrations there. Often it is impossible (alike in our case) to measure those vibrations experimentally, because the access to the inner elements is impossible during machine operation. Therefore, the experimental results are not always sufficient enough for designing and tuning

mechatronic monitoring and control systems. Such information can be obtained only by applying dynamical modelling [1, 3].

4. Dynamical model

The dynamical equation of the compressor rotor has been set up applying the method of finite elements (FEM) [4, 5]. The rotor of centrifugal compressor GTT3 and the adjacent gear shaft of the reducer are divided into 18 elements and analysed as a system of flexible rotors (Fig. 4). Each element has 4 degrees of freedom.

The equation characterizing forced vibrations of the modelled rotor [5] is

$$(\mathbf{M} + \mathbf{M}')\ddot{\mathbf{U}} + (\omega\mathbf{G} + \mathbf{C})\dot{\mathbf{U}} + \mathbf{K}\mathbf{U} = \mathbf{F} \quad (1)$$

here \mathbf{M} is the matrix of rotor masses; \mathbf{M}' is the matrix of masses characterizing rotation of the rotor cross-sections around the axes of a coordinate system; \mathbf{G} is gyroscopic matrix; \mathbf{C} is damping matrix; \mathbf{K} is stiffness matrix; \mathbf{U} is the matrix of rotor elements displacements; \mathbf{F} is the matrix of forces affecting the rotor; ω is angular velocity of the rotor. \mathbf{M} matrix represents the masses of beam elements and matrix \mathbf{M}' allows evaluating the rotation of their cross-sections.

The structure of matrix \mathbf{F} depends on the type of exciting forces. Usually those forces are caused by unbalances, anisotropy and deformations of certain rotors and their elements. The affecting forces can also be created by other sources of excitation: by hydrodynamic processes in machine sliding bearings, defects in rotors centering and assemblage, defects of gearwheels and their assemblage, etc. The detailed descriptions of a dynamical model and the structure of matrixes have been presented in previous publications [6].

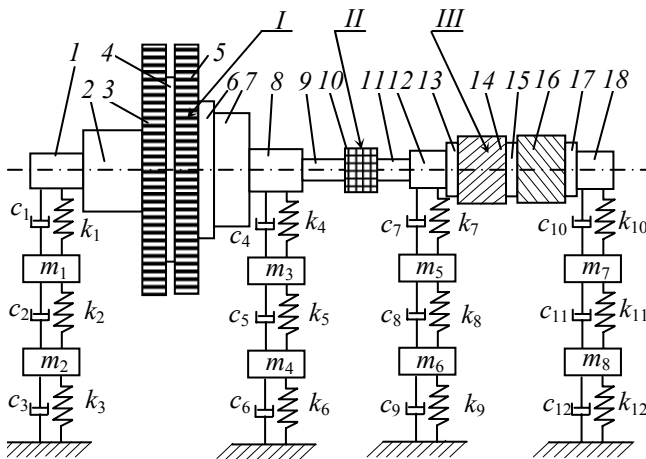

Fig. 4 Dynamic model of centrifugal compressor and reducer rotors: I – centrifugal compressor rotor, II – coupling, III – gear shaft with herringbone gears, m_i , k_i , c_i – masses, stiffness and damping coefficients of rotor supports, respectively 1 – 18 structural elements of the rotors

Modeling of rotors dynamics yields the amplitude-frequency characteristics of various elements. It allows to evaluate dynamics and conditions of rotor elements

which, due to the machine design, can not be measured or monitored experimentally, or such monitoring is very complicated (e.g. vibrations monitoring of the central part of the rotor and other internal elements that are not accessible during machines exploitation).

The amplitude-frequency characteristic of the compressor rotor central element (4th element) and the reducer rotor central element (15th element) are presented in Fig. 5, a and b. It has been assumed that vibrations are generated by rotor unbalances.

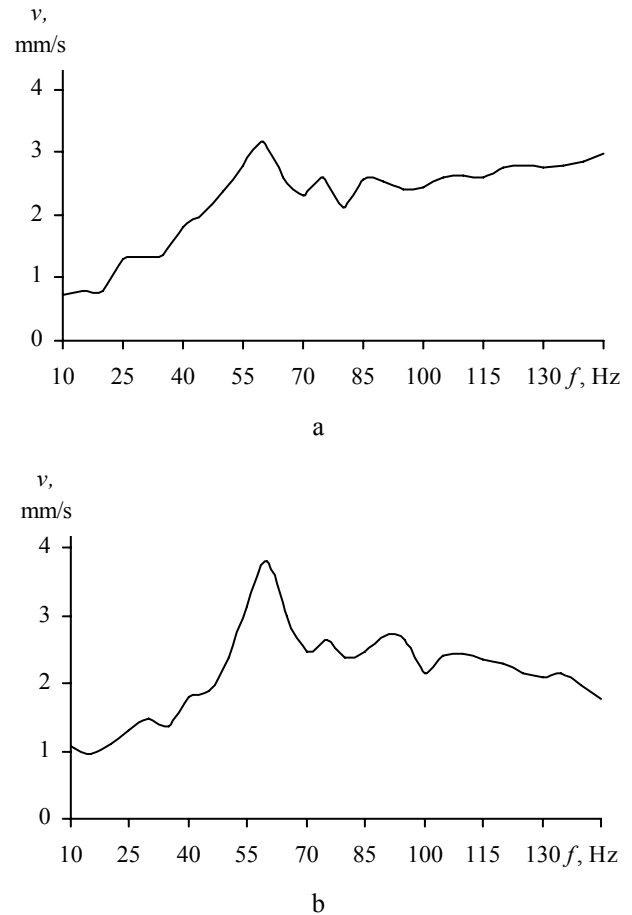

Fig. 5 Amplitude - frequency characteristics: a - of the 4th element vibrations; b - of the 15th element vibrations

These graphs give the information about the dynamic condition of certain rotor elements and can be obtained for any element, described in the numerical model. The peaks of presented curves show harmonics of the first critical speed.

Such modelling is also used to determine the sources of vibration components measured experimentally. Therefore, such research helps to find critical frequencies determining the influences of various defects and their critical values, etc. It helps to predict both the machine vibration activity under certain conditions and reliability of this machine during its exploitation.

Research on vibration activity of complex rotary systems, based on the analysis of dynamic processes and the spectrum of vibrations side by side with modelling of dynamical situations and the data of other parameters monitoring allows a thorough evaluation of machine dynamical condition and predict reliability of such equipment during its exploitation.

5. Main results and conclusions

The analysis of experimental results makes it possible to evaluate the vibrations level for different harmonics and diagnose their sources, however it is not enough for the comprehensive analysis of machine dynamic condition.

Modelling of dynamic processes in rotary systems applying FEM gives the information about the condition of various rotors elements (including those whose vibrations can not be measured experimentally). Therefore, it presents important experimental information which cannot be obtained experimentally.

References

1. **Juzenas, E., Juzenas, K., Jonusas, R., Barzdaitis, V.** Analysis of flexible rotor dynamic model adequacy applying FEM and various methods of damping evaluation.- DSTA 2005- 8th Conference on Dynamical Systems: Theory and Applications, Lodz: 2005, v.2, p.687-694.
2. **Spruogis, B., Turla, V., Jakštas, A.** Investigation of radial misalignment influence on dynamics of precise rotor system. -Mechanika. -Kaunas: Technologija, 2007, Nr.1(63), p.45-49.
3. **Royzman, V., Bohorosh, A.** Dynamic characteristics identification of aircraft engine by method of trial parameters. -Mechanika. -Kaunas: Technologija, 2005, Nr.3(53), p.34-38.
4. **Zienkiewicz, O.C., Taylor, R.L.** The Finite Element Method.- Butterworth-Heinemann, 2000, v.2.-631p.
5. **Genta, G., Tonoli, A.** A harmonic finite element for the analysis of flexural, torsional and axial rotor dynamic behavior of blade arrays.- J. of Sound and Vibration, 207, 1997, p.693-720.
6. **Jonusas, R., Juzenas, E.** The investigation of steam turbine flexible rotor vibrations by means of FEM.- In Proc. of 11th World Congress on Mechanisms and Machine Science, China Machine Press 2004, v.5, p.2143-2147.

E. Juzėnas, R. Jonuřas, K. Juzėnas

SUDĖTINGŲ ROTORINIŲ SISTEMŲ VIRPESIŲ TYRIMAS PAREMTAS DINAMINIŲ PROCESŲ IR VIRPESIŲ SPEKTRO ANALIZE

Reziumė

Mechatroninės sistemos skirtos sudėtingoms rotorinėms sistemoms stebėti gali būti efektyviai panaudotos tik iš anksto žinant kritines stebimų parametrų vertes ir jų kitimo priežastis. Tokiu atveju vibrodiagnostika yra efek-

tyvi priemonė, kuri gali būti panaudota mašinų defektams nustatyti.

Aptikti visus galimus sudėtingų rotorinių sistemų defektus (pvz., vidinius rotorinių defektus), turinčius įtakos virpesių parametrų pokyčiams, yra gana sunku. Todėl, norint nustatyti įvairių parametrų įtaką mašinos vibroaktyvumui, tikslinga jos virpesius modeliuoti.

E. Juzėnas, R. Jonuřas, K. Juzėnas

RESEARCH OF COMPLEX ROTARY SYSTEMS VIBROCONDITION BASED ON ANALYSIS OF DYNAMICAL PROCESSES AND SPECTRUM OF VIBRATIONS

Summary

Mechatronic systems designed for monitoring and control of complex rotary machines can be implemented effectively only when alarm or critical levels of monitored parameters are well known and the sources of their deviations can be determined. Vibrodiagnostics is a powerful tool which can be used for the determination of machine defects.

However, in case of complex rotary machines, it is very complicated to trace all sources of vibrations (e.g. internal defects). Therefore attempts of vibrations modelling are made aiming to evaluate the influence of various parameters on the vibroactivity of certain machine.

Э. Юзенас, Р. Йонушас, К. Юзенас

ИССЛЕДОВАНИЕ ВИБРАЦИЙ СЛОЖНОЙ РОТОРНОЙ СИСТЕМЫ С ПОМОЩЬЮ АНАЛИЗА ДИНАМИЧЕСКИХ ПРОЦЕССОВ И СПЕКТРА ВИБРАЦИЙ

Резюме

Мехатронные системы, предназначены для слежения за сложными роторными системами, эффективно используются лишь в тех случаях, когда известны критические параметры роторных систем. В таких случаях vibrodiagnostika становится эффективным инструментом, который может быть использован для обнаружения дефектов сложных машин.

В случае сложный роторных систем идентификация всех возникших дефектов (например, внутренних дефектов роторов), влияющих на изменение вибраций, достаточно сложно. Поэтому приходится моделировать вибрационное состояние машины для оценки всех её параметров.

Received December 12, 2007

DOI: 10.5755/j02.mech.12157