

Integrated product and process development using rapid prototyping and rapid tooling technologies

A. Bargelis*, G. Hoehne**, A. Šačkus***

*Kaunas University of Technology, Kęstučio 27, LT-44025 Kaunas, Lithuania, E-mail: algirdas.bargelis@ktu.lt

**Ilmenau Technical University, P.O.Box 100565, D-98684 Ilmenau, Germany, E-mail: guenter.hoehne@tu-ilmenau.de

***Kaunas University of Technology, Kęstučio 27, LT-44025 Kaunas, Lithuania, E-mail: sackus@ktu.lt

1. Introduction

Manufacturing firms are forced to devise in new information systems and more intensive methods for both products design and processes development in a totally changed modern manufacturing environment. Computer Integrated Manufacturing (CIM) system is more attractive and useful for survival of a manufacturing company in quickly changing marketplaces [1]. The use of CIM systems requires a large number of advanced computer tools and high information and manufacturing technologies to assist the design of products and processes. Such techniques are indispensable for concurrent design of products and processes at an early stage of the product design in particular. Design for Manufacturing (DFM) and Design for Assembling (DFA) have been elaborated for the approaches of concurrent product and process development [2]. The implementation of these methods requires a lot of intelligent functional models and interfaces between standard Computer-Aided Design (CAD), various Computer-Aided Process Planning (CAPP) and Enterprise Resources Planning (ERP) systems, because DFM and DFA are strongly related with the above recited systems. On the other hand the shape of the newest products becomes more and more complicated and during their development the discussions among customers, developers, producers and users have to be based on virtual and physical prototypes. Virtual Prototyping (VP), Rapid Prototyping (RP) and Rapid Tooling (RT) assist in quick pattern creation of a new product as well as in its evaluation, testing, and decision making of product customization. The early stage of the product design has the greatest influence on its quality, manufacturing costs and the parameters of the product life cycle. The virtual environment, therefore, is often used for the conception of the new product development. This practice is very convenient when developers of products and processes are located in different countries and companies.

RP and RT are very effective when the results of VP are incomplete for deciding the manufacturing costs, functionality and the parameters of the new product design. The small quantity of products (1-20) produced by means of RP and RT methods can come to assistance to decision making on their handling in various marketplaces. Decision making is based on the validation and testing results of new products.

This paper deals with the creation of CIM system interfaces using RP and RT technologies for the integrated product and process development. Application of interfaces is aimed at minimizing time and costs of the new product and process development changing product structure, parts, and components as well as the production plan,

machine tools and producers. Our work has been used both in various production firms and studies in universities and colleges.

2. Computer integration of information

A lot of research results on the computer integration of information and materials flows have been practically applied in various organizations. Although this idea was formulated many years ago [3], until now, however companies have much trouble implementing this approach into industry because CIM is not the sum or totality of separate components, it links them into an inter-operating system that will satisfy the enterprise's business objectives. The integrating system is a computer system utilized jointly by the members of different functional units [4]. The main elements of CIM structure are related with the product and process design and presented in Fig. 1. The latter illustrates the integration by software and hardware of the information and material flows of three important segments in the company activities: Computer-Aided Design (CAD), Computer-Aided Process Planning (CAPP) and Computer-Aided Manufacture (CAM). The rectangular behind the circles shows the human traditional work.

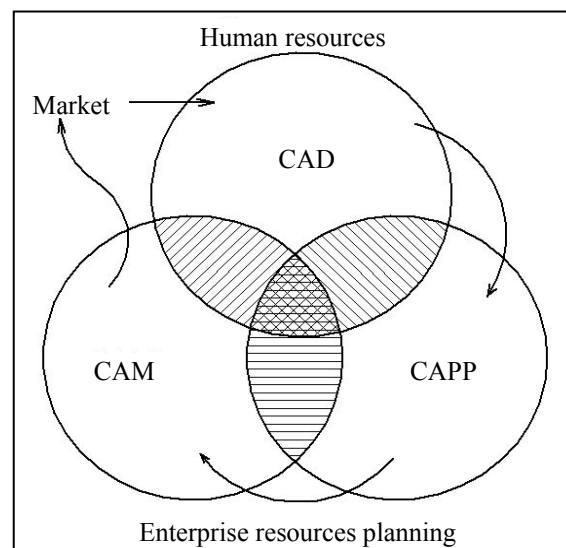

Fig. 1 The elements of CIM structure related with product and process design

The integration degree is expressed by the overlapping areas of various activities; the bigger hatched area in Fig. 1 stands for a bigger quantity of overlapping jobs which are expressed by shared data and resources in vari-

ous fields of the product and process development. There are the two types of overlapping areas: the first type (hatched areas in Fig. 1) stands for common data between two systems only (CAD and CAM, CAPP and CAM, CAD and CAPP) while the second type (twice hatched area in Fig. 1) indicates the quantity of common data for all tree systems. The integration task is to cover the hatched S and twice hatched A areas as much as possible.

$$\left\{ \begin{array}{l} S = \sum_{i=1}^2 S_i \rightarrow \max \\ \text{and} \\ A = \sum_{j=1}^3 A_j \rightarrow \max \end{array} \right. \quad (1)$$

The hatched area can be increased by developing interfaces, intelligent functional models and interfacing modules in CIM environment. An interface is a connection resource for hooking to the output results of the other system (an external interface) or for hooking one system's component to the other one (an internal interface) An intelligent functional model can improve the system performance by saving and minimizing costs of the product and

process development. An interfacing module can test and evaluate each product and process alternative according to the selected parameter while an interface can transfer data from one system to the other seeking only the integrity of both systems.

Taking into account our early research [5], we have developed a framework of the integrated product and process development using rapid prototyping and rapid tooling technologies (Fig. 2). It is devoted to the product conception and final stages of any production type. External interfaces EI1 and EI2 are used for hooking the product and process development systems in the conception and batch production stages. Thus, the different data of each integrated system has its own specific structure and whole data N of an integrated system is expressed as follows

$$N = (CP) \cup (EI1) \cup (CR) \cup (BP) \cup (EI2) \cup (BR) \quad (2)$$

where CP and BP are the product data in the concept and batch design stage, respectively; CR and BR are the process data in the concept and batch design stage, respectively; $EI1$ and $EI2$ are the external interfaces in both product development stages.

The key part of a conception product stage is vir-

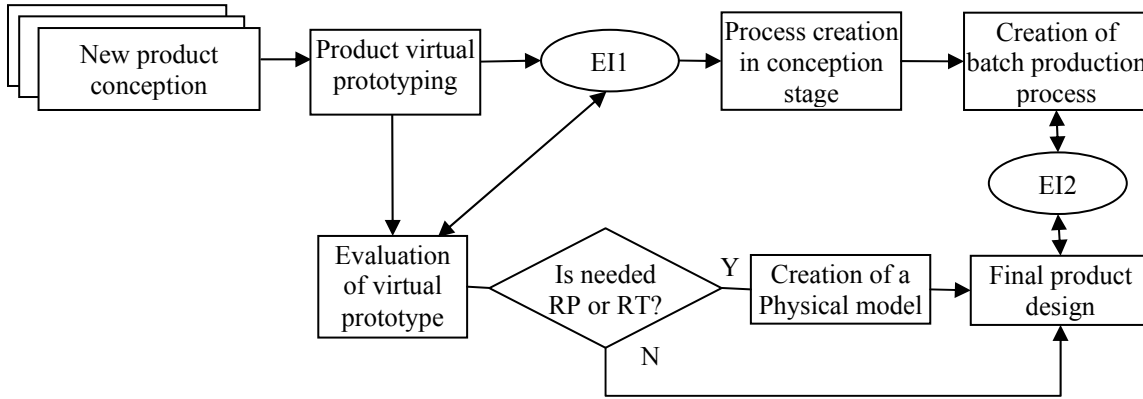

Fig. 2 Framework of the integrated product and process development using RP and RT technologies

tual prototyping (Fig. 3). Three internal interfaces I1, I2 and I3 have been used for product virtual prototyping. Interface I1 hooked the module of customer requirements and standard CAD system, interface I2 hooked the generated virtual prototype and optimization technique, interface I3 hooked the optimum virtual product prototype and validation and testing technique. From available alternatives satisfying all customer requirements the optimal selection of product virtual prototype V has been made using the following objective function

$$V = \sum_{j=1}^s (Mh)_j + \sum_{l=1}^r (G)_l f \rightarrow \min \quad (3)$$

where M is the mass of a work piece, kg; h is the cost of a material, money units; G is the number of standard components; f is the cost of each component, m.u.

The algorithm of integrated process creation at the product conception stage is presented in Fig. 4. Three internal interfaces I4, I5 and I6 have been used for creating the process. Interface I4 hooks the input common data of process creation that are prepared in a product virtual pro-

totyping system to the generation module of process alternatives. We have used our early developments [6, 7] as a process alternative creation module. Interface I5 hooks the created process alternative to process optimization technique [8]. Interface I6 hooked the optimum process to validation and testing technique.

After the process evaluation procedure the common data for producer selection is optimal production process BR using optimum criterion $C(BR)_k$ for each alternative of the process

$$\{C(BR)_k\}: C(BR)_1 > C(BR)_2 > \dots > C(BR)_n \rightarrow \min \quad (4)$$

This criterion can be expressed as minimum production resources

$$\forall (BR)_k \exists (O(D_i)) \times I(D_i) \times \{L_1, L_2, \dots, L_s\} \rightarrow \min \quad (5)$$

where $O(D_i)$ are the operations of product $(BP)_k$ design feature D_i ; $I(D_i)$ is the set of manufacturing resources of design feature D_i ; $\{L_1, L_2, \dots, L_s\}$ is the set of manufacturing rules for design feature D_i .

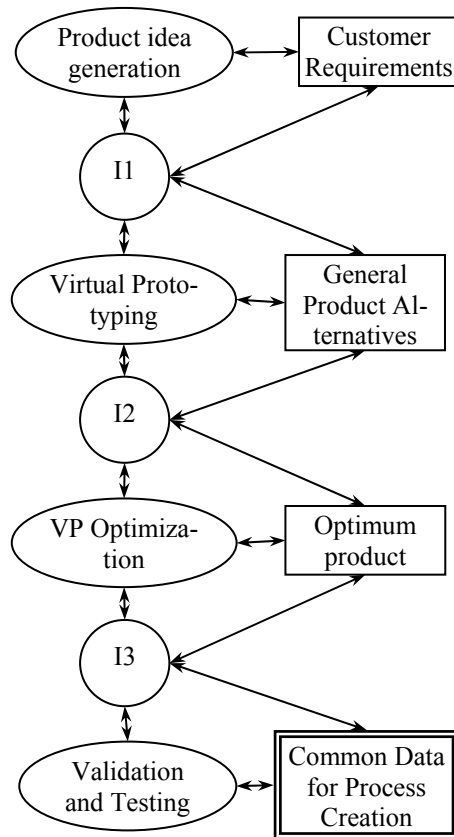

Fig. 3 Virtual prototyping of a product

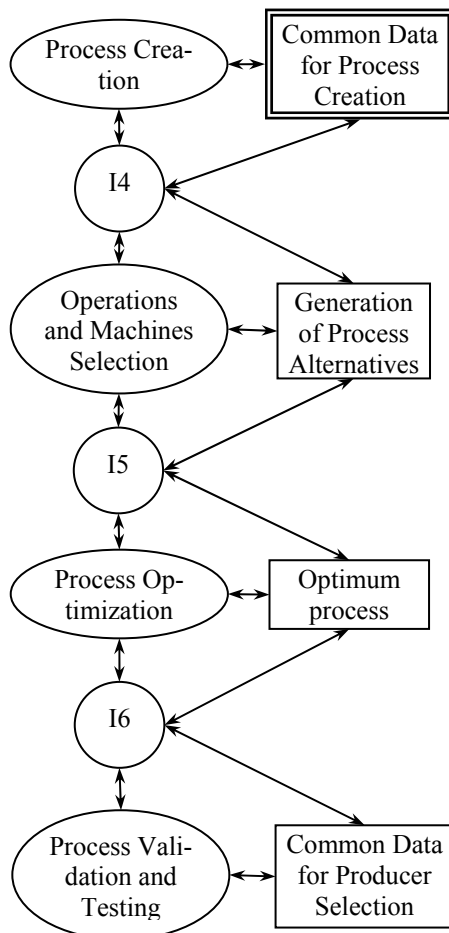

Fig. 4 Integrated process creation

Data BP of a batch production product and process data BR which have lower value of optimization criterion $C(BR)_k$ defined by expression (4) are fixed as common data for the producer selection of a product BP . The set of manufacturing rules $\{L_1, L_2, \dots, L_s\}$ for each design feature D_l of product BP has a tremendous influence on $C(BR)_k$ value minimization. Rapid prototyping and rapid tooling (RP & RT) can help to define the D_l parameters of each part for product BP achieving its best performance and minimization of manufacturing costs. The appropriate software is developed and used for the embodiment of integrated product and process design. In section 3 the principles of selection RP and RT technologies for the integrated product and process design are considered.

3. Selection of RP and RT for integrated product and process design

RP and RT technologies can quickly provide the models of a physical product or part from their 3D CAD virtual prototypes. It is shown [5] that these technologies are very expensive and often the producers of RP physical model are located at big distances from its users, so that production and delivery time takes 7-10 days. On the other hand, these technologies cannot be used for all products or parts. Table 1 presents the classification of products in Lithuanian industry and the possibilities to use RP and RT processes for them. The data of Table 1 were collected using a specialized questionnaire and the efforts of both KTU postgraduate students and employees of companies.

Table 1

Classification of products via possibility to use RP & RT

Class No.	Product Type	% parts for RP & RT	Probability of use RP & RT
1.	Sheet metal design	0	0
2.	Cisterns, tanks	3	0.015
3.	Heating boiler	5	0.025
4.	Bicycles	10	0.050
5.	Furniture	15	0.100
6.	Electro motors	18	0.130
7.	TV products	21	0.160
8.	Refrigerators	24	0.190
9.	Machine tools	27	0.220
10.	Mechatronics	32	0.270

The low level of RP & RT use in Lithuanian industry can be explained by these circumstances:

- not so many developers of new products;
- erroneous opinion that these processes are very expensive;
- insufficient information on RP & RT technologies and the potential producers of prototypes.

When VP of a new product is optimized and selected (Fig. 3), a physical model is necessary for testing functionality or visualization in the debates of customers and producers. Then the algorithm for the selection of optimum RP & RT technologies is proposed (Fig. 5). The algorithm makes use of a product 3D CAD model and common data for process creation, when the first step is creation of .stl file. The production stage of a RP model is related with an appropriate Knowledge Base (KB). The objective of KB is generating an optimal RP or RT method

according to the product or part requirements. The last step of a production stage is the post process during which the RP physical model is finished and cured. An RP model is evaluated by specialized criteria. Two values of evaluation criteria, namely deviation of geometry form and dimensions between 3D CAD part model and RP physical model are used. A specialized measuring machine (CMM) or 3D scanning equipment is applied. The deviation of each parameter is defined by appropriate tolerances. Three internal interfaces I7, I8 and I9 are employed in the algorithm of RP and PT technologies selection. I7 hooks the data of a product 3D CAD model with the production model; I8 hooks the RP physical model data with the evaluation criteria and I9 hooks the tested and evaluated physical RP model data with the common data for final recommendation decisions in the product and process design.

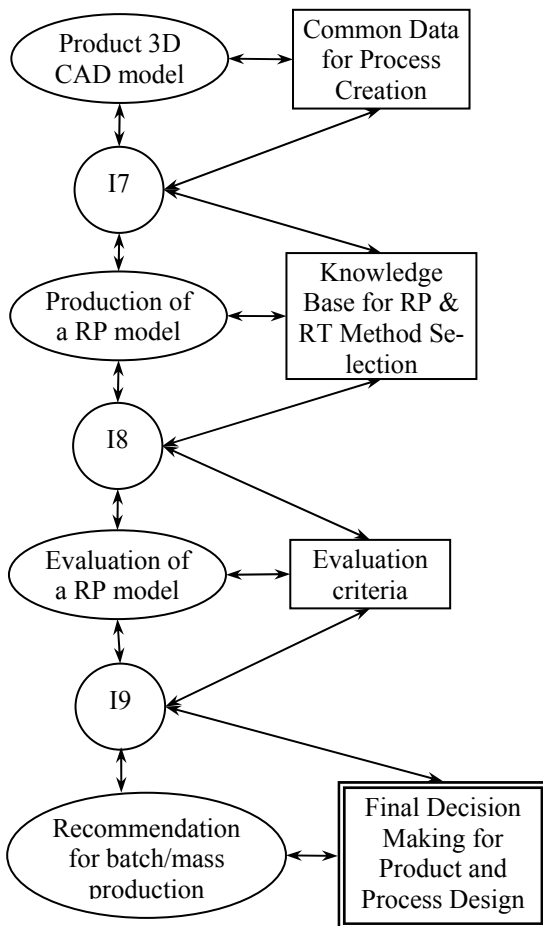

Fig. 5 Selection of RP and RT technologies

The KB structure for RP and RT selection is presented in Fig.6. It consists of four main DB blocks. The first block holds available materials for RP & RT processes; the second block contains the available RP & RT technologies and their capabilities. The third block contains the process selection rules and the fourth one holds the information on optimum RP&RT processes, facilities, producers and other attributes as costs, delivery time and so on. The case studies of the possibilities of the developed system are presented in Section 4.

The knowledge on available materials is contained in the materials block of RP processes. The materials are classified into two groups: thermoplastics and the others. The suitable materials corresponding to the grade or

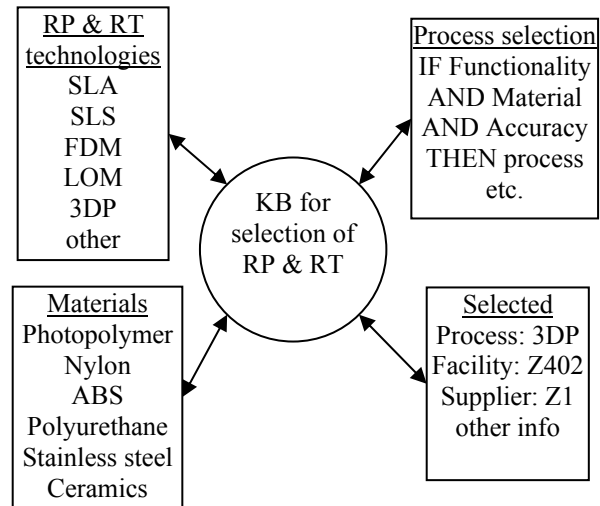

Fig.6 KB structure for RP & RT selection

its equivalent can be chosen as the properties of specialized materials used in RP & RT processes are close to their mechanical components. In some cases the material used for making RP model does not play any role, e.g. the material for visualization is selected according to the other parameters of a part.

The knowledge on RP & RT processes and their possibilities is in the second knowledge base block. It is related with known technologies, materials used there, achieved accuracy, feasible application of RP model, proper equipment, production time calculation, calculation of production and material costs. All this knowledge is indispensable in the choice of the optimum RP technological process, i.e. it has to come to assistance when choosing the most suitable equipment for a given task. The knowledge of production processes of prototypes is constantly supplemented by newly sprung technologies and revised with respect to the alternatives and consumer wishes. The extensive base of this technologies knowledge is presented with examples in the web site www.iidsp.net.

The process is selected by IF-THEN rules accumulated in the third block. By applying IF-THEN rules the existing information is analysed and decisions are made. The rules are presented as follows: IF (condition) THEN (conclusion or operation). The rule is applied only when the facts being analysed coincide with IF operator's conditions. The applied IF-THEN rule creates new facts or data which are also analysed for applying new rules. The decision search is over when the knowledge base has no rules to be applied. It is a direct reasoning method. The fragment of rules based on IF-THEN condition for Stereolithography (SLA) RP method selection is presented in Table 2.

The fourth block gives the selected optimal process. It accumulates facts and data on previously used mechanical components and optimal RP & RT technologies developed for them, equipment, materials, costs and delivery to customer time.

The efficiency and accuracy of developed KB depend on the completeness of facts, data and rules associated with RP & RT technologies. The use of KB for problem solving is not a new research method. A rule based on the expert system for RP facility and vendor method choice [9] considers the best suitable technique selection for producers of RP physical models.

Table 2

IF-THEN rules for SLA
IF Functionality= <i>Visualization</i> AND Material= <i>photopolymer</i> AND Accuracy= <i>fine</i> THEN propose= <i>use SLA</i> ;
IF Functionality= <i>Function tests</i> AND Material= <i>photopolymer</i> AND Accuracy= <i>medium</i> THEN check= <i>quantity</i> ;
IF Functionality= <i>Function tests</i> AND Material= <i>photopolymer</i> AND Accuracy= <i>fine</i> THEN check= <i>quantity</i> ;
IF Functionality= <i>Final part</i> AND Material= <i>photopolymer</i> AND Accuracy= <i>medium</i> THEN check= <i>quantity</i> ;
IF Functionality= <i>Final part</i> AND Material= <i>photopolymer</i> AND Accuracy= <i>fine</i> THEN check= <i>quantity</i> ;
IF Quantity= <i>from 100 up to 1000</i> AND Volume= $<0.1\text{cm}^3$ THEN propose= <i>use SLA</i> ;
IF Quantity= <i>from 5 up to 100</i> AND Volume= $<1\text{cm}^3$ THEN propose= <i>use SLA</i> ;
IF Quantity= <i>from 1 up to 4</i> AND Volume= $<100\text{cm}^3$ THEN propose= <i>use SLA</i> ;

Tele RP – an Internet web-based solution for remote RP service [10] investigates the methodology to create an appropriate infrastructure, whose main functions include submitting, queuing and monitoring of remote parts. Our research is aimed at creating an integrated system of the product and process development using optimal RP & RT technologies which consequently optimize product and process design stages. The last optimization stage is creation of the optimum RP & RT process by the following objective functions

$$T = \sum_{k=1}^V (V)_k g + T_{post} + T_{del} \rightarrow \min \quad (6)$$

and

$$N = N_m + N_{rp} + N_{del} \rightarrow \min \quad (7)$$

where T is total production and delivery time of RP physical model to the customer, hrs; V is the volume of a part, cm^3 ; g is the production time of 1 cm^3 volume part, hrs; T_{post} is post manufacturing time of a RP physical model, hrs; T_{del} is the model delivery time to the customer, hrs; N is total costs of a RP physical model, Lt; N_m is the material costs, Lt; N_{rp} is common manufacturing costs, Lt; N_{del} is the delivery costs, Lt.

Considering the results defined by (6) and (7) expressions, contradiction between T and N can frequently be found: when T is going to T_{min} , N is going to N_{max} . The optimum version is when both T and N can achieve their lowest values.

The best event: $T \rightarrow T_{min}$ and $N \rightarrow N_{min}$.

The worst event: $T \rightarrow T_{max}$ and $N \rightarrow N_{max}$.

Developed KB helps achieving the best balance between values T and N .

4. Case studies

4.1. Selection of optimum RP technologies

Lithuanian company X1 that produces consumer goods applying testing and evaluation of a developed system has been considered. The “Ornament cover” has been selected for a testing part (Fig. 7). The first stage of testing the selected part was to design some VP alternatives, then they have been evaluated by expression (3), and the opti-

num variant of VP has been chosen. Prior to creation of a batch/mass process by an algorithm in Fig. 4, it is necessary to obtain and consider physical RP model of the selected part. The tasks of RP technology for the selected part and its data are presented in Table 3. The input data of the selected part is proceeded by the scheme presented in Fig. 5. The obtained results are presented in Table 4.

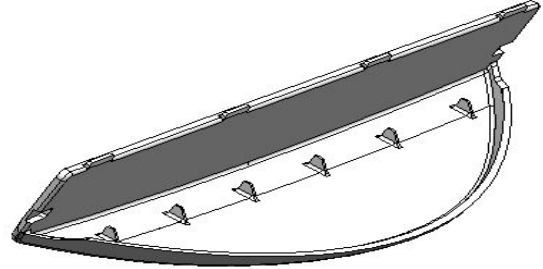

Fig 7 Investigated part “Ornament cover”

Table 3

Data and testing tasks of a part

Data	Task 1	Task 2
Part name	Ornament cover	Ornament cover
Prototype functionality	Visualization	Function tests
Prototype material	No data	ABS
Prototype accuracy	Medium	Fine
Quantity	1	1
Volume cm^3	60.5	60.5

The prototype accuracy is classified into three different types:

- very fine then the part accuracy is up to 0.1mm;
- fine then the part accuracy is up to 0.15mm;
- medium then accuracy is more than 0.15mm.

Table 4

Testing results of a part “Ornament cover”

Data	Task 1	Task 2
Prototype material	Starch	ABS
Technology	3DP	FDM
Equipment	Z402	Dimension
Supplier	Company Z1	Company Z2

Using RP&RT technologies and conventional production methods total costs have been investigated. The results of these considerations are presented in Table 5 and Fig. 8.

Table 5

Investigation results

Parameter	RP methods		Traditional methods	
	3DP	FDM	Injection moulding	Machining
Material costs, Lt	21	No data	2,77	63,84
Equipment production costs, Lt	No	No	15 000	12000
Model production costs, Lt	930	3400	3,55	160
Total costs, Lt	930	3400	16 000	13 000
Model production time, hrs	3.78	9.03	160	130
Tentative model production time from order to delivery, in days	6-10	10-12	34-50	16-20

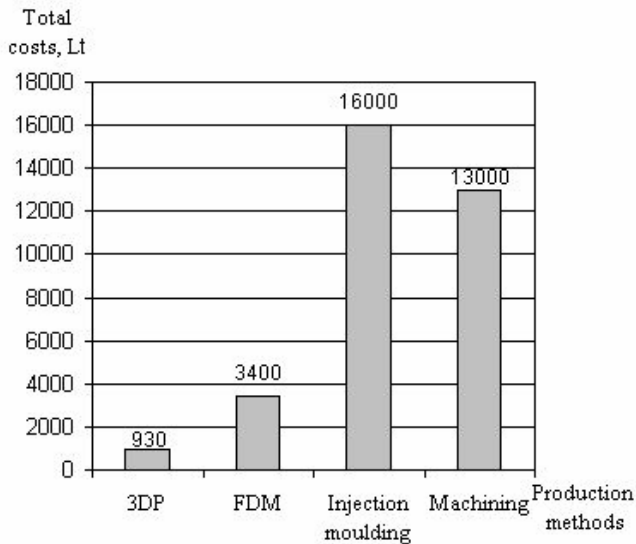

Fig. 8 Graphical presentation of various physical model production results

4.2. Selection of the optimum RT technologies

Lithuanian company X2 that produces mechatronic components has received an order for a quick delivery of 10 products Y1 (Fig. 9) and 100 products Y2 (Fig. 10) to practice their evaluation parameters in various customer factories. The main data of tested parts are presented in Table 6, and the obtained results of the selection optimum RT technologies are presented in Table 7.

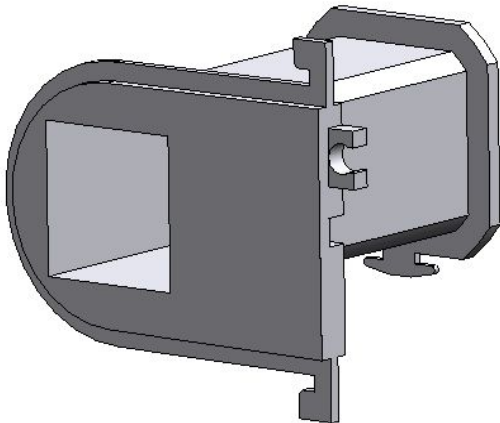

Fig. 9 Investigated part Y1

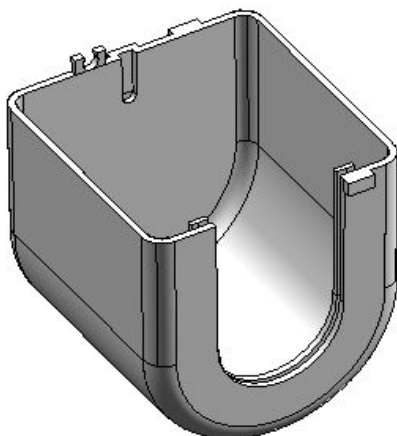

Fig. 10 Investigated part Y2

Parts data and testing tasks

Data	Part Y1	Part Y2
Part name	Housing	Housing
Prototype functionality	Function tests	Function tests
Prototype material	Polyurethane	Polyurethane
Prototype accuracy	Medium	Medium
Quantity	10	100
Volume cm ³	2.7	5.2

Table 7

Testing results of a part "Ornament cover"

Data	1 task	2 task
RT technology	Silicon mould	Spin casting
Equipment	Vacuum chamber	Spin casting
Delivery time, days	10-12	15-20
Supplier	Company Z2	Company Z3

5. Conclusions

To sum up, we can conclude that rapid prototyping (RP) and rapid tooling (RT) technologies increase the integration level of the product and process development in CIM environment, in particular when patterns are necessary. On the other hand, in global manufacturing environment the research done can help finding the best developers and producers of new products. The optimization method and KB system proposed in this paper provide the logically and mathematically based criteria values for a product, its pattern and the process development.

When viewed from the point of practical application of this research, we can emphasize the following advantages:

- the proposed objective function and appropriate software for the optimization of product VP alternatives allocate them according to the costs;
- the performed their preliminary analysis of the possibilities to use RP & RT technologies in Lithuanian industry shows that they can be slightly increased;
- the experimental investigations of the developed KB structure and the optimization methodology confirm the results obtained by mathematical and logical propositions;
- the developed KB structure generates an optimal RP and RT technology that is substantiated by logical and mathematical expressions.

However, the carried out research still needs further acquisition of facts, data and rules of KB and more tests of mathematical expressions and experimental considerations. It is expected that these problems will be solved with the improving mathematical model and revising KB data.

Acknowledgments

The research described here was under the partial support of contracts No.8083 (2003 year) and No.8194 (2004 year) among KTU and Lithuanian industrial companies. Special thanks should also go to Dr. K.Wodzicka from Germany company PORTEC GmbH for consultations and practical suggestions.

References

1. **Rehg, J.A., Kreaber, H.W.** Computer Integrated Manufacturing.-Columbus, Ohio, 2001.-592p.
2. **Boothoyd, G., Dewhurst, P., Knight, W.** Product Design for Manufacture and Assembly.-New York: Marcel Dekker, 2002.-698p.
3. **Harrington, J.** Computer Integrated Manufacturing.-New York: Industrial Press, 1973.-296p.
4. **Alsene, E.** The Computer integration of the enterprise.-IEEE Transactions on Engineering Management, 1999, v.46(1), p.26-35.
5. **Šačkus, A., Hoehne, G., Bargelis, A.** The virtual prototyping as a smart technique for increasing efficiency of rapid prototyping. -Mechanika. -Kaunas: Technologija, 2002, No.4(36), p.48-53.
6. **Bargelis, A., Česnulevičius, A., Stasiškis, A., Šačkus, A.** Intelligent manufacturing engineering based on multi agent tools.-Mechanika.-Kaunas: Technologija. 2003, No1(39), p.40-47.
7. **Bargelis, A.** The modelling structure of intelligent manufacturing system for mechanical components.-Proc. of the 2nd Int. Conf. on Integrated Design and Manufacturing in Mechanical Engineering (ID-MME'98), Compiègne, France, 1998, p.1117-1124.
8. **Bargelis, A., Hoehne, G., Česnulevičius, A.** Intelligent functional model for costs minimization in hybrid manufacturing systems. -Informatica, 2004, v.15, No1, p.3-22.
9. **Jiang, P., Fukuda, S.** TeleRP – an internet web-based solution for remote rapid prototyping service and maintenance.-Int. J. of Computer Integrated Manufacturing, 2001, v.14, No1, p.83-94.
10. **Masood, S. H., Soo, A.** A rule based expert system for rapid prototyping system selection.-Robotics and Computer Integrated Manufacturing, 2002, v.18, p.267-274.

A. Bargelis, G. Hoehne, A. Šačkus

INTEGRUOTAS GAMINIO IR PROCESO KŪRIMAS
 TAIKANT SPARČIOSIOS PROTOTIPŲ IR TECHNOLOGINĖS ĮRANGOS GAMYBOS TECHNOLOGIJAS

Reziumė

Straipsnyje nagrinėjama integruoto gaminių ir procesų kūrimo metodologija taikant sparčiosios prototipų (RP) ir technologinės įrangos gamybos (RT) technologijas. Sukurtas metodas jungia naujai suprojektuoto gaminio virtualų ir fizinį modelius. Pasiūlytas nuoseklaus optimizavimo modelis, dalijantis optimizavimo procedūrą į du etapus. Pirmasis etapas skirtas naujų gaminių virtualiems prototipams optimizuoti. Šiai užduočiai atlikti pasiūlyta tikslo funkcija. Antrajame etape optimalioms RP ir RT technologijoms parinkti taikoma specializuota žinių bazė (KB). Sukurta metodologija išbandyta eksperimentiškai.

A. Bargelis, G. Hoehne, A. Šačkus

INTEGRATED PRODUCT AND PROCESS DEVELOPMENT USING RAPID PROTOTYPING AND RAPID TOOLING TECHNOLOGIES

Summary

The paper is on the methodology of integrated product and process development using rapid prototyping (RP) and rapid tooling (RT) technologies. The generated method integrates the virtual and physical model of a new product design. The consequence optimization model has been proposed which classifies the optimization procedure into two stages. The first stage is devoted to optimizing virtual prototypes of new products. The objective function for this task has been proposed. In the second stage the specialized knowledge base (KB) has been applied for the optimum selection of RP & RT technologies. The created methodology has been tested by appropriate experiments.

A. Баргялис, Г. Хионе, А. Шачкус

ИНТЕГРИРОВАННОЕ РАЗВИТИЕ ИЗДЕЛИЯ И ПРОЦЕССА ПРИ ИСПОЛЬЗОВАНИИ ТЕХНОЛОГИЙ БЫСТРОГО ПРОТОТИПИРОВАНИЯ И УСКОРЕННОГО ПОЛУЧЕНИЯ ТЕХНОЛОГИЧЕСКОЙ ОСНАСТКИ

Резюме

В статье разобрана методология интегрального развития изделия и процесса, используя технологии быстрого прототипирования (RP) и ускоренного получения технологической оснастки (RT). Созданный метод объединяет виртуальную и физическую модели заново спроектированного изделия. Была предложена модель последственной оптимизации, которая разделяет процедуру оптимизации на две стадии. Первая стадия предназначена для оптимизации виртуальных прототипов новых изделий. Для этой задачи была предложена функция цели. Во второй стадии оптимизации специализированная база знаний (KB) была применена для оптимального выбора технологий RP и RT. Созданная методология была проверена соответствующими экспериментами.

Received September 24, 2004

DOI: 10.5755/j02.mech.12874