

Dynamic synthesis of the recoil imitation system of weapons

A. Fedaravičius*, M. Ragulskis**, E. Sližys***

*Kaunas University of Technology, Kęstučio 27, LT-44025 Kaunas, Lithuania, E-mail: alfedar@ktu.lt

**Kaunas University of Technology, Kęstučio 27, LT-44025 Kaunas, Lithuania, E-mail: minvydas.ragulskis@ktu.lt

***Kaunas University of Technology, Kęstučio 27, LT-44025 Kaunas, Lithuania, E-mail: eslizys@ktu.lt

1. Introduction

Lately laser trainers have been effectively used for riflemen and sportsmen training [1 - 3]. However, the majority of trainers have neither real recoil nor sound imitation systems. For this reason the objective of this work is to investigate the recoil of some rifle under single and serial shooting regimes and their interaction with a shot so that training equipment could be created with a complete recoil imitation.

It is clear that the training equipment of the riflemen must reproduce the process of single shots and shot serial as precisely as possible [4]. Thus the efficiency of the training equipment is determined by the maximum reproduction of physical and psychological influence characteristics on a riflemen of the real fighting guns (shot and shot serial, recoil and sound, imitation of real fighting situation etc.) and rendering of additional information to the shooting instructor and the rifleman through the additional informational systems (e.g. position of the sight at the moment of a shot, the process of trigger pressing, the correctness of butt pressing to the rifleman's shoulder, the

trajectory of gun targeting etc.). When developing the laser riflemen's trainer, having to imitate weapon recoil at the shot time in vertical and horizontal directions, it is essential to analyze the recoil characteristics of the rifle under consideration.

2. Theoretical investigation

Previously was analyzed the movement of a rifle during recoil assuming that a bolt is not moving within the rifle. The investigated mathematical model of the rifle's planar motion is not precise since it does not evaluate the impact of the gun bolt movement during a shot. In a real rifle, the recoil force, first of all, forces the bolt to move but does not impact the rifle directly as it was formerly analyzed. While moving within the rifle the bolt impacts the movement of the rifle during a shot. In order to revise the mathematical model investigated, it is necessary to determine the forces impacting the bolt and the rifle. The diagram of forces acting on the weapon when it is fired has been drawn up (Fig. 1).

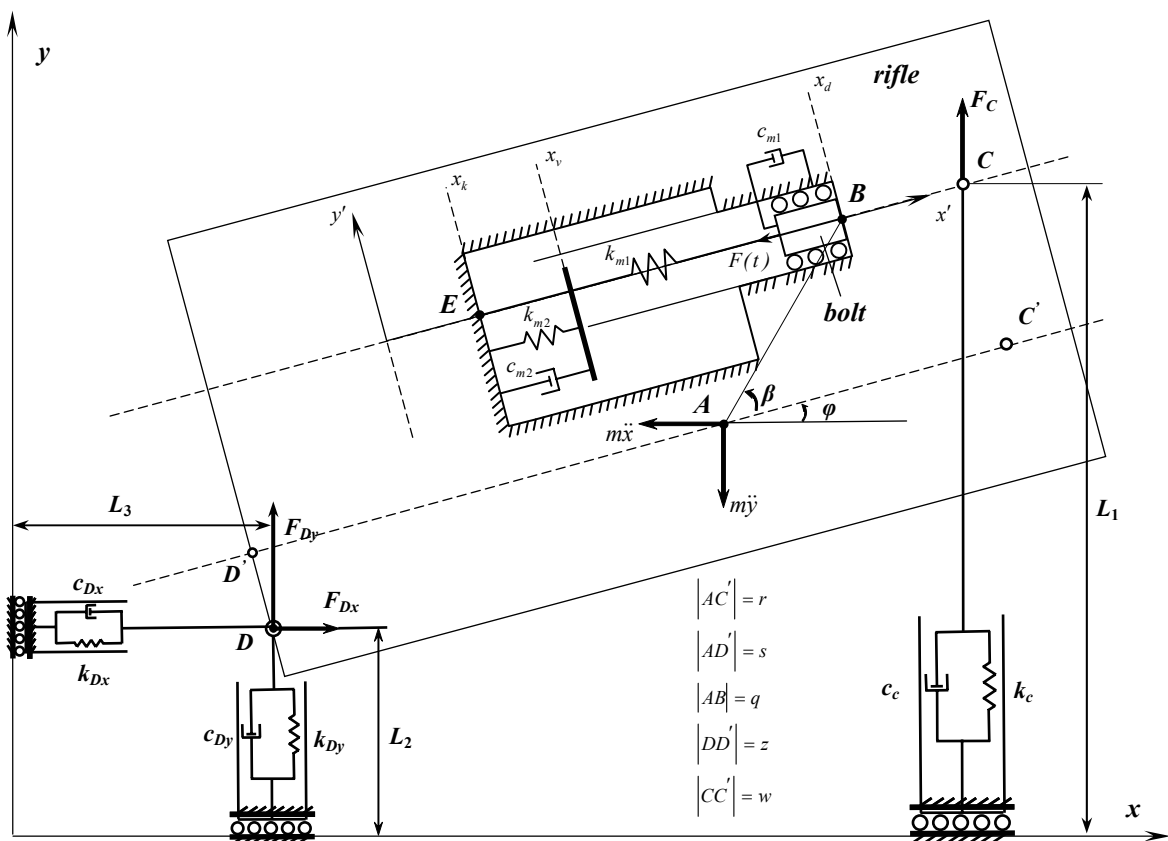

Fig. 1 Diagram of forces acting on the weapon

Differential equations of weapon's planar motion have been written and investigated. In the diagram the centre of gravity is in the point A(x,y). Weapon's butt rests against a rifleman's shoulder and the weapon receiver is held with one hand.

During recoil, the forces of stiffness and damping are acting in the points C and D. Distances L_1, L_2, L_3 describe the condition of equilibrium. In point B recoil force $F(t)$ is active. The coordinates of points, taking into account the gravity centre position, in plane xy are as follows

$$\left. \begin{aligned} B &= (x + qc \cos(\varphi + \beta), y + qs \sin(\varphi + \beta)) \\ C' &= (x + rc \cos \varphi, y + rs \sin \varphi) \\ D' &= (x - sc \cos \varphi, y - ss \sin \varphi) \\ C &= (x + r \cos \varphi - w \sin \varphi, y + r \sin \varphi + w \cos \varphi) \\ D &= (x - s \cos \varphi + z \sin \varphi, y - s \sin \varphi - z \cos \varphi) \end{aligned} \right\} \quad (1)$$

The forces, acting in points C and D are evaluated by equations

$$\left. \begin{aligned} F_C &= -k_C(y + r \sin \varphi + w \cos \varphi - L_1) - \\ &- c_C(\dot{y} + r \cos \varphi \dot{\varphi} - w \sin \varphi \dot{\varphi}) \\ F_{D_x} &= -k_{D_x}(x - s \cos \varphi + z \sin \varphi - L_3) - \\ &- c_{D_x}(\dot{x} + s \sin \varphi \dot{\varphi} + z \cos \varphi \dot{\varphi}) \\ F_{D_y} &= -k_{D_y}(y - s \sin \varphi - z \cos \varphi - L_2) - \\ &- c_{D_y}(\dot{y} - s \cos \varphi \dot{\varphi} + z \sin \varphi \dot{\varphi}) \end{aligned} \right\} \quad (2)$$

where k_C, k_{D_x}, k_{D_y} are coefficients of stiffness; c_C, c_{D_x}, c_{D_y} are coefficients of damping.

The gun bolt is moving by the axis x' . The equation describing the movement of the bolt will depend upon its position on this axis. The bolt's coordinates are $S(x_{m1}, 0)$. The following four cases will be analyzed in such manner.

1) When $x_v < x_{m1} < x_d$, the equation, describing the bolt movement is as follows

$$m_1 \ddot{x}_{m1} + c_{m1} \text{sign}(\dot{x}_{m1}) + k_{m1} x_{m1} = F(t) + F_{cf} \quad (3)$$

Equations describing the rifle movement

$$\left\{ \begin{aligned} m_1 \ddot{x}_{m1} + (c_{m1} + c_{m2}) \text{sign}(\dot{x}_{m1}) + (k_{m1} + k_{m2}) x_{m1} &= F(t) + F_{cf} \\ m \ddot{x} &= F_{D_x} + (c_{m1} + c_{m2}) \text{sign}(\dot{x}_{m1}) \cos \varphi + (k_{m1} + k_{m2}) x_{m1} \cos \varphi \\ m \ddot{y} &= F_{D_y} + F_C + (c_{m1} + c_{m2}) \text{sign}(\dot{x}_{m1}) \sin \varphi + (k_{m1} + k_{m2}) x_{m1} \sin \varphi \\ I \ddot{\varphi} &= F_{D_x} (s \sin \varphi + z \cos \varphi) - F_{D_y} (s \cos \varphi - z \sin \varphi) + F_C (r \cos \varphi - w \sin \varphi) - \\ &- (c_{m1} + c_{m2}) \text{sign}(\dot{x}_{m1}) w - \\ &- (k_{m1} + k_{m2}) x_{m1} w \end{aligned} \right. \quad (9)$$

3) When the bolt strikes against the left side at point E, the force impacting the rifle will be equal to $F_{sm} = \frac{m_1(1 + R_{sm})\dot{x}_{m1}}{\Delta t}$ and its direction is opposite to x' direction.

Bolt velocity prior to a blow \dot{x}_{m1} , after a blow $R_{sm}(-\dot{x}_{m1})$, where R_{sm} is coefficient of restitution, $0 < R_{sm} < 1$; Δt is duration of the impact.

where

$$\text{sign}(\dot{x}_{m1}) = \begin{cases} 1, & \text{when } \dot{x}_{m1} > 0 \\ -1, & \text{when } \dot{x}_{m1} < 0 \\ 0, & \text{when } \dot{x}_{m1} = 0 \end{cases} \quad (4)$$

F_{cf} is centrifugal force, acting on the bolt by axis x' , which is equal to $m_s R \dot{\varphi}^2$; m_s is mass of the bolt; $\dot{\varphi}$ is angular velocity of the bolt

$$\dot{\varphi} = \frac{\phi_2|_{t=t_{i+1}} - \phi_1|_{t=t_i}}{dt} \quad (5)$$

where $i = 0, 1, 2, \dots, n$.

Radius of bolt rotation

$$R = \frac{R_2|_{t=t_{i+1}} + R_1|_{t=t_i}}{2} \quad (6)$$

At point B the rifle will be impacted by force $c_{m1} \text{sign}(\dot{x}_{m1})$ and at point E by force $k_{m1} x_{m1}$.

Equations describing the rifle movement

$$\left\{ \begin{aligned} m_1 \ddot{x}_{m1} + c_{m1} \text{sign}(\dot{x}_{m1}) + k_{m1} x_{m1} &= F(t) + F_{cf} \\ m \ddot{x} &= F_{D_x} + c_{m1} \text{sign}(\dot{x}_{m1}) \cos \varphi + k_{m1} x_{m1} \cos \varphi \\ m \ddot{y} &= F_{D_y} + F_C + c_{m1} \text{sign}(\dot{x}_{m1}) \sin \varphi + k_{m1} x_{m1} \sin \varphi \\ I \ddot{\varphi} &= F_{D_x} (s \sin \varphi + z \cos \varphi) - F_{D_y} (s \cos \varphi - z \sin \varphi) + \\ &+ F_C (r \cos \varphi - w \sin \varphi) - c_{m1} \text{sign}(\dot{x}_{m1}) w - k_{m1} x_{m1} w \end{aligned} \right. \quad (7)$$

2) When $x_k < x_{m1} < x_v$

$$m_1 \ddot{x}_{m1} + (c_{m1} + c_{m2}) \text{sign}(\dot{x}_{m1}) + (k_{m1} + k_{m2}) x_{m1} = F(t) + F_{cf} \quad (8)$$

At point B the rifle will be impacted by force $(c_{m1} + c_{m2}) \text{sign}(\dot{x}_{m1})$ and at point E by force $(k_{m1} + k_{m2}) x_{m1}$.

Equations describing the rifle movement

$$\left\{ \begin{aligned} m \ddot{x} &= F_{D_x} - F_{sm} \cos \varphi \\ m \ddot{y} &= F_{D_y} + F_C - F_{sm} \sin \varphi \\ I \ddot{\varphi} &= F_{D_x} (s \sin \varphi + z \cos \varphi) - F_{D_y} (s \cos \varphi - \\ &- z \sin \varphi) + F_C (r \cos \varphi - w \sin \varphi) + F_{sm} w \end{aligned} \right. \quad (10)$$

4) When the bolt strikes against the right side at

point B, the force impacting the rifle will be equal to: $F_{sm} = \frac{m_1(1+R_{sm})\dot{x}_{m1}}{\Delta t}$ and its direction will be coincident with x' direction.

Equations describing the rifle movement

$$\begin{cases} m\ddot{x} = F_{Dx} + F_{sm} \cos \varphi \\ m\ddot{y} = F_{Dy} + F_C + F_{sm} \sin \varphi \\ I\ddot{\varphi} = F_{Dx}(s \sin \varphi + z \cos \varphi)\varphi - F_{Dy}(s \cos \varphi - z \sin \varphi) + F_C(r \cos \varphi - w \sin \varphi) - F_{sm}w \end{cases} \quad (11)$$

Differential equations of weapon's plane motion are solved by using *Runge-Kutta* algorithm of 12 steps of 8(6) order [5, 6]. This algorithm automatically selects an integration step taking into account the velocity rate of the process. Taking into account the fact that biomechanical characteristics of riflemen's hands and shoulders differ, the following values of the coefficients of stiffness and damping were used for calculations: $k_C=100 - 400$ N/m; $k_{Dx}=300 - 1000$ N/m; $k_{Dy}=700 - 1700$ N/m; $c_C=10 - 40$ Ns/m; $c_{Dx}=30 - 70$ Ns/m; $c_{Dy}=50 - 100$ Ns/m. The samples of solutions are given in Fig. 2.

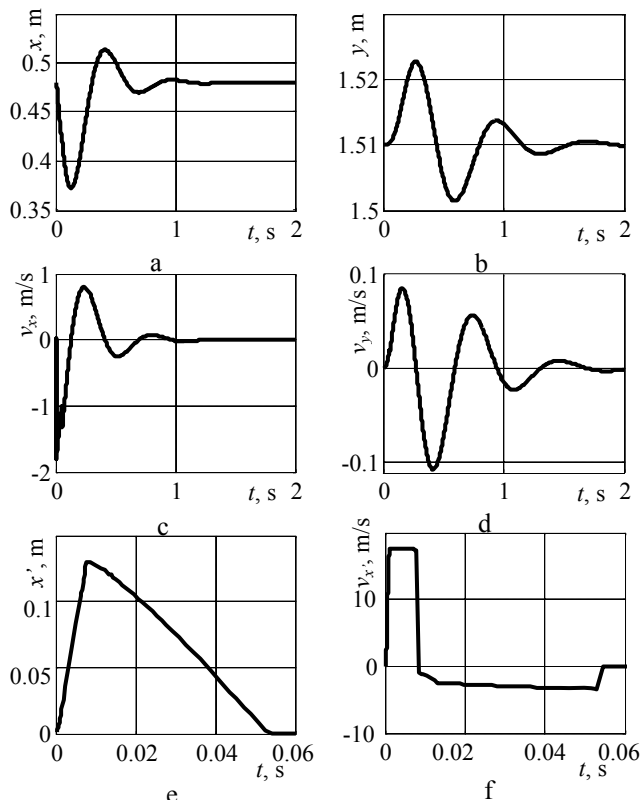

Fig. 2 Imitation of a single shot: a - displacement along x axis; b - displacement along y axis; c - velocity along x axis; d - velocity along y axis; e - bolt displacement along x' axis; f - bolt velocity along y' axis

3. Constructive synthesis of recoil imitation system of the rifle

The unit scheme of the riflemen's trainer with regulated imitation of shot recoil is depicted in the drawing. The riflemen's training equipment (Fig. 3) consists of an automatic rifle 1 that can fire single shots and shot se-

ries, a target and the system of shot imitation (not shown in the drawing). The rifle 1 has a pre-installed feeding system of compressed air 2. In the chamber of the weapon's barrel 3 is installed electromagnetic valve 4, whose windings are electrically controlled by the gun trigger 5. The discharge nozzle 6 is installed at the end of the barrel chamber and its axis makes up an angle α with the axis of the barrel chamber and regulator of this angle 7.

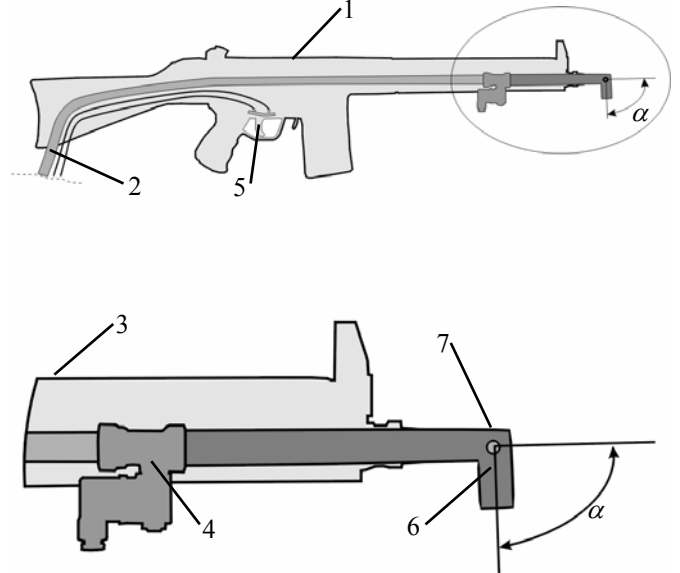

Fig. 3 Scheme of recoil imitation system of the rifle: 1 - rifle; 2 - feeding system of compressed air; 3 - barrel chamber; 4 - electromagnetic valve; 5 - trigger; 6 - discharge nozzle; 7 - position regulator of discharge nozzle

The trainer functions are as follows. Upon pulling the trigger 5, the electromagnetic valve 4, selected as a 2-position normally closed membranous valve for gas, receives feeding and opens the feeding system of compressed air. Then the airflow runs within the chamber of the gun barrel 3 and goes out by impulses via the discharge nozzle 6 to the atmosphere. In this way, the reaction force of the outgoing airflow is used for the imitation of shot recoil. The axis of the discharge nozzle 6 makes the angle α with the axis of the barrel chamber 3, which can be regulated with the nozzle position regulator 7. The required angle α of the gun raise and the maximum value of recoil force are obtained by the type and weight of the gun and axis of determination of the position angle α of the discharge nozzle and the barrel chamber of the gun. Where the trigger is pulled, the system is working in a continuous regime imitating shot series of the automatic gun. Upon changing position of the trigger within a certain period single shots of a gun are imitated.

It should be stressed that the developed recoil imitation system is universal by its technical – operational properties and may be used in the guns of other type, as e.g. M14, M16 etc. A general view of the laser riflemen's trainer is shown in Fig. 4.

A single shots and serial shots in the created laser riflemen trainer are being simulated by means of infrared beams. Having pressed the gun trigger a laser beam or series are being radiated according the command of the control block. Simultaneously the control block activates system of sound simulation and compressed air supply. There-

fore every shot is accompanied by the gun recoil to the rifleman's shoulder and rifleman gets a complete image of battle shooting. Having introduced the developed laser rifleman's trainer the whole process of rifleman's training have been fulfilled-starting from the initial instruction and finishing with the complete training.



a



b



c

Fig. 4 General view of the laser rifleman's trainer: a - fire line; b - target view on the screen; c - information on monitor

4. Experimental investigation

In the second stage the motion of the laser trainer was investigated in an experimental way by single shots and shot series. There were obtained experimental dependencies of the values describing the weapon motion (velocity and displacement) upon time. This allowed the verification of preconditions accepted when theoretically investigating the dynamics of weapon's motion and receiving the parameter values necessary for the synthesis of recoil imitation mechanism.

For this purpose, an experimental stand was developed. The experimental stand consists of a weapon with fixed sensor 4506xyz of the firm *Endevco*. The sensor is fixed to the weapon of the laser trainer. The measurements are made in two directions of axes x and y . *Bruel&Kjaer's* amplifier *Nexus* amplifies the signal received from the sensor. It is also used as a filter removing high frequency noises. Further the signal is transferred to *Bruel&Kjaer's* 4 channel analyzer of vibrations 3560C. The results of measurements are visualized by using *Bruel&Kjaer's* software *Pulse Labshop*.

Fig. 5 represents several charts of the created laser trainer recoil characteristics during a shot and they show the peculiarities of trainer's motion.

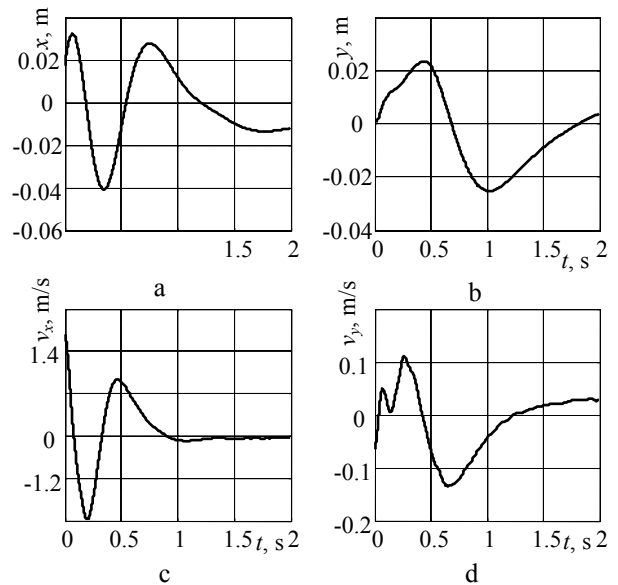

Fig. 5 Imitation of a single shot with the created laser trainer: a - displacement along x axis; b - displacement along y axis; c - velocity along x axis; d - velocity along y axis

4. Conclusions

The laser simulator is an effective aid with excellent prospects in training personnel of the defence system and sportsmen, which comprises a system for transmitting infrared rays, a video receiving system and a computer system for processing. The laser simulator for rifleman's was developed and approved. In order to increase its efficiency it was supplied with mechanisms and systems simulating recoil for single shots and for series of shots as well as for sound.

Forces, which are operating during a shot, were investigated both theoretically and experimentally also recoil parameters were determined. Determined data is

necessary for the dynamic synthesis of recoil simulation mechanisms.

The structural synthesis of the laser simulator for riflemen with full simulation of single shots and series of shots was accomplished, which resulted in creation of a simulator that is successfully used in training riflemen for the national and foreign defence institutions. The results obtained during experimental investigation fully confirm the correctness of theoretical calculations.

References

1. Thales Elektronik Systeme. Sagittarius - Thales Small Arms Trainer. -Thales Training & Simulation. 2004. <http://www.thalesgroup.com/all/pdf/sagittarius.pdf>.
2. **Fats, Inc.** Military - Small Arms Trainer. Fats Virtual Training Solution. 2004. <http://www.fatsinc.com/military/sat/>.
3. **Eli Military Simulation.** Recoil simulation. Eli Military Simulation. 2004. <http://www.eli.ee/index.php?sect=22>.
4. **Kwalwasser, Y.** Recoil Simulator for A Weapon. U.S. Pat. 5,857,854, 1999.
5. **Papakostas S. N., Tsitouras Ch.** High phase-lag order Runge-Kutta and Nystrom pairs. - SIAM J. Sci. Comput., 2000, v.21, p.747-763.
6. **Papakostas, S.N., Tsitouras, Ch.** Cheap error estimation for Runge-Kutta methods.-SIAM.-J. Sci. Comput., 1999, v.20, p.2067-2088.

A. Fedaravičius, M. Ragulskis, E. Sližys

GINKLO ATARANKOS IMITAVIMO SISTEMOS DINAMINĖ SINTEZĖ

Reziumė

Straipsnyje pateiktas automatinio šautuvo AK4 plokščiojo judėjimo atatranksos metu teorinis tyrimas ir ginklo atatranksos imitavimo sistemos, šaudant pavieniais šūviais ir šūvių serijomis, struktūrinė sintezė. Tirtas ginklo plokščiojo judėjimo matematinis modelis sudarytas atsižvelgiant į spynos judėjimą ginklo viduje.

Nustatytos jėgos, veikiančios spyną ir ginklą. Sudarytos ginklo plokščiąjį judėjimą aprašančios diferencialinės lygtys. Sukurta atatranksos imitavimo sistema yra uni-

versali ir gali būti pritaikyta kitiems ginklams, pavyzdžiui: M14, M16 ir t. t.

A. Fedaravičius, M. Ragulskis, E. Sližys

DYNAMIC SYNTHESIS OF THE RECOIL IMITATION SYSTEM OF WEAPONS

S u m m a r y

The article presents a theoretical investigation of planar motion of the automatic weapon AK4 during recoil and constructive synthesis of recoil imitation system with full simulation of single shots and series of shots of the rifle. The investigated mathematical model of planar motion of rifles was created considering movement of bolt inside the rifle.

Was determined the forces impacting the bolt and the rifle. Differential equations of weapons planar motion have been written. The developed recoil imitation system is universal and may be used in the guns of other type, as e.g. M14, M16 etc.

A. Федаравичюс, М. Рагульскис, Э. Слижис

ДИНАМИЧЕСКИЙ СИНТЕЗ СИСТЕМЫ ИМИТАЦИИ ОТДАЧИ ОРУЖИЯ

Резюме

Статья представляет теоретическое исследование плоского движения автоматического оружия АК4 во время отдачи и конструктивный синтез системы имитации отдачи при стрельбе одиночными выстрелами и стрельбе очередями. Исследованная математическая модель плоского движения винтовок была создана, рассматривая движение замка в винтовке.

Определены силы, действующие на замок и винтовку, составлены дифференциальные уравнения плоского движения оружия. Созданная система имитации отдачи универсальна и может быть использована для оружия другого типа, как, например: M14, M16 и т.д.

Received October 21, 2004

DOI: 10.5755/j02.mech.12912