

Orientation of parts on stencil oscillating in horizontal plane

A. Fedaravičius*, B. Bakšys**

*Kaunas University of Technology, Kęstučio 27, LT-44025 Kaunas, Lithuania, E-mail: alfedar@ktu.lt

**Kaunas University of Technology, Kęstučio 27, LT-44025 Kaunas, Lithuania, E-mail: bronius.baksys@ktu.lt

1. Introduction

The stencil method of orientation is the most frequently used for simultaneous orientation of a number of miniature parts. Oscillations of the stencil result in orientation of the parts, which are sliding over the surface of the stencil and fall into its holes when impacted by these oscillations. Orientation of parts when the stencil is oscillating on a vertical plane has been analyzed in the article [1].

For the orientation of miniature fragile parts having easily damageable surfaces it is better to use the stencil oscillating on a horizontal plane. Thus, it is possible to determine the regime of motion of parts as well as recoils from the stencil surface, and this way considerably reduces the dynamic loads acting on the parts being oriented. However, when the parts are moving without recoils, there is a minor possibility of their falling into the holes of the stencil. To increase the efficiency and reliability of orientation of the stencil parts, the stimulating forces are employed. They help the parts on the stencil surface to move in the direction of the holes and fall into them. These stimulating forces are formed by pumping air via the holes of the stencil or by placing constant magnets and electromagnets under the stencil. The action of these forces considerably increases the possibility of falling into the stencil holes.

The process of orientation of the parts, when the stencil is oscillating on a horizontal plane and is influenced by stimulating forces, consists of two stages. First – directed movement of the parts towards the stencil holes

under the influence of vibrations and stimulating force and the second – fall of the parts into the holes due to the effect of stimulating force.

In theoretical aspect, orientation of the parts when the stencil is oscillating in a horizontal plane is close to Zhukovsky's problem [2]. This problem is analyzed at the presence of linear disturbance force. The phase of movement of the parts over the stencil surface in the direction of the holes, where stimulating forces are linear, has been investigated [3]. However, pneumatic and electromagnetic forces influencing the parts depend upon a range and are of non-linear character. Thus, results of the research carried out under the influence of linear stimulating forces are only approximate.

The problems of parts orientation, their insertion into the holes (seats) of stencils by using oscillatory excitation are analyzed in the papers [4, 5]. Here, the main attention is devoted to the investigation of geometrical and energy conditions of the parts falling into the holes. Forces stimulating these parts as well as their influence on the process of orientation have not been analyzed.

This article analyzes orientation of the parts when the stencil is oscillating on a horizontal plane, taking into account non-linear character of stimulating forces.

2. Establishment of stimulating forces

Stimulating forces not only direct the parts towards the holes of the stencil but also orient them (Fig. 1).

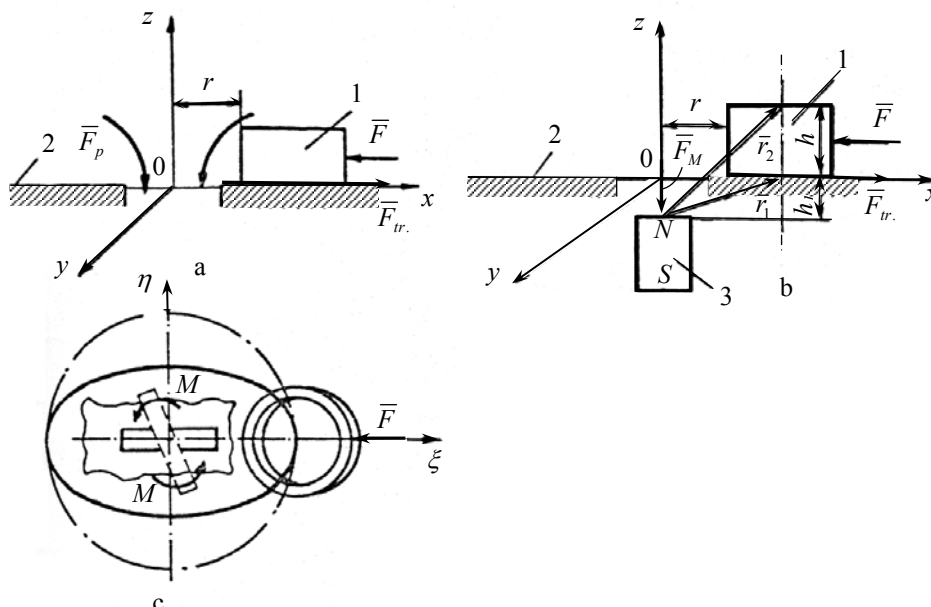

Fig. 1 Charts of orientation of the parts under the impact of stimulating forces: a - pneumatic; b - magnetic; c - turning of the part in respect of the hole

The character of stimulating forces is determined by employing an experimental stand (Fig. 2). The stand consists of a chamber connected with a vacuum pump 1, on the top of which a stencil 2 with a hole is installed. Close to this hole, by elastic element 3 a part 4 is affixed. An elastic element is installed in cart 5, which may be pushed by guide 6 using screw 7. Capacitance sensor is installed at the cart close to the elastic element and it is connected to the measuring equipment 9.

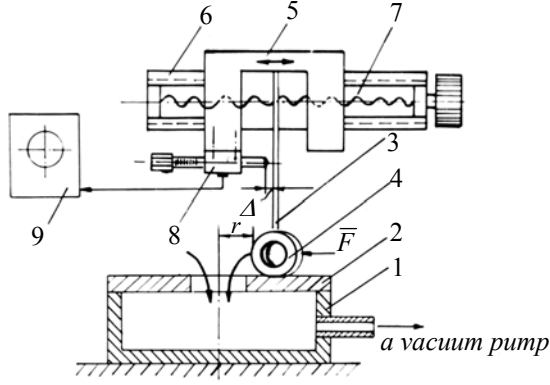

Fig. 2 Experimental stand for the research of stimulating forces

Position of the parts 4 in respect to the stencil hole shall be established by using screw 7. A clearance Δ is formed between elastic element 3 and the capacity sensor. Air is pumped out of chamber 1 and thus suction force F directed towards the stencil hole, impacting part 4, is generated. When this force is active, the elastic element bends towards sensor 8 and this results in clearance Δ change. Its change predetermines capacity change, which is proportional to force F . The stimulating force impacting on the part is predetermined by the distance from the axis of the stencil hole to the part (Fig. 3).

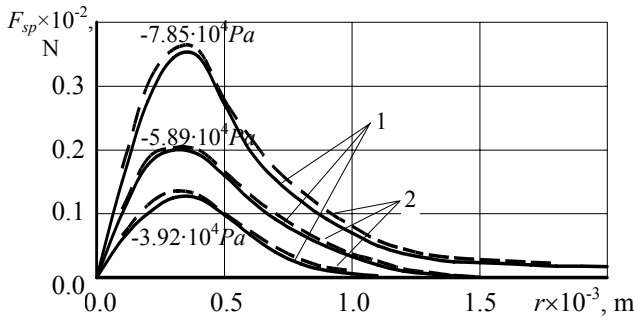

Fig. 3 Dependencies of pneumatic stimulating force F_{sp} upon the part's distance r to the centre of the stencil hole under different vacuum pressure: 1 - experimental; 2 - approximated

Electromagnetic stimulating force impacting the part is determined with the help of the same stand. This force is caused by a rod-type electromagnet, and its value depends on the current in electromagnet coil. The force stimulating the part also depends on its positioning in respect of the stencil hole (Fig. 4).

The charts of both figures show that pneumatic and electromagnetic stimulating forces are non-linear and this should be taken into consideration when analyzing the process of orientation of the parts.

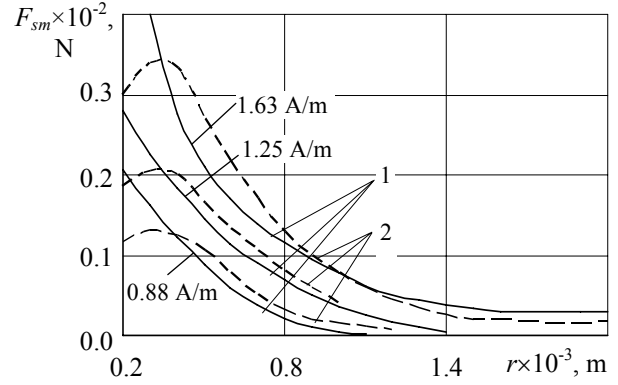

Fig. 4 Dependencies of electromagnetic stimulating force F_{sm} on the part's distance r to the center of the stencil hole, under different strengths of magnetic field: 1 - experimental; 2 - approximated

It has been determined that experimental dependencies of stimulating forces upon the distance between the edge of the part and the center of the stencil hole, may be approximated with sufficient accuracy by using the following function

$$F_s = are^{-cr} \quad (1)$$

here r is distance between the part and the center of the stencil hole; a_{1-3} , c are factors of approximation: $c = 0.33 \cdot 10^4$, $a_1 = 0.31$, $a_2 = 0.18$, $a_3 = 0.14$.

The dependencies of experimental and approximated pneumatic stimulating force F_{sp} upon distance r (Fig. 3) match best. Meantime, the character of dependencies of electromagnetic force F_{sm} upon distance r mainly differs when a part is not far from the center of the stencil hole (Fig. 4). However, such mismatch of experimental and approximated dependencies is not essential in the aspect of orientation of the parts since in this zone the parts are already falling into the hole. Therefore, an expression of approximation of stimulating forces (1) may be used when analyzing motion of the parts in the direction of the stencil holes.

3. Movement of part over the stencil surface

The movement of a part being oriented over the stencil oscillating on a horizontal plane, taking into account pneumatic or magnetic force impact, may be defined by the following equations

$$\begin{cases} \ddot{x} = A\omega^2 \cos \omega t - \mu g \frac{\dot{x}}{\sqrt{\dot{x}^2 + \dot{y}^2}} + P_c \\ \ddot{y} = B\omega^2 \sin \omega t - \mu g \frac{\dot{y}}{\sqrt{\dot{x}^2 + \dot{y}^2}} + P_c \end{cases} \quad (2)$$

here $A\omega^2 \cos \omega t$ and $B\omega^2 \sin \omega t$ is projections of inertia force to the moving axes xOy ; μ is sliding friction factor; g is acceleration of gravity; m is mass of the part; $P_c = F_s / m$. When the part is moving on a plane then

$$\sqrt{\dot{x}^2 + \dot{y}^2} \neq 0.$$

When analyzing the part movement in case of pneumatic stimulation, we shall consider that $\mu = 0.18$. In case of electromagnetic stimulation, the part under orientation is also impacted by vertical component of magnetic stimulating force F_z , therefore $\mu = 0.5$ shall be taken.

The stimulating force has non-linear dependence upon the part position in respect to the center of the hole; therefore analytically it is rather difficult to solve the equation system (2). Movement of the part over an oscillating stencil is analyzed by a numerical method.

It was determined that the trajectories of the part's movement along rectangular coordinates depend on the main parameters of the orientation system:

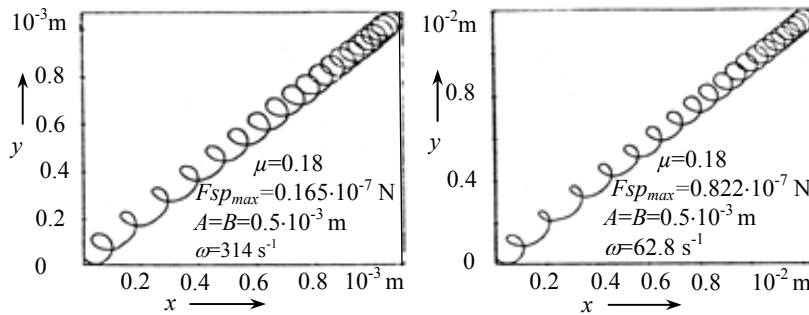

Fig. 5 Trajectories of part movement on plane xy depending on the value of pneumatic stimulating force

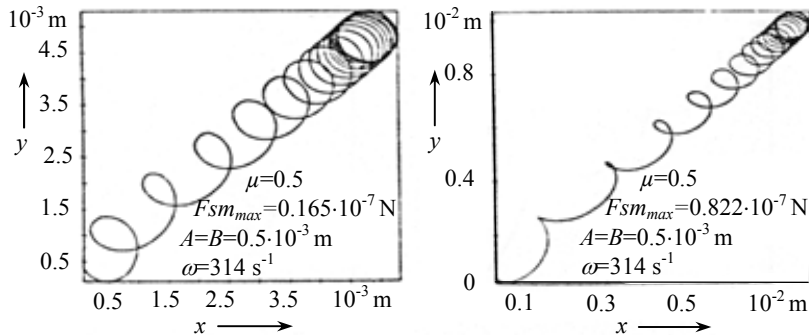

Fig. 6 Trajectories of part movement on plane xy depending on the value of electromagnetic stimulating force

mediate to the edge of the stencil hole. When a part approaches the stencil hole center, the stimulating force and velocity of movement suddenly decrease.

The analysis of part movement on the plane xy and phase trajectories shows that in the case of pneumatic stimulation the part movement starts far more rapidly than in the case of action of the magnetic stimulating force. This results in the conclusion that pneumatic stimulation is more advantageous than magnetic one.

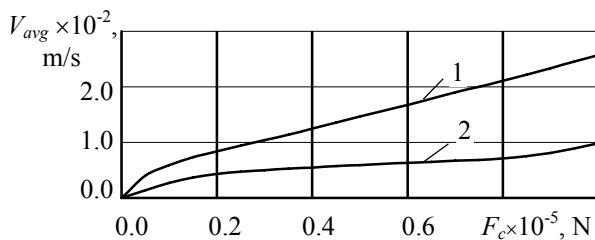

Fig. 7 Dependencies of average velocity of the part on stimulating forces: 1 - pneumatic; 2 - electromagnetic

values of stimulating forces, amplitude and frequency of stencil's oscillations. Samples of these trajectories are given in Figs. 5 and 6.

The result analysis shows that in many cases the trajectory of part movement is a quasi-periodical one, having the form of a stretched spiral, and this spiral coil stretches when approaching the center of the stencil hole. Upon increasing of the stimulating force, spiral form of the trajectory of part movement extends and approaches linear one.

In the majority of cases the velocity of part movement also has a quasi-periodical character and the amplitude of its swings increases when approaching the stencil hole center, and the greatest velocity value is im-

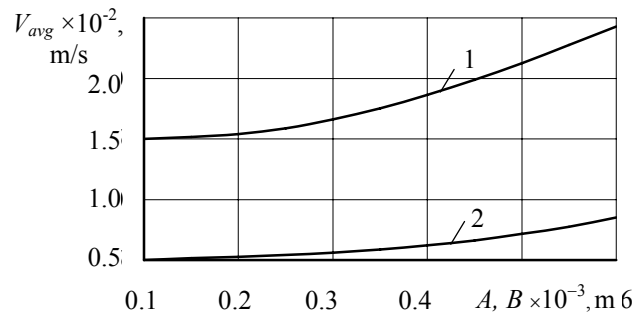

Fig. 8 Dependencies of average velocity of the part on the amplitude of stencil oscillations: 1 - pneumatic stimulating force; 2 - electromagnetic force

The regularities of changes in average velocity of part movement, depending upon parameters of the system under pneumatic and magnetic stimulation, have been analyzed (Figs. 7 - 10).

An average velocity of part movement is nearly directly proportional to the stimulating force and the frequency of stencil oscillations. Meantime, the dependence

upon the amplitude of stencil oscillations is not direct. In all the cases average velocity of part movement is higher under the impact of pneumatic stimulating force. At the increase of the factor of friction between the part and the stencil surface average velocity rapidly decreases. During electromagnetic stimulation the factor of friction is considerably higher. Thus, pneumatic stimulation is more efficient than electromagnetic one.

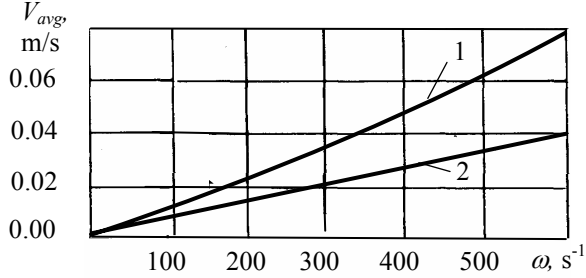

Fig. 9 Dependencies of average velocity of the part on the frequency of stencil excitation: 1 - pneumatic stimulating force; 2 - electromagnetic force

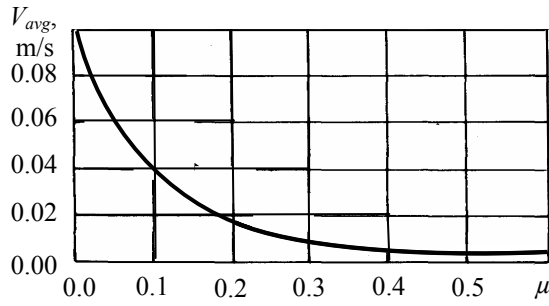

Fig. 10 Dependency of average velocity of the part on friction factor

4. Falling of part into hole

After the first phase of part orientation, its shift to the stencil hole zone, when impacted by stimulating force, contours of the part and stencil hole are superposed and the part falls into the hole.

If parts are being orientated when the stencil is oscillating on a horizontal plane, like in the case when it is oscillating on a vertical plane, after exceeding the set amplitudes of oscillation and frequency, the holes of the stencil ostensibly shrink. This prevents the parts from falling into the holes of the stencil.

Charts of the part falling into the stencil hole are given in Fig. 11.

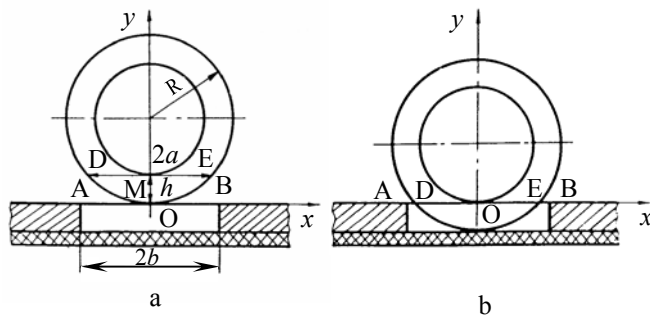

Fig. 11 Charts of the part falling into the holes of horizontally oscillating stencil: a - prior to the part falling; b - after the part falling into the hole

The stencil is oscillating in the direction of axis x according to the harmonic law

$$x(t) = A \sin \omega t + x_0 \quad (3)$$

here A , ω are amplitude and frequency of stencil oscillations, x_0 is stencil point coordinate.

The coordinate origin divides the stencil hole AB into two equal parts, and the part, being above the hole, touches axis x by its bottom side and falls down at the velocity v .

The part will completely fall into the stencil hole only when it descends by the height of its wall h lower axis x without encountering the edges of the stencil hole A or B before that.

Coordinates of points M, A and B shall be marked: x , y ; x_A , x_B respectively.

Initial conditions of part movement

$$\left. \begin{aligned} x_0 &= 0 \\ y_0 &= h \end{aligned} \right\} \quad (4)$$

$$\left. \begin{aligned} \dot{x}_0 &= 0 \\ \dot{y}_0 &= v \end{aligned} \right\} \quad (5)$$

$$\left. \begin{aligned} x_A &= -b \\ x_B &= b \end{aligned} \right\} \quad (6)$$

Taking into consideration initial conditions (6), the differential equations of movement of the stencil edges A and B are

$$\left. \begin{aligned} x_A &= A \sin \omega t - b \\ x_B &= A \sin \omega t + b \end{aligned} \right\} \quad (7)$$

Equations of movement of the part

$$\left. \begin{aligned} m\ddot{x} &= 0 \\ m\ddot{y} &= mg \end{aligned} \right\} \quad (8)$$

Having integrated these equations, and taking into account initial conditions (4) and (5), the following is obtained

$$x = 0; \quad y = -\frac{gt^2}{2} - vt + h \quad (9)$$

When $t = t_2$, part's point M is on the axis x . Thus, $y(t_2) = 0$. The following is determined from (9)

$$y(t_2) = -\frac{gt_2^2}{2} - vt_2 + h = 0$$

or

$$t_2 = \frac{-v + \sqrt{v^2 + 2gh}}{g} \quad (10)$$

Condition of the part falling into the stencil hole

$$\left. \begin{array}{l} x_A < x_D \\ x_B > x_E \end{array} \right\} \quad (11)$$

here x_D and x_E are abscissas of points D and E (Fig. 11).

Then

$$\left. \begin{array}{l} x_D = -\sqrt{R^2 - (R - h + y(t))^2} \\ x_E = \sqrt{R^2 - (R + h + y(t))^2} \end{array} \right\} \quad (12)$$

here $y(t)$ is calculated from equation (9).

Inequalities (11), taking into account expressions (7), can be written as follows

$$\left. \begin{array}{l} A \sin \omega t - b < -\sqrt{R^2 - (R - h + y(t))^2} \\ A \sin \omega t + b > \sqrt{R^2 - (R - h + y(t))^2} \end{array} \right\} \quad (13)$$

The following is obtained from dependencies (4) and (10)

$$\left. \begin{array}{l} \sqrt{R^2 - (R - h + y(t_0))^2} = 0 \\ \sqrt{R^2 - (R - h + y(t_2))^2} = a_0 \end{array} \right\}$$

here $a_0 = \sqrt{2Rh - h^2}$.

Thus, inequalities (13) are met under any velocity v , when $A < b - a$.

As a rule, when the stencil being oriented is oscillating on a horizontal plane, $A > b - a$.

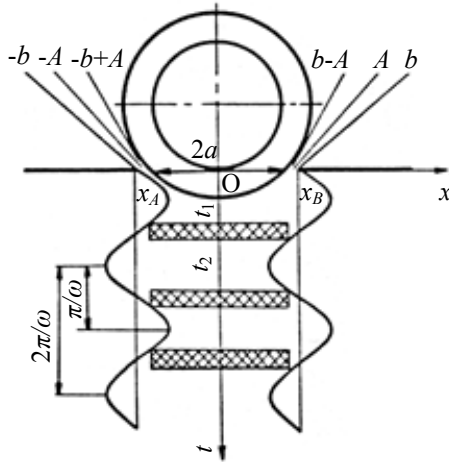

Fig. 12 Chart of part movement inside the stencil hole

From graphically depicted inequalities (13) (Fig. 12) it is obtained, that until the moment t_1 , when

$$\left. \begin{array}{l} x_E(t_1) = \sqrt{R^2 - (R - h + y(t_1))^2} = b - A \\ x_D(t_1) = \sqrt{R^2 - (R - h + y(t_1))^2} = b + A \end{array} \right\} \quad (14)$$

expressions (14) are equivalent.

The time period $[t_1, t_2]$ is analyzed. The time moment t_1 is determined from dependency (14). The

change of edges of the stencil hole x_A and x_B within one period $2\pi/\omega$ show, that conditions (13) are met when $[t_1, t_2]$ comes into one of the cross-hatched areas

$$x_B > a; \quad x_A < a$$

Duration of the part shift from $b - A$ to a

$$\tau = \frac{2\varphi_0}{\omega} \quad (15)$$

Here the angle of phases is determined from the dependence

$$A \sin \varphi_0 = b - a \quad (16)$$

Velocity of the part must be such that during the time τ it could shift by the range $(b - A) - a$, i.e.

$$t_2 - t_1 \leq \tau \quad (17)$$

From (6 - 10) and (13 - 17) the allowable frequency of stencil oscillations is calculated

$$\omega = \frac{2g \arcsin[(b - a)/A]}{\sqrt{v^2 + 2gh - \sqrt{v^2 + 2g[R^2 - (b - A)^2]}}} \quad (18)$$

By employing numerical method, it was determined that the allowable frequency of stencil oscillations decreases upon the increase of their amplitude (Fig. 13). But the allowable frequency may be considerably increased at higher velocity of the part falling into the hole. This velocity is higher when parts are impacted by stimulating forces. In this way, stimulating forces help the part to move in the direction of the stencil hole as well as to fall into the hole.

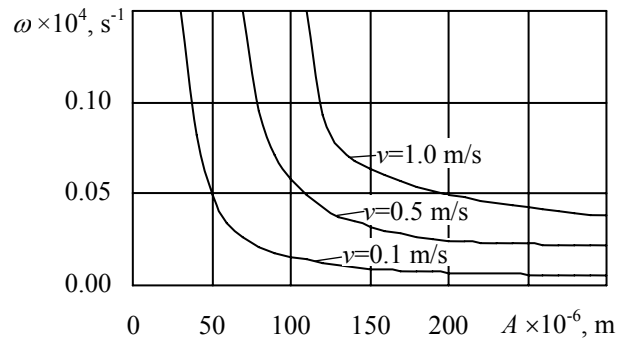

Fig. 13 Dependencies of allowable frequency of oscillations upon the amplitude of stencil oscillations and velocity of the parts falling into the hole

To check the dynamic and mathematical models as well as calculation results, experimental tests of the stencil orientation of the parts were carried out. A high-speed camera recorded the trajectory of part movement and its falling into the hole of the stencil in cases of pneumatic and magnetic stimulation. It became apparent that the calculated and experimentally determined movement trajectories of the part coincide. From the filmogram it was determined that in the case of pneumatic stimulation the parts

start moving when the stencil oscillations emerge. Meantime, magnetically stimulated parts, in the first phase, are moving along nearly a close circular or elliptical trajectory, and later start moving intensely and purposefully. This increases the duration of orientation and confirms the theoretically established fact that pneumatic stimulation is more efficient than magnetic one.

5. Conclusions

1. Stencil orientation of the parts under the influence of stimulating forces, when the stencil is oscillating along elliptical trajectory on a horizontal plane, has been researched. It was determined that pneumatic and electromagnetic stimulating forces are non-linear and depend upon the distance between the part and the center of the stencil hole.

2. It was determined that the trajectory of the part movement and its velocity over the stencil surface when influenced by non-linear stimulating force, is of quasi-periodical character and has the form of a stretched spiral. An average velocity is nearly directly proportional to the stimulating force and the frequency of stencil oscillations.

3. In the case of pneumatic stimulation, the movement of the part in the direction of the stencil hole starts far more rapidly than when impacted by magnetic stimulating force. Consequently, pneumatic stimulation is more advantageous than magnetic one.

4. The allowable frequency of stencil oscillations, when the part still can fall into the hole of the stencil, was calculated. When the amplitude of oscillations is increasing the allowable frequency of oscillations is decreasing. When the velocity of the part falling into the hole is greater, the allowable frequency may be considerably increased.

References

1. **Fedaravičius, A., Bakšys, B., Rudgalvienė, N.** Orienting of parts when stencil is vibrating in vertical plane. -Mechanika. -Kaunas: Technologija, 2004, No6 (50), p.44-49.
2. Вибрации в технике. Справочник в 6 томах. Вибрационные процессы и машины, -Москва: Машиностроение, 1981. т.4.-509с.
3. **Иванов, И.И.** Проектирование систем автоматического манипулирования миниатюрными изделиями.-Москва: Машиностроение, 1981.-271с.
4. **Moncevicz, P.H., Jakiela, M.I., Ulrich, K.T.** Orientation and insertion of randomly presented parts using vibratory agitation.- ASME 3rd Conference of flexible assembly systems, 1991, v.33, p.41-47.
5. **Krishnasamy, J., Jakiela, M.I., Whitney, D.E.** Mechanics of vibration-assisted entrapment with application to design.-Proceedings of the IEEE Int. con. on robotics and automation.- Mineapolis, Minnesota USA, 1996, p.838-845.

A. Fedaravičius, B. Bakšys

DETALIŲ ORIENTAVIMAS TRAFARETUI VIRPANT HORIZONTALIOJOJE PLOKŠTUMOJE

Reziumė

Išnagrinėtas detalių orientavimas, kai trafaretas virpa horizontaliojoje plokštumoje ir jas veikia stimuliuojančios jėgos. Ištirti detalių judėjimo prie trafareto skylių ir jų įkritimo etapai. Nustatytos judėjimo vidutinio greičio priklausomybės nuo stimuliuojančios jėgos, trafareto virpesių amplitudės, žadinimo dažnio, trinties koeficiento. Gauta išraiška leistinajam trafareto virpesių dažniui apskaičiuoti. Sudarytos leistinojo virpesių dažnio priklausomybės nuo virpesių amplitudės ir detalių įkritimo greičio.

A. Fedaravičius, B. Bakšys

ORIENTATION OF PARTS ON STENCIL OSCILLATING IN HORIZONTAL PLANE

Summary

Orientation of parts when a stencil is oscillating in horizontal plane and these parts are impacted by stimulating forces is analyzed. The phases of parts movement towards the stencil holes and their falling into the holes was researched. The dependencies of an average velocity of movement under the impact of stimulating force, amplitude of stencil oscillations, excitation frequency and the factor of friction were determined. The expression to calculate allowable frequency of stencil oscillations was obtained. The dependencies of allowable frequency of oscillations upon oscillations amplitude and velocity of the part falling into holes were formed.

A. Федаравичюс, Б. Бакшис

ОРИЕНТИРОВАНИЕ ДЕТАЛЕЙ ПРИ КОЛЕБАНИИ ТРАФАРЕТА В ГОРИЗОНТАЛЬНОЙ ПЛОСКОСТИ

Резюме

Рассмотрено ориентирование деталей при действии на них стимулирующих сил и колебаний трафарета в горизонтальной плоскости. Исследованы этапы перемещения деталей к отверстиям трафарета и их западания. Определены зависимости средней скорости перемещения от стимулирующей силы, амплитуды вибраций трафарета, амплитуды возбуждения, коэффициента трения. Получено выражение для определения допустимой частоты вибраций трафарета. Построены зависимости допустимой частоты вибраций от амплитуды вибраций и скорости западания деталей.

Received November 24, 2004

DOI: 10.5755/j02.mech.12966