

Stresses and strains determination of welded pipelines with the mild interlayer at plane stress state under elastic-plastic loading

V. Kaminskas*, A. Bražėnas**

*Kaunas University of Technology, Daukanto 12, LT-35212 Panevėžys, Lithuania, E-mail: vkaminskas@ekmecha.lt

**Kaunas University of Technology, Daukanto 12, LT-35212 Panevėžys, Lithuania, E-mail: mechkat@midi.ppf.ktu.lt

1. Introduction

A great number of welded joints show higher or lower heterogeneity of mechanical properties of their separate zones. Zone which strength properties is lower than these of the base metal (mild interlayer) may be mild metal of weld, thermal effect zone and decarburized layer. At axial elastic-plastic loading of the welded pipe mild interlayer strongly effects strength of the welded joint [1].

Stress strain state components of welded pipelines and fatigue lifetime of welded pressure vessels were investigated in work [2] by FEM. The stress state of pipe subjected to internal pressure p at plane strain state an elastic-plastic loading is analyzed work [3]. But analytical stress strain determination for mechanically heterogeneous welded pipelines under elastic-plastic loading is not known up till now.

The stresses and strain determination in a welded pipeline with a mild square interlayer under elastic-plastic loading, when in cross-sections interaction of metal H and mild metal M disappears and plane state realizes, is analyzed in this paper. Strain distribution in the pipe wall is determined from approximated Lamé's equations by estimating interaction at the contact plane materials M and H (fusion line). Elastic-plastic strains appear in mild metal at internal surface of the pipe. When internal pressure p increases elasto-plastically deformed zone extends on the external radius direction.

2. Stress strain state of welded joint at elastic and elastic-plastic loading

Calculations of stress strain state of mechanically heterogeneous welded pipelines with a ring cross-section subjected to pressure are performed in relative dimensionless coordinates [4] $\eta^H = z/r_{in}$, $\eta^M = -z/r_{in}$, $\rho = r/r_{in} = 1 + \xi s$ by using parameters: the relative height of mild interlayer $\alpha^M = h/r_{in}$; the relative thickness of pipes wall $s = \delta/r_{in}$; coordinate of the wall relative thickness $\xi = (\rho - 1)/s$; the relative distance from contact plane $\alpha^H = l_r/r_{in}$ in which interaction of materials H and M disappears; where δ is thickness of the pipes wall (Fig. 1).

In this case the theory of small elastic-plastic deformation was used and are accepted these principle assumptions:

- residual stresses are abolished by heat treatment;
- material is incompressible at elastic and elastic-plastic straining ($e_r + e_\theta + e_z = 0$, $\nu = \nu^H = \nu^M = 0.5$);
- modulus of elasticity of both materials are equal ($E = E^H = E^M$).

At elastic loading (when $\sigma_{i\max}^M \leq \sigma_e^M$) stresses of welded joint may be determined by Lamé's equation [4], which may be expressed on dimensionless coordinates, when p is internal pressure:

$$\left. \begin{matrix} \sigma_r^L(\xi) \\ \sigma_\theta^L(\xi) \end{matrix} \right\} = \frac{p}{s(2+s)} \left(1 \mp \frac{(1+s)^2}{(1+\xi s)^2} \right) \quad (1)$$

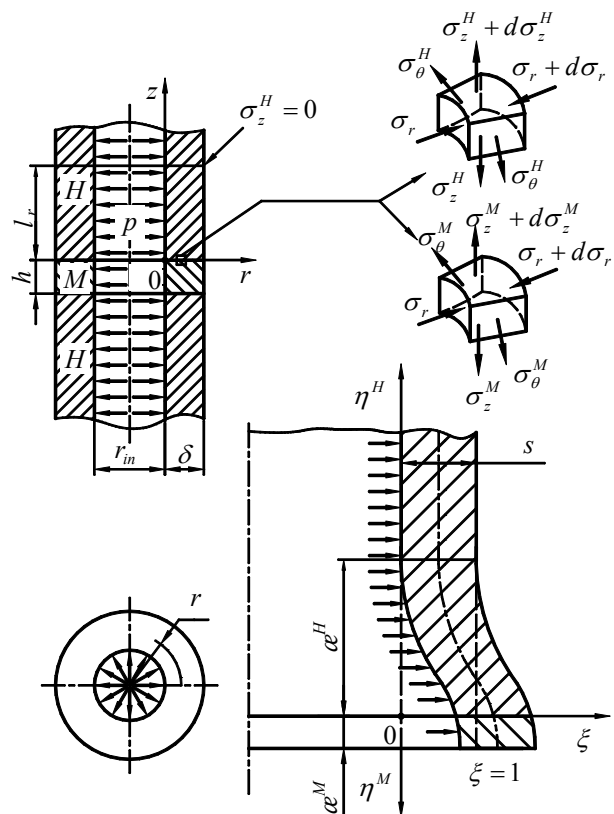

Fig. 1 Scheme for stress strain state determination in welded pipe with the mild interlayer

The relative thickness of majority pipeline systems $s \leq 0.2 - 0.3$. In this case stresses and strains on the

^M upper index denotes the value in mild weld metal

^H upper index denotes the value in hard pipe metal

^L upper index denotes the values calculated by Lamé's equations

thickness of pipe wall are distributed approximately linearly. Then

$$\sigma_r(\xi) = -p(1-\xi) \quad (2)$$

Lame's diagram of stress σ_θ is approximated by two linear functions $f_1(\xi, s)$ in the interval $0 \leq \xi \leq 0.5$ and $f_2(\xi, s)$ in $-0.5 < \xi \leq 1$, when $\sigma_\theta(0) = \sigma_\theta^L(0)$, $\sigma_\theta(1) = \sigma_\theta^L(1)$ (Fig. 2). It is accepted that $\sigma_\theta(0.5) = \sigma_{\theta m}^L = \int_0^1 \sigma_\theta^L d\xi = p/s$ is the mean value of σ_θ .

Then

$$\sigma_\theta(\xi) = p \left[\frac{1}{s} - B(\xi - 0.5) \right] \quad (3)$$

where $B = B_1 = 2(s+1)/(s+2)$, when $\xi \leq 0.5$ and $B = B_2 = 2/(s+2)$, when $\xi > 0.5$.

Strains $e_\theta(\xi)$, $e_r(\xi)$ and $e_z(\xi)$ the most convenient to calculate by using the circumference strain value $e_\theta(0.5) = e_\theta^e(0.5)$. Strain $e_\theta^e(0.5) = \frac{p(1+0.25s)}{E s}$ is calculated from Hooke's law when $\sigma_z = 0$ and $\xi = 0.5$.

In further calculations the circumference strain e_θ is determined by using its value when $\xi = 0.5$.

Stress intensity at axial symmetrical deformation at plane strain state $\sigma_i = \sqrt{\sigma_r^2 + \sigma_\theta^2} - \sigma_r \sigma_\theta$. Then by estimating Eqs. (2), (3) is obtained

$$\sigma_i(\xi) = p \sqrt{(1-\xi)^2 + \left[\frac{1}{s} - B(\xi - 0.5) \right]^2} + (1-\xi) \left[\frac{1}{s} - B(\xi - 0.5) \right] \quad (4)$$

Maximum value of pressure p at elastic loading under plane stress state in a mild metal may be determined by Eq. (4) from condition $\sigma_i^M(0) \leq \sigma_e^M$, when $\xi = 0$, then

$$p_{e_{max}}^M < \sigma_e^M / \sqrt{1 + \left(\frac{1}{s} - 0.5B \right)^2 + \frac{1}{s} - 0.5B} \quad (5)$$

where σ_e is the limit of elasticity.

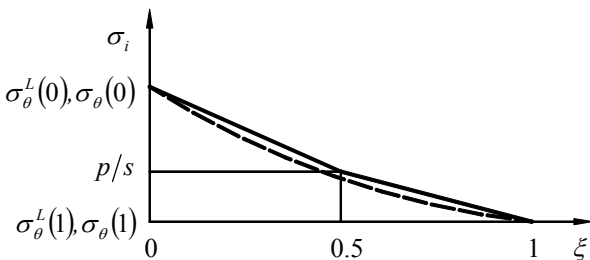

Fig. 2 Scheme of stress σ_θ diagram approximation

From Eq. (5) follows that elastic-plastic stress strain state appears at internal surface of mild metal when $p > p_{e_{max}}^M$.

Strain distribution at elastic-plastic loading depends on elastic-plastically deformed zone $0 \leq \xi \leq \xi_p$. Pressure which corresponds elastic-plastic deforming in this zone may be determined from Eq. (4) by accepting $\sigma_i(\xi) = \sigma_e$ and choosing coordinate $\xi = \xi_p$, then

$$p_p = \sigma_e / \sqrt{\left[\frac{1}{s} + B(\xi_p - 0.5) \right]^2 + (1-\xi_p)^2} + (1-\xi_p) \left[\frac{1}{s} + B(\xi_p - 0.5) \right] \quad (6)$$

Strain state at the elastic-plastic loading of mild metal at the contact plane is determined from condition $e_\theta^{M*} = e_\theta^{H*}$ and $e_i^{M*} = e_i^{H*}$. The most convenient way for stress strain state calculation at elastic-plastic loading is obtained when strains e_r and e_z are determined from the presumption that ratio $K_e(0.5) = e^e(0.5)/e_\theta^e(0.5)$ at elastic and elastic-plastic loading is the same, then

$$e(0.5) = e_\theta(0.5) K_e(0.5) \quad (7)$$

where $e_r^e(0.5)$, $e_z^e(0.5)$ are elastic strains of hard metal, calculated from Hooke's law when $p \leq p_{e_{max}}^M$ and $\sigma_z = 0$: $K_{e_r}(0.5) = -(1+s)/(2+0.5s)$ and $K_{e_z}(0.5) = -(1+0.5s)/(2+0.5s)$. Strains $e_\theta(\xi)$, $e_r(\xi)$ and $e_z(\xi)$ are determined in the same manner as $e(0.5)$, then

$$e(\xi) = e(0.5) [e^e(\xi)/e^e(0.5)] = e(0.5) \cdot K_e(\xi) \quad (8)$$

where $e^e(\xi)$ are strains $e_\theta^e(\xi)$, $e_r^e(\xi)$ and $e_z^e(\xi)$ calculated by Hooke's law when $\sigma_z = 0$; ratios

$$K_{e_\theta}(\xi) = 2 \frac{s(1-\xi) + 2 + Bs(1-2\xi)}{s+4}$$

$$K_{e_r}(\xi) = \frac{4s(1-\xi) + 2 + Bs(1-2\xi)}{2(s+1)}$$

$$K_{e_z}(\xi) = \frac{2s(1-\xi) - 2 - Bs(1-2\xi)}{s-2}$$

Eq. (8) also maybe used for elastic strains $e^e(\xi)$ calculation.

At elastic-plastic loading $\sigma_i = f(e_i)$. Therefore strain intensity $e_i(\xi)$, $\sigma_i(\xi)$ and stress σ_θ in cross-section η are determined in such manner:

- stress intensity is determined by the equation

$$e_i(\xi) = e_\theta(\xi) K_i(\xi) \quad (9)$$

* upper index denotes the values of the contact plane

where $K_i(\xi) = \frac{e_i(\xi)}{e_\theta(\xi)}$

$$= \sqrt{\frac{\left[\frac{1}{s} + B(\xi - 0.5)\right]^2 + (1 - \xi)^2 + (1 - \xi) \left[\frac{1}{s} + B(\xi - 0.5)\right]}{\frac{1}{s} + B(\xi - 0.5) + 0.5(1 - \xi)}};$$

- stress intensity is calculated from the equations

$$\left. \begin{aligned} \sigma_i &= E e_i, \text{ when } e_i \leq e_e \\ \sigma_i &= \sigma_e \left(\frac{e_i}{e_e} \right)^m, \text{ when } e_i > e_e \end{aligned} \right\} \quad (10)$$

when tensile curve at elastic-plastic zone is approximated by power function (m is power index of the material hardening in elastic-plastic zone);

- stress

$$\sigma_\theta = 0.5 \left(\sigma_r + \sqrt{4\sigma_i^2 - 3\sigma_r^2} \right) \quad (11)$$

- secant modulus of stress strain curve

$$E'(\xi) = \sigma_i(\xi) / e_i(\xi) \quad (12)$$

is determined when $\sigma_i > \sigma_e$, where e_e is strain which corresponds to σ_e .

Strain e_θ^* depends on elasto-plastically deformed zone $0 \leq \xi \leq \xi_p$. When the last point of its zone of mild metal $\xi_p^M \leq 0.5$ parameters of mechanical heterogeneity of weld joint $\gamma_N = \sigma_i^{H*}(0.5) / \sigma_i^{M*}(0.5) = 1$ (Fig. 3). The pressure p_{pc}^M which corresponds $\xi_p^M = \xi_{pc}^M = 0.5$ is determined from Eq. (6) by accepting $\sigma_e = \sigma_e^M$ and $\xi_p^M = 0.5$. In this case $e_\theta^*(0.5) = e_\theta^{H*}(0.5) = e_\theta^H(0.5)_{\eta^H = \omega^H}$ may be calculated from dependence

$$e_\theta^{H*}(0.5)_{\eta^H = \omega^H} = \bar{u} \frac{r_{in}}{r_{in}(1 + 0.5s)} = \frac{p(1 + 0.25s)}{sE}, \quad \text{where}$$

$$\bar{u} = e_\theta(0.5)\rho(0.5) \text{ is relative displacement of hard metal at}$$

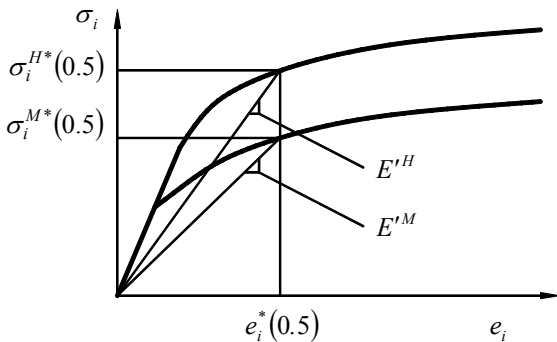

Fig. 3 Relationship between stress and strain intensities and scheme for determination of secant modulus and heterogeneity of welded joint

longitudinal section $\xi = 0.5$ when $\rho = \rho_m = 1 + 0.5s$.

When $p > p_p^M$ the parameter of mechanical heterogeneity $\gamma_N > 1$, in this case strain $e_\theta^H(0.5)$ increases due to deviation axis of the pipe wall which appears because of interaction of materials M and H at the contact plane [4]. This deviation and strain $e_\theta(0.5, \eta)$ is increased with increasing γ_N . Because γ_N depends on strain e_θ distribution of its value must be determined by approaching method.

Maximum pressure $p_{e_{max}}^H$ when $\sigma_i^H(0) = \sigma_e^H$ is determined from Eq. (5) by substituting σ_e^H instead of σ_e^M . When $p > p_{e_{max}}^H$ at the internal point elastic-plastic deforming of H metal begins. In this case $e_\theta^H(0.5) = e_\theta^e(0.5)$ value is decreased because it was determined when material H was deformed elastically.

Strain $e_\theta^{(0)}(0.5)$ may be determined from Eq. (8). Value $e_\theta^{H(0)}(0.5)$ may be corrected from integral equilibrium condition $\sigma_{\theta m}^H = \sigma_{\theta m}^{H(0)}(0.5)$, where

$$\sigma_{\theta m}^H = \int_0^1 \sigma_\theta^H d\xi = \int_0^{\xi_p^H} \sigma_\theta^H d\xi + \frac{\sigma_\theta^H(\xi_p^H) + \frac{P}{s}}{2} (0.5 - \xi_p^H) + 0.25 p \left[\frac{1}{s} + \left(\frac{1}{s} - 0.5 B_2 \right) \right] \quad (13)$$

is mean value of circumference stress in the thickness of $\xi = 0.5$. Maximum coordinate ξ_p^H which corresponds the finite point at elasto-plastically deformed zone of material H is determined from Eq. (6), when $\sigma_i^H(\xi_p^H) = \sigma_e^H$, then

$$\xi_p^H = \frac{-b - \sqrt{b^2 - 4ac}}{2a}, \quad \text{where } a = B_1^2 + B_1 + 1; \quad b = -[2 + B_1^2 + 1.5B_1 + \frac{1}{s}(1 + 2B_1)]; \quad c = 1 + \frac{1}{s^2} + 0.5B_1 + 0.25B_1^2 + \frac{1}{s}(1 + B_1) - \left(\frac{\sigma_e}{p_e^H} \right)^2 \quad (\text{in this case pressure } p > p_{e_{max}}^H).$$

Corrected value of circumference strain $e_\theta^{H(1)}$ at the distance ω^H from contact plane is determined from Hooke's law, by using $\sigma_\theta^H(0.5) = \sigma_\theta^{H(0)}(0.5) + \Delta A_{\sigma\theta}$ instead of $\sigma_\theta^{H(0)}(0.5)$ where $\Delta A_{\sigma\theta} = \sigma_\theta^{H(0)}(0.5) - \sigma_{\theta m}^H$ and $\sigma_z = 0$. Calculation may be simplified by assuming linear stress σ_θ^H distribution at elastic-plastic zone ($0 \leq \xi \leq \xi_p^H$). Then $\Delta A_{\sigma\theta} \approx 0.5 [\sigma_\theta^{H(0)}(0) - \sigma_\theta^H(0)] \xi_p^H$ and $\sigma_\theta^H(0.5) = \sigma_\theta^{H(0)}(0.5) + \Delta A_{\sigma\theta} / (1 - 0.5 \xi_p^H)$, where stress value $\sigma_\theta^{H(0)}(0)$ is determined from Eqs. (7) – (11) (Fig. 4).

Expression for calculating circumference strains at axial symmetrical deformation of mechanically heterogeneous welded pipelines under elastic-plastic

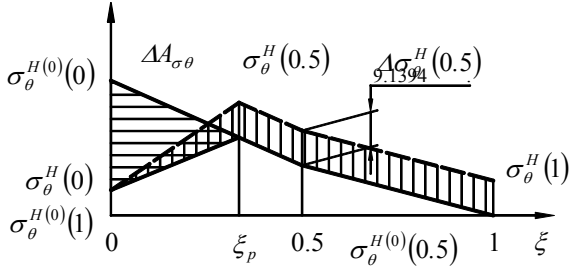

Fig. 4 Scheme for determination $\sigma_\theta^H(0.5)$ at elastic-plastic loading of metal H

loading in longitudinal section $\xi = 0.5$ in dimensionless coordinate system when $\gamma_N = \sigma_i^{H*}(0.5)/\sigma_i^{M*}(0.5) > 1$ (Fig. 3)

$$e_\theta^H(0.5, \eta^H) = e_\theta^H(0.5) \left\{ \exp(-k\eta^H) \times [C_1 \sin(k\eta^H) + C_2 \cos(k\eta^H)] + 1 \right\} \quad (14)$$

$$e_\theta^M(0.5, \eta^M) = e_\theta^H(0.5) \left\{ \exp(-k\eta^M) \times [C_3 \sin(k\eta^M) + C_4 \cos(k\eta^M)] + 1 \right\} \quad (15)$$

was determined in works [3 - 6], where $k = \sqrt{\frac{3(1-\nu^2)}{(1+0.5s)^2 s^2}}$

is relative stiffness of the pipe wall; $\alpha^H \approx \frac{3\pi}{2k}$ is the distance from the contact plane in which the interaction of M and H metals disappears in base metal [4, 5] (distribution of relative distance α^H dependent on s is shown in Fig.(5)); coefficients C_1, C_2, C_3 and C_4 are

$$C_1 = C_3 + 2C_4 \quad (16)$$

$$C_2 = C_4 \quad (17)$$

$$C_3 = \frac{\sin(\alpha^M k) + \cos(\alpha^M k)}{\sin(\alpha^M k) - \cos(\alpha^M k)} C_4 \quad (18)$$

$$C_4 = \frac{\alpha^M k \times \dots}{\gamma_N [\cos(\alpha^M k) \cos(\alpha^H k) - \dots \times (\gamma_N - 1) \times \dots - 2 \sin(\alpha^M k) \cos(\alpha^H k) - \sin(\alpha^M k) \sin(\alpha^H k) - \dots \times \exp(\alpha^H k) \times \dots - \cos(\alpha^M k) \exp(\alpha^H k) + 2 \sin(\alpha^M k) \exp(\alpha^H k)] - \dots \times [\sin(\alpha^M k) - \cos(\alpha^M k)] \dots - \cos(\alpha^M k) \exp(\alpha^H k) + \exp[(\alpha^H - \alpha^M)k]} \quad (19)$$

In work [4] stress strain state of mechanically heterogeneous welded joint is analyzed at elastic loading when $\gamma_N = \text{const}$. Because at elastic-plastic straining of mechanically heterogeneity welded pipelines the parameter of heterogeneity of welded joint depends on $e_i^*(0.5)$, therefore γ_N and circumference strain $e_\theta(0.5)$, when

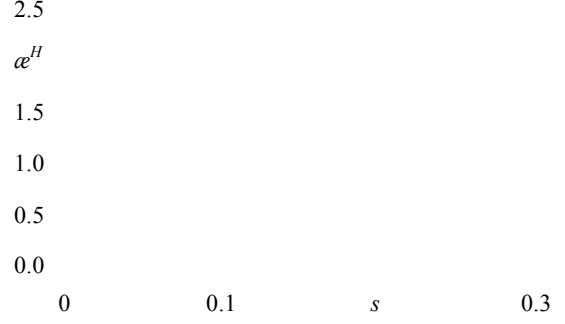

Fig. 5 Dependence α^H on relative thickness of the pipe wall

$p > p_{pc}$ are determined by approaching method in such a way:

- at initial approaching it was assumed that $e_\theta^*(0.5) = e_\theta^{H'}(0.5)$;
- $\sigma_i^{H'}(0.5)$ and $\sigma_i^{M*}(0.5)$ are determined from Eqs. (7), (8) and (10);
- $\gamma_N^{(0)} = \sigma_i^{H'}(0.5)/\sigma_i^{M*}(0.5)$;
- $e_\theta^*(0.5) = e_\theta^{H'}(0.5)(C_4 + 1)$ is determined from Eq. (14);
- $e_i^*(0.5)$, $\sigma_i^{H*(j)}(0.5)$, $\sigma_i^{M*(j)}(0.5)$ are determined from Eqs. (9) and (10);
- by Eq. (15) and the condition that on the contact plane displacements of base and mild metals are equal $\gamma_N^{(j)} = \sigma_i^{H*(j)}(0.5)/\sigma_i^{M*(j)}(0.5)$ is calculated.

Approaching process is continued up till when $\left| \left(\gamma_N^{(j)} - \gamma_N^{(j-1)} \right) / \gamma_N^{(j)} \right|$ becomes desirably small (for accuracy 0.1 % usually is needed 3–5 iterations).

When $\gamma_N > 1$ there are longitudinal stresses σ_z are on inner and outer surface of the pipe because bending moment acts [5]. Expression of σ_{zmax} obtained in work [4] may be written in relative parameters, then at elastic loading

$$\sigma_{zmax} = \pm \frac{6\bar{M}_z}{s^2} = \frac{4E}{3} \left(\pm \frac{s}{2} \frac{d^2 \bar{u}(\eta)}{d\eta^2} \right) \quad (20)$$

where $\bar{M} = M/r_{in}^2$; $\bar{u} = (1+0.5s)e_\theta(0.5)$

Bending moment M_z appears due to the interaction of H and M materials under elastic-plastic loading, then from Eq. (20) longitudinal stresses of base metal H

$$\sigma_z(\xi, \eta^H) = \frac{4E^H}{3} s(0.5 - \xi) \times (1 + 0.5s) \frac{d^2 e_\theta^H(0.5, \eta^H)}{(d\eta^H)^2} \quad (21)$$

Because $\frac{d^2 e^H(0.5, \eta^H)}{(d\eta^H)^2} \neq \frac{d^2 e^M(0.5, \eta^M)}{(d\eta^M)^2}$, $e^M \ll e^H$ and $e_\theta^H(0.5, \eta^M) \approx e_\theta^M(0.5, \eta^M)$ longitudinal stresses of mild metal M are calculated in the same manner as longitudinal stresses of H metal by accepting

$$\sigma_z(\xi, \eta^M) = \frac{4E'^M}{3} s(0.5 - \xi) \times (1 + 0.5s) \frac{d^2 e_\theta^H(0.5, \eta^M)}{(d\eta^M)^2} \quad (22)$$

Secant modulus for H and M metals is calculated from Eqs. (8) - (11).

When $\gamma_N > 1$ stress σ_z acts and strains e_θ , e_r , e_z are changed due to their bending components. In this case strains $e_\theta^b = e_\theta - 0.5\sigma_z/E'$, $e_r^b = e_r - 0.5\sigma_z/E'$, $e_z^b = e_z + \sigma_z/E'$ are obtained by using the superposition principle. Strains e_θ , e_r , e_z are determined from Eqs. (7) and (8) when $\sigma_z = 0$. Then from the expression of strain intensity it follows

$$e_i = \frac{\sqrt{2}}{3} \sqrt{(e_r - e_\theta)^2 + (e_\theta - e_z - 1.5\sigma_z/E')^2 + (e_z - e_r + 1.5\sigma_z/E')^2} \quad (23)$$

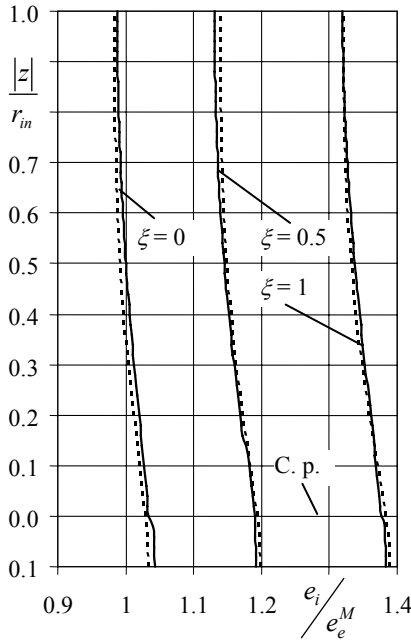

a

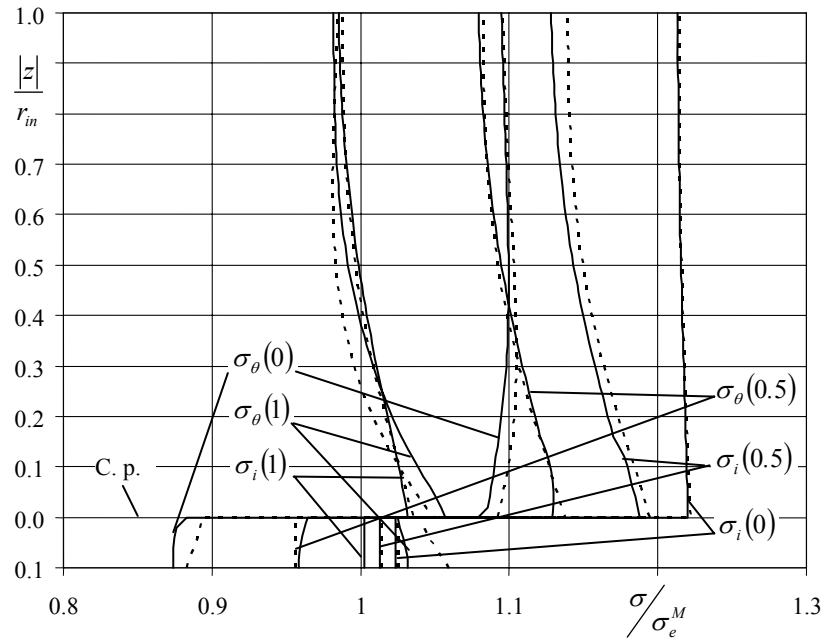

b

Stress intensity $\sigma_i(\xi, \eta)$ is determined from Eq. (10). The circumference stress is obtained from dependence $\sigma_\theta = f(\sigma_i)$:

$$\sigma_\theta(\xi, \eta) = \frac{1}{2} \left\{ \sigma_r(\xi) + \sigma_z(\xi, \eta) + \sqrt{4\sigma_i(\xi, \eta)^2 - 3\sigma_r(\xi)^2 - 3\sigma_z(\xi, \eta)^2 + 6\sigma_r(\xi)\sigma_z(\xi, \eta)} \right\} \quad (24)$$

Maximum value of pressure p_{max} when this solution is valued may be determined from Eq.(6) when $\xi_p^H = 0.5$ and $\sigma_e = \sigma_e^H$.

3. Stress strain distribution at elastic-plastic loading

Stress strain distribution in welded joint of grade 15X2MΦA steel with square cross-section shape manual weld welded with electrode YOHИ-13/45A is analyzed in this work. Mechanical properties of the base metal: $\sigma_e^H = 490$ MPa; $\sigma_{0.2}^H = 534$ MPa; $\sigma_{ut}^H = 722$ MPa; $e_u^H = 8.6\%$; $\psi^H = 73.8\%$; $m^H = 0.129$; $E^H = 2 \cdot 10^5$ MPa and mild weld metal: $\sigma_e^M = 425$ MPa; $\sigma_{0.2}^M = 439$ MPa; $\sigma_{ut}^M = 545$ MPa; $e_u^M = 12\%$; $\psi^M = 69.5\%$; $m^M = 0.075$; $E^H = 2 \cdot 10^5$ MPa [1].

Distribution of stresses and strains in separate zones of welded pipe was calculated analytically from Eqs. (2) - (24) and determined by FEM

Fig. 6 Distributions of stress strain state components when $s = 0.2$, $\xi_p^H = 0.3$: a – strain intensity; b – circumference stress and stress intensity; (---) – calculated analytically and (—) – determined by FEM; C. p. – contact plane

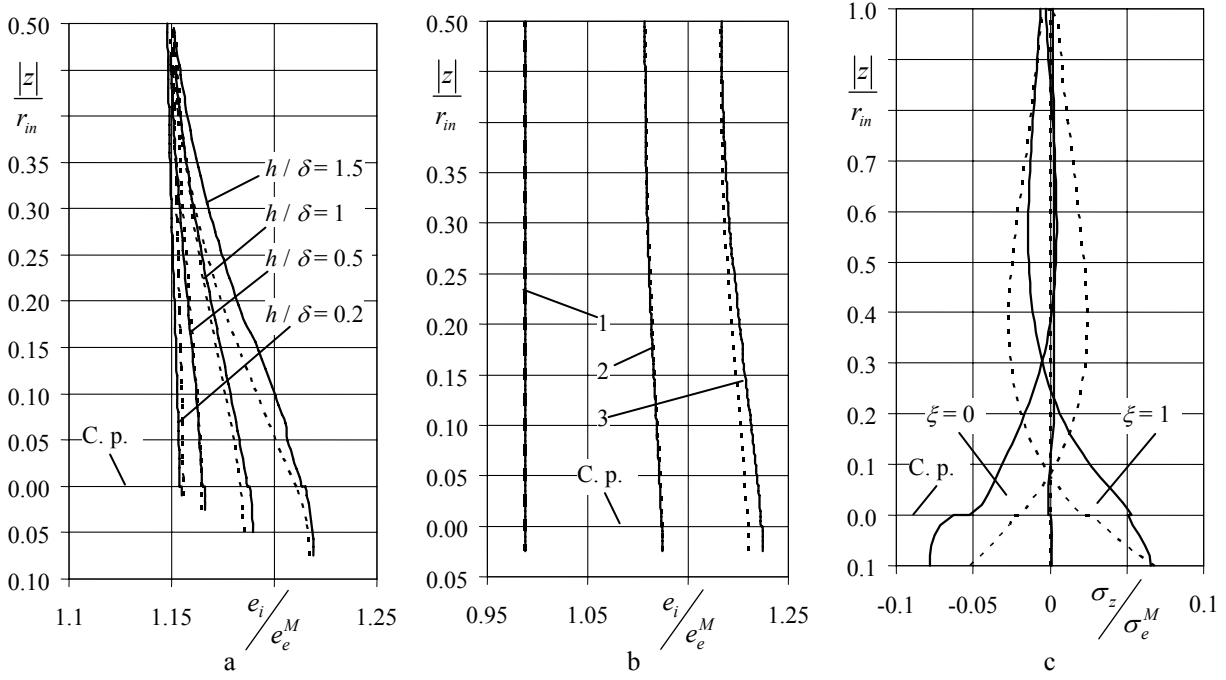

Fig. 7 Distributions of strains and stresses: a – strain intensity at longitudinal section $\xi=0.5$ from α^H , when $s=0.1$, $\xi_p^H=0.3$; b – strain intensity at longitudinal section $\xi=0.5$ from ξ_p , when $s=0.05$, $h/\delta=1$, where $1 - \xi_p^M < 0.5$, $2 - \xi_p^M > 1$ and $0 \leq \xi_p^H$, $3 - \xi_p^H = 0.3$; c – longitudinal stresses, when $s=0.2$, $\xi_p^H=0.3$; (---) – calculated analytically; (—) – determined by FEM; C. p. – contact plane

The most heavily loaded zones, as follows from Fig. 6, are on the inner surface of the pipe: in base metal – at the contact plane, in mild metal – at the centre of mild interlayer. Strain intensity in these zones increase with increasing pressure p and relative height of interlayer α^M .

Dependence welded pipe strain intensity on the relative height h/δ is shown in Fig. 7, a. From Fig. 7, a follows that with decreasing of α^M strain intensity at the centre of a mild weld also decreases.

Dependence of strains intensity in longitudinal section $\xi=0.5$ on elasto-plastically deformed zone ξ_p is shown in Fig. 7, b.

The largest values $|\sigma_z|$ are in the most loaded zones when $\xi=0$ and $\xi=1$. $|\sigma_z(0)|$ and $|\sigma_z(1)|$ increases with increasing α^H and decreasing s . $|\sigma_z|$ rapidly decreases with increasing the distance from contact plane and it disappears when this distance is equal α^H (Fig. 7, c).

When $\xi_p^H > 0$ maximum value of σ_θ^{H*} corresponds $\xi = \xi_p^{H*}$. In a mild metal $\sigma_\theta^{H*} = \sigma_\theta^{H*}(1)$, because its value decreases with increasing of elastic-plastic deformed zone at contact plane. The distribution of circumference and stresses intensity σ_θ^{H*} , σ_i^{H*} , σ_θ^{M*} and σ_i^{M*} is shown in Fig. 8. Values of circumference stress and stresses intensity increase with increasing pressure p and decreasing of relative thickness of the pipe wall s .

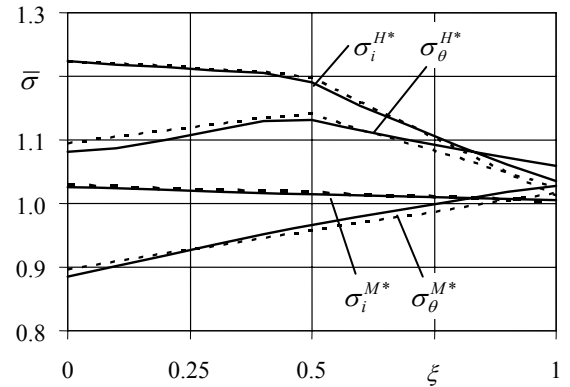

Fig. 8 Distributions of circumference and stresses intensity at contact plane, when $s=0.2$, $\xi_p^H=0.3$; (---) – calculated analytically; (—) – determined by FEM

5. Conclusions

1. The elastic-plastic strains in a welded pipeline with mild interlayer appear at the inner surface of mild weld. Their values and elastic-plastic deformed zone increase with increasing of pressure p .

2. Maximum values of stresses and strains are at the inner surface of the pipe: for base metal are at the contact plane and for mild metal – at the center of the interlayer. With decreasing relative thickness of the pipe wall s the circumference stress and strain at the inner surface of the pipe increases and at external surface of the pipe decreases.

3. Strain intensity e_i in the most heavily loaded zones decreases with decreasing a^M and approaches to its value in the cross-section removed from the contact plane at the distance a^H .

4. When mild metal at the contact plane in the zone $\xi_p^M > 0.5$ is deformed elastic-plastically due to the acting bending moment stresses σ_z^H and σ_z^M appear. Therefore strain intensity at inner surface of the pipe increases and at external – decreases. Stress rapidly decreases with increasing the distance from the contact plane. When this distance is equal a^H stress σ_z^H disappears.

References

1. **Bražėnas, A.** Strength and Low Cycle Fatigue Life of Mechanically Heterogeneous Butt Welded Joints. Monograph.-Kaunas: Technologija, 2002.-284p.
2. **Rudolph, J., Weiß, E.** Concept-conforming modelling and analysis of welded pressure vessel components in the context of structural, notch stress and local strain approaches to design against fatigue.-Weinheim, Germany: WILEY-VCH Verlag GmbH. Chemie Ingenieur Technik, 2002, Nr.1-2(74), p.33-40.
3. **Безухов Н.И.** Основы теории упругости, пластичности и ползучести.-Москва: Высшая школа, 1968, -512с.
4. **Kaminskas V., Bražėnas A.** Stress strain state determination of mechanically heterogeneous welded pipelines at elastic loading. -Mechanika.-Kaunas: Technologija, 2004, Nr.6(51), p.5-13.
5. Прочность при малоцикловом нагружении / Серенсен С.В., Шнейдерович Р.М., Гусенков А.П., и др. -Москва: Наука, 1975.-288р.

V. Kaminskas, A. Bražėnas

SUVIRINTO VAMZDYNO SU MINKŠTU
TARPSLUOKSNIU ĮTEMPIMŲ IR DEFORMACIJŲ
NUSTATYMAS ESANT PLOKŠČIAJAM ĮTEMPIMŲ
BŪVIUI IR TAMPRIAI PLASTINIAM
DEFORMAVIMUI

Reziumė

Darbe nagrinėjama suvirinto vamzdžio įtempimų ir deformacijų būvio komponentų priklausomybė nuo slėgio, santykinio sienelės storio ir medžiagų mechaninių savybių nevienalytiškumo. Nustatyta, kad, didėjant tampriai plastiškai deformuotai zonai kontakto plokštumoje, slėgiui p ir santykiui $\gamma_e = \sigma_e^H / \sigma_e^M$, mechaninio nevienalytiškumo parametras γ_N taip pat didėja.

Labiausiai apkrautos zonos yra vamzdžio vidiename paviršiuje: kietame metale – kontakto plokštumoje, minkštame – tarpsluoksnio centre. Analitiškai apskaičiuoti įtempimai ir deformacijos suvirinto vamzdžio atskirose zonos gerai sutampa su jų vertėmis, apskaičiuotomis BEM.

V. Kaminskas, A. Bražėnas

STRESSES AND STRAINS DETERMINATION OF
WELDED PIPELINES WITH THE MILD INTERLAYER
AT PLANE STRESS STATE UNDER ELASTIC-
PLASTIC LOADING

Summary

Dependence of stress strain state components on pressure, relative thickness of welded pipelines wall and mechanical heterogeneity of the welded joints materials is analyzed in this paper. It is determined that the mechanical heterogeneity parameter γ_N of welded joint increases with increasing elasto-plastically deformed zone at the contact plane, pressure p and ratio $\gamma_e = \sigma_e^H / \sigma_e^M$.

The most loaded zones are at the inner surface of the pipe: at the contact plane for hard metal and at the centre of a mild interlayer. The stresses and strains calculated analytically in the separate zones of welded pipe and determined by FEM showed a good agreement.

В. Каминскас, А. Браженас

ОПРЕДЕЛЕНИЕ НАПРЯЖЕНИЙ И ДЕФОРМАЦИЙ
СВАРНОГО ТРУБОПРОВОДА С МЯГКОЙ
ПРОСЛОЙКОЙ ПРИ УПРУГОПЛАСТИЧЕСКОМ
ДЕФОРМИРОВАНИИ И ПЛОСКОМ
НАПРЯЖЕННОМ СОСТОЯНИИ

Резюме

В настоящей работе приведена методика определения компонентов напряженно-деформированного состояния сварного трубопровода с мягкой прослойкой при упругопластическом деформировании и плоском напряженном состоянии. Представлены зависимости компонентов напряженно-деформированного состояния от давления, относительной толщины стенки трубы и неоднородности механических свойств сварного соединения. Определено, что параметр механической неоднородности сварного соединения γ_N увеличивается с увеличением размеров упруго-пластически деформированной зоны на контактной плоскости, давления p и соотношения $\gamma_e = \sigma_e^H / \sigma_e^M$.

Максимально нагруженной зоной является внутренняя поверхность трубы: в твердом металле – на контактной плоскости, в мягком – в центре прослойки. Напряжения и деформации, рассчитанные аналитически в отдельных зонах, хорошо соответствуют их значениям, определенными МКЭ.

Received December 27, 2004

DOI: 10.5755/j02.mech.13030