

Influence of surface hardening on low cycle tension compression and bending characteristics

M. Daunys*, A. Sabaliauskas**

*Kaunas University of Technology, Kęstučio 27, LT-44025 Kaunas, Lithuania, E-mail: mykolas.daunys@ktu.lt

**Kaunas University of Technology, Kęstučio 27, LT-44025 Kaunas, Lithuania, E-mail: arturas.s@tf.su.lt

1. Introduction

In real conditions, a lot of modern machinery and equipment elements work under cyclic elastic - plastic loading. The increasing loading velocities of this equipment, and the reduction of their dimensions made such working conditions extreme. At the same time, it is necessary to effect high strength and lifetime of these equipment. All these purposes cannot be achieved without the knowledge of materials low cycle strength and lifetime characteristics at different loading type. Very often the lifetime of an element depends not on the properties of the whole element but only on the properties of its surface. One of effective methods, increasing lifetime of the elements, is surface hardening, as in most cases the fracture starts on surface due to overloads, decreased resistance to plastic strains or due to the influence of operating medium. One of the methods for surface hardening is electromechanical treatment [1].

2. Methodology of electromechanical treatment

Electromechanical treatment (EMT) is the metal element surface treatment method based on local impact of force and heat in contact zone. In contact zone of the tool and treated surface electric current of high intensity and low voltage flows. As high intensity current flows on small contact area due to electric resistance in contact zone high heat energy is emitted and the contact zone is heated to the high temperature. The temperature is sufficient for austenitic transformation. The volume of heated surface layer is quite thin, so the heat is quickly directed to the depth towards element core. Thus the heated element surface layers quickly cool down and comparing to internal structural changes their hardens. In this way the "white layer" is composed.

For composing the hardened surface at KTU the EMT equipment applied to the work on turning lathe was used. Treatment tool – hard-fusion T15K6 plate was inserted into pressing device. Hard-fusion T15K6 is characterized by small coefficient of friction, good adhesive lifetime, and good electrical and thermal properties, given electrical density. The hard-fusion plate is polished and lapped.

Tool press force F is controlled using device indicator. Using EMT, simultaneously two processes occur: smoothing of surface roughness and surface layer hardening. During electromechanical hardening the following processing parameters were used: 1) hard-fusion T15K6 plate pressing force $F = 400$ N; 2) frequency of specimen rotation $n = 250$ rev/min; 3) processing speed $v = 7.85$ m/min; 4) feed of the instrument $s = 0.11$ mm/rev;

5) electrical current intensity $I = 220$ A; 6) passing number $i = 2$.

3. Investigation of monotonic and low cycle tension compression loading

Low frequency mechanical loading device with electronic-mechanical stress strain curves recording device was used for the investigation of monotonic and low cycle loading. 50 kN and 100 kN testing machines were used for monotonic and low cycle tension compression experiments [2].

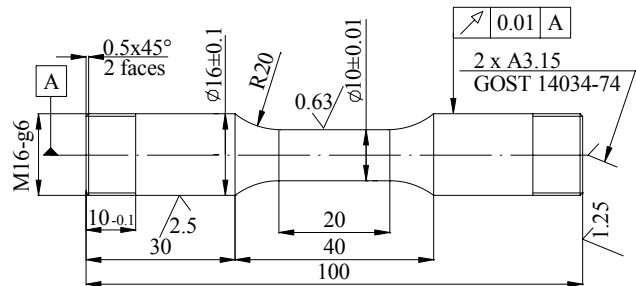

Fig. 1 Specimen for monotonic and low cycle tension compression

Circular cross-section specimens for monotonic tension and low cycle tension compression experiments were applied. These specimens were machined from bars of rolled grade 45 steel to the form and dimensions shown in Fig. 1.

The monotonic tension curves are presented in Fig. 2. The determined mechanical characteristics of grade 45 steel and grade 45 steel after EMT are presented in Table 1.

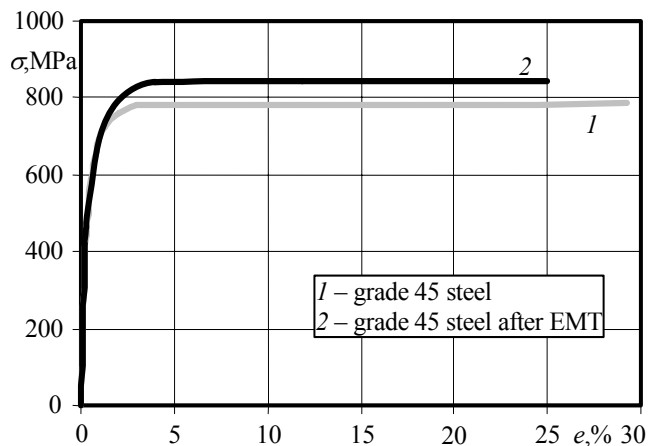

Fig. 2 Monotonic tension curves

Table 1
Mechanical characteristics of grade 45 steel and grade 45 steel after EMT

σ_{pr} , MPa	$\sigma_{0.2}$, MPa	σ_u , MPa	σ_f , MPa	e_{pl} , %	e_u , %	ψ , %
Steel 45						
375	544	786	882	0.22	29	65
Steel 45 after EMA						
424	580	842	769	0.24	25	19

As it can be seen in Fig. 2 and Table 1, after electromechanical processing differences in metal mechanical characteristics occur. The proportional limit σ_{pl} and ultimate strength σ_u for electromechanically hardened specimens are higher but the ultimate strain e_u and reduction of area at fracture is lower. The mechanical characteristics shown in Tab. 1 are mean values of monotonic tension of four tested specimens.

During low cycle tension compression stress limited loading was applied. Because under low cycle loading stress strain curves are changed depending on load level and the number of semicycles, so it is important to have these curves precisely recorded.

It is known, that the hysteresis loop width for cyclically anisotropic material is wider in even semicycle, than in uneven, i.e. $\bar{\delta}_2 > \bar{\delta}_1$. Therefore the expression of the width of hysteresis loop in semicycle k is written [2]

$$\bar{\delta}_k = A_{1,2} \left(\bar{e}_0 - \frac{\bar{s}_T}{2} \right) k^\alpha \quad (1)$$

where A_1 , A_2 and α are cyclic characteristics of material, \bar{e}_0 is strain of initial semicycle, \bar{s}_T is cyclic proportional limit, k is the number of semicycle.

For the determination of constants A_1 and A_2 according to low cycle stress limited tension compression experimental data we compose graphical dependence $\bar{\delta}_{1,2} = f(\bar{e}_0)$, i.e.

$$A_{1,2} = \frac{\bar{\delta}_{1,2}}{\left(\bar{e}_0 - \frac{\bar{s}_T}{2} \right)} \quad (2)$$

The width of hysteresis loop and the accumulation of plastic strain depend on the number of semicycles. After k th semicycle the accumulated plastic strain may be written as [3]

$$\bar{e}_{pk} = \bar{e}_0 - \bar{\sigma}_0 + \sum_{i=1}^k (-1)^i \bar{\delta}_i \quad (3)$$

where $\bar{\sigma}_0$ is stress of initial semicycle.

In Eqs. 1-3 stresses and strains are normalized to σ_{pl} and e_{pl} accordingly.

4. Investigation of low cycle pure bending

The experimental investigations of low cycle pure bending were performed using the above described equipment. Special set-up for specimen fixing was used at low

cycle pure bending fatigue test. Using this set-up in specimen operational area permanent bending moment M_b was created [3]. Fig. 3 shows a sketch of specimen fixing set-up. It consists of two sections: one (the nut 3 with the pair of ring 4 and supporting rollers 5) is fixed on machine's stationary grip 2; the other (the plate 7 with the supports 6 and supporting rollers 8) is screwed on machine's shifting grip 1.

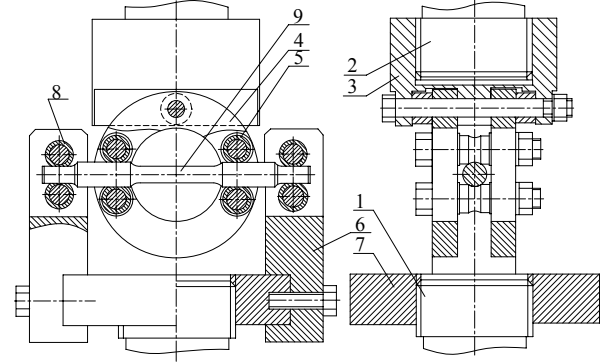

Fig. 3 Cyclic pure bending tests set - up

At pure bending the requirements for the specimen are the same as for the tension compression specimen [4]. The scheme of used hardened and nonhardened specimen for pure bending is shown in Fig. 4.

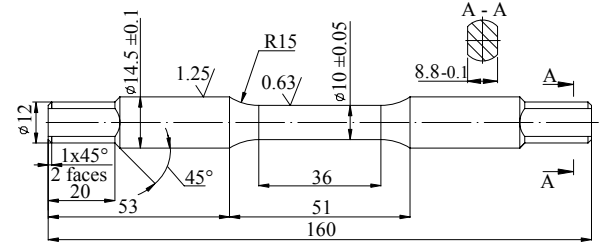

Fig. 4 Specimen for pure bending

During low cycle pure bending loading with limited stress was also performed, i.e. fixed bending moment M_b was applied. After the experiments the changes of hysteresis loops, constants, which evaluate anisotropy at different load stages, were also calculated.

5. Results of low cycle loading at tension compression and bending

The values of the hysteresis loop widths $\bar{\delta}_1$, $\bar{\delta}_2$ of tension compression and pure bending diagrams, which conform to various loading levels, are presented in Fig. 5.

In accordance to Eq. (2) the constants A_1 and A_2 for nonhardened and hardened grade 45 steel are presented in Table 2.

Table 2

Values of constants A_1 and A_2

Non hardened			Hardened		
A_1	A_2	ΔA	A_1	A_2	ΔA
Low cycle tension compression					
1.86	2.0	0.14	0.91	1.15	0.24
Low cycle pure bending					
1.26	1.3	0.04	1.07	1.18	0.11

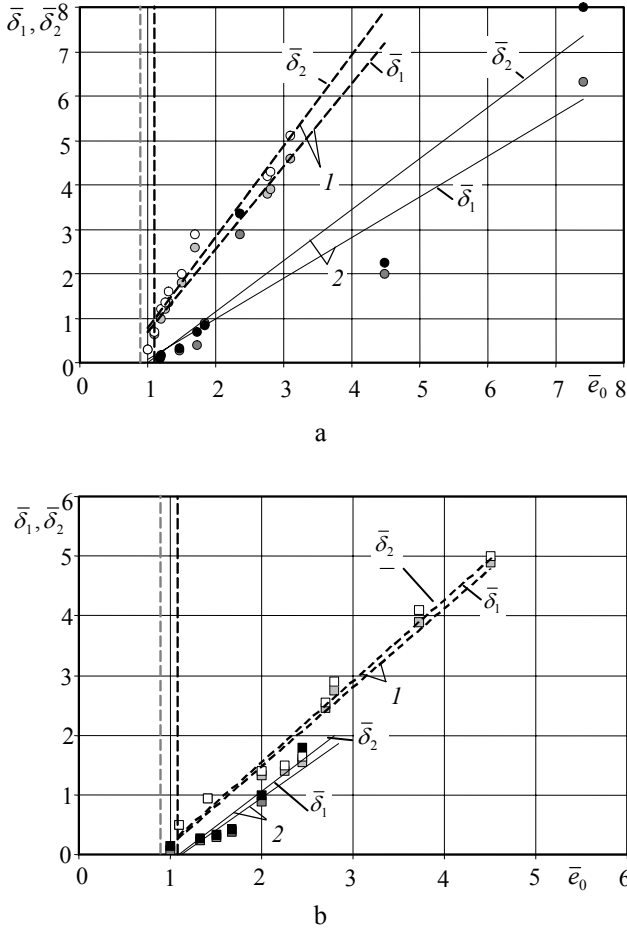

Fig. 5 Width of hysteresis loop after first and second loading semicycles for grade 45 steel (1) and grade 45 steel after EMT (2): a – for tension compression; b – for pure bending

The obtained results show that after electromechanical treatment, the constants A_1 and A_2 decrease. This is due to decreasing widths of the hysteresis loops. For low cycle stress limited symmetric loading the dependence of plastic strain hysteresis loops variation on semicycle number is presented in Fig. 6 and 7. This data were obtained by performing experiments at loading levels from $\bar{\sigma}_0 = 1.01$ to $\bar{\sigma}_0 = 1.95$ in case of tension compression and from $\bar{\sigma}_0 = 1.04$ to $\bar{\sigma}_0 = 1.8$ in case of pure bending. Where

$$\bar{\sigma}_0 = \frac{\sigma_0}{\sigma_{pl}} \quad (4)$$

here σ_0 is stress of initial semicycle for non-hardened steel; σ_{pl} is proportional limit for non-hardened steel.

The main parameter, which determines the dependence between the first and the k th semicycle hysteresis loop width, is exponent α , used in Eq. (1). By experimental investigation it is determined, that this value is variable. It depends on loading level. The values of this parameter in cases of tension compression and pure bending are presented in Fig. 8. Calculated average α_{mean} values are provided in Table 3.

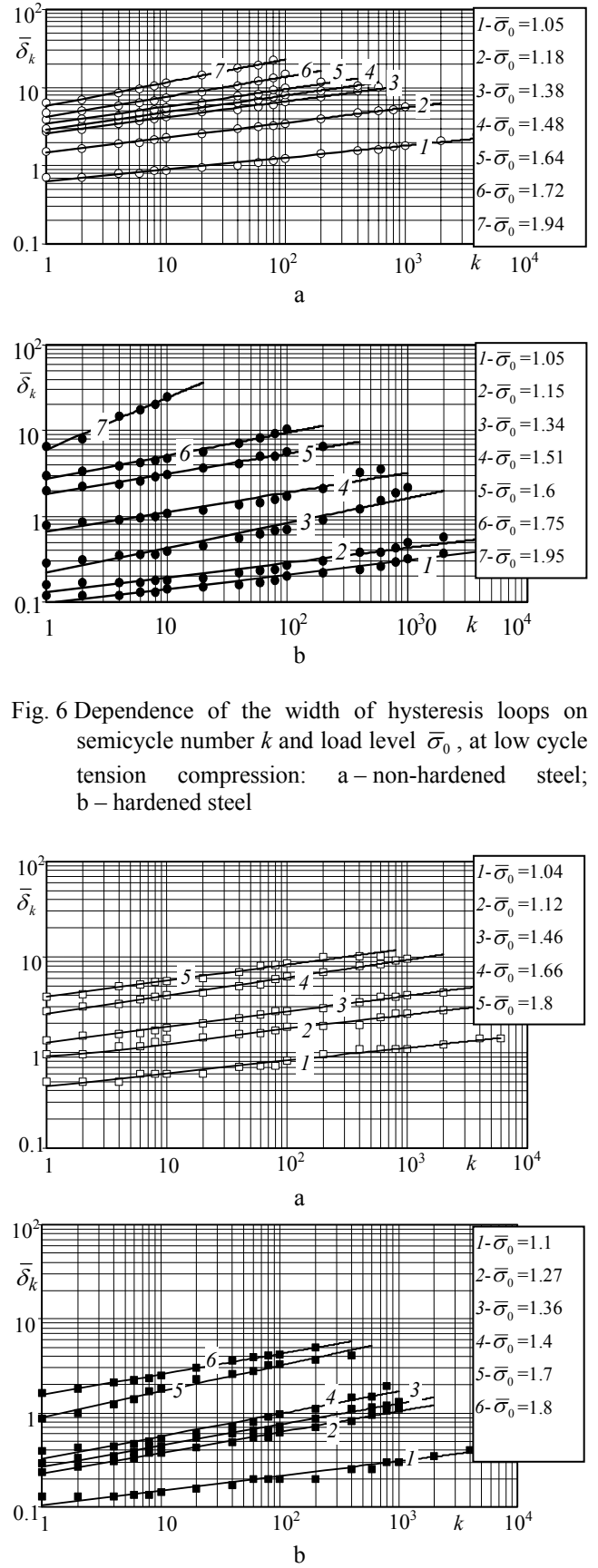

Fig. 6 Dependence of the width of hysteresis loops on semicycle number k and load level $\bar{\sigma}_0$, at low cycle tension compression: a – non-hardened steel; b – hardened steel

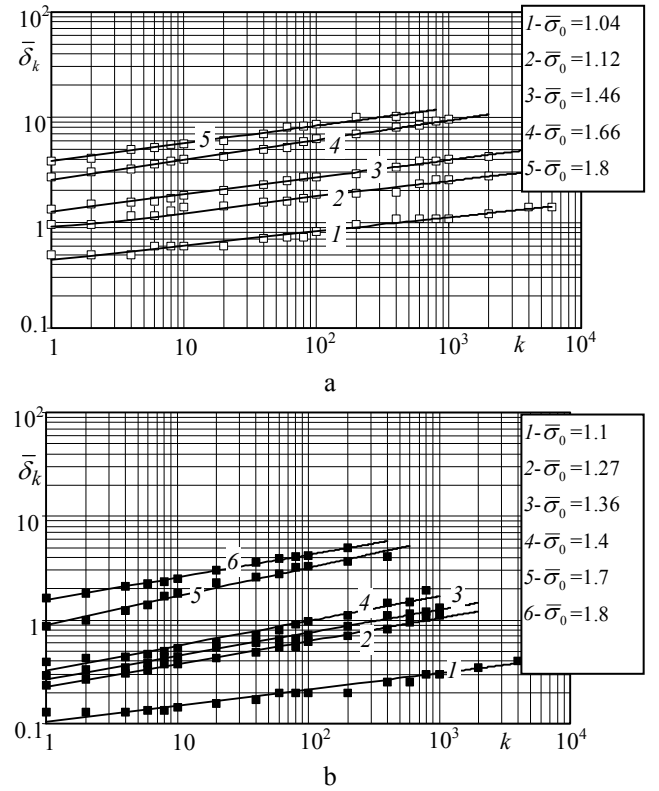

Fig. 7 Dependence of width of hysteresis loops on semicycle number k and load level $\bar{\sigma}_0$, at low cycle pure bending: a – non hardened steel; b – hardened steel

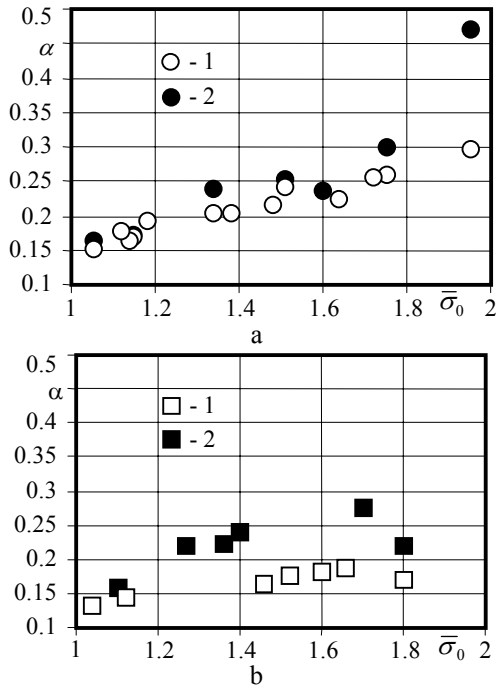

Fig. 8 Dependence of parameter α on loading level $\bar{\sigma}_0$ for non-hardened steel (1) and hardened steel (2): a) at low cycle tension compression; b) at low cycle pure bending

Table 3

Average values of parameter α_{mean}

	Grade 45 steel	Grade 45 steel after EMT
Tension compression	0.2	0.26
Pure bending	0.18	0.22

The parameters α , at low cycle pure bending are situated similarly as in case of tension compression, but their values in all loading levels of pure bending are smaller. This can be noticed in average values of α_{mean} .

As it was mentioned above, the width of hysteresis loop for anisotropic materials is larger in even semicycles than in uneven semicycles; therefore during the low cycle loading the material receives increasing of plastic strain in the direction of tension. The experimental tension compression and pure bending curves of accumulated plastic strain \bar{e}_{pk} are presented in Fig. 9 and Fig. 10.

The diagrams show that during tension compression the accumulation plastic strain in the direction of tension in hardened material is slower. And only in a very large stress range ($\bar{\sigma}_0 = 1.95$), \bar{e}_{pk} may reach the value of relative fracture strain \bar{e}_u .

The layer, hardened by EMT, prevents the development of plastic strains. This is extremely obvious when middle and high amplitude of loading are used. As \bar{e}_u of hardened steel is smaller, so with high amplitude cyclic loading it is reached rather quickly. Therefore the lifetime of hardened specimen at high stress levels decreases. Having small amplitude loading, the “white layer” blocks accumulate plastic strain, so the lifetime of specimen is increasing. This can be seen in Fig. 11 both in case of tension compression (curves 3, 4) and in case of pure bending (curves 1, 2).

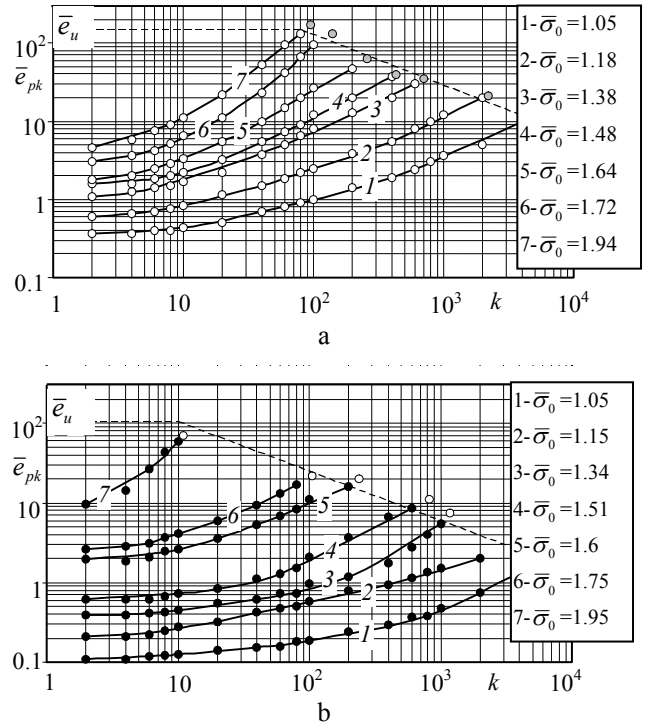

Fig. 9 Dependence of accumulated plastic strain \bar{e}_{pk} at tension compression on semicycle number k and load level $\bar{\sigma}_0$: a – grade 45 steel; b – grade 45 steel after EMT

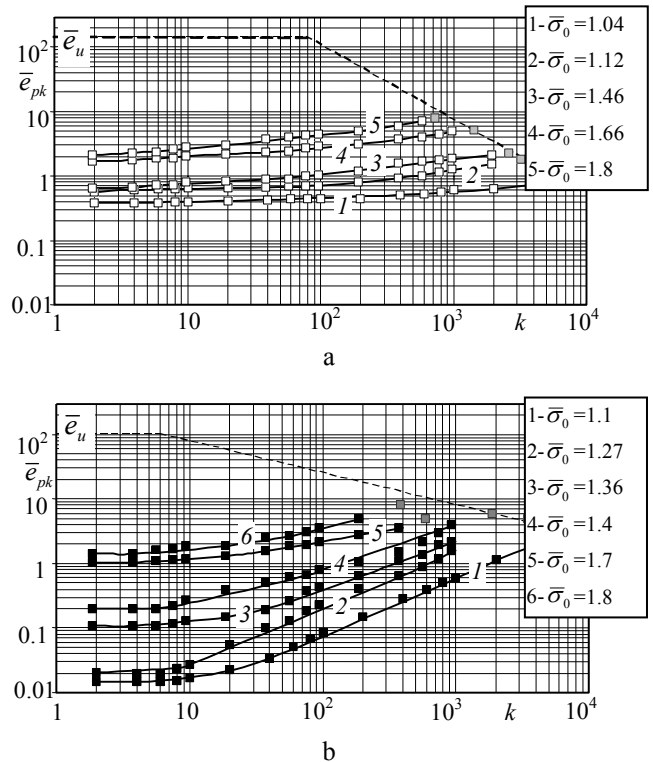

Fig. 10 Dependence of accumulated plastic strain \bar{e}_{pk} at pure bending on semicycle number k and load level $\bar{\sigma}_0$: a – grade 45 steel; b – grade 45 steel after EMT

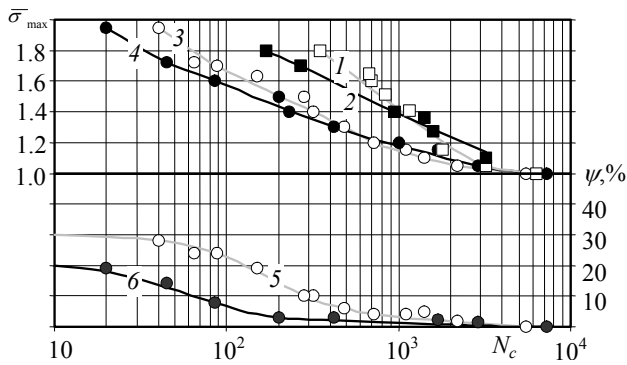

Fig. 11 Low cycle fatigue and reduction of area of fracture ψ curves for non-hardened (curves 1, 3, 5) and hardened (curves 2, 4, 6) specimens

6. Conclusions

1. The investigation of low cycle loading showed that non-hardened and hardened specimens of grade 45 steel using EMT are cyclically weakening and accumulating plastic strains. Therefore fatigue and quasi-static damage accumulation occurs.

2. During pure bending the width of hysteresis loop of plastic strain and the accumulation of plastic strain in the tension direction is smaller than these parameters at tension compression. This decrement is probably originated from the resistance of elastically strained inner layers of specimen to plastic strain during the pure bending.

3. In both tension compression and pure bending cases the hardened surface layer decreases the width of hysteresis loop and the accumulation of strain in the tension direction.

4. Under high loading level electromechanical hardening reduced the ultimate strain \bar{e}_u therefore has negative influence on element lifetime at high stress levels. But at the middle and low loading levels the lifetime is decreasing because of accumulation of \bar{e}_{pk} .

References

1. Barry J., Byrne G. TEM Study on the surface white layer in two turned hardened steels.-J. Materials Science and Engineering, 2002, v.325, No1-2, p.356-364.
2. Даунис М. А. Прочность и долговечность при малоцикловом нестационарном нагружении. -Вильнюс: Мокслас, 1989.-253с.
3. Daunys M., Rimovskis S. Analysis of low cycle loading characteristics at pure bending.-Mechanika. -Kaunas, Technologija, 2002, Nr.5(37), p. 5-9.

M. Daunys, A. Sabaliauskas

SUKIETINTO PAVIRŠIAUS ĮTAKA MAŽACIKLIO TEMPIMO GNIUŽDYMO IR LENKIMO CHARAKTERISTIKOMS

Reziumė

Darbe nagrinėtos bandinių su elektromechaniškai sukietintu paviršiumi statinės ir mažaciklio apkrovimo tempimo gniuždymo ir gryojo lenkimo charakteristikos.

Nustatyta, kad esant statiniam apkrovimui, padidėja sukietintų bandinių stiprumo charakteristikos (σ_{pl} , $\sigma_{0.2}$, σ_u) ir sumažėja deformavimo charakteristikos (e_u , ψ). Esant cikliniam minkštam tempimui gniuždymui, sumažėja sukietinto bandinio histerezės kilpos plotis ir vienpusės sukauptos deformacijos dydis, o ilgaamžiškumas, esant žemiems apkrovimo lygiams padidėja dėl sumažėjusio vienpusės deformacijos kaupimosi greičio. Ciklinio gryojo lenkimo metu ši tendencija išlieka, tačiau šiuo atveju ilgaamžiškumas, esant visiems apkrovimo lygiams, yra didesnis už ilgaamžiškumą tempimo gniuždymo metu.

M. Daunys, A. Sabaliauskas

INFLUENCE OF SURFACE HARDENING ON LOW CYCLE TENSION COMPRESSION AND BENDING CHARACTERISTICS

Summary

This paper analyses monotonic and low cycle tension compression and pure bending characteristics of specimens with electromechanically hardened surface. The performed experiments showed that under monotonic tension strength characteristics (σ_{pl} , $\sigma_{0.2}$, σ_u) are increasing and strain characteristics (e_u , ψ) are decreasing. During cyclic stress limited tension compression at low loading levels both the width of plastic strain hysteresis loop and accumulated plastic strain are decreasing, therefore the lifetime is increasing. Under pure bending this tendencies persist, but in this case the lifetime at all loading levels is larger than the lifetime at tension compression.

М. Даунис, А. Сабальяускас

ВЛИЯНИЕ УПРОЧНЕННОЙ ПОВЕРХНОСТИ НА ХАРАКТЕРИСТИКИ МАЛОЦИКЛОВОЙ УСТАЛОСТИ ПРИ РАСТЯЖЕНИИ СЖАТИИ И ИЗГИБЕ

Резюме

В настоящей работе при статическом и малоцикловом растяжении сжатии и изгибе исследовано прочность и долговечность образцов из стали 45 с упрочненной поверхностью. Определено, что при статической нагрузке увеличиваются прочностные характеристики (σ_{pl} , $\sigma_{0.2}$, σ_u) и уменьшаются деформационные характеристики (e_u , ψ). В образцах с упрочненной поверхностью, при мягком малоцикловом растяжении сжатии уменьшается ширина петли упруго-пластического гистерезиса и односторонняя накопленная деформация, из-за чего долговечность при низком уровне нагрузки возрастает. Эта тенденция наблюдается и при чистом циклическом изгибе. Долговечность при всех уровнях чистого изгиба превышает долговечность при растяжении сжатии.

Received November 25, 2004

DOI: 10.5755/j02.mech.13031