

Methods for decrease of dynamic loading of processing system pumping units

S. Kravets*, V. Subbotovsky**, Y. Ilyina**

*Volgodonsk Institute of South Russian State Technical University, 13, blv. Velikoy Pobedy, 347371 Volgodonsk, Russia, E-mail: kravets@vnet.ru

**Volgodonsk Center of All-Russian Scientific and Research and Design Institute of Nuclear Power Engineering, 13, blv. Velikoy Pobedy, 347371 Volgodonsk, Russia

1. Introduction

Excessive dynamic loads at operation of pumping units are the most dangerous for their reliable operation. Vibration, appearing while the pump operating, causes the excessive loading, first of all, of the bearing units not intended for these loads that is finally a reason of functionality failure of the unit as a whole. At present, there are many means and methods for decrease of dynamic loading on the rotating units. Let's review two of them based on

definite example of the pumping units for sea water supply.

2. Method description

The reviewed pumping unit looks like a vertical console structure, which is fixed on the foundation by means of bolts. The unit sketch is illustrated in Fig. 1. The direction of working medium motion is shown with by arrows.

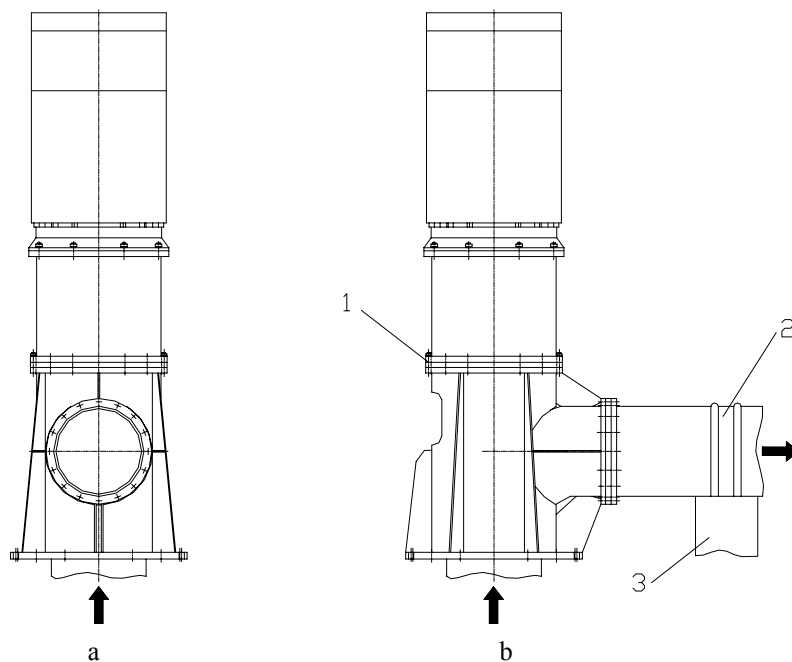

Fig. 1 Pump sketch

After erection works it was noticed that the pumping unit is under the excessive vibration loads at operational conditions. In order to study their reason, the vibration parameters were registered at operational conditions. Measurement was performed using vibration single-channel analyzer "Topaz". Based on the measurement results at operating pumping units it was found out that the vibration level is higher than the set one. The measured vibration spectrum is illustrated in Fig. 2.

As it can be seen from the spectrum illustrated in Fig. 2, the maximum amplitude of vibration speed corresponds the frequency of 16.25 Hz. It is known that in small period of time the whole structure will vibrate with the frequency of external disturbing force which changes in harmonic law. So, frequency of disturbing force in our case

is $\omega = 16.25$ Hz. To decrease the vibration it is necessary to define the reasons causing it. To do it, the natural vibration frequencies of the pumping unit were experimentally defined on the non-operating unit by analyzing damped free vibration. For that, the impulse method of free vibration excitation of the equipment using single power impulses was used.

As it is obvious from the spectrum illustrated in Fig. 3, the natural frequency of the unit free vibrations is $p = 16.75$ Hz.

The performed comparative analysis of vibration spectrum of the operating unit (see Fig. 2) and the spectrum of vibration natural frequencies (see Fig. 3) has proved that the frequency values are very similar

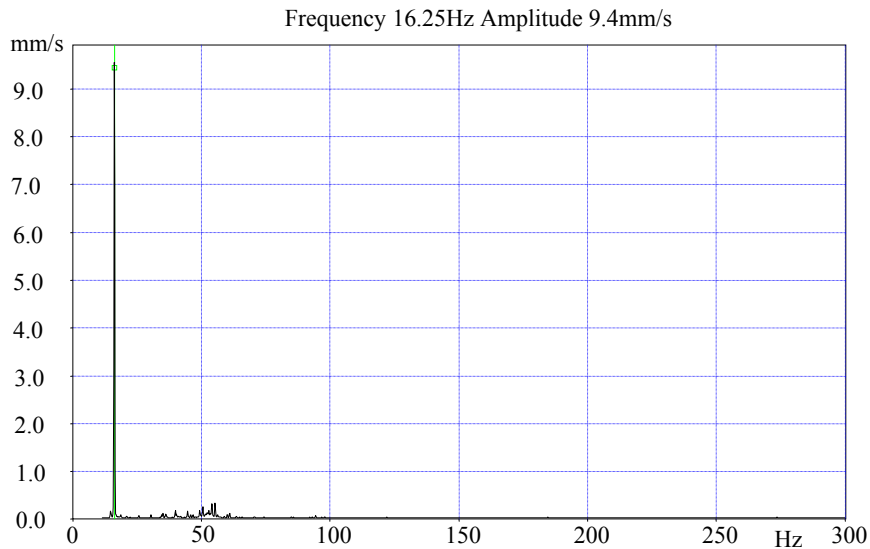

Fig. 2 Vibration spectra of operating pumping unit

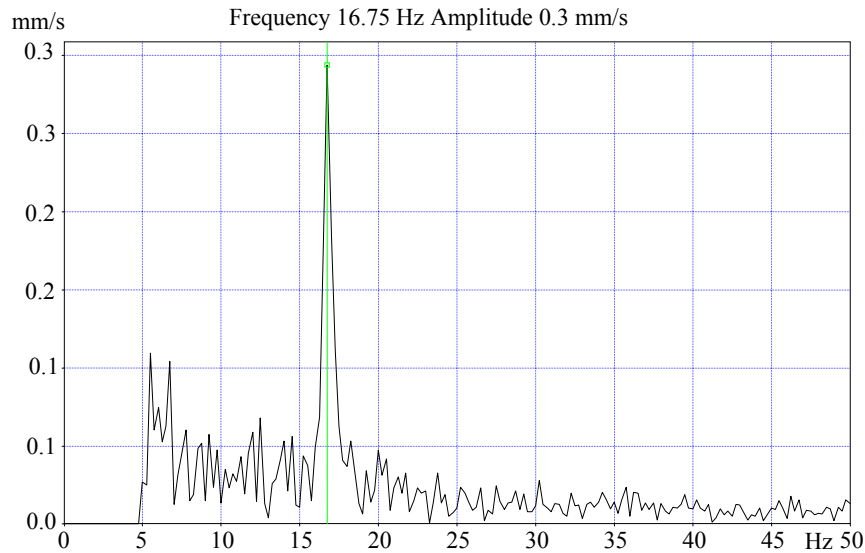

Fig. 3 Initial spectrum of natural frequencies of the unit vibration

($\omega=16.25$ Hz and $p=16.75$ Hz). So, it is logical to suppose that the reason of the excessive vibration is resonance. As it is known, the dynamicity factor μ is calculated by the formula

$$\mu = \frac{1}{\sqrt{\left(1 - \frac{\omega^2}{p^2}\right)^2 + \frac{4\omega^2\delta^2}{p^4 T^2}}}$$

where ω is the frequency of disturbing force; p is the frequency of free vibrations; δ is logarithmic decrement of vibrations; T is vibration period.

In order to decrease the dynamicity factor and consequently to decrease the dynamic loading and vibration amplitude it is necessary to separate the frequencies of disturbing force and natural vibrations. It is not recommended in the reference literature [1] to use the zone $p = 0.7 - 1.3\omega$ for operational modes. But in practice, it is impossible to follow this requirement fully for the assembled structures. That's why, it is possible to get the values

at least equal to $p = 0.9 - 1.1\omega$.

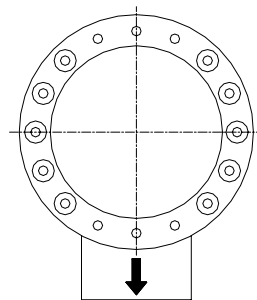

Fig. 4 Arrangement diagram of gaskets (top view)

It is difficult in practice to change the disturbing force frequency ω because of structural peculiarities of the pumping unit referred to the rotation frequency of the electric drive. So, the only one way to increase the range between the values of disturbing force frequency ω and natural vibration frequency p is to change of the natural frequency of the pumping unit vibration. In this case, it is decided to decrease natural frequencies values of the struc-

ture.

To decrease the unit rigidity, 10 tinned gaskets of 0.6 mm thickness each are used. They are installed in the flanged joint 1 (Fig. 1, b) between the lamp and the pump body in accordance with the diagram illustrated in Fig. 4

(arrow indicates the working medium motion direction).

As it is seen from the spectrum of natural frequencies of the unit vibration illustrated in Fig. 5, after installation of the gaskets the free vibration frequency decreased and was equal to $p=15.13$ Hz.

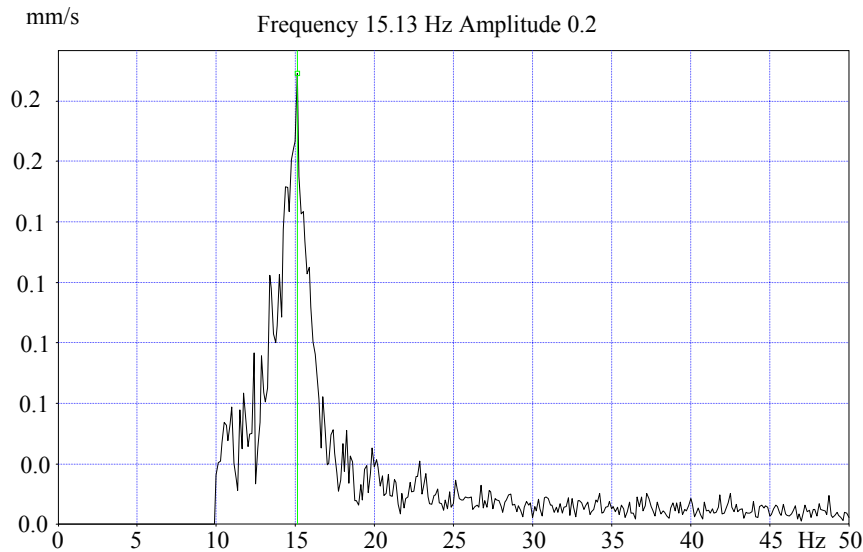

Fig.5 Spectrum of natural frequencies of the unit vibration after installation of the gaskets

Re-registration of vibration parameters under operational conditions (Fig. 6) done after decrease of the unit free vibration frequency has proved that the maximum

value of the amplitude of vibration speed of operating unit has been decreased for more than 4 times (9.4 and 2 mm/s).

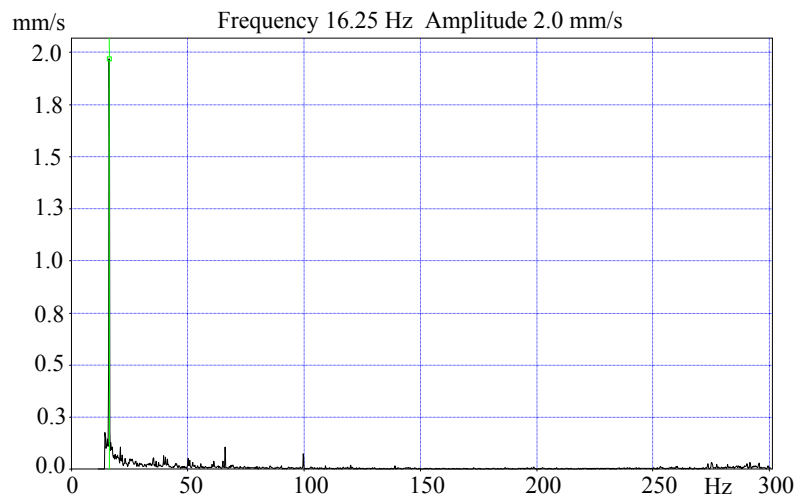

Fig. 6 Vibration spectrum of operating pumping unit after installation of the gaskets

Let us review another method for decreasing of the dynamic loading of pumping units. As an example, let us choose the pumping unit similar to the previous one and having the same arrangement of the connected pipeline.

Like the previous case, the vibration level of the operating pump was higher than necessary. Having done the same operations described for the first case, it is defined that the disturbing force frequency for the pumping unit is $\omega=16.45$ Hz (Fig. 7) and natural frequency is $p=16.5$ Hz (Fig. 8).

In order to move from resonance zone it was decided to take another way, namely, to increase natural vibration frequencies of the structure.

It is possible to increase the natural frequency of

the pumping unit by increasing the structure rigidity having eliminated the possibility of small movement in horizontal and vertical directions perpendicular to the pipeline axis. For that, the gaps between the pipeline and support (positions 2 and 3 in Fig. 1, b) were removed. Sliding support was arranged at the distance of 1.5 meters from the flanged joint of the pump. The gap was removed by putting the gaskets to reach even adjacency of the pump to the buckle and support.

As it is seen from the spectrum of natural frequencies of the unit shown in Fig. 9, the removal of gaps between the pipeline and support has caused the increase of free vibration frequency up to the value of $p=17.75$ Hz.

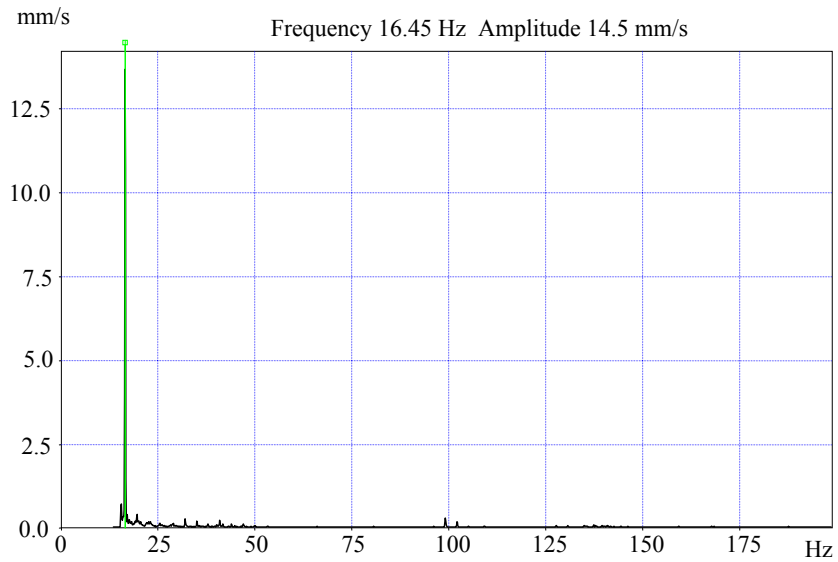

Fig. 7 Vibration spectrum of operating pumping unit

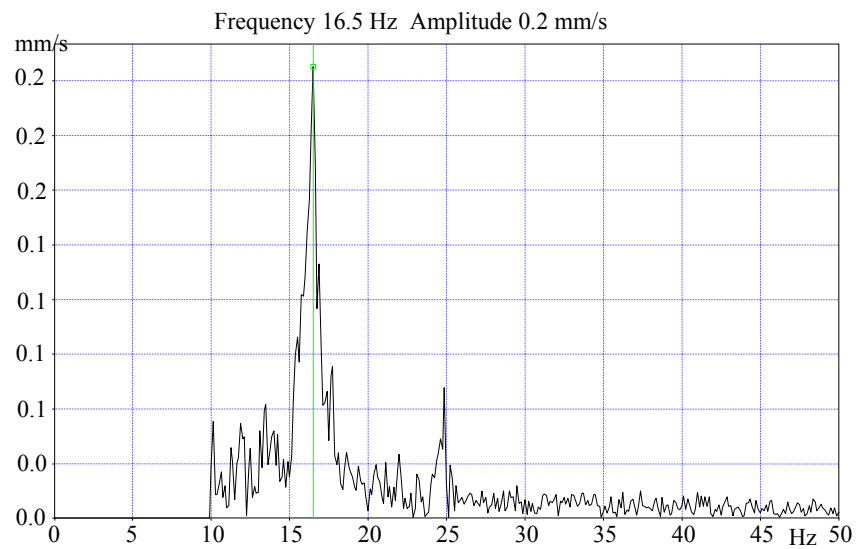

Fig. 8 Initial spectrum of natural frequencies of the unit vibration

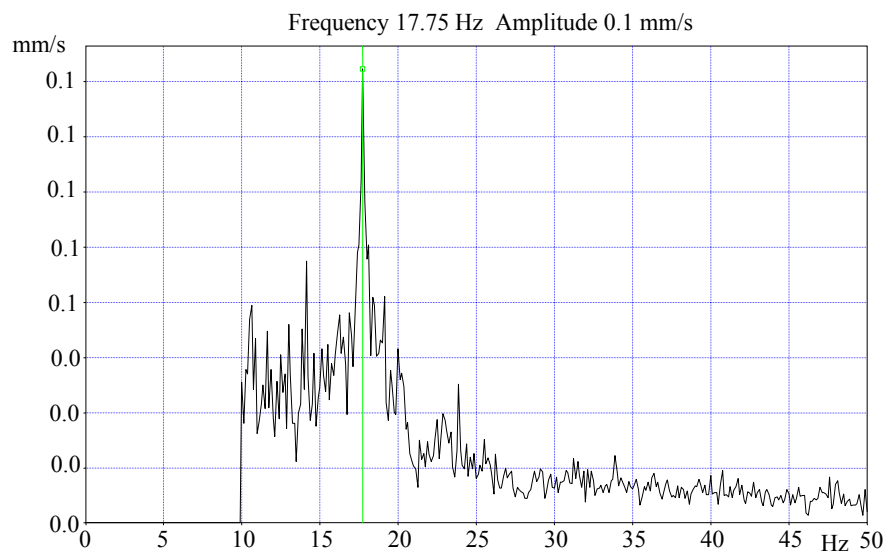

Fig. 9 Spectrum of natural frequencies of the unit vibration after removal of the gap

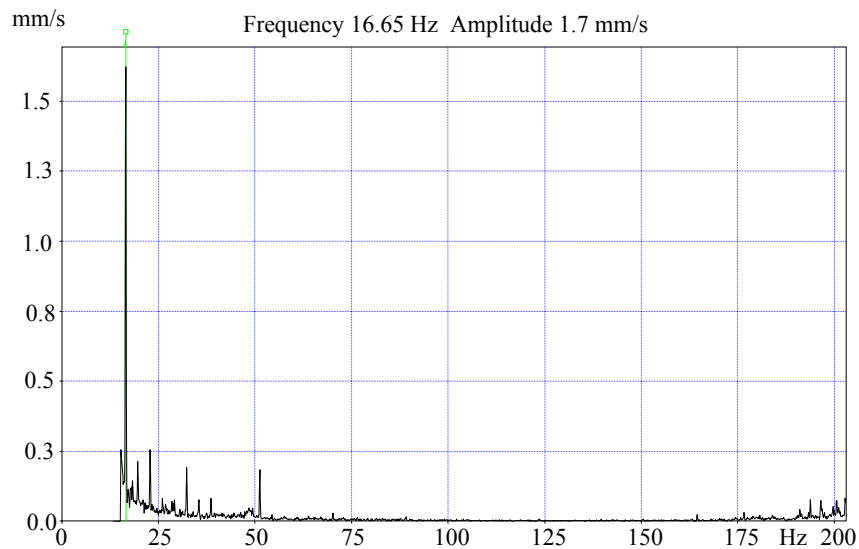

Fig. 10 Vibration spectrum of operating pumping unit after installation of the gaskets

Re-registration of the vibration parameters under operational conditions done after increase of the unit free vibration frequency has proved that maximum value of the amplitude of vibration speed of the operating unit has decreased for more than 8 times (13.5 and 1.64 mm/s) (Fig. 10).

3. Conclusion

So, comparing the results of the applied methods it is possible to point out the following. If after erection works of the pumping units, the frequencies of the disturbing force ω and natural vibration p are very close to each other, then the most preferable is the method of dynamic loading decrease, which is described. This method is based on the rigidity increase of these units. The first method of the dynamic loading decrease of the processing system pumping units is less preferable because when starting-up and stopping, the unit comes through the area of excessive vibration impacts. Moreover, this method is complicated and not convenient for executors (it is required to disassemble and assemble the structure).

References

1. Биргер И., Шорр Б., Иоселевич Г. Расчет на прочность деталей машин: Справочник.-Москва: Машиностроение, 1979.-702с.

S. Kravets, V. Subbotovsky, Y. Ilyina

TECHNOLOGINIŲ SISTEMŲ SIURBLIŲ DINAMINIŲ APKROVŲ SUMAŽINIMO METODAI

Straipsnyje aptarti siurblių vibracinių apkrovų sumažinimo būdai. Detaliai išnagrinėti praktiniai veiksmai, kaip galima sumažinti į technologinę sistemą įjungtų siurblių vibracines apkrovas.

S. Kravets, V. Subbotovsky, Y. Ilyina

METHODS FOR DECREASE OF DYNAMIC LOADING OF PROCESSING SYSTEM PUMPING UNITS

S u m m a r y

Methods for vibration loads decrease of pumping units are reviewed in this paper. Based on the definite pumps included in the processing system, practical actions for the decrease of their vibration loading were reviewed in details.

С. Кравец, В. Субботовский, Ю. Ильина

МЕТОДЫ СНИЖЕНИЯ ДИНАМИЧЕСКОЙ НАГРУЖЕННОСТИ НАСОСНЫХ АГРЕГАТОВ ТЕХНОЛОГИЧЕСКИХ СИСТЕМ

Р е з ю м е

В статье рассмотрены методы снижения вибрационных нагрузок насосных агрегатов. На примере конкретных насосов, включенных в технологическую систему, детально рассмотрены практические действия по уменьшению их вибронгруженности.

Received December 09, 2004

DOI: 10.5755/j02.mech.13035