

Effect of fluor-oligomer on tribological properties of friction couples under varying loads

J. Padgurskas*, Š. Skirka**

*Lithuanian University of Agriculture, Studentų 15, 53362 Akademija, Kauno reg., Lithuania,

E-mail: juozas.padgurskas@lzuu.lt

**Lithuanian University of Agriculture, Studentų 15, 53362 Akademija, Kauno reg., Lithuania,

E-mail: sarunas@metglasma.lt

1. Introduction

The effect of fluorine polymers on friction surfaces is an accepted knowledge. The polymers like PTFE, PEPE, etc. possess a low coefficient of friction [1]. Their application, however, is aggravated by complicated coating of surfaces and their treatment. For this reason, fluor-oligomer solutions are finding an increasing interest by offering comparatively easy ways of coating various friction surfaces. The prior experiments on the friction surfaces modified with "Foleox" type fluor-oligomer have proved that the latter used for coating of steel specimens reduces microhardness up to 17% in the depth up to 0.04 mm [2]. Tribological rolling tests in terms of the scheme: roller-roller friction machine SMC-2 have made it possible to determine that after 1.5 mill. cycles the fluor-oligomer coated surfaces used to wear out on the average 5 times less if compared to the uncoated ones [3].

In many modern machines the friction surfaces form a linear contact, as in gears, segmental or hydraulic pumps, where cyclic loads predominate. During their operation the loads prevailing in contact change, herewith changing the parameters of the entire system, while the units work under impacts.

Research objective is to analyze the effect of modifying the friction couples with fluor-oligomer under varying load conditions.

2. Wear measuring method

The experiments have been made in Harburg TU on the stand MPH-3 set for investigating tribological properties of hydraulic liquids (Fig. 1).



Fig. 1 Test stand MPH-3

A friction couple was formed of cylinder 1 (Fig. 2), made of steel 1.3505 (DIN EN 10 027-2) mounted on an eccentric shaft whose eccentricity was 2.5 mm, and a rod 2 made of steel 1.3343 (DIN EN 10 027-2). The rod was pressed on to the cylinder by pressure subjecting the rod holder. The length of a linear contact was 25 mm. Cyclic load variation resulted from the shaft eccentricity.

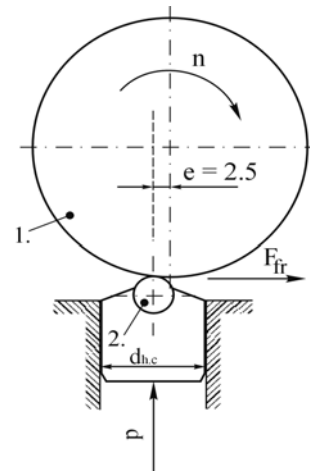

Fig. 2 Schematic diagram of a friction couple of test stand MPH-3, 1 – specimen-cylinder; 2 – specimen-rod

The parameters of a friction couple "cylinder-rod" were determined on the basis of the scheme given in Fig. 3.

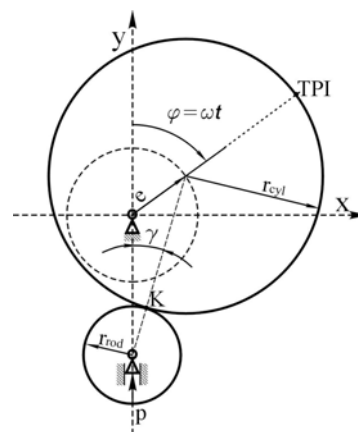

Fig. 3 Scheme of a friction couple "cylinder-rod": TPI - top point of immobility; K - projection of the specimens contact line to the front plane; φ - turn angle of the cylinder; γ - angle of the contact line projection K with respect to axis y; e - radius of eccentricity; r_{cyl} - radius of the cylinder; r_{rod} - radius of the rod

The variation of angle γ depending on turn angle φ of the cylinder is expressed by the following equation

$$\gamma(\varphi) = \arcsin \frac{e \sin(180 - \varphi)}{r_{rod} + r_{cyl}} \quad (1)$$

Angle γ acquires the maximum absolute numerical value when turn angle $\varphi = 90^\circ$ and $\varphi = 270^\circ$. In our case, i.e. when $e = 0.0025\text{m}$; $r_{cyl} = 0.045\text{m}$; $r_{rod} = 0.005\text{m}$ when $\varphi = 90^\circ$, then $\gamma_{max} = 2.866$, and when $\varphi = 270^\circ$, then $\gamma_{max} = -2.866$. The length of an arc forming the contact of the cylinder and the rod is calculated according to the formula

$$l_{c,r} = \frac{\pi r_{rod} \gamma_{max}}{90^\circ} \quad (2)$$

According to our data $l_{c,r} = 5.002 \cdot 10^{-4}\text{ m}$. It says that in the primary stage of the friction couple operation the rod will contact the line of cylinder which, due to the cylinder rotation, will fluctuate on the rod in the sector whose arc length $l_{c,r} = 5.002 \cdot 10^{-4}\text{ m}$. Referring to the calculations of contact geometry we can state that the wear of the rod is to be estimated according to the volume of worn material and n of according to the width of the worn band.

3. Experimental procedure

Prior to an experiment both friction surfaces were modified with 1% fluor-oligomer AK solution. When testing, the specimens were fully immersed into hydraulic oil HLP (DIN 51524 (2T)) enriched with EP-, AW- additives, their viscosity class being 46 according to ISO VG, and viscosity index – 97.

At the test outset the oil was heated up to 60°C by electric heaters. At start-up the pressure p in hydraulic cylinder was 3 MPa. The start-up is determined to be easier when the pressure is 3 MPa and not close to zero. When testing, the start-up pressure p was close to zero [4]. Revolution frequency of the eccentric shaft was gradually increased up to 650 min^{-1} . Pressure p was proportional to contact stresses σ_0 according to Hertz. Every 30 minutes the pressure in the system was increased 1 MPa by pressure controller until it reached 6 MPa.

The friction couple was tested for 40 hours. Then the moment of resistance of the shaft was measured. The measurement shaft was calculated for a critical 100Nm moment. Having reached it, the shaft was disconnected by a slipping clutch.

Prior and post the experiment, profiles of rod were measured by a profilegram, and from their difference the wear was calculated (Fig. 4).

Depending on the wear-out uniformity, 5 - 7 profilegrams were transversely made for each rod. From the profilegrams made before and after the experiment the volume of worn material was calculated

$$V = A_1 l_1 + \left(\frac{A_1 + A_2}{2} \right) l_{1-2} + \dots + \left(\frac{A_{n-1} + A_n}{2} \right) l_{(n-1)-n} + A_n l_n \quad (3)$$

where $A_1, A_2, \dots, A_{n-1}, A_n$ are calculated worn cross-section areas, mm^2 , respectively; l_1, l_n are distances, where l_1 is distance from one rod rear to the first cross-section meas-

ured by a profilegram and l_n is distance from the last cross-section to the other rod rear, mm; $l_{1-2}, \dots, l_{(n-1)-n}$ - distances between two adjacent cross-sections, mm.

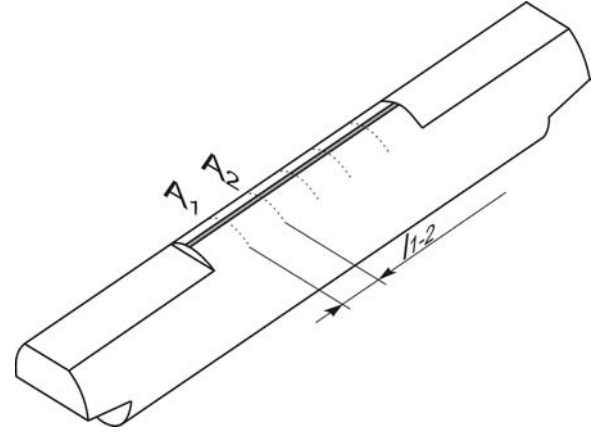

Fig. 4 Calculation scheme of the amount of worn material

Friction surfaces were investigated by means of optical microscopy. The worn surfaces were analyzed by an optic microscope and recorded by a digital photo camera “Leica” mounted on it. The main objective of that analysis was to clear out the surface mechanism.

4. Results and discussion

The “start” i.e. the beginning of an experiment was determined to pass analogically in both specimens: the one strengthened with fluor-oligomer and the reference one (Fig. 5). The maximum value of resistance moment did not exceed 35 Nm at the stand launching. When analyzing the friction variation (coefficient of friction μ) during running-in (Fig. 6) we have estimated that in modified friction couples the friction conditions have not changed with an increase in load, i.e. the coefficient of friction remained approximately constant. In the reference friction pairs the coefficient of friction has increased with an increase in load and it stabilized in some time (10-15 min). The running-in data enable us to state that the modification with fluor-oligomer has an effect on friction surfaces work-in thus influencing the results of long-term experiments. During the latter the moment of friction in both surfaces with fluor-oligomer and without them is virtually the same. It is evident that during long-term experiments the fluor-oligomer did not have an essential effect on the coefficient of friction μ . Different running-in processes of modified and non-modified friction couples may be assumed to have affected their wear.

When estimating the wear-out, the profiles of rods have been measured. When estimating wear-out, the rods with modified surfaces were found to be worn considerably less (Fig. 7-9), and their wear-out is spread all over their length. Fig. 10 illustrates the average variation of worn cross-section areas of the reference and fluor-oligomer AK modified rods. The graphs indicate that the wear-out of the modified rods is spread more evenly compared to the reference bars. If the wear-out in modified rods is almost even all over the rod length, the ends of reference rods are worn 2 - 3 times greater than their center. Comparison of both curves indicates that the center of a reference rod, where the wear-out is the least, is worn twice as much as that modified with fluor-oligomer AK.

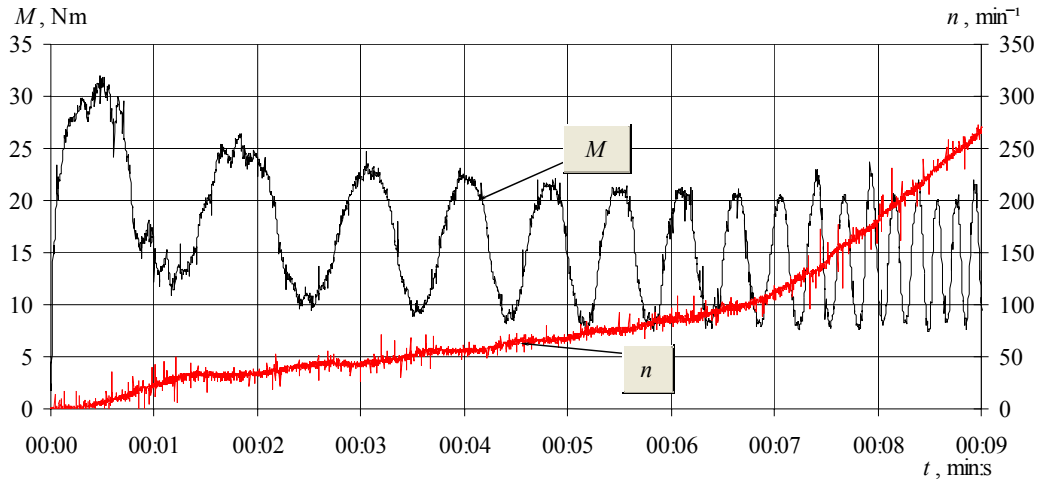

a

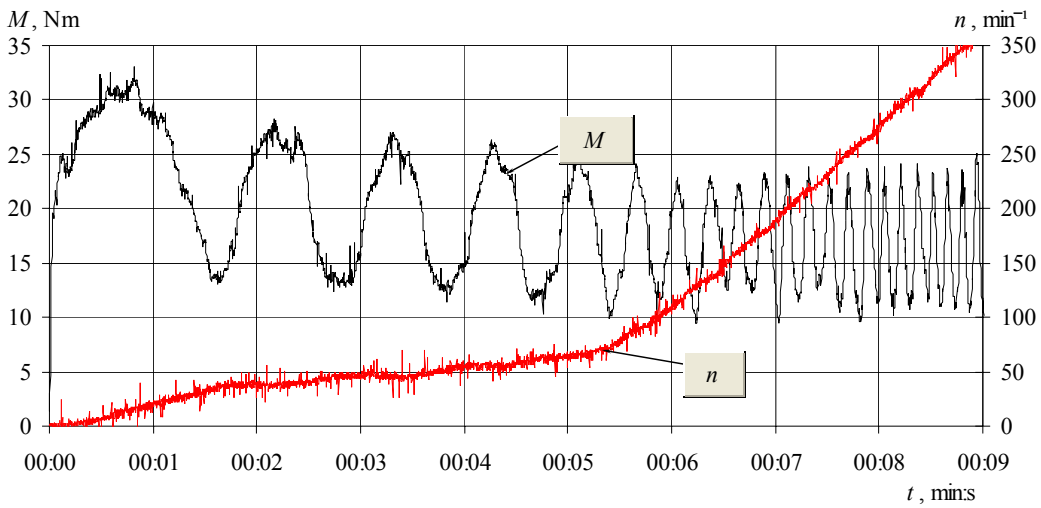

b

Fig. 5 Test start-up when testing a friction couple: a – modified with AK; b – reference

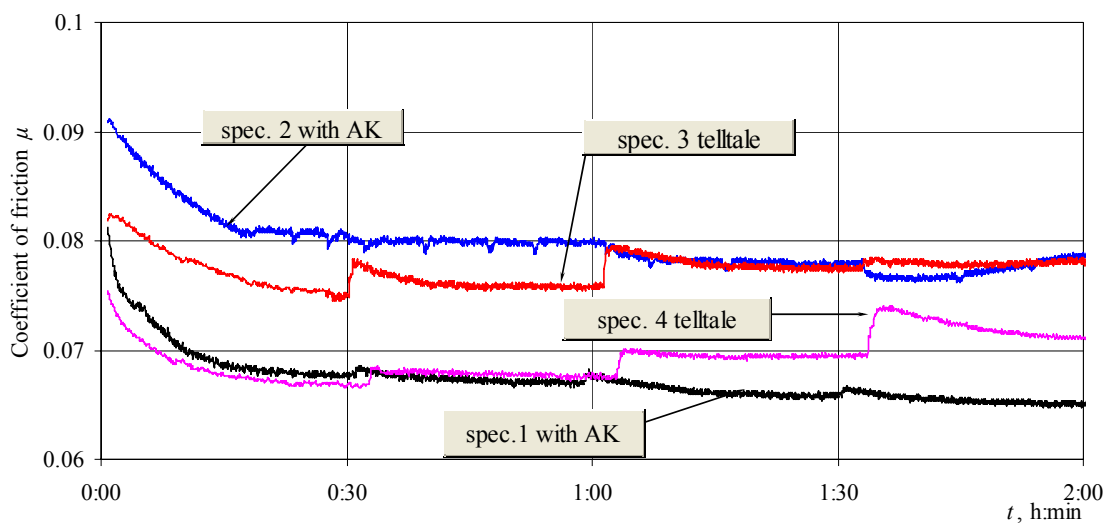

Fig. 6 Variation of friction coefficient μ during running-in

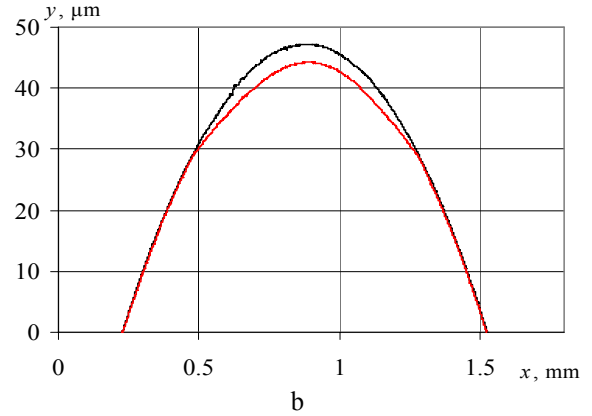
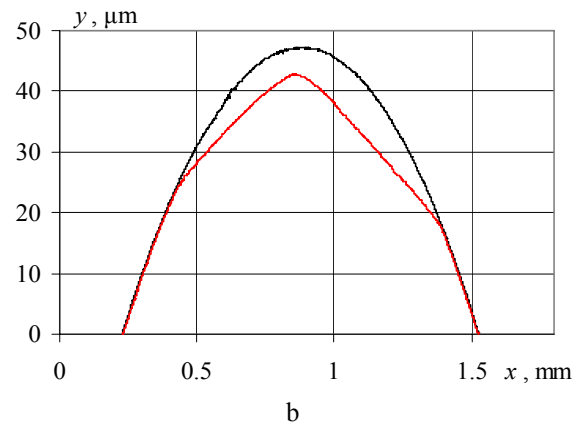
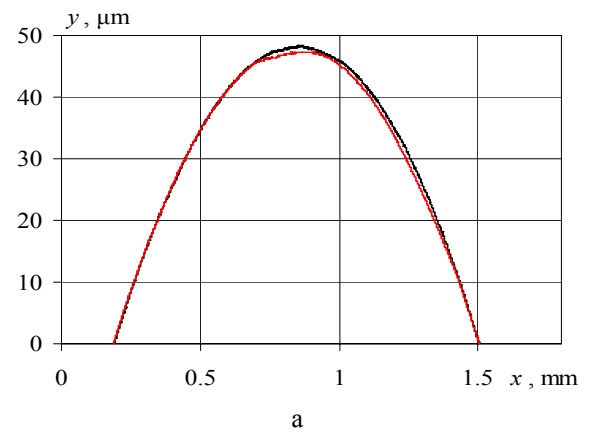
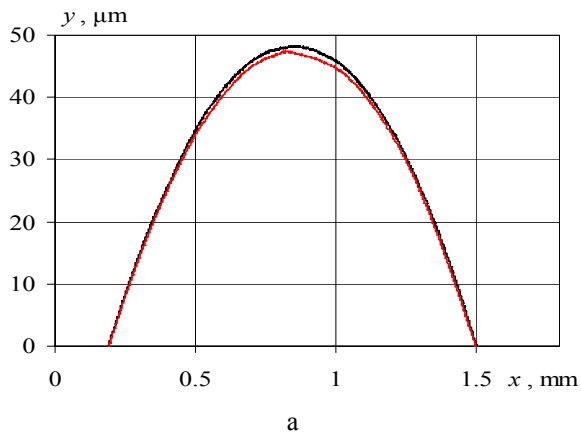

Fig. 7 Profilegrams of the front of a rod: a - rod having modified surface AK; b - reference rod

Fig. 9 Profilegrams of the rear of a rod: a - rod having modified surface AK; b - reference rod

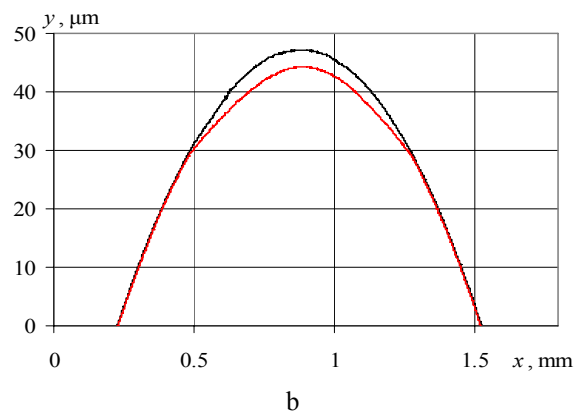
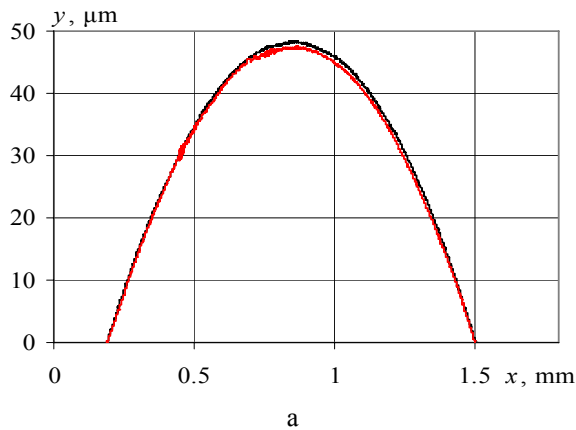

Fig. 8 Profilegrams of the middle of a rod : a - rod having modified surface AK; b - reference rod

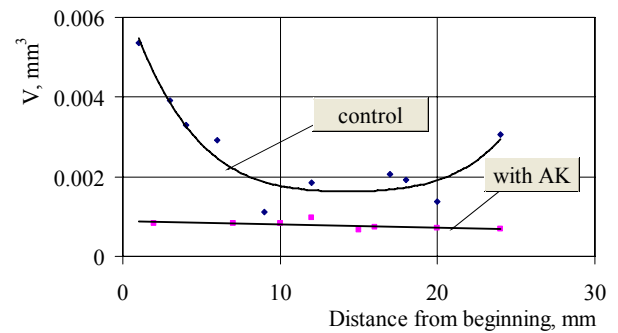
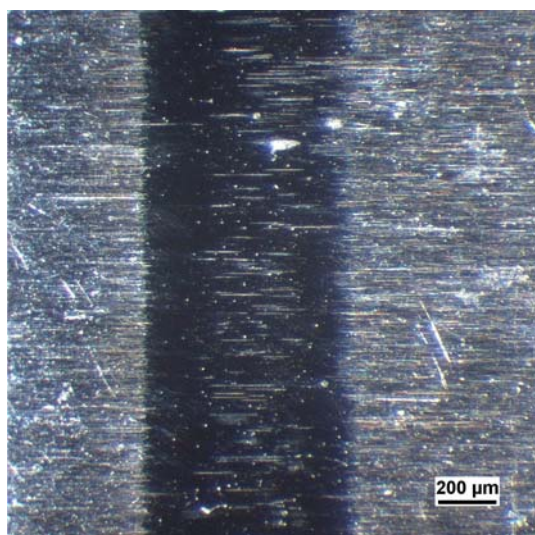

Fig. 10 Wear-out spread along the worn cross-section area in the rod length

Fig. 11 presents the photographs of the worn zones of modified and reference rods. We see that the wear-out zone of a modified rod is narrower and more even. It confirms the prior experiments made on less and more even wear-out of the modified rods.

Fig. 12 presents the wear-out data of medium modified and reference rods from worn material volume V . It shows that the modification of friction surfaces by fluoroligomer AK makes it possible to reduce the wear-out about three times. Summing up we can say that general less wear-out of the modified rods, if compared to the reference ones, is not only because it is slow, but because they wear more evenly.



a

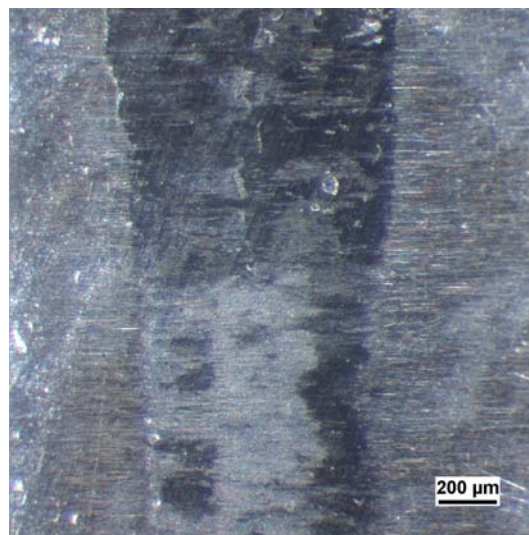

b

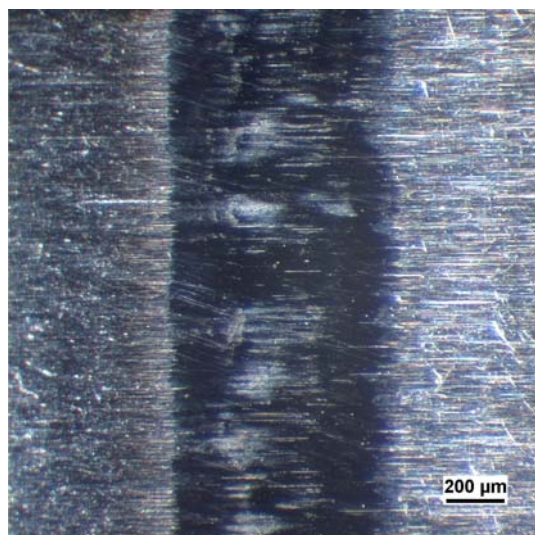

c

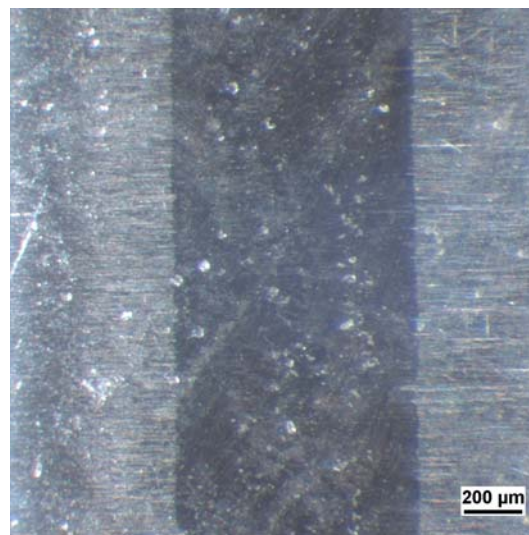

d

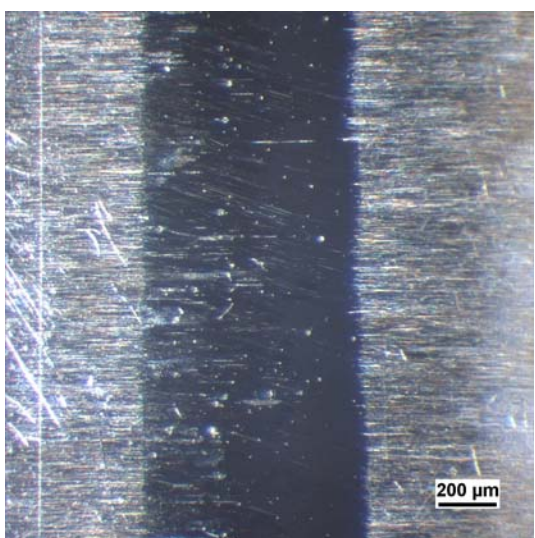

e

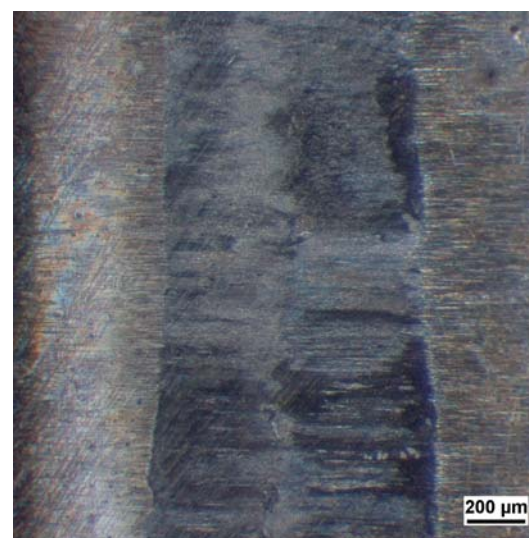

f

Fig. 11 Photograph of a rod: a, c, e - rod with modified surface AK; b, d, f - reference rod; a, b - front of the rod; c, d - middle of the rod; e, f - rear of the rod

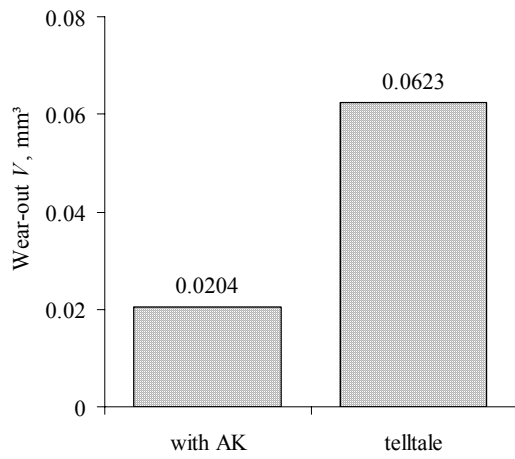
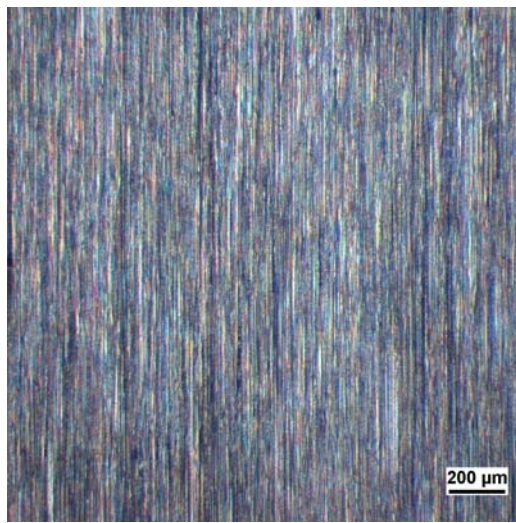

Fig. 12 Volume of worn material

The reason of less and more even wear-out is revealed in the work-in period when, due to fluor-oligomer treatment, the friction conditions of friction couples do not change with an increase in load, i.e. the coefficient of friction remains almost constant.

Fig. 13 presents the photographs of worn zones of modified and reference cylinders. They show that in both zones of small and heavy loads of a modified cylinder the wear-out traces are vaguely visible, while in the zone of small loads of a reference cylinder there are no wear out traces, however in the heavy load zone the adhesive wear-out is visible.



a

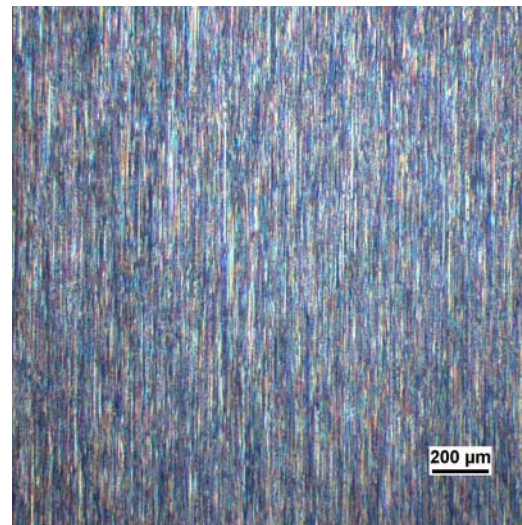

b

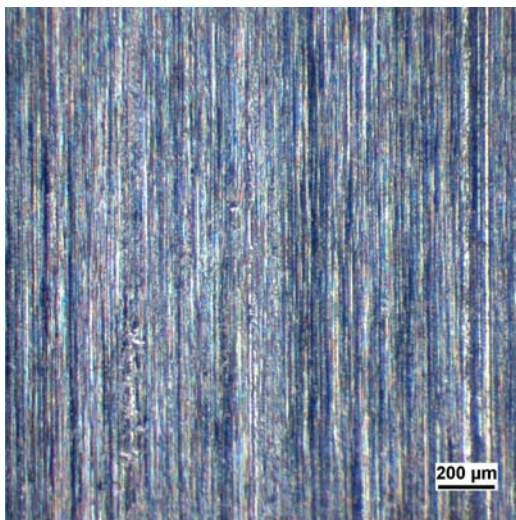

c

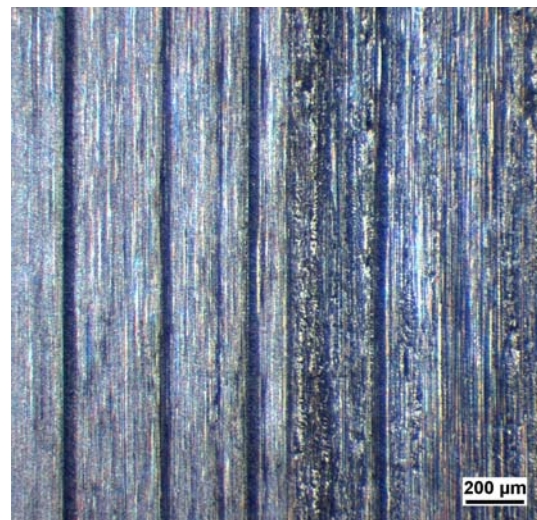

d

Fig. 13 Photograph of a cylinder: a - small load zone of a cylinder having modified surface AK; b - small load zone of a reference cylinder; c - heavy load zone of a modified cylinder; d - heavy load zone of a reference cylinder

5. Conclusions

The experiments made on reference surfaces and on surfaces modified with fluor-oligomer under varying load conditions have enabled us to determine.

1. Modification with fluor-oligomer has an essential effect on work-in of the surfaces: modified friction surfaces can effortlessly adjust to an increase in load. The modification has no essential effect on the magnitude of friction under steady working conditions.

2. The rods modified along their length wear-out more evenly than the reference ones. The average square deviation by a modified rod is $\sigma = 0.000128 \text{ mm}^3$, by a reference rod $\sigma = 0.00168 \text{ mm}^3$.

3. Wear-out of modified surfaces compared to the volume of worn rod material is on the average 3.0 times lower.

References

1. **Thiessen K.P., Winkler E., Noack U.** Niedriger Reibwert durch fluorhaltige Reaktionsschichten.- Tribologie+Schmierungstechnik, 1997, No5, s.203-207.
2. **Padgurskas, J., Rukuiža, R., Votter, M., Wollesen, V.** New tribotechnical materials for the friction pair radial lip seal.-Industrial Lubrication and Tribology, 1999, v.51, No5, p.233-238.
3. **Milvydas A., Padgurskas J., Prosyčevs I., Guobienė A.** Fluoro oligomerų dangų formavimas ant paviršių.-Proc. of the Int. Conf. "Mechanika-2002".-Kaunas: Technologija, 2002, p.61-66.
4. **Padgurskas J., Feldmann D.G.** Untersuchung der Tribologischen Eigenschaften von Hydraulikflüssigkeiten.-Agricultural Engineering: Research papers/ LZŪU ŽŪII.-2005, Nr.37(1), p.110-123.

J. Padgurskas, Š. Skirka

FLUORO OLIGOMERŲ ĮTAKA TRINTIES PORŲ TRIBOTECHNINĖMS SAVYBĖMS KINTAMOS APKROVOS SĄLYGOMIS

Re z i u m ė

Straipsnyje nagrinėjama fluoro oligomerų įtaka trinties porų „plienas-plienas“ tribotechninėms savybėms

kintamos apkrovos sąlygomis. Parodyta, kad nudilimas turi būti vertinamas pagal nudilusios medžiagos tūrį. Nustatyta, kad trinties paviršių sustiprinimas fluoro oligomerais turi esminę įtaką įdirbimo procesui ir paviršių dilimui: sustiprinti paviršiai lengviau prisitaiko prie apkrovų padidinimo, mažiau ir tolygiau dyla.

J. Padgurskas, Š. Skirka

EFFECT OF FLUOR-OLIGOMER ON TRIBOLOGICAL PROPERTIES OF FRICTION COUPLES UNDER VARYING LOADS

S u m m a r y

The paper analyses the influence of fluor-oligomer on the tribological properties of friction pairs "steel-steel" under varying loads. It was proved that the wear should be evaluated according the volume of worn material. The strengthening of friction surface with fluor-oligomer has subsistent impact on the running-in process and surface wear: strengthened surface adapts easier to increased loads, wears less and more even.

Ю. Падгурскас, Ш. Скирка

ВЛИЯНИЕ ФТОРСОДЕРЖАЩИХ ОЛИГОМЕРОВ НА ТРИБОТЕХНИЧЕСКИЕ СВОЙСТВА ПАРЫ ТРЕНИЯ В УСЛОВИЯХ ПЕРЕМЕННОЙ НАГРУЗКИ

Р е з ю м е

В статье приведены результаты исследований влияния фторсодержащих олигомеров на триботехнические свойства пары трения «сталь-сталь» в условиях переменной нагрузки. Показано, что износ нужно оценивать по объему стертого материала. Установлено, что упрочнение поверхностей трения фторсодержащими олигомерами имеет существенное влияние на процесс приработки и износ поверхностей: упрочненные поверхности легче приспособляются к повышению нагрузок, меньше и равномернее изнашиваются.

Received March 21, 2005

DOI: 10.5755/j02.mech.14526