

Determination of heat transfer intensity in laminar liquid film flow

S. Šinkūnas*, A. Kiela**, I. Gimbutytė***, K. Šinkūnas****

*Kaunas University of Technology, Donelaičio 20, 44239 Kaunas, Lithuania, E-mail: stasys.sinkunas@ktu.lt

**Kaunas College, Pramonės 22, 50387 Kaunas, Lithuania, E-mail: algimantas.kiela@tm.kauko.lt

***Kaunas University of Technology, Donelaičio 20, 44239 Kaunas, Lithuania

****California University, Berkeley, USA, E-mail: kestin@nuc.berkeley.edu

Nomenclature

a - thermal diffusivity, m^2/s ; b - elementary width of the film; c - specific heat, $J/(kg \cdot K)$; C_{nq} - heat transfer correction factor; d - hydraulic diameter of the film, m ; g - acceleration of gravity, m/s^2 ; Ga_R - Galileo number, gR^3/ν ; Nu - Nusselt number, $\alpha\delta/\lambda$; Nu_d - Nusselt number, $\alpha d/\lambda$; Nu_M - modified Nusselt number, $(\alpha/\lambda)(\nu^2/g)$; Pe - Peclet number, $(Re \cdot Pr)$; Pr - Prandtl number, ν/a ; q - heat flux density, W/m^2 ; R - cross curvature of wetted surface (tube external radius), m ; Re - Reynolds number of liquid film, $4\Gamma/(\rho\nu)$; T - temperature, K ; w - film velocity, m/s ; x - longitudinal coordinate; y - distance from the wetted surface, m ; α - heat transfer coefficient, $W/(m^2 \cdot K)$; Γ - wetting density, $kg/(m \cdot s)$; δ - liquid film thickness, m ; ε_R - relative cross curvature of the film, δ/R ; ε_{pr} - multiplier for liquid physical properties; ε_q - ratio of heat flux densities, (q_s/q_w) ; μ - dynamic viscosity, $(Pa \cdot s)$; λ - thermal conductivity, $W/(m \cdot K)$; ν - kinematic viscosity, m^2/s ; ρ - liquid density, kg/m^3 ;

Subscripts: f - film flow; s - film surface; $stab$ - stabilized flow; t - thermal boundary layer; w - wetted surface.

1. Introduction

Prediction of heat transfer in liquid film flow is important in relation to various engineering aspects. Recently, it has been promoting to develop the high performance heat exchangers and other thermal installations for the effective use of energy. Refrigeration technology finds application in a large variety of heat transfer processes ranging from cooling of electronic devices to food processing. Even small improvements in heat transfer during technological processes may lead to significant energy and money savings. In practice, simple but reasonably accurate models, techniques and approaches for determining the temperature distributions and heat transfer parameters are highly preferred instead of the complex methods. The growing awareness of environmental problems recently draw the efforts of many researches, including the field of engineering, to evaluate systems on the basis of heat transfer phenomena. Heat transfer processes also affect the performance of propulsion systems such as the internal combustion, gas turbine and rocket engines.

Gravity liquid film flows occur in a wide variety of applications in chemical processing, power generation and energy production facilities. Some practical applications include condensers and boilers, gas-liquid reactors, wetted walls absorbers, falling films evaporators and core cooling in nuclear power plants under emergency conditions. In typical gasoline internal combustion engine oil film must be formed between the piston rings and the pis-

ton liner to prevent wear, to seal combustion chamber gases from the rest of the engine and to minimize friction losses. Finally, a film of oil must cover the engine bearings so that the metal surfaces in the bearings do not come into direct contact.

In heat transfer systems used in different fields of engineering a lot of the heat exchange equipments are designed to operate in laminar liquid film flow regimes [1, 2]. The heat transfer mechanism of a liquid film flowing down profiled horizontal tubes was studied in several works [3, 4]. A method of its enhancement based on the breakdown of the thermal boundary layer by longitudinal fins and grooves was developed. Results of the heat transfer research in evaporating falling films on a structured and smooth surface respectively are presented in [5, 6]. The obvious change of the wavy film structure by using a profiled heating surface showed the improvement of heat transfer coefficient. Hydrodynamic and thermal liquid film flow study on vertical plate with grids was performed in [7]. The conditions for an optimum heat transfer in evaporating water film driven by gravity down a vertical heated plate were established. It was evaluated the influence of wetted surface geometry and operating parameters on the heat transfer enhancement.

The heat transfer in thermal entrance region of vertical tubes was investigated in [8]. Experiments have shown that the thermal entrance region first decreases as the Raleigh number increases. Experimental investigations of heat transfer in the entrance region for turbulent film were carried out in [9]. It was found that Reynolds number and initial velocity of liquid film has a significant influence on local heat transfer. The heat transfer stabilization has been determined experimentally as well.

Despite of the fact that liquid film flow due to gravity forces is deeply analyzed, the methods that evaluate the heat transfer processes on vertical surface are not completely finished.

2. Heat transfer in laminar film flow on a vertical surface

Heat transfer across the liquid film takes place due to temperature difference between the wetted surface and the film. In the case of laminar film flow the conduction may be viewed as a mode of the heat transfer only. Thus, the equation known as Fourier's law can be used to compute the amount of energy being transferred per unit time

$$q = -\lambda \text{grad}T \quad (1)$$

By substituting the expression of temperature gradient in Eq. (1) and integrating, we obtain

$$\int_{T_w}^T dT = -\frac{q_w}{\lambda} \int_0^y \frac{q}{q_w} dy \quad (2)$$

and

$$T_w - T = \frac{q_w}{\lambda} \int_0^y \frac{q}{q_w} dy \quad (3)$$

The heat flux from a liquid film can be determined as follows

$$Q = cT_f \rho \bar{w} b \delta = \int_0^\delta cT \rho w b dy \quad (4)$$

The mean temperature can be defined as

$$T_f = \frac{\int_0^\delta w T dy}{\bar{w} \delta} \quad (5)$$

By substituting Eq. (3) in Eq. (5), we obtain

$$T_f = T_w - \frac{\frac{q_w}{\lambda} \int_0^\delta w \left(\int_0^y \frac{q}{q_w} dy \right) dy}{\bar{w} \delta} \quad (6)$$

By defining temperature difference between a wetted surface and the mean temperature of the film as

$$T_w - T_f = \frac{\frac{q_w}{\lambda} \int_0^\delta w \left(\int_0^y \frac{q}{q_w} dy \right) dy}{\bar{w} \delta} \quad (7)$$

we obtain the following expression for the calculation of local heat transfer coefficient

$$\alpha = \frac{\bar{w} \delta \lambda}{\int_0^\delta w \left(\int_0^y \frac{q}{q_w} dy \right) dy} \quad (8)$$

In order to define the regularity $q/q_w = f(y)$, we use the energy equation

$$c\rho w \frac{\partial T}{\partial x} + \frac{dq}{dy} = 0 \quad (9)$$

By integrating the Eq (9) within the limits from 0 to y , we obtain the ratio of heat flux densities in the film

$$\frac{q}{q_w} = 1 - \frac{c\rho}{q_w} \int_0^y w \frac{\partial T}{\partial x} dy \quad (10)$$

Assume that $\partial T/\partial x = dT_f/dx$ [10]. Then the ratio dT_f/dx can be determined by the equation of heat balance in the film

$$\frac{dT_f}{dx} = \frac{q_w}{c\rho \bar{w} \delta} \quad (11)$$

Substituting Eq. (11) in Eq. (10) leads to the following relationship

$$\frac{q}{q_w} = 1 - \frac{\int_0^y w dy}{\bar{w} \delta} \quad (12)$$

By substituting Eq. (12) in Eq. (8) and by employing the Nusselt number Nu_d , we obtain

$$Nu = \frac{\bar{w} \delta \alpha}{\int_0^\delta w \left(\int_0^y \left(1 - \frac{\int_0^y w dy}{\bar{w} \delta} \right) dy \right) dy} \quad (13)$$

Velocity in the laminar film flow one can calculate by the following equation

$$w = \frac{g\delta y}{\nu} \left(1 - 0.5 \frac{y}{\delta} \right) \quad (14)$$

and the mean velocity respectively

$$\bar{w} = \frac{g\delta^2}{3\nu} \quad (15)$$

Taking into account Eqs. (14) and (15), we obtain the following expression from Eq. (13)

$$Nu_d = \frac{8w_\delta \delta^2}{3 \int_0^\delta w \left(\int_0^y \left(1 - \frac{3 \int_0^y w dy}{2w_\delta} \right) dy \right) dy} \quad (16)$$

The above-mentioned equation could be solved numerically and the following result is obtained

$$Nu_d = 8.2353 \quad (17)$$

In case of heat transfer calculations, it is more reasonable to use modified Nusselt number Nu_M . Therefore, the following equation can be used

$$Nu_M = 2.27Re^{-1/3} \quad (18)$$

As it is shown in [11], the application of Eq. (18) can be expanded using the corresponding multipliers. The curvature of the film flowing down a vertical tube surface and heat transfer between the film surface and surrounding medium of a gas or vapour, can be evaluated by correction factor C_{Rq} . Multiplier ε_{Pr} may estimate the variability of liquid physical properties. Then, the modified Nusselt number can be calculated by the following equation

$$Nu_M = 2.27Re^{-1/3}C_{Rq}\varepsilon_{Pr} \quad (19)$$

The correction factor C_{Rq} can be determined by equations

$$C_{Rq} = \frac{136}{136 + 39\varepsilon_R} + (0.52 - 0.03\varepsilon_q)\varepsilon_R \quad (20)$$

when $q_w = const$
and

$$C_{Rq} = \frac{56}{56 + 10\varepsilon_q} + (0.58 - 0.05\varepsilon_q)\varepsilon_R \quad (21)$$

when $T_w = const$.

The variations of correction factor C_{Rq} upon the range of relative cross curvature and external heat exchange between the film surface and surrounding medium according to Eqs. (20) and (21) are shown in Fig. 1.

The variation of physical properties of the liquid across the film must be taken into account in a case of high value of temperature difference. The multiplier ε_{Pr} in Eq. (19) can be determined as an exponential function of the following ratios Pr_f/Pr_w or μ_f/μ_w . The results of numerical calculations showed that ratio Pr_f/Pr_w unambiguously does not evaluate the influence of physical properties variation for different liquids and the character of this influence practically is not dependent upon the values of ε_q and ε_R . This research showed that for $-0.5 \leq \varepsilon_R \leq -1$ and $0.4 \leq Pr_f/Pr_w \leq 2$ the multiplier $(Pr_f/Pr_w)^{0.25}$. The multiplier ε_{Pr} must be determined as a function of parameters μ_f/μ_w for more accurate evaluation of liquid physical properties variation. This parameter evaluates practically the influence of physical properties variation for water, transformer oil, fuel oil and compressor oil. The multiplier ε_{Pr} in such case can be calculated by the equation

$$\varepsilon_{Pr} = (\mu_f/\mu_w)^n \quad (22)$$

where $n = 0.315(2 + \varepsilon_R)^{-0.49}$, for $0.1 \leq \mu_f/\mu_w \leq 1$ and $n = 0.325(2 + \varepsilon_R)^{-0.24}$, for $1 \leq \mu_f/\mu_w \leq 10$. The similar data in [11] for $\varepsilon_R = 0$ have showed that boundary conditions on the wetted surface have no influence to the character of heat transfer dependence on variability of the liquid physical properties.

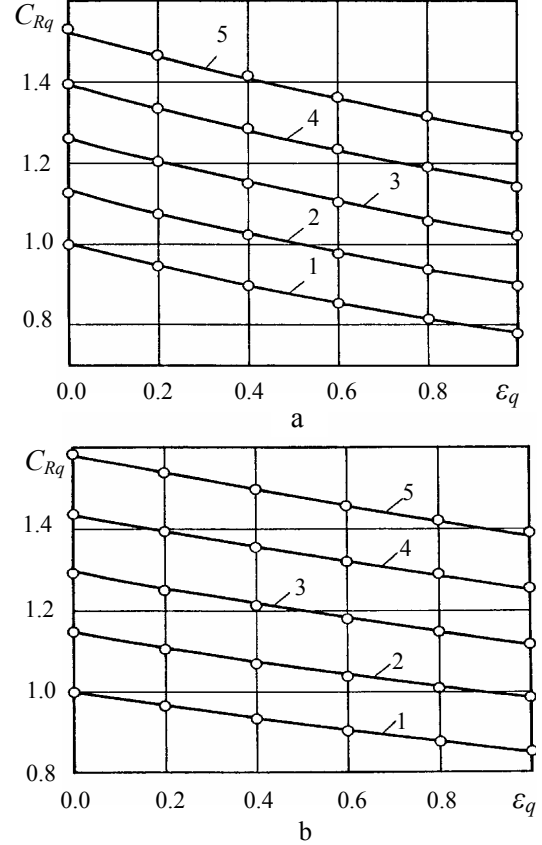

Fig. 1 Variations of correction factor on film cross curvature and external heat transfer: a - boundary condition $q_w = const$ and b - boundary condition $T_w = const$ 1-5 - $\varepsilon_R = 0; 0.25; 0.50; 0.75$ and 1.0 correspondingly

3. Experimental set-up and procedure

The scheme of experimental set-up is presented in Fig. 2. Transformer oil was used as working liquid and with the aid of feed pump it has been supplied to the liquid tank, which includes a slot distributive mechanism. The oil film from the distributor fell down a vertical tube (calorimeter). The stainless steel tube 3.8 mm in outside diameter with the length of 546 mm was used in the experiment as a calorimeter. The fixing bolts at the end of tested tube allowed the possibility to regulate and to guarantee verticality of the tube. After flowing down the calorimeter, transformer oil was gathered back to the reservoir. The gutter at calorimeter end ensured a smooth falling of the oil into the reservoir. The temperature of falling down film was measured by two calibrated thermocouples. The location of thermocouple in the liquid distributor ensured the measurement of oil film temperature in the inlet. The thermocouple installed at the end of calorimeter determined oil film temperature at the exit correspondingly. In order to keep the necessary temperature of transformer oil the cooler was installed in the reservoir.

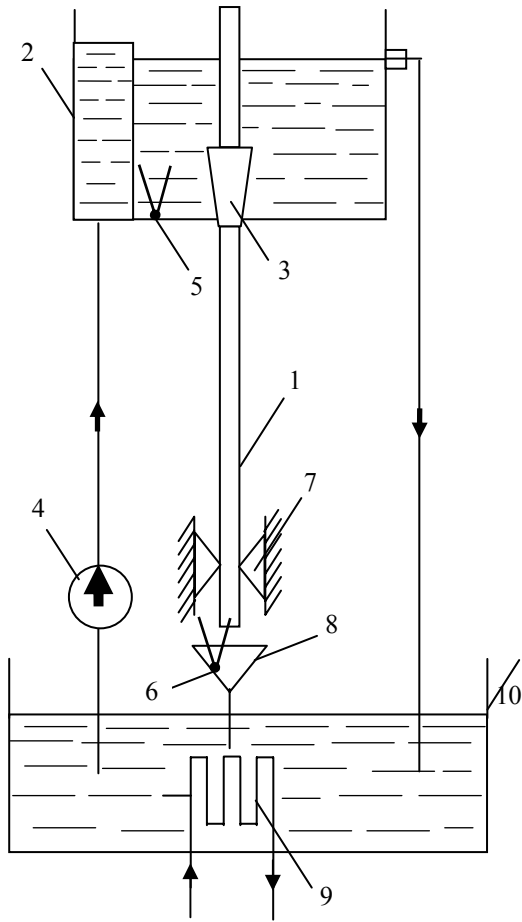

Fig. 2 Schematic diagram of experimental set-up: 1 - calorimeter; 2 - liquid tank; 3 - slot distributive mechanism; 4 - feed-pump; 5 - inlet thermocouple; 6 - outlet thermocouple; 7 - centring bolts; 8 - gutter; 9 - cooler; 10 - liquid reservoir

As heat flux along the tested section did not change, so to the demanded accuracy of the experiment it was assumed that the bulk mean temperature of the liquid film conform linear regularity. That circumstance allowed determining the oil film temperature at any cross-section of the tested section accurately. Measurement accuracy for the determination of film flow parameters was of the range 2.5 - 7.1%.

For the heat transfer research of falling down transformer oil film on the surface of vertical tube the electric circuit (Fig. 3) was applied.

The electric current supplied for the calorimeter provided a steady heat flux on the experimental section. The current could have been ranged from 300 to 500 amperes and voltage from 5 to 10 volts respectively. In order to convert an alternating current into a direct current the rectifier was used. Voltages drop on the known value resistor fitted in as a shunt determined the electric strength in the circuit. Its readings were taken from the millivoltmeter. Voltage value on the calorimeter was measured by voltmeter. The resistance of the test section has come to 0.012 ohm/m, while the resistance of transformer oil film did not exceed $36 \cdot 10^6$ ohm/m respectively. So, the heat dissipation within the oil film was ignored on the assumption that the whole heat flux determined by voltage drop and current has been carried through the surface of tested section exclusively.

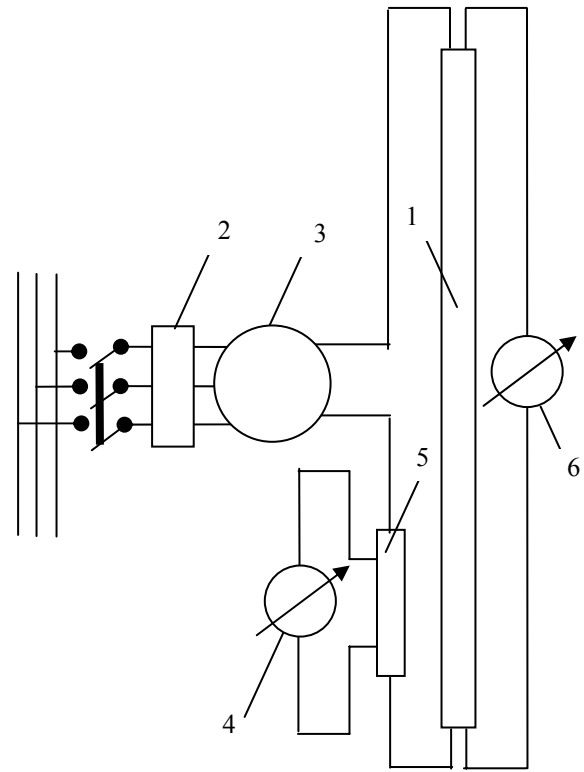

Fig. 3 Electric circuit: 1 - calorimeter; 2 - voltage regulator; 3 - rectifier; 4 - millivoltmeter; 5 - shunt; 6 - voltmeter

4. Heat transfer in the thermal entrance region of liquid film flow

Heat transfer in the entrance region was studied experimentally for boundary condition $q_w = const$. The results were obtained for the film flow of transformer oil on vertical stainless tube with outside diameter 3.8 mm. The length of the test tube was equal 546 mm. The experiments were provided in presence and absence of isothermal section with 105 mm length.

The considerable relative curvature ε_R for laminar or wavy-laminar film flow is possible with high viscosity liquid or with high Prandtl number. In such case the thermal entrance region is much longer than hydrodynamic one.

The results of local heat transfer coefficient in the entrance region for laminar film flow on vertical plane surface can be determined by the expression [12]

$$Nu_{df} = 8.24 \left[1 + 0.0011 (Pe_f d/x)^{4/3} \right]^{1/4} (Pr_f / Pr_w)^{1/4} \quad (23)$$

For stabilized heat transfer, evaluating the cross curvature of wetted surface, Eq. (23) can be written as follows

$$Nu_{df} = 8.24 C_{Rq} (Pr_f / Pr_w)^{1/4} \quad (24)$$

In this case the thickness of thermal boundary layer is equal to the film thickness and can be determined [13] by the following equation

$$\delta = 1.67 R \sqrt{1 + 1.09 (Re / Ga_R)^{1/3}} - 1 \quad (25)$$

For laminar film flow we can assume that local heat transfer coefficient is inversely proportional to the thickness of thermal boundary layer $\alpha/\alpha_{stab} = \delta/\delta_t$. Taking this precondition into account, from Eq. (23) and (24) it follows that

$$\frac{\delta_t}{\delta} = \frac{\alpha_{stab}}{\alpha} = \left[1 + 0.0011(Pe_f d/x)^{4/3}\right]^{-1/4} \quad (26)$$

On this correlation basis, the relative cross curvature of the laminar film one can express as follows

$$\varepsilon_R = \frac{\delta}{R} \left[1 + 0.0011(Pe_f d/x)^{4/3}\right]^{-1/4} \quad (27)$$

In absence of external heat transfer ($q_s = 0$), the correction factor evaluates the film curvature

$$C_{Rq} = C_R = 1 + 0.52\varepsilon_R \quad (28)$$

External heat transfer does not influence the heat transfer intensity in the thermal entrance region and Eq. (27) is valid. The local heat transfer coefficient in the thermal entrance region for the laminar film falling down outside surface of vertical tube can be determined by the following equation

$$Nu_{df} = 8.24 \left[1 + 0.0011(Pe_f d/x)^{4/3}\right]^{1/4} \times C_R (Pr_f/Pr_w)^{1/4} \quad (29)$$

The comparison of theoretical results obtained by Eq. (29) with experimental data is presented in Fig. 4. As we can see, the experimental results are in good agreement with Eq. (29).

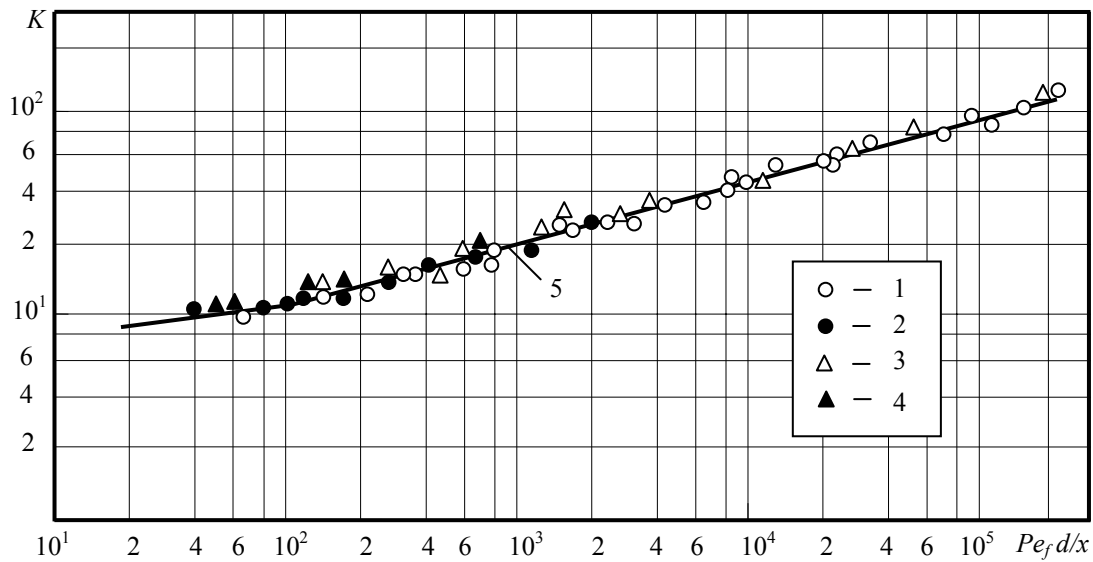

Fig. 4 Experimental results of local heat transfer: 1,2 - laminar and wavy-laminar flow in absence of the isothermal section correspondingly; 3,4 - laminar and wavy-laminar flow in presence of the isothermal section; 5 - equation (29); $K = Nu_{df} C_R^{-1} (Pr_w/Pr_f)^{1/4}$

5. Conclusions

1. The cross curvature and external exchange of the film has a significant influence on heat transfer rate from the wetted surface in laminar gravitational liquid film flowing down the outside surface of vertical tube. The equation for the heat transfer calculation of laminar liquid film falling down a plane vertical surface complemented by multipliers C_{Rq} evaluating curvature of the film and ε_{Pr} evaluating the variability of liquid physical properties respectively has been established.

2. The experimental results showed that surface cross curvature has a significant influence on the local heat transfer in the thermal entrance region of high viscosity liquid film flow. The values of local heat transfer coefficient increases with the increase of relative cross curvature of the film flowing down outside vertical tube surface. The comparison of experimental data with the results of theoretical calculations has showed a good agreement between themselves.

3. The results of the research can be applied in engineering calculations for heat exchange apparatus design evaluating liquid film cross curvature and external heat transfer exchange.

References

1. **Kakac, S., Shan, R.K., Aung, W.** Handbook of single phase convective heat transfer. -New York: John Wiley & Sons, Inc, 1987. -2241p.
2. **Martzeniuk, A.C., Stabnikov, V.U.** Film heat and mass transfer apparatus in a food processing industry. - Moscow: Light and food Processing Industry, 1991. -327p.
3. **Rifert, V., Sidorenko, V., Usenko, V., Zolotukhin, I.** Methodic of measurements and experimental results of local heat transfer at liquid film flow on the horizontal finned tubes. -5th World Conf. on Experimental Heat Transfer, Fluids Mechanics and Thermodynamics, 24-28 September, Thessaloniki, Greece, 2001, v.3, p.1997-2000.

4. **Rifert, V., Putilin, J., Podbereznyi, V.** Evaporation heat transfer in liquid films flowing down horizontal smooth and longitudinally profiled tubes. -J. of Enhanced Heat Transfer, 2001, v.8, p.91-97.
5. **Lozano Aviles, M., Maun, A.H., Iversen, V., Aueracher, H., Wozny, G.** High frequency needle probes for time-and-space characteristics measurements of falling films on smooth and enhanced surfaces. -6th World Conf. on Experimental Heat Transfer, Fluids Mechanics and Thermodynamics, 17-21 April, Matsu-shima, Miyagi, Japan, 2005, v.1, p.1-5.
6. **Takase, K., Yoshida, H., Ose, Y.** Predicted thermal-hydraulic characteristics of liquid film flow on ribbed surface. -1st Int. Forum on Heat Transfer, 24-26 November, Kyoto, Japan, 2005, v.1, p.207-208.
7. **Mitrovic, J., Raach, H.** Hydrodynamic and thermal film flow study on vertical plates with grids. -Report on the Progress of Easy MED Workpage 2 for the Tip, 29th January, 2004, Institute for Energy and Process Engineering University of Paderborn, Germany, p.1-4.
8. **Marner, W.J., McMillan, H.K.** Combined free and forced laminar convection in a vertical tube with constant wall temperature. -J. Heat Transfer, 1970, v.92, p.559-562.
9. **Sinkunas, S., Gyls, J., Kiela, A.** Experimental study of momentum and heat transfer in the entrance region of vertical film flow. -12th Int. Conf. on Computational Methods and Experimental Measurements, 20-22 June, Malta, 2005, v.41, p.879-888.
10. **Kays, W.M.** Convective heat and mass transfer. - Moscow: Energy, 1972. -446 p.
11. **Gimbutis, G., Gimbutyte, I., Sinkunas, S.** Heat transfer in a falling liquid film with large curvature. -Heat Transfer Research, Scripta Technika, 1993, v.25(2), p.216-219.
12. **Gimbutis, G., Gimbutyte, I., Sinkunas, S.** Heat transfer of a falling liquid film under different heat flux distribution in the film. -Transport Processes in Engineering, 1992, v.2, p.1177-1188.
13. **Гимбутис Г.И.** Теплообмен при гравитационном течении пленки жидкости. -Вильнюс: Мокслас, 1988. -233с.

S. Šinkūnas, A. Kiela, I. Gimbutytė, K. Šinkūnas

ŠILUMOS PERNEŠIMO, ESANT LAMINARINIAM SKYSČIO PLĖVELĖS TEKĖJIMUI, TYRIMAS

R e z i u m ė

Teoriškai išnagrinėtas stabilizuotas šilumos pernešimas, esant laminariniam skysčio plėvelės tekėjimui.

Pateikta laminarinės plėvelės, tekančios vertikaliu paviršiumi, vietinio šilumos atidavimo skaičiavimo metodika. Nustatyta drėkinamojo paviršiaus kreivumo ir išorinių šilumos mainų įtaka šilumos pernešimui skysčio plėvelėje. Eksperimentiškai išnagrinėtas šilumos atidavimas pradiniam terminiam laminarinės plėvelės tekėjimo ruože, nustatyta paviršiaus kreivumo įtaka šilumos mainams pradiniam terminiam ruože, tekant didelės klampos skysčio plėvelei.

S. Šinkūnas, A. Kiela, I. Gimbutytė, K. Šinkūnas

DETERMINATION OF HEAT TRANSFER INTENSITY IN LAMINAR LIQUID FILM FLOW

S u m m a r y

Analytical study of the stabilized heat transfer for the laminar liquid film flow was carried out. The method for the calculation of local heat transfer in laminar film flowing down a vertical surface was proposed. The wetted surface curvature and external heat exchange influence on heat transfer in laminar film was established analytically. Experimental investigation of heat transfer in thermal entrance region for laminar film was performed as well. The surface cross curvature influence on the local transfer in the thermal entrance region of high viscosity liquid film flow was established experimentally.

С. Шинкунас, А. Кела, И. Гимбутите, К. Шинкунас

ОПРЕДЕЛЕНИЕ ПЕРЕНОСА ТЕПЛА ПРИ ЛАМИНАРНОМ ТЕЧЕНИИ ПЛЕНКИ ЖИДКОСТИ

Р е з ю м е

Проведен теоретический анализ стабилизированного теплообмена при ламинарном течении пленки жидкости. Предложена методика для определения локальной теплоотдачи при течении ламинарной пленки по вертикальной поверхности. Определено влияние поперечной кривизны орошаемой поверхности и наружной теплоотдачи на теплообмен в ламинарной пленке. Также проведено экспериментальное исследование теплообмена в начальном термическом участке при ламинарном течении пленки жидкости. На основе полученных данных определено влияние поперечной кривизны поверхности на теплоперенос в пленке жидкости с большой вязкостью.

Received April 22, 2005

DOI: 10.5755/j02.mech.14527