

Vibration isolating couplings for operation in various excitation motions

B. Spruogis*, **A. Jakštas****

*Vilnius Gediminas Technical University, Plytinės 27, 10105 Vilnius, Lithuania, E-mail: bs@ti.vtu.lt

**Vilnius Gediminas Technical University, Basanavičiaus 28, 03224 Vilnius, Lithuania, E-mail: arunas@me.vtu.lt

1. Introduction

Vibration isolation of a torsional system is strongly dependent on the flexibility and dissipating characteristics of couplings linking various units of mechanisms. Modern equipment require the accuracy of motion and are characterized by a wide range of rotational disturbance. However, couplings with invariable characteristics can hardly provide good vibration isolation. Therefore, couplings with characteristics variations depending on loading have been more often used lately. Such couplings are more suitable for drives operating under varying loading in particular modes of operation. Moreover, the requirements which couplings have to satisfy are also changing depending on loading. When the motion is accurate and loading is not high, a unit should have some flexibility. Under full-load conditions, the main requirement is strength of structural elements.

Recently, efforts have been made to use couplings with the characteristics changing depending on operational conditions. Thus, in [1] is presented the possibility to render nearly constant the dynamic behavior of multi-articulated flexible structures by using adaptive controller based on the operation in parallel of a finite Gaussian quadratic linears controllers.

In [2] the use of hollow bars made of special carbon composite materials as torsion transmitting flexible elements is considered. Due to the variable shape of a deformed element, its rigidity may also be varied. The carrying capacity of couplings may vary if the magneto-rheological liquid is kept between the parallel surfaces of the driving and the driven half-couplings [3]. However, in this case, torsional coupling rigidity varies but slightly, with vibration isolation being insufficient when the unit is running at variable disturbance frequency.

The present paper considers couplings of relatively simple types allowing, however, for their carrying capacity and torsional rigidity to be changed. This aspect makes the above couplings preferable for the use in technological equipment operating under varying conditions.

2. Couplings with flexible ring elements

In this type of couplings torque is transmitted via a ring connected with a hinge to the driving and driven half-couplings. When the torque reaches a particular magnitude a flexible member is either unloaded or its deformation conditions are changed.

In the first case (Fig. 1), the coupling is a combination of the ring and tooth-type couplings.

When the torque is small, the loading is transmitted via a flexible ring. A distinctive feature of the engage-

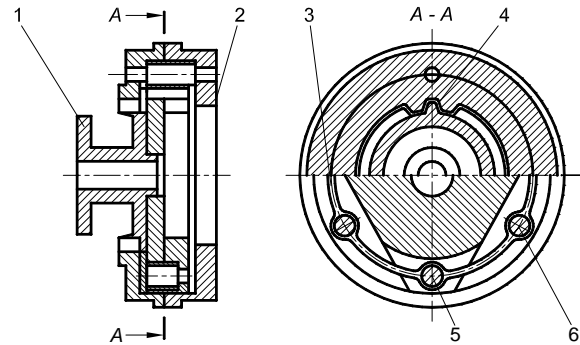

Fig. 1 Schematic diagram of a tooth-type ring coupling
1- driving half-coupling, 2 - driven half-coupling,
3 - flexible ring, 4 - tooth gearing, 5 - pin connecting the ring with the driving half-coupling, 6 - pin connecting the ring with the driven half-coupling

ment used in this coupling compared to commonly used mesh is the absence of every other tooth of the rings. Half-couplings are arranged in such a way that, when not loaded, teeth may engage only when the torque achieves a particular value because the gap between them is the largest at that time. When the torque is being transmitted normal stresses occur in the ring due to the following factors:

- a) bending moment caused by useful load

$$M_B = a M_T \quad (1)$$

here a coefficient depending on the number of pins n uniformly spaced in any half-coupling (e.g., $a = 0.00909$ when $n = 2$; $a = 0.0245$ when $n = 3$), M_T is torque transmitted by the coupling;

- b) longitudinal strength of the pin

$$N_{ar} = \frac{M_T}{2\pi R} \quad (2)$$

here R is pins arrangement radius;

c) bending moment occurring due to the action of centrifugal forces of the ring [4, 5]

$$M_{BL} = \left(\frac{1}{2\alpha} - \frac{1}{2\sin\alpha} - \frac{1}{2} \operatorname{tg} \frac{\alpha}{2} \right) \chi R \quad (3)$$

here $\alpha = \pi/n$,

$$\chi = \frac{qR^2\omega^2}{B_1 + \frac{AR^2}{I_x} B_2} \quad (4)$$

χ is radial reaction in the pins; q is length unit mass of the ring; ω is the rate of coupling revolution; A is cross-section area of the rings; I_x is inertia moment of the ring cross-section with respect to the central axis perpendicular to the ring plane; B_1 and B_2 are coefficients dependent on n ($B_1 = 0.3926$, $B_2 = 0.0744$ when $n = 2$; $B_1 = 0.4933$, $B_2 = 0.05708$ when $n = 3$).

d) longitudinal strength of the ring due to the action of centrifugal forces

$$N_{LC} = qR^2\omega^2 - \frac{\chi}{2} \operatorname{ctg} \frac{\alpha}{2} \quad (5)$$

The highest stresses in the ring occur at the point of its connection with the pins of the driving coupling, therefore the condition of the ring strength is as follows

$$\sigma = \frac{M_I + M_{BL}}{W_x} + \frac{N_{LC} - N_L}{A} \leq \sigma_{adm} \quad (6)$$

where W_x is section modulus of the ring, σ_{adm} is allowable bending stresses of the ring.

Torsional rigidity of the ring is

$$C_R = b \frac{EI_x}{R} \quad (7)$$

where b is n -dependent coefficient ($b = 52.9$ when $n = 2$; $b = 463$ when $n = 3$), E is elasticity modulus of the ring material.

It is clear that to use the ring most efficiently providing minimum rigidity, M_T should slightly exceed the value at which the teeth engage. Following this, we will get the relationship for determining structural parameters of the ring

$$\frac{\sigma_{adm} W_x R}{abEI_x} = k \frac{\pi}{z_f} \quad (8)$$

where k is safety factor assumed to be equal to 1.2 - 1.5; $z_f = d/m$; d , m are pitch diameter and tooth engagement modulus the parameters of which are determined by well-known relationships taking into consideration the condition of maximum torque transmission.

To reduce axial coupling rigidity, the ring is made of separate sheets. In the case when the mode is shifted by changing the conditions of ring deformation, some additional supports preventing the extended parts of a flexible member to approach its revolution axis too closely are introduced in the coupling (Fig. 2). The shape of the supports is made similar to that of the extended parts in order to enlarge contact area with the ring. As a result, bending moment due to the action of circular force is considerably reduced, while carrying capacity of the coupling is increased by an order or so because most of the flexible ring stresses are bending stresses caused as described above. When the contact is established the increasing circular force causes only tensile stresses.

To determine the support profile, the displacement of the driving half-coupling pins and radial displacement of the middle points of the stretched ring arcs should

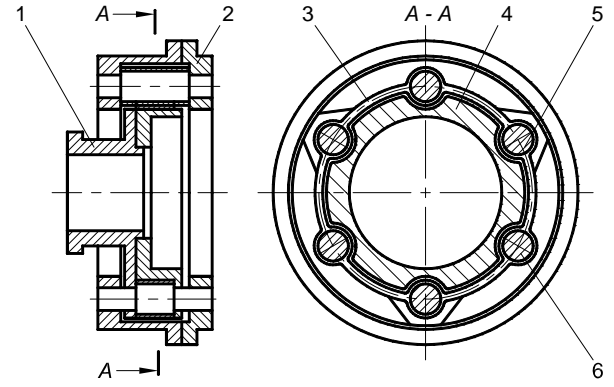

Fig. 2 Schematic diagram of a coupling with additional supports: 1 - driving half-coupling; 2 - driven half-coupling; 3 - flexible ring; 4 - additional support; 5 - pin connecting the ring with the driving half-coupling; 6 - pin connecting the ring with the driven half-coupling

be found. The latter are calculated by a fictitious force method based on the curved rods theory implying that the deformation of only one sixth of the ring circumference under the action of the circular force T and radial force F applied to the middle of the arc is considered. The displacement in the direction of force F is expressed by

$$\delta_p = \frac{E^3}{EI_x} (0.00699T - 0.0453F) \quad (9)$$

When $F = 0$, we will get the displacement of the middle ring section when it comes in contact with the support (when changing to the second mode at the specified load). The same relationship may be used in determining approximate interacting force of the ring and the support because friction forces affecting the performance of the coupling in the second mode are created by it.

The analysis of operational conditions of the coupling has shown that if the arc bears against the support along its full length, the compensatory mechanisms are less effective, while the ring load is increased. Therefore, the contact area corresponding 0.3 - 0.5 of extended arc length may be considered as the most appropriate. In coupling design radial displacement of the arc section may be assumed to be proportional to the section distance from the axis of the connecting pin, while restricting the profile of the middle support section to the circumference with the radius easily determined by simple geometric calculations.

When the coupling considered is used in high-speed drives the ring itself may increase disbalance because of the variation of its cross-section dimensions within the tolerances. The effect of ring deformation on centrifugal forces should be estimated. When the extended and compressed segments of a third of the ring length are individually considered, the following corrected values are obtained for centrifugal forces (Fig. 3)

$$\left. \begin{aligned} F_{CS} &= 0.0929 \frac{\pi R^4 \rho A \omega^2 T}{EI_x} \\ F_{CR} &= 0.11689 \frac{\pi R^4 \rho A \omega^2 T}{EI_x} \end{aligned} \right\} \quad (10)$$

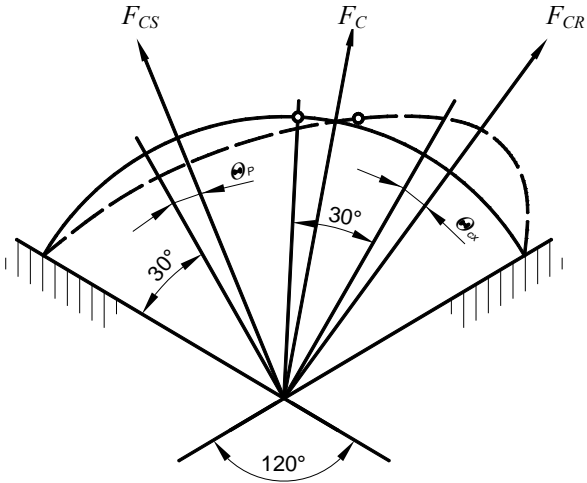

Fig. 3 Centrifugal forces acting in the deformed portion of the ring

Calculations of rotation rate and the ring length made with different applied loads have shown that various deviation angles of the loads resultant centrifugal forces from the middle of respective arcs have low effect, therefore the resultant of centrifugal forces of one third of the ring length may be obtained following the rule of vector summation of forces F_{it} and F_{ign} and assuming the angle between them to be 120° . This means that

$$F_C = 0.1672 \frac{\pi R^4 \rho A \omega^2 T}{EI_x} \quad (11)$$

3. Coupling with arched members

In this coupling (Fig. 4) the driving and driven half-couplings 1,2 are linked by flexible arc members 3 attached to half-couplings by pins 4,5.

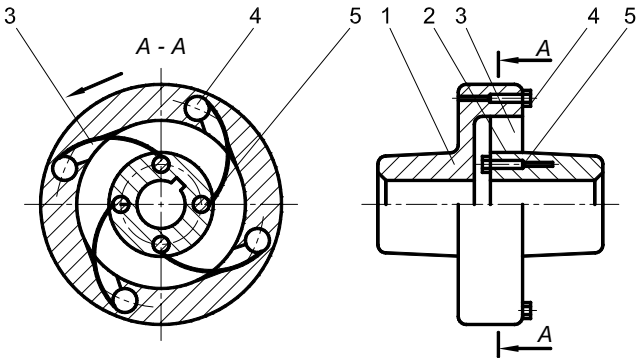

Fig. 4 Diagram of the coupling with arched flexible members: 1 - driving half-coupling; 2 - driven half-coupling; 3 - arched flexible member; 4 - pin connecting arched flexible member with the driving half-coupling; 5 - pin connecting arched flexible member with the driven half-coupling

The pins of the connection are located in the depressions of half-couplings, therefore, when the angle of torsion exceeds a particular value, some of the arcs rest against the depression edge decreasing in length. As a result, the rigidity of the coupling is increased. To reduce the load on a flexible member when a torque is transmitted,

the radius of pins arrangement on the driving half-coupling should be larger than that of the driven half-coupling.

In Fig. 5, a computational scheme of one flexible member is presented. Circular force T is acting tangentially to the circle with the radius R . The same reaction in opposite direction is observed in the hinge A (i.e. at the connection point of the arc and the driven half-coupling). The following radial forces occur on the hinges

$$Q = T \frac{\sqrt{(2R_0 \sin \varphi/2)^2 - (r \sin \varphi)^2}}{r \sin \varphi} = Tg \quad (12)$$

where r is radius of pins arrangement on the driven half-coupling, R_0 is radius of curvature of flexible members. In Fig. 6 the graphs illustrating the above relationship when $r = 0.6R_0$ are given. When improper parameters are chosen, some undesirable force Q may considerably exceed the circular force. The parametric values providing for minimum Q value are most appropriate.

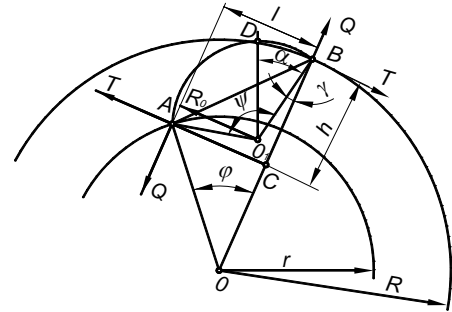

Fig.5 Design scheme of flexible arched member

Carrying capacity of the coupling is highly determined by bending strength of a flexible member. Bending moment of the section, the position of which depends on the angle α , is expressed in the following way

$$M_L = TR_0 \left\{ \cos \gamma (1 - \cos \alpha) - \sin \gamma \sin \alpha - g [\sin \gamma (1 - \cos \alpha) + \cos \gamma \sin \alpha] \right\} \quad (13)$$

The analysis of the expression (13) has shown that at any given coupling parameters, M_L assumes the largest value when $\alpha = \psi/2$.

To determine torsional coupling rigidity, a displacement in the direction of force T should be found

$$\delta_r = \frac{\partial \Pi}{\partial T} \quad (14)$$

where Π is potential bending energy.

By using (14) the following expression may be obtained for torsional coupling rigidity:

$$c_s = \frac{sEI_x R^2}{R_0^3 K} \quad (15)$$

where s is the number of flexible members in a coupling

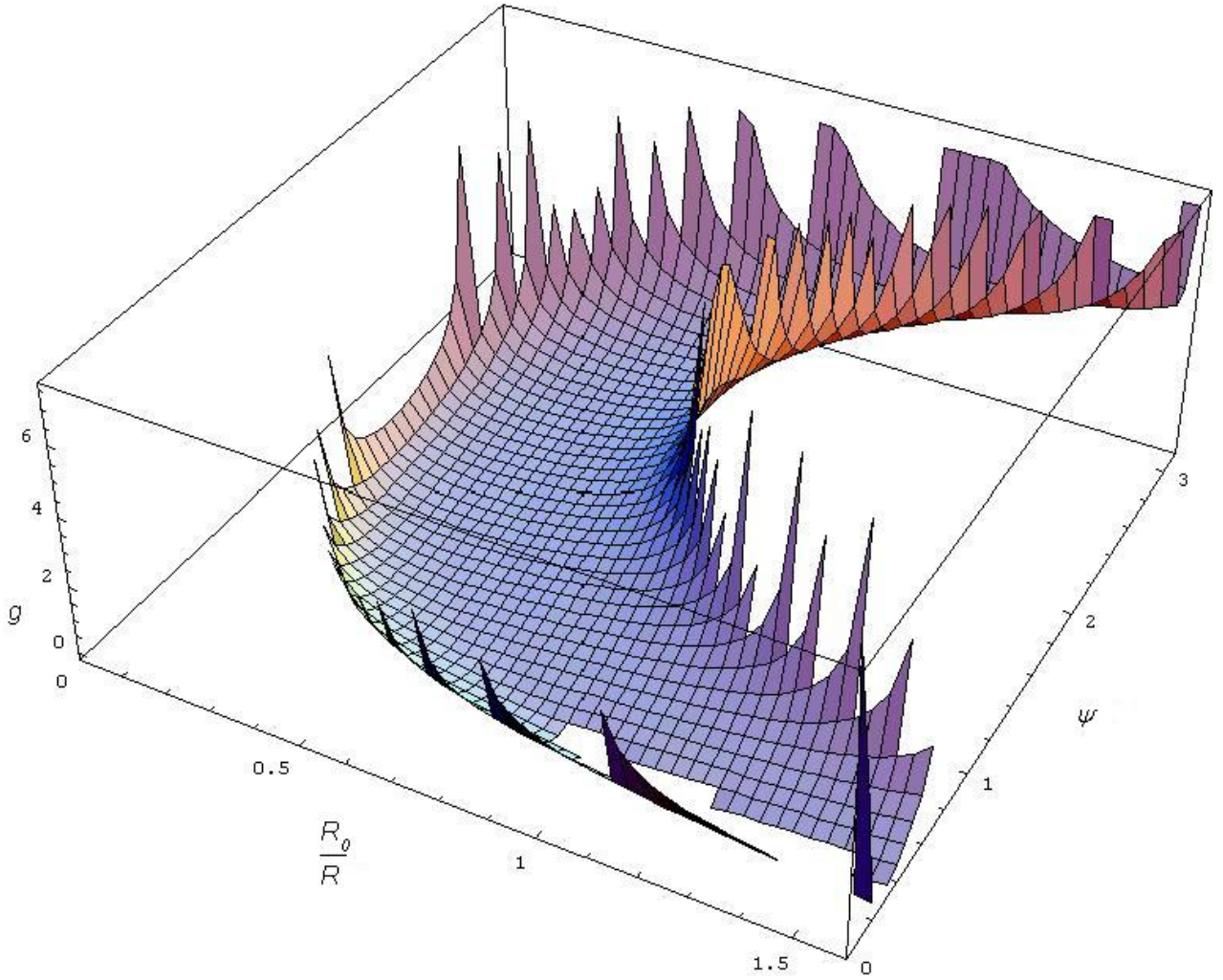

Fig. 6 Dependence of force ratio Q/T on the ratio of the radii R_0/R , when $r = 0.6R$; (Ψ – in accordance with Fig. 5)

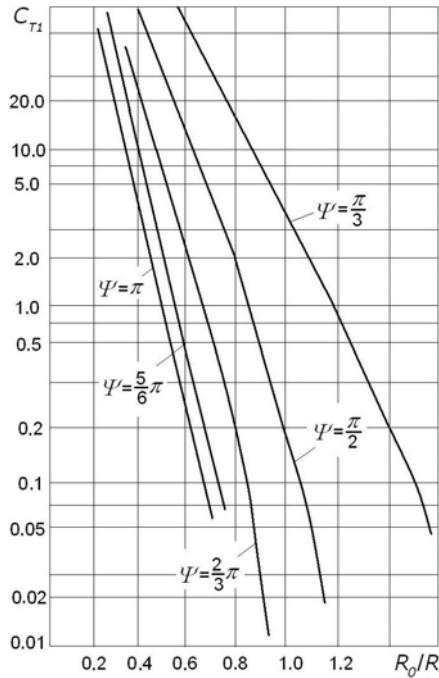

Fig. 7 Dependence of torsional rigidity on the ratio R_0/R , when $r = 0.6R$. C_{T1} is expressed in terms of $(R_0/R)^3/K$

$$K = a \cos^2 \gamma - 2b \sin \gamma \cos \gamma + c \sin^2 \gamma - 2g \left[(a - c) \sin \gamma \cos \gamma + b (\cos^2 \gamma - \sin^2 \gamma) \right] + g^2 \left[a \cos^2 \gamma + 2b \sin \gamma \cos \gamma + c \sin^2 \gamma \right]$$

$$a = \frac{3}{2} \Psi - 2 \sin \Psi + \frac{1}{2} \sin 2\Psi$$

$$b = 1 - \cos \Psi - \frac{1}{2} \sin \Psi$$

$$c = \frac{1}{2} \Psi - \frac{1}{4} \Psi$$

g corresponds to formula (12).

In Fig. 7 the graphs of the relationship (15) when $r = 0.6R$ are shown.

The graphs given in Figs. 6, 7 may be used in choosing the approximate coupling parameters.

4. Conclusions

1. The performance of mechanical system can be considerably improved by replacing a commonly used flexible coupling by a coupling with the rigidity abruptly changing when a transmitted torque is increased.

2. Rigidity and carrying capacity of couplings may be altered by changing the conditions of ring deforma-

tion. This may be achieved by using some additional supports or engagement with a reduced number of teeth.

3. Compensational ability of couplings is improved when several arc members are used instead of the flexible ring member.

References

1. **Gaudiler, L., Bocharol, S.** Adaptive active control of flexible structures subjected to ring body displacements.-*J. of Sound and Vibrations*, 2005, v.283, Issues 1-2, p.311-339.
2. **Loughlan, J., Ata, M.** The analysis of carbon fibre composite box beams subject to torsion with variable twist.-*Computer Analysis in Applied Mechanics and Engineering*, 1998, v.152, Issues 3-4, p.373-391.
3. **Kavlicoglu, B. and other.** High-torque magneto-rheological fluid clutch.-In: *Proc. of SPIE Conf. on Smart Materials and Structures*.-San Diego, March 2002, p.1-8.
4. **Timoshenko, S.** *Strength of Materials*.-Toronto, New York, London: D. van Nostrand Company, Inc., 1987. -384p.
5. **Ragulskis, K., Spruogis, B., Ragulskis, M.** Transformation of Rotational Motion by Inertia Couplings. *Monograph*.-Vilnius: Technika, 1999.-236p.

B. Spruogis, A. Jakštas

VIBROIZOLIACINĖS MOVOS DARBU KINTAMAIŠ ŽADINIMO REŽIMAIŠ

Re z i u m ė

Straipsnyje nagrinėjamos movos, kurių sukimo standumas ir leistinas perduodamas momentas kinta priklausomai nuo apkrovos. Analizuojamos movų charakteristikos atsižvelgiant į tampriojo elemento deformavimo sąlygas, taip pat ir kai naudojamos papildomos atramos. Nagrinėjamos dviejų tipų movos – su žiediniu ir su lanko formos tampriuoju elementu. Analizuojamas movų darbas

esant kintamoms apkrovoms. Movos skirtos mechaninių sistemų transmisijai.

B. Spruogis, A. Jakštas

VIBRATION ISOLATING COUPLINGS FOR OPERATION IN VARIOUS EXCITATION MOTIONS

S u m m a r y

The paper considers couplings of variable torsional rigidity and carrying capacity which varies depending on loading. Couplings are tested under varying deformation conditions of flexible element and when some additional supports are introduced. Two types of couplings having ring- and arch-shaped flexible elements are considered. Coupling performance under changing conditions is described. The couplings analysed are used in the systems of mechanical transmission.

Б. Спруогис, А. Якштас

ВИБРОИЗОЛЯЦИОННЫЕ МУФТЫ ДЛЯ ПЕРЕМЕННЫХ РЕЖИМОВ ВОЗБУЖДЕНИЯ

Р е з ю м е

В статье рассматриваются муфты, крутильная жесткость и несущая способность которых меняются в зависимости от нагрузки. Исследуются характеристики муфт с учетом условий деформации упругого элемента, в том числе и при применении дополнительных опор. Рассматриваются два типа муфт – с кольцообразными и дугообразными упругими элементами. Анализируется работа муфт при переменных нагрузках. Муфты предназначены для передачи механических систем.

Received April 12, 2005

DOI: 10.5755/j02.mech.14538