

Impact of contact rings in plate and blanket cylinders of printing section's drive on its dynamic accuracy

V.K Augustaitis*, N. Šešok**, I. Iljin***

*Vilnius Gediminas Technical University, Basanaviciaus 28, 03224 Vilnius, Lithuania, E-mail: pgkatedra@me.vtu.lt

**Vilnius Gediminas Technical University, Basanaviciaus 28, 03224 Vilnius, Lithuania, E-mail: pgses@me.vtu.lt

***Vilnius Gediminas Technical University, Basanaviciaus 28, 03224 Vilnius, Lithuania, E-mail: pgilj@me.vtu.lt

1. Introduction

A print (reproduction) of any image (original) may be produced in offset printing press as follows [1, 2]. A printing form with a prototype of the image to be reproduced is fixed to the plate cylinder of the printing press drive. On operation of the press, the prototype is moistened with printing ink, transferred to the surface of the plate cylinder fixed hereto and to the surface of the blanket of the blanket cylinder that rotates together with the said cylinder and from the blanket – onto the printing material (paper or similar) and thus the print is made. Rotation of plate and blanket cylinders is synchronized mechanically by connecting them with a gear.

In modern offset printing presses, seeking to reduce rotational vibrations of the plate and blanket cylinders as well as to increase rotation uniformity of the cylinders, the plate and blanket cylinders connected with gearwheels are in addition pressed against each other with 30 mm wide cylindrical steel contact rings, mounted at their edges. The said rings are pressed against each other with a force of about 12000-14000 N [1, 2]. So, the rotating cylinders are cohered both with the gearwheels and the contact rings.

One of application variants of the contact rings is shown in Fig. 1. It presents the scheme of a drive of the both-side printing section of the web offset printing press (the whole machine consists of printing and other sections that are rotated by the mutual engine via cardan shaft and gearwheels).

A section's drive consists of the blanket cylinders 1, 2 and plate cylinders 3, 4 that are connected with 5-8 gearwheels and rotate in bearings. The drive is rotated by the cardan shaft 11, connected to it with the conical gears 9, 10. Cylinders 1, 4 and 2, 3 are pressed against each other with contact rings 12. Paper tape (not shown in Fig. 1) is used for transfer of the prints from the blanket cylinders onto both sides of it; it moves between the rotating blanket cylinders 1 and 2; the contact rings of the said cylinders do not touch each other, because the distance between the axes of rotation of the cylinders is adjusted.

The object of the paper: to investigate the impact of contact rings upon intensity of rotational vibrations of the plate and blanket cylinders 1-4, following the scheme of the section's drive provided in Fig. 1 and applying the method of computer-aided analysis. The greatest attention should be paid to relative rotational vibrations between the cylinders, because the quality of prints directly depends on them.

The scheme provided in Fig. 1 is the one of a generalized character. It is applied to qualitative investigation of the impact of contact rings upon vibrations of the

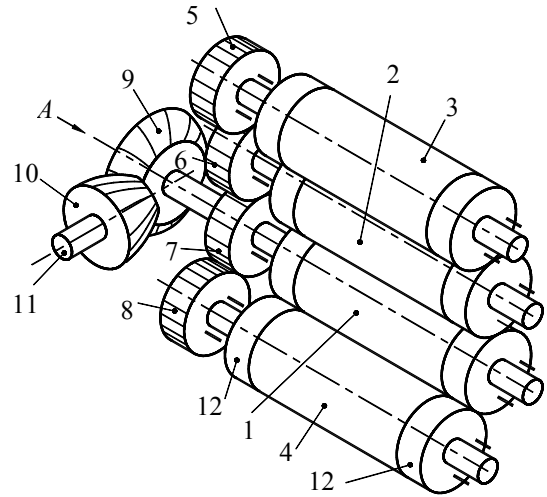

Fig. 1 The scheme of the printing section's drive under investigation

cylinders and does not pretend to be a precise adequate model of any printing section's drive.

2. Dynamical model development

For the investigation, a dynamic model (scheme of calculation) of the drive shown in Fig. 1 was developed. Cylinders and gearwheels that rotate in nondeforming bearings are considered as absolutely rigid bodies interconnected with links that are elastic to twists and have certain damping. In addition, it is accepted that the developed dynamic model is linear and the values identifying its elements (the parameters of the model) are constant (Fig. 2).

The elements of the model: I_1, \dots, I_4 are moments of inertia of the blanket cylinders 1, 2 and the plate cylinders 3, 4 (here and hereinafter all shown moments of inertia are calculated about rotation axes of the bodies), I_2 – contact rings steadily fixed to the cylinders, I_3 – blanket tissue that covers the blanket cylinders 1, 2; I_5, \dots, I_{10} are inertia moments of the gearwheels 5, ..., 10; $I_{11} = \infty$ – is inertia moment of the cardan shaft; c_c, r_c, c_r, r_r and c_k, r_k are coefficients of stiffness and damping, correspondingly, of the elements elastic to twists that connect the gearwheels 5, ..., 8 with the cylinders 1, ..., 4, the gearwheels 7, 9 and 10 with the cardan shaft 11; b_c, b_s, b_r, b_k are coefficients of damping of bearing units; c_τ, r_τ are coefficients of stiffness and damping, correspondingly, of the elastic element used for the simulation of reciprocal tangential shifts of the pressed contacts rings 12 (Fig. 2, b).

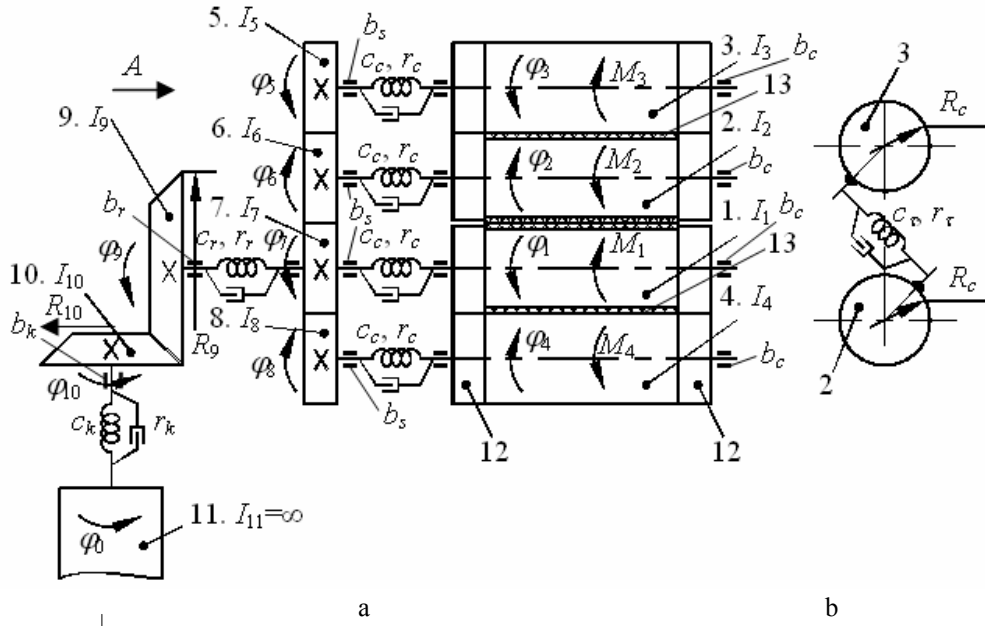

Fig. 2 Dynamical model of the printing section drive: a – general view; b – the scheme of simulation of tangential shifts between the contact rings pressed against each other

It is accepted that the following external excitation forces affect the drive under investigation in the period t :

- the moments of resistance M_1, \dots, M_4 that affect the cylinders $1, \dots, 4$; these moments are caused by variable resistance forces of the blanket 13 between the pressed against each other cylinders;
- kinematic excitation $\varphi_0 = \varphi_0(t)$ that simulates nonuniform motion of the cardan shaft;
- cyclic errors of gearwheel cohesion (their simulation is provided below).

The positions of all gears and cylinders $1, \dots, 10$ are identified using coordinates $\varphi_1, \dots, \varphi_{10}$; their positive directions of rotation (shown in Fig. 2) correspond to the directions of rotation of the shafts and cylinders on operation of the machine.

3. Formation of equations

The equations are formed according to the dynamic model provided in Fig. 2, using the Lagrange equations of the second type [3-5].

$$\frac{d}{dt} \left(\frac{\partial T}{\partial \dot{q}_i} \right) - \frac{\partial T}{\partial q_i} + \frac{\partial \Phi}{\partial q_i} + \frac{\partial \Pi}{\partial q_i} = Q_i \quad (i = 1, 2, \dots, n) \quad (1)$$

where T, Π, Φ are kinetic energy, potential energy and dissipative function of the system under discussion; q_i is the i -th generalized coordinate; Q_i is the generalized force acting according to the coordinate q_i (in the case under discussion, the forces Q_i do not include generalized forces caused by errors of gearwheels and nonuniform rotation of the cardan shaft).

The following generalized coordinates (so called principal coordinates) are chosen for the Eq. (1)

$$q_p = \varphi_1, \varphi_2, \varphi_3, \varphi_4, \varphi_7, \varphi_9 \quad (2)$$

The other coordinates $\varphi_5, \varphi_6, \varphi_8, \varphi_{10}$, shown in Fig. 2, are referred to as the auxiliary coordinates [4], because they are unambiguously expressed through the principal coordinates (2). These expressions, where cyclic errors of gearwheels cohesion are taken into account as well, are found as follows in accordance with [5].

The expression for the angle φ_{10} is found from the equations

$$\left. \begin{aligned} R_{10}\varphi_{10} &= R_9\varphi_9 + \Delta_{9,10} \\ \varphi_{10} &= i\varphi_9 + \alpha_{9,10} \end{aligned} \right\} \quad (3)$$

where $\Delta_{9,10}, \alpha_{9,10} = \Delta_{9,10}/R_{10}$ are cyclic linear and angular errors of gearwheels 9 and 10 cohesion, $i = R_9/R_{10}$.

The expressions for the angles $\varphi_5, \varphi_6, \varphi_8$ through the angle φ_7 are found using the scheme provided in Fig. 3, where R_k is base circles of the gearwheels (the same); δ_{ij} ($i, j = 5, 6, 7, 8$) are cyclic linear error of the i -th gear wheel in its cohesion with the j -th gearwheel, for example, $\delta_{6,5}$ is cyclic linear error of the 6-th gearwheel in its cohesion with the 5-th gearwheel, and so on.

According to Fig. 3, we find

$$\varphi_6 R_k = \varphi_7 R_k + \delta_{6,7} + \delta_{7,6} \quad (4)$$

$$\varphi_5 R_k = \varphi_6 R_k + \delta_{5,6} + \delta_{6,5} \quad (5)$$

$$\varphi_8 R_k = \varphi_7 R_k + \delta_{7,8} + \delta_{8,7} \quad (6)$$

After the transformation, we obtain the following final expressions

$$\varphi_5 = \varphi_7 + \alpha_{5,6} + \alpha_{6,5} + \alpha_{6,7} + \alpha_{7,6} = \varphi_7 + \Delta_{5,7} \quad (7)$$

$$\varphi_6 = \varphi_7 + \alpha_{6,7} + \alpha_{7,6} = \varphi_7 + \Delta_{6,7} \quad (8)$$

$$\varphi_8 = \varphi_7 + \alpha_{7,8} + \alpha_{8,7} = \varphi_7 + \Delta_{8,7} \quad (9)$$

where $\alpha_{5,6} = \delta_{5,6}/R_k$, ..., $\alpha_{8,7} = \delta_{8,7}/R_k$.

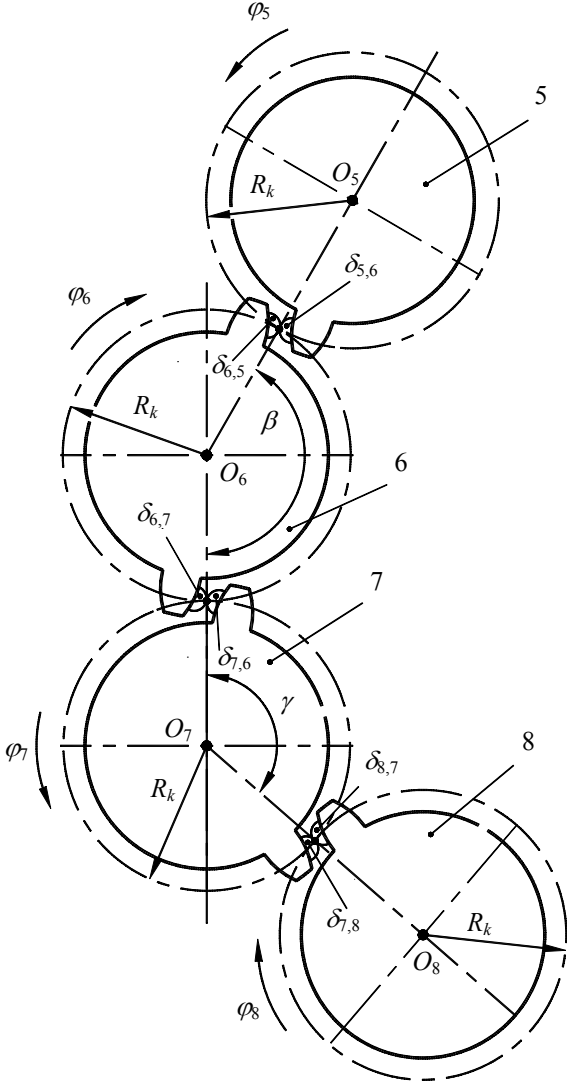

Fig. 3 Cohesion scheme of the gearwheels 5-8 (see Fig. 1 according to A)

The expressions of kinetic energy T , potential energy Π and dissipative function Φ from the Eqs. (1) are firstly formed with the auxiliary coordinates $\varphi_5, \varphi_6, \varphi_8, \varphi_{10}$ and their derivatives (see Fig. 2)

$$T = \frac{1}{2} \sum_{m=1}^{10} J_m \dot{\varphi}_m^2 \quad (10)$$

$$\begin{aligned} \Pi = \frac{1}{2} \{ & c_c [(\varphi_1 - \varphi_7)^2 + (\varphi_2 - \varphi_6)^2 + (\varphi_3 - \varphi_5)^2 + \\ & + (\varphi_4 - \varphi_8)^2] + c_r [(\varphi_2 - \varphi_3)^2 + (\varphi_1 - \varphi_4)^2] + \\ & + c_r (\varphi_9 - \varphi_7)^2 + c_k (\varphi_{10} - \varphi_0)^2 \} \end{aligned} \quad (11)$$

$$\begin{aligned} \Phi = \frac{1}{2} \{ & r_c [(\dot{\varphi}_1 - \dot{\varphi}_7)^2 + (\dot{\varphi}_2 - \dot{\varphi}_6)^2 + (\dot{\varphi}_3 - \dot{\varphi}_5)^2 + \\ & + (\dot{\varphi}_4 - \dot{\varphi}_8)^2] + r_r [(\dot{\varphi}_2 - \dot{\varphi}_3)^2 + (\dot{\varphi}_1 - \dot{\varphi}_4)^2] + \\ & + r_r (\dot{\varphi}_9 - \dot{\varphi}_7)^2 + r_k (\dot{\varphi}_{10} - \dot{\varphi}_0)^2 + \\ & + b_c (\dot{\varphi}_1 + \dot{\varphi}_2 + \dot{\varphi}_3 + \dot{\varphi}_4)^2 + b_s (\dot{\varphi}_5 + \dot{\varphi}_6 + 2\dot{\varphi}_7 + \dot{\varphi}_8)^2 + \\ & + b_r \dot{\varphi}_9 + b_k \dot{\varphi}_{10} \} \end{aligned} \quad (12)$$

After insertion of the auxiliary coordinates values and their derivatives, from (3), (7)-(9), into these equations, we find final values of the functions T , Π , Φ that include only principal coordinates (2), their derivatives, cyclic errors of the gearwheels and the angle of cardan shaft of rotation φ_0 with its derivative $\dot{\varphi}_0$.

From the scheme provided in Fig. 2, the following generalized forces included into the Eqs. (1) are found on the base of [3, 4]

$$\begin{aligned} Q_1 &= -M_1(t); \quad Q_2 = -M_2(t); \quad Q_3 = -M_3(t) \\ Q_4 &= -M_4(t); \quad Q_7 = Q_9 = 0 \end{aligned} \quad (13)$$

After differentiation of T , Π , Φ included into the Eqs. (1) according to the coordinates (2) and their derivatives according to time t and using the known values of the forces Q_i (13), we form six differential equations; each of them corresponds to one of the coordinates (2). If we remain only the members with the coordinates (2) and their derivatives according to time t in the left parts of the equations, the following system of equations is formed

$$[A] \ddot{q} + [B] \dot{q} + [C] q = \{F(t)\} \quad (14)$$

where $\{q\} = \{\varphi_1, \varphi_2, \varphi_3, \varphi_4, \varphi_7, \varphi_9\}^T$ is the vector of principal generalized coordinates; $[A]$, $[B]$, $[C]$ are the matrices of inertia, damping and stiffness; $\{F(t)\}$ is the vector of external exciting forces, consisting of the forces Q_i and the components depending on cyclic errors of gearwheels and the angle φ_0 of rotation of the cardan shaft and its derivatives according to time t .

The following expressions values of the matrices $[A]$, $[B]$, $[C]$ and the vector $\{F(t)\}$ are found

$$[A] = \text{diag}\{I_1, I_2, I_3, I_4, (I_5 + I_6 + I_7 + I_8), (I_9 + i^2 I_{10})\} \quad (15)$$

$$[B] = \begin{bmatrix} r_c + r_\tau + b_c + r_{1,2} + r_{1,4} & -r_{1,2} & 0 & -(r_\tau + r_{1,4}) & -r_c & 0 \\ -r_{1,2} & r_c + r_\tau + b_c + r_{1,2} + r_{2,3} & -(r_\tau + r_{2,3}) & 0 & -r_c & 0 \\ 0 & -(r_\tau + r_{2,3}) & r_c + r_\tau + b_c + r_{2,3} & 0 & -r_c & 0 \\ -(r_\tau + r_{1,4}) & 0 & 0 & r_c + r_\tau + b_c + r_{1,4} & -r_c & 0 \\ -r_c & -r_c & -r_c & -r_c & 4r_c + r_\tau + 5b_s & -r_r \\ 0 & 0 & 0 & 0 & -r_r & r_\tau + i^2 r_k + b_r + i^2 b_k \end{bmatrix} \quad (16)$$

$$[C] = \begin{bmatrix} c_c + c_\tau & 0 & 0 & -c_\tau & -c_c & 0 \\ 0 & c_c + c_\tau & -c_\tau & 0 & -c_c & 0 \\ 0 & -c_\tau & c_c + c_\tau & 0 & -c_c & 0 \\ -c_\tau & 0 & 0 & c_c + c_\tau & -c_c & 0 \\ -c_c & -c_c & -c_c & -c_c & 4c_c + c_\tau & -c_r \\ 0 & 0 & 0 & 0 & -c_r & c_\tau + i^2 c_k \end{bmatrix} \quad (17)$$

$$\{F(t)\} = \left\{ \begin{array}{l} -M_1(t) \\ -M_2(t) + r_c \Delta_{6,7} + c_c \Delta_{6,7} \\ -M_3(t) + r_c \Delta_{5,7} + c_c \Delta_{5,7} \\ -M_4(t) + r_c \Delta_{8,7} + c_c \Delta_{8,7} \\ -I_5 \Delta_{5,7} - I_6 \Delta_{6,7} - I_8 \Delta_{8,7} - (r_c + b_s) (\Delta_{5,7} + \Delta_{6,7} + \Delta_{8,7}) - c_c (\Delta_{5,7} + \Delta_{6,7} + \Delta_{8,7}) \\ -I_{10} i \alpha_{9,10} - b_k i \alpha_{9,10} - c_k i \alpha_{9,10} + c_k i \varphi_0 \end{array} \right\} \quad (18)$$

4. Investigation of the drive

Dynamical features of the drive of a printing section with the cylinders provided with contact rings (briefly – “cylinders with the rings”) or without them are examined herein on the base of the Eqs. (14). Using the set of softwares DDINCHAR [5] targeted for the investigation of dynamic features of machines, the amplitude-frequency responses of rotational vibrations of the plate and blanket cylinders were calculated and analyzed; a particular attention was paid to relative vibrations between cylinders and free vibrations of the drive.

The following values of the drive parameters used in the equations (14) were accepted. The transmission ratio $i = 2$. The moments of inertia (kg m^2): $I_1 = I_4 = 0.7$; $I_2 = I_3 = 1.4$; $I_5 = I_6 = I_8 = 0.05$; $I_7 = 0.07$; $I_9 = 0.14$; $I_{10} = 0.025$. The coefficients of stiffness (Nm/rad): $c_c = 1 \cdot 10^4$; $c_r = 8 \cdot 10^3$; $c_k = 2 \cdot 10^3$; $c_\tau = 4 \cdot 10^5$. The coefficients of damping (Nms/rad): $b_c = 10$; $b_k = b_r = b_s = 3$; $r_{1,2} = 8$; $r_{2,3} = 7$.

The values of the coefficients of stiffness and damping were found on the base of the references [6-9]. It was accepted [6,8] that linear tangential coefficient of stiffness of two rings pressed against each other $k_\tau = Q/e_\tau$; where Q is average area of the contact sur-

face of the rings pressed against each other; e_τ is the coefficient of contact tangential mobility, when the contact surface area is one unit of area (such as 1 mm^2 , 1 m^2 and so on). The coefficient of rotational stiffness of the rings pressed against each other $c_\tau = c_r = k_\tau / R^2$ (radius of rings).

In our case, $e_\tau = 1 \cdot 10^{-6} \text{ } \mu / (\text{Nm}^2) = 1 \cdot 10^{-12} \text{ m}^3/\text{N}$ [6, 8], $Q = 2 \cdot 10^{-5} \text{ m}^2$ (the force of compression of 30 mm wide rings equals to 14000 N), $R = 0.1 \text{ m}$, $k_\tau = 2 \cdot 10^7 \text{ N/m}$ and $c_\tau = 2 \cdot 10^5 \text{ Nm/rad}$ (for a couple of rings).

The impact of the rings upon natural vibrations of the cylinders was found as follows: by examining the roots of characteristic equation of the drive $\lambda_j = \varepsilon_j + i2\pi f_j$ ($j = 1, \dots, 6$; ε_j , f_j is real parts of the roots and frequencies of natural vibrations; $\lambda_n = \varepsilon_j - i2\pi f_j$ is neglected) as well as the shapes of vibrations that correspond to the frequencies f_j . The following features of natural vibrations were found (see Table 1 and Fig. 4 in addition).

1. In a drive with rings and without rings, four roots $\lambda_1, \dots, \lambda_4$ and the shapes of natural vibrations that correspond to the natural frequencies f_1, \dots, f_4 are practi-

cally the same (only λ_2 is different). In a drive with rings, the roots λ_5 , λ_6 and the shapes of natural vibrations that correspond to them are formed by contacts of the rings and these data have no practical importance for the problem under discussion, because natural frequencies f_5 and f_6 are high. In a drive without rings, the roots λ_5 , λ_6 and the shapes of natural vibrations that correspond to them are important.

2. The following parameters of the drive's dynamical model mostly impact natural frequencies f_j and the shapes of natural vibrations that correspond to them:

- the frequency $f_1 = 4.457$ Hz that is formed by the moments of inertia I_1, \dots, I_4 of the cylinders and coefficients of stiffness c_r and c_c ;
- the frequency $f_2 = 15.17$ and 12.73 Hz that is formed by the moments of inertia I_1, \dots, I_4 of the cylinders and coefficients of stiffness c_r and

c_c ;

- the frequency $f_3 = 22.82$ Hz that is formed by the coefficients of stiffness c_r and c_k and the moments of inertia I_9, I_{10} ;
- the frequency $f_4 = 61.85$ Hz that is formed by the coefficients of stiffness c_c, c_r and c_k and the moments of inertia I_5, \dots, I_8 ;
- in a drive without rings: the frequency $f_5 = 6.38$ Hz that is formed by the moments of inertia I_2, I_3 and coefficients of stiffness c_c of two elastic members connected to them and the frequency $f_6 = 15.52$ Hz that is formed by the moments of inertia I_1, I_4 and two remained coefficients of stiffness c_c .

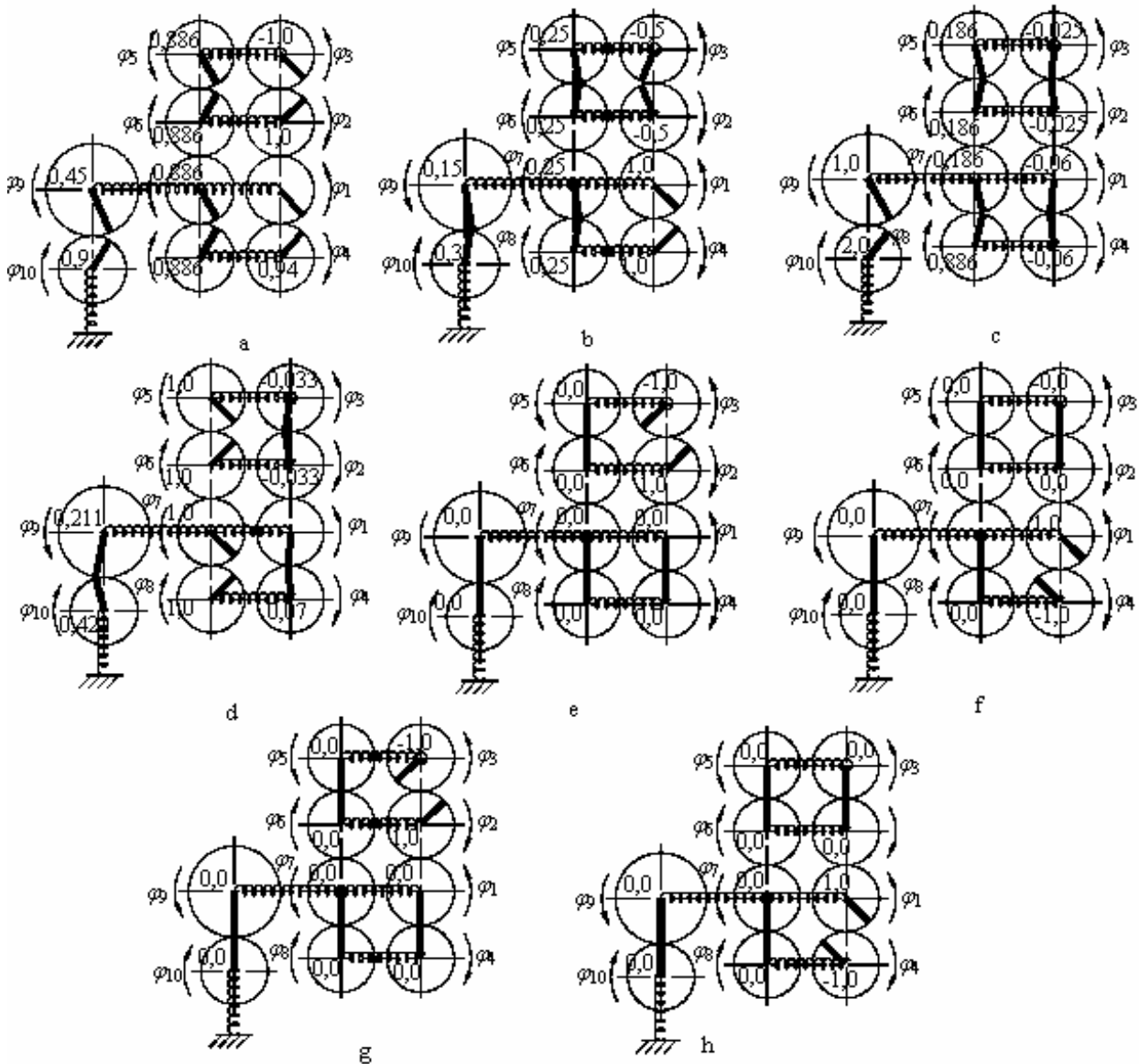

Fig. 4 Shapes of natural vibrations (when damping is neglected): a, ..., f – for a drive with contact rings; a, ..., d, g, h – without them

Table 1
Real parts ε_j of the roots $\lambda_j = \varepsilon_j \pm i2\pi f_j$ of characteristic equation of the drive and natural frequencies f_j (in brackets – the frequencies f_j , when damping is neglected)

Consecutive number j	Cylinders with rings		Cylinders without rings	
	$-\varepsilon_j, s^{-1}$	f_j, Hz	$-\varepsilon_j, s^{-1}$	f_j, Hz
1	6.57	4.457 (4.532)	6.57	4.457 (4.532)
2	40.93	15.17 (16.49)	47.8	12.73 (16.49)
3	198.3	22.82 (39.13)	198.3	22.82 (39.13)
4	266	61.85 (75.46)	266	61.85 (75.46)
5	4332	1302 (1473)	102,7	6.380 (13.45)
6	8664	1562 (2084)	29.65	15.52 (19.02)

3. The rings eliminate undesired relative vibrations of natural frequencies 6.38 Hz and 15.52 Hz (13.45 Hz and 19.02 Hz, if damping is neglected) between the plate and offset cylinders (Fig. 4). However, it may be seen from Fig. 4, b that undesirable relative vibrations of 15.17 Hz natural frequency (16.49 Hz, if damping is neglected) as well as forced resonance vibrations may appear between the blanket cylinders and the contact rings do not reduce such vibrations.

It may be stated that recently two electric drives are installed in many-engine double-side printing sections controlled by electronic shaft for the elimination of analogous vibrations [1, 2]. One of them rotates cylinders 2 and 3, the other – cylinders 1 and 4. There is no any mechanical link between the cylinders 1 and 2; intensity of vibrations between them is reduced in electrical way.

4. Natural vibrations (as well forced resonance vibrations) of the maximum intensity may appear in the vicinity of the frequencies f_1 and f_2 , because real parts $|\varepsilon_1|$ and $|\varepsilon_2|$ of the roots λ_1 and λ_2 that correspond to them are minimum.

The investigation on the forced vibrations was carried out in way of analysis of the amplitude-frequency

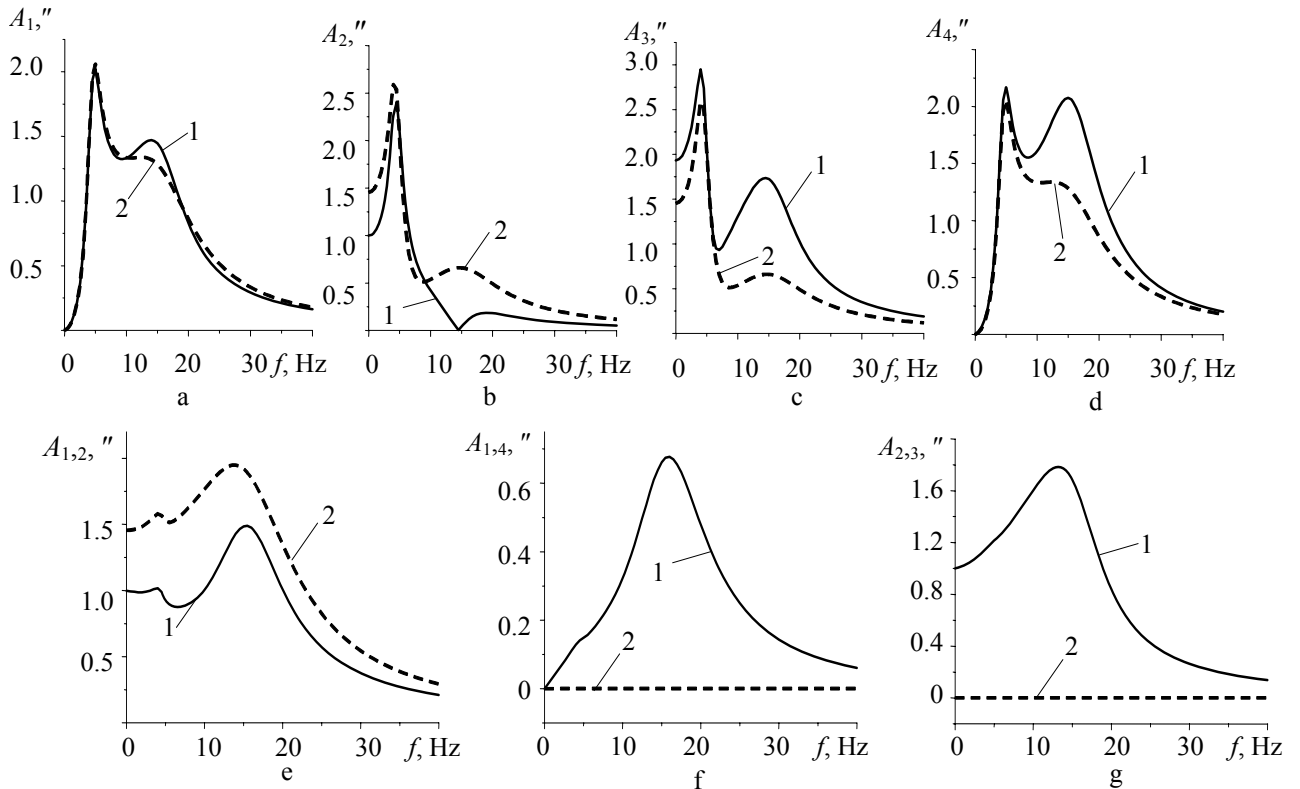

Fig. 5 Amplitude-frequency responses of vibrations of the cylinders caused by cyclic errors of the 6-th tooth-gear: a, b, c, d – according to the coordinates $\varphi_1, \varphi_2, \varphi_3$ and φ_4 ; e, f, g – according to the differences $\varphi_1 - \varphi_2, \varphi_1 - \varphi_4$ and $\varphi_2 - \varphi_3$ (" – angular second).

responses, calculated according to the coordinates $\varphi_1, \dots, \varphi_4$ for absolute vibrations of the cylinders and according to the differences $\varphi_1 - \varphi_2, \varphi_1 - \varphi_4, \varphi_2 - \varphi_3$ for relative vibrations between the cylinders. It was accepted that the drive is affected by the following harmonic excitation (see

Fig. 2 and 3):

- because of errors of the gearwheels 5 and 8

$$\alpha_{5,6} = \alpha_{8,7} = E_0 \sin vt \tag{19}$$

- because of errors of the gearwheels 6 and 7

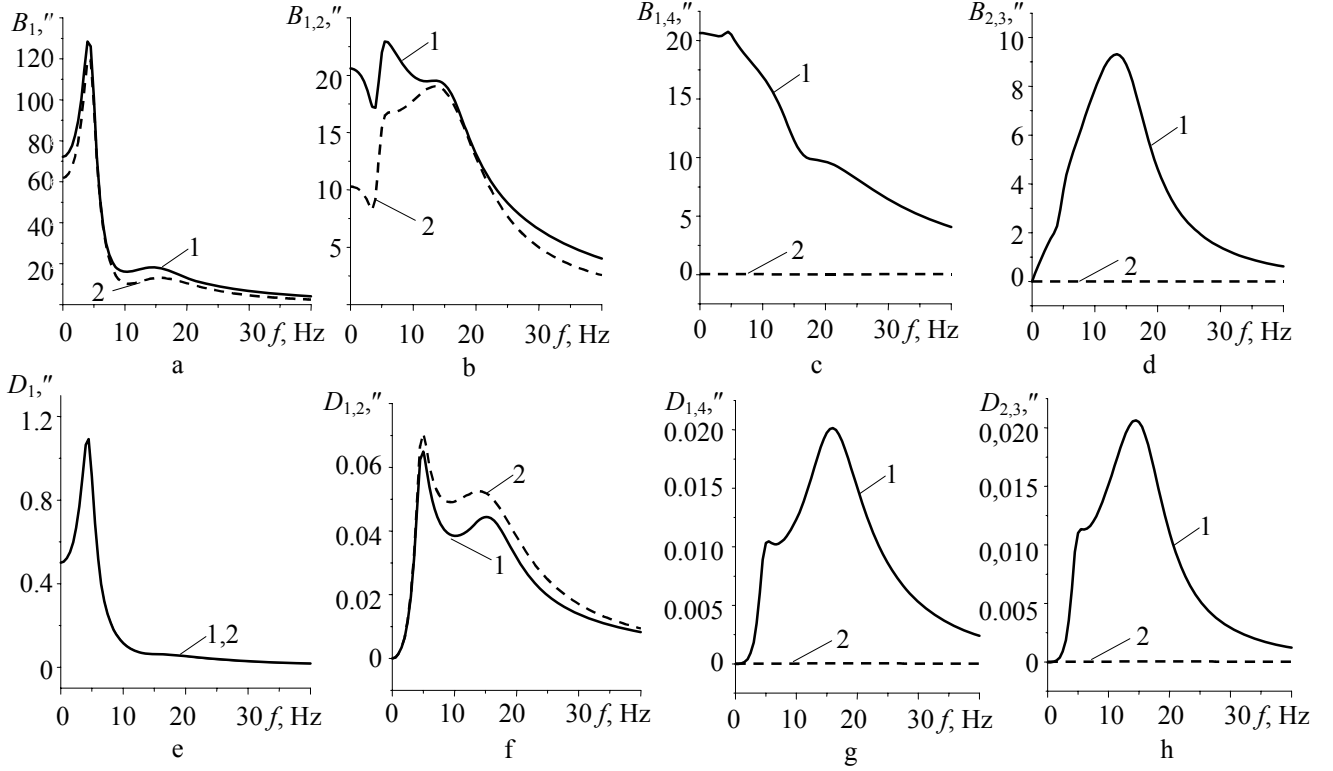

Fig. 6 Amplitude-frequency responses of vibrations of the cylinders caused by the moment of resistance M_1 (a, b, c, d) and variable rotation of the cardan shaft φ_0 (e, f, g, h): a, e – according to the coordinate φ_1 ; b, c, d and f, g, h – according to the differences $\varphi_1 - \varphi_2$, $\varphi_1 - \varphi_4$ or $\varphi_2 - \varphi_3$ (" – angular second)

$$\alpha_{6,5} + \alpha_{6,7} = E_0 [\sin \nu t + \sin(\nu t + \beta)] \quad (20)$$

$$\alpha_{7,6} + \alpha_{7,8} = E_0 [\sin \nu t + \sin(\nu t + \gamma)] \quad (21)$$

- because of the moments of resistance that impact the cylinders and variable rotation of the cardan shaft

$$M_k = M_0 \sin \nu t; (k = 1, \dots, 4); \varphi_0 = \Phi_0 \sin \nu t \quad (22)$$

It was accepted that $E_0 = 1''$, $\beta = 150^\circ$, $\gamma = 130^\circ$, $M_0 = 1 \text{ Nm}$, $\Phi_0 = 1''$, $\nu = 0 \div 500 \text{ Hz}$. Amplitude-frequency responses are calculated individually for each excitation.

Examples of the obtained amplitude-frequency responses are shown in Fig. 5 and 6. Here: 1, 2 – the amplitude-frequency responses for a drive without and with rings; A_i , B_i , D_i , A_{ij} , B_{ij} , D_{ij} are amplitudes of absolute and relative vibrations of the cylinders, respectively.

It may be stated that the use of contact rings impacts forced vibrations of the cylinders.

1. Relative vibrations $(\varphi_1 - \varphi_2)$, $(\varphi_1 - \varphi_4)$, $(\varphi_2 - \varphi_3)$ between the cylinders
 - a. Vibrations $(\varphi_1 - \varphi_2)$ caused by the errors of gearwheels 5, 6, 7, 8 increase and the vibrations $(\varphi_1 - \varphi_4)$ and $(\varphi_2 - \varphi_3)$ caused by the same reduce considerably.
 - b. Vibrations $(\varphi_1 - \varphi_2)$ caused by the errors $\alpha_{9,10}(t)$

of gearwheels 9 and 10 and the excitation $\varphi_0(t)$ of the cardan shaft increase and the vibrations $(\varphi_1 - \varphi_4)$ and $(\varphi_2 - \varphi_3)$ caused by the same reduce considerably.

- c. The moments of resistance M_1 and M_2 cause reduction of vibrations in any case; the moments of resistance M_3 and M_4 cause a considerable reduction of vibrations $(\varphi_1 - \varphi_4)$ and $(\varphi_2 - \varphi_3)$ and an increase of vibrations $(\varphi_1 - \varphi_2)$.
2. Absolute vibrations $\varphi_1, \dots, \varphi_4$ of the cylinders
 - a. Vibrations of the cylinders 1 and 2, caused by the errors of gearwheels 5, 6, 7, 8 increase or remain almost the same and vibrations of the cylinders 3 and 4 reduce
 - b. Vibrations caused by excitations $\alpha_{9,10}(t)$, $\varphi_0(t)$ and the moments of resistance M_1, \dots, M_4 remain almost invariable.

5. Conclusions

1. For the drive type of the printing press section under discussion, contact rings of the cylinders impact considerably relative and absolute rotational vibrations of the plate and blanket cylinders, however, this impact is unlike.

2. Contact rings reduce considerably relative vibrations between the plate and blanket cylinders in all cases of excitation and this feature is an important advantage of them; however, they almost always increase the relative vibrations between blanket cylinders, thus provid-

ing a negative impact upon the accuracy of the machine.

3. If contact rings are used, excitations, caused by the errors of gearwheels that connect the cylinders, in some cases reduce absolute rotational vibrations of the cylinders and in some

References

1. **Kipphan H.** Handbook of Print Media.- Berlin: Springer Verlag, Heidelberg, 2000.- 1708 p. (in Germanian).
2. **Shtolyakov, V.I., Fedoseyev, A.F., Zirnzak, L.F. et al.** Printing systems of Heidelberg company. Offset printing presses.- Moscow: MGUP Publishing-House, 1999.-216 p. (in Russian).
3. **Butenin, N.V.** Introduction to Analytical Mechanics.-Moscow: Nauka, 1971.-264p. (in Russian).
4. **Augustaitis, V.K.** Basics of Mechanical Vibrations.-Vilnius: Žiburys, 2000.-319p. (in Lithuanian).
5. **Augustaitis, V.-K.** The Analysis and Synthesis of Vibrations of Machines in Respect to a Drive of Metal-Cutting Machine.-Vilnius: Technika, Lithuania, 1994.-308p. (in Russian).
6. **Levina, Z.M., Reshetov, D.N.** Contact Stiffness of Machines.-Moscow: Mashinostroyeniye, 1971.-264p. (in Russian).
7. **Reshetov, D.N.** Details and Mechanisms of Metal-Cutting Machines.-Moscow: Mashinostroyeniye, 1972.-520p. (in Russian).
8. **Reshetov, D.N.** Operability and Reliability of Machine Details.- Moscow: Vysshaya shkola Publishing-House, 1974.-206p. (in Russian).
9. **Johnson, K.** Mechanics of Contact Interaction.-Moscow: Mir, 1989.-510p. (in Russian).

V.K Augustaitis, N. Šešok, I. Iljin

FORMINUOSE IR OFSETINIULOSE CILINDRUOSE
NAUDOJAMŲ KONTAKTINIŲ ŽIEDŲ ĮTAKA
SPAUSDINIMO SEKCIJOS PAVAROS DINAMINIAM
TIKSLUMUI

Reziumė

Šiuolaikinėse spaudos mašinų dvipusio spausdinimo sekcijų pavaroje ofsetinių ir formų cilindrų galuose pritvirtinti kontaktiniai plieniniai žiedai, kuriais šie besisukantys cilindrai suspaudžiami mašinos darbo metu. Nagrinėjama forminių ir ofsetinių cilindrų sukimosi virpesių amplitudinės dažninės charakteristikos, savieji dažniai bei savųjų virpesių formos. Gauta, kad bendru atveju žiedai mažina virpesių intensyvumą, tačiau jų įtaka nėra vienareikšmiškai teigiama: žiedai smarkiai sumažina santykinius virpesius tarp forminių ir ofsetinių cilindrų, tačiau padidina

virpesius tarp ofsetinių cilindrų, tarp kurių praeina atspaudas.

V.K Augustaitis, N. Šešok, I. Iljin

THE IMPACT OF CONTACT RINGS USED IN PLATE
AND BLANKET CYLINDERS OF THE PRINTING
SECTION'S DRIVE UPON ITS DYNAMIC
ACCURACY

Summary

In drives of printing section of modern web double-side printing presses, contact steel rings are attached at end of plate and blanket cylinders that press the cylinders against each other on their rotation. The amplitude-frequency response of rotational vibrations of the plate and blanket cylinders, their natural frequencies and shapes of natural vibrations are discussed upon herein. It is found that in a general case the rings reduce an intensity of the vibrations, however, their impact is not unambiguously positive: the rings reduce relative vibrations between the plate and blanket cylinders, however, they increase the vibrations between the blanket cylinders where a print passes.

В. К. Аугустайтис, Н. Шешок, И. Ильин

ВЛИЯНИЕ КОНТАКТНЫХ КОЛЕЦ,
ИСПОЛЪЗУЕМЫХ В ФОРМНЫХ И ОФСЕТНЫХ
ЦИЛИНДРАХ ПРИВОДА ПЕЧАТНОЙ СЕКЦИИ НА
ЕГО ДИНАМИЧЕСКУЮ ТОЧНОСТЬ

Резюме

В приводах секций двухсторонней печати современных печатных машин к концам офсетных и формных цилиндров прикреплены контактные стальные кольца, которыми эти вращающиеся цилиндры сжимаются между собой во время работы машины. Исследуются амплитудно-частотные характеристики, собственные частоты и формы собственных крутильных колебаний формных и офсетных цилиндров. Получено, что в общем случае кольца уменьшают интенсивность колебаний, однако их влияние не является однозначно положительным: кольца сильно уменьшают относительные колебания между формными и офсетными цилиндрами, однако увеличивают колебания между офсетными цилиндрами, между которыми проходят оттиски.

Received December 21, 2005

DOI: 10.5755/j02.mech.14756