

The influence of the arrangement scheme on balancing and mass dimension parameters of engines

E. Grigoryev, A. Vasilyev, K. Dolgov

Volgograd State Technical University, Lenin Avenue 28, 400131 Volgograd, Russia, E-mail: vasilyev@vstu.ru

1. Introduction

In piston internal combustion engines (ICE) resultant flywheel forces, which are transmitted to the engine frame and its support can act. They cause mechanical vibrations, reducing reliability and efficiency of the system, as well reduce comfort and working conditions, therefore the problem of balancing improvement is meant to be actual.

As it is known, complete or partial balancing can be achieved by the choice of the number of cylinders and the cylinder and crank arrangements. An alternative is applying special balancing mechanisms, which, however, complicate the construction and increase its mass. It must be mentioned, that the number of cylinders and the cylinder and crank arrangement also influence on the torque unevenness and revolution frequency, which can be increased in some cases. For decreasing them to the assumed value a flywheel of greater mass is installed. Therefore, arrangement scheme influences on mass dimension correlations of engines as well.

2. Mathematical model and results

As a rule a balancing analysis of engines is performed on the basis of the calculated scheme particular for each of them and the corresponding formulae [1], by computers. In connection with this it is advisable to use a generalized method based on uniform calculated scheme of the crank and connecting rod mechanism and a mathematical apparatus, by means of which one can investigate the balancing of any engine [2].

The unbalanced forces and moments, acting in the engine, have been defined on the basis of expressions for the calculation of resulting vertical and horizontal components, proceeding from the scheme of the crank, connecting rod mechanism and designations given in Fig. 1. The task becomes to the planar systems of forces problems. In the scheme the first and i -cylinders with the alteration angle of axes ε_1 and ε_i correspondingly are shown. For clockwise as a positive angular direction has been accepted. The cylinder position in the longitudinal direction is defined by the coordinate y_{1i} referred from the axis of the first cylinder. The distance from the middle of the first crank to the point of reducing 0 - l . The angle between cranks concerning the first crank is defined by the value φ_{1i} .

Proceeding from the taken scheme of calculation the expressions of resulting vertical and horizontal components of the inertia force moment of progressive actual masses (PAM) of the k -order become

$$M_{jk\theta} = m_n r \omega^2 A_k (A_{jk\theta} \cos k\varphi + B_{jk\theta} \sin k\varphi)$$

$$M_{jkz} = m_n r \omega^2 A_k (A_{jkz} \cos k\varphi + B_{jkz} \sin k\varphi)$$

where m_n is the mass of progressive actual elements; r is crank radius; ω is angular velocity of the crankshaft rotation; φ is the angle of action of the first crank concerning the first cylinder axis; $A_1 = 1$ where $k = 1$ and $A_2 = \lambda$ with $k = 2$, where λ is the ratio of the crank radius and the length of the connecting rod.

$$A_{jk\theta} = \sum_{i=1}^z (l - y_{1i}) \cos k(\varphi_{1i} + \varepsilon_1 - \varepsilon_i) \cos \varepsilon_i$$

$$B_{jk\theta} = -\sum_{i=1}^z (l - y_{1i}) \sin k(\varphi_{1i} + \varepsilon_1 - \varepsilon_i) \cos \varepsilon_i$$

$$A_{jkz} = \sum_{i=1}^z (l - y_{1i}) \cos k(\varphi_{1i} + \varepsilon_1 - \varepsilon_i) \sin \varepsilon_i$$

$$B_{jkz} = -\sum_{i=1}^z (l - y_{1i}) \sin k(\varphi_{1i} + \varepsilon_1 - \varepsilon_i) \sin \varepsilon_i$$

where z is the number of cylinders.

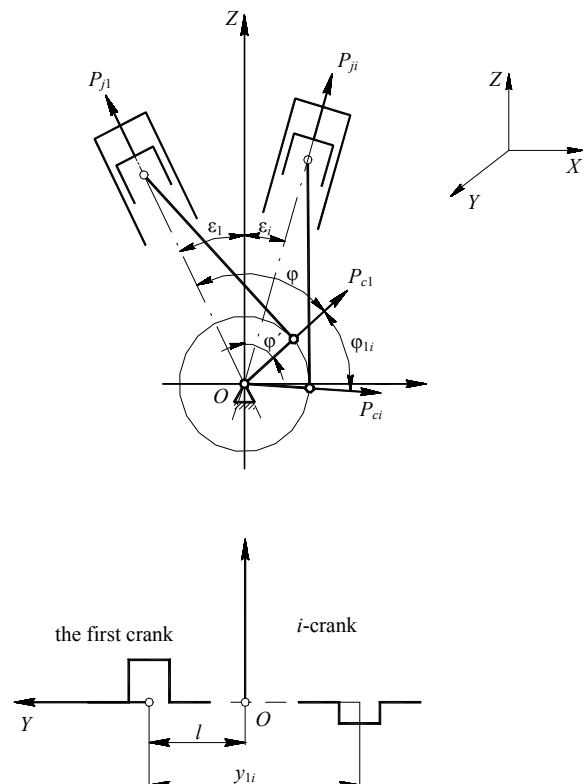

Fig. 1 Generalized calculated scheme of the crank and connecting rod mechanism

Vectorial resultants of the moments

$$M_{jk} = \sqrt{M_{jka}^2 + M_{jkb}^2}$$

Likewise vertical and horizontal components of the resultant flywheel forces the revolving and PAM of the first and second orders as well as the moments from the centrifugal inertia forces are calculated.

The given method of balancing calculation allows to set various arrangements of the crank and connecting rod mechanism, that is to carry on a great variety of investigations and analytically to define the unbalanced forces and the moments for them. Besides, that it is realized easily enough in the form of algorithm and computer programme.

Let us consider the influence of cylinder number and the crank and connecting rod mechanism schemes on the balancing indices of six and eight cylinder engines. The conducted computer analysis of balancing has been carried out with the angular change limit of vee cylinders γ (Fig. 2) from 0^0 to 180^0 and the step $\Delta\gamma = 10^0$.

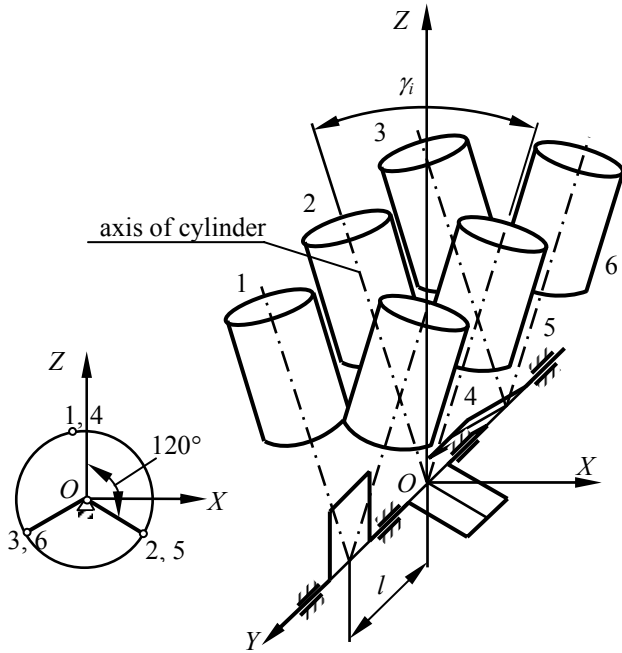

Fig. 2 The family of the six cylinder engines with various angles of the vee cylinders

The calculation algorithm (Fig. 3) provides the introduction of initial parameters of the crank and connecting rod mechanism scheme: the number of cylinders, their angular vee and in line arrangement, as well as the angles between cranks. Afterwards the calculation of unbalanced force factors for a particular arrangement is carried out.

The angle between the plane of moment action from centrifugal inertia forces and the plane of the first crank φ_0 , is also defined since it is necessary for correct arranging of counterweights, balancing the moment of centrifugal inertia forces.

Six Cylinder Engines. With $\gamma = 0^0$ – an in line engine with the cranks, arranged with mirror reflection at the angle of 120^0 . Therewith a complete balancing is provided under uniform alteration of flashes.

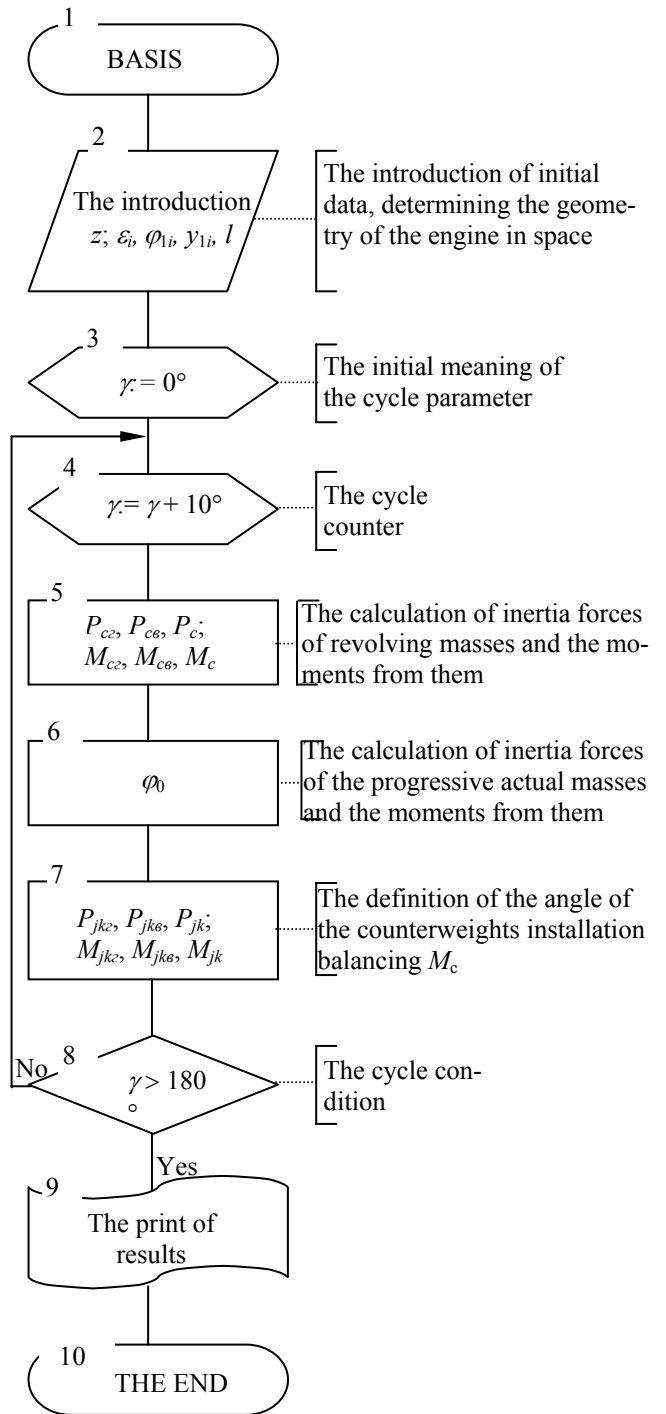

Fig. 3 The algorithm of calculating nominal balancing various crank and connecting rod schemes

The arrangements with $\gamma = 10-180^0$ have a three throw shaft with cranks, arranged at the angle of 120^0 (Fig. 2). Two connecting rods are joined to each journal. Here the moments from inertia forces revolving and the progressive actual masses of the first and second orders are not balanced. Their amplitude values have been defined

$$M_{c\alpha}^A = \sqrt{A_{c\alpha}^2 + B_{c\alpha}^2} m_r \omega^2 r a ; M_{c\beta}^A = \sqrt{A_{c\beta}^2 + B_{c\beta}^2} m_r \omega^2 r a$$

$$M_{jka}^A = \sqrt{A_{jka}^2 + B_{jka}^2} m_n \omega^2 r a$$

$$M_{jkb}^A = \sqrt{A_{jkb}^2 + B_{jkb}^2} m_n \omega^2 r a$$

where m_r is the mass of revolving elements; a is the distance between the midpoints of adjacent cranks.

They can be presented in dimensionless form

$$\begin{aligned}\bar{M}_{c\theta}^A &= M_{c\theta}^A / m_r \omega^2 r a; \quad \bar{M}_{c\epsilon}^A = M_{c\epsilon}^A / m_r \omega^2 r a \\ \bar{M}_{j_{k\theta}}^A &= M_{j_{k\theta}}^A / m_n \omega^2 r a; \quad \bar{M}_{j_{k\epsilon}}^A = M_{j_{k\epsilon}}^A / m_n \omega^2 r a\end{aligned}$$

In Fig. 4 you can see the dependences of amplitude expressions of immeasurable values of the unbalanced moments on the angle of vee cylinders, which provides the convenience of comparison of various crank schemes. With $\gamma=90^\circ$ the vertical moment component of inertia forces of the progressive actual masses of the second order has been balanced. In the scheme with $\gamma=180^\circ$ only M_c and $M_{j_{1\epsilon}}$ have not been balanced.

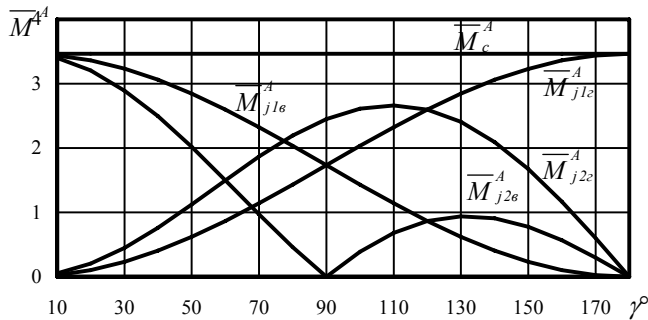

Fig. 4 The dependence of amplitude expressions of dimensionless values of unbalanced moments, acting in the six cylinder family, on vee cylinder angle

Eight Cylinder Engines. With $\gamma=0^\circ$ – an in line engine. Four middle and four last cranks are situated in two mutually perpendicular planes. Due to their mirror reflection arrangement a complete balancing is provided at the uniform alteration of flashes.

The schemes with $\gamma=10-180^\circ$ have a four crank cross-shaped crankshaft. The moments from the inertia forces revolving and the progressive actual masses of the first order (Fig. 5) are unbalanced. With $\gamma=180^\circ$ the vertical component of the moment of inertia forces of the progressive actual masses of the first order is balanced.

As far as eight cylinder arrangements with a flat crankshaft are known not to have a balanced inertia force of the PAM the second order, its balancing comes to complication of the construction. That is why such engines did not find any use.

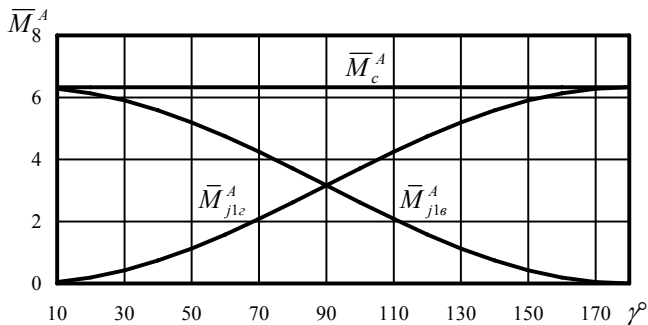

Fig. 5 The dependence of amplitude expressions of dimensionless values of unbalanced moments, acting in the eight cylinder family, on vee cylinder angle

The comparison of balancing six and eight cylin-

der engines permits to establish the character of function dependences of unbalanced moments on the angle of vee cylinders. So, the horizontal and vertical components of inertia forces of the PAM of the first and second order and their resultants depend on action angle of the crankshaft, and only in the schemes with $\gamma=90^\circ$ vector resultant of the moment of inertia forces of the PAM of the first order M_{j_1} does not depend on action angle of the crankshaft and that is why it can be balanced as well as M_c by installing counterweights on the continuation of its last cheeks.

On increasing the number of cylinders z (till six and eight) the balancing of V-shaped engines becomes better and with $z=8$ it turns out to be more favourable owing to balancing inertia forces of the progressive actual masses of the second order; therewith in line engines with even z they become completely balanced due to the principle of mirror reflection action. However, designing the in line constructions with a greater number of cylinders gives unfavourable mass dimension correlations (an increased length and a small breadth), as a result of which the block and the crankcase have low rigidity. The above mentioned drawback can be removed, if to apply a V-shaped scheme, allowing to reduce overall length, weight and consequently the engine cost.

The application of intermediate arrangements with the angle of vee cylinders $\gamma=10^\circ$ and 20° is very perspective at present, since the mentioned schemes combine the pluses of in line and V-shaped constructions. From the first ones they have positive data on balancing and from the second ones – a greater block rigidity.

It is obvious, that side by side with balancing the mass dimension parameters of the construction also depend on γ . Power, rotation frequency, cylinder diameter, crankshaft geometry are accepted to be permanent.

Let us make the analysis of the influence of vee cylinder angle γ on mass dimension parameters of six cylinder series. It is based on the definition of common engine mass including: the mass of its main part (remains constant); the flywheel mass, the counterweights, drive mechanisms, etc, which are calculated for each arrangement in accordance with the acting unbalanced force factors, the unevenness of flash alteration and are added to the mass of the main part of the power unit [3, 4, 5].

When calculating the masses of the main engine parts (the arrangements with $\gamma=0^\circ$ and 90°) the masses of counterweights for unloading the base bearings have not been considered. In the scheme with $\gamma=0^\circ$ this has been done for the sake of getting minimal mass of the crankshaft, and the arrangement with $\gamma=90^\circ$ has a short crankshaft and sufficient rigidity, capable to resist torsional vibrations.

Let us give full details to the definition of the mass of the engine main part. There is a great number of methods, allowing to evaluate the proposed engine mass [3, 4, 5] in the process of designing. All of them are based on statistical investigations of real constructions.

In the given work the method of synthesis of the crankshaft and connecting rod mechanism is used, its dimensions together with the statistical correlations between particular sizes of the base parts permitting to evaluate conditional size of the engine V_{en} [4]. The latter is mass ratio of the main engine part $M_{en.main}$ and its spatial density

M_v , permanent for a certain class of engines. This allows to determine the main part mass on the well known overall dimensions

$$M_{en.main} = M_v V_{en.}$$

Thus, the definition of the mass brings to the task of volume evaluation in limited base dimensions and to statistical estimation of volume density of the engine construction.

The flywheel masses have been defined according to a standart calculation method of inertia moments, main dimensions and a maximum circumferential velocity. It should be noted, that the flywheel masses have been calculated under the identical coefficient values of the unbalancing stroke δ , that is the adduction of all investigated arrangement schemes to all equal conditions have been carried out.

The masses of the counterweights for balancing M_c and M_{j1} (for example in the arrangement with $\gamma = 90^\circ$) have been determined from the condition of moments, being created by the counterweights, and the sums of resultant of the moments M_c and M_{j1} , revolving in one plane. In connection with this the mass of each counterweight is being calculated in the following way

$$\begin{aligned} M_c + M_{j1} &= m_{c.w} \rho_{c.w} \omega^2 b \\ 1.732 m_n r \omega^2 a + 1.732 m_r \omega^2 a &= m_{c.w} \rho_{c.w} \omega^2 b \\ 1.732 r \omega^2 a (m_r + m_n) &= m_{c.w} \rho_{c.w} \omega^2 b \end{aligned}$$

whence

$$m_{c.w} = (1.732 r a / \rho_{c.w} b) (m_r + m_n)$$

where $m_{c.w}$ is the mass of the counterweight, kg; $\rho_{c.w}$ is the distance from the centre of the counterweight masses to the axis of the crankshaft, m; b is the distance between the centres of the counterweight masses, m; a is the distance between the centres of connecting rod journals, m.

Balancing M_{j2} has not been considered, since this requires the installation of additional shafts (Lanchesters mechanism), which brings undesirable mass increase and dimensions of the construction.

As a result the dependences diagrams of general engine mass $\bar{m}_{en.gen}$ and its overall dimensions (\bar{L} is length, \bar{B} is breadth, \bar{H} is height) on the vee cylinder angle, have been obtained and presented in a dimensionless form in Fig. 6 and 7, with mass and length values of the in line arrangement being 1. In Fig. 6 the periods of increasing and decreasing of mass values of the investigated family can be observed. For example, the decreasing of the given function is observed for the schemes with the vee cylinder angle of 20° ; 110° ; 120° , this being accounted for a greater alteration evenness of flashes and an evenness of engine stroke. As it is known, with $\gamma = 0^\circ$, an even alteration of flashes is provided in 120° , but the given scheme has the greatest mass value. Due to great length of the in line construction.

The dependences presented in Fig. 4 and 6 allow to choose such arrangement schemes, which have a satisfactory balancing and acceptable mass values (e.g., 10° ; 90° ; 120°). Acceptability of size indices is determined to a

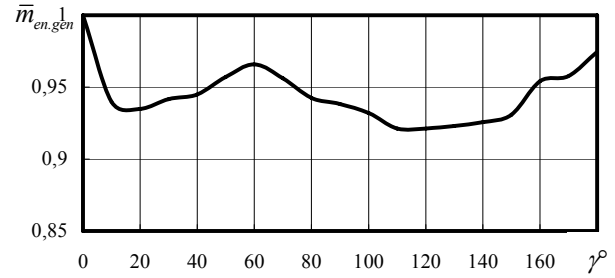

Fig. 6 Dependence of general engine mass on the vee cylinder angle

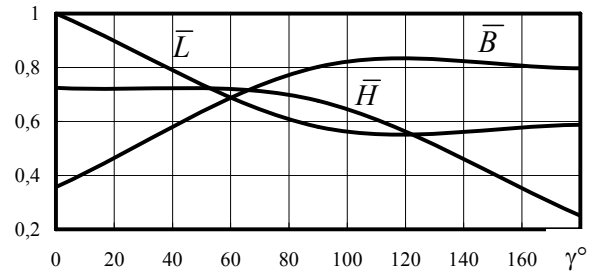

Fig. 7 Dependence of mass dimensions of the engine on the vee cylinder angle

considerable degree by the requirements to the engine arrangement in the motor block. So, an in line arrangement is applied in the case, when there are some limitations to breadth, but there is a possibility to arrange the engine according to height and length. If there is no such possibility, the V-shaped and opposite schemes are used.

One should mention the arrangement, with the vee angle $\gamma = 180^\circ$, having good balancing criteria, but with the chosen construction of the crankshaft it has got a maximum unevenness of flash alteration and, as a consequence, a great unevenness of the stroke, which brings to increasing of the general engine mass. On one hand of unbalanced force factors influence on the general engine mass: the higher are they, the greater is the mass of counterweights, necessary for their balancing, and on the other hand unevenness of the torque brings to increasing the flywheel mass.

3. Conclusions

The obtained indices of balancing, mass and overall dimensions can be applied when calculating engine vibrations with various arrangement schemes.

The accomplished investigation allows to choose the vee cylinders of engines according with their nominal balancing, mass dimension indices and evenness of flash alteration.

On the bases of generalized method of balancing calculation and mass dimension indices of engine and its programmed provision a universal method, permitting to carry out such investigations of various families has been created.

References

1. Popik K.G. Dynamics of Auto and Tractor Engines. -Moscow: Vyshaja Schola, 1970.-328p. (in Russian).
2. Grigoryev E. A. Periodic and Casual Forces Working

in the Piston Engine.-Moscow: Machino Building, 2002. -272p. (in Russian).

3. **Pogodin S.I., Koslov S.I.** The way of evaluating overall dimensions and mass of tractor engines in their designing.-Engine Building, 1986, No10, p.18-19 (in Russian).

4. **Ruderman I.L.** Empirical dependence of engine mass on its main parameters.-Engine Building, 1982, No6.-14p. (in Russian).

5. **Ruderman I.L.** The forecasting of the optimal parameters of the tractor diesel.-Engine Building, 1984, No2, p.5-10 (in Russian).

E. Grigoryev, A. Vasilyev, K. Dolgov

VARIKLIŲ IŠDĖSTYMO SCHEMOS ĮTAKA BALANSAVIMO BEI MASĖS IR MATMENŲ RODIKLIAMS

Re z i u m ė

Straipsnyje įvertinama cilindrų ir sliejikų skaičiaus išdėstymo įtaka balansavimo ir masės bei matmenų rodikliams. Atliktas dviejų grupių variklių subalansavimo įtakos tyrimas. Kiekvienam varikliui įtakos turinčių pagrindinių jėgos faktorių kompiuterinė analizė atlikta taikant apibendrintą nominaliojo balansavimo metodą. Meto- das remiasi skriejiko ir švaistiklio mechanizmo apibendrin- ta skaičiavimo schema ir bendromis matematinėmis pri- klausomybėmis ir tinka kiekvieno variklio balansavimui tirti.

E. Grigoryev, A. Vasilyev, K. Dolgov

THE INFLUENCE OF THE ARRANGEMENT SCHEME ON BALANCING AND MASS DIMENSION PARAMETERS OF ENGINES

S u m m a r y

The influence of the number of cylinders and the scheme of crank mechanism on the parameters of balancing, mass and size is evaluated in this article. The study of balancing of two sets of engines was fulfilled. Computer analysis of the main load – carrying factors present in each of the engines, was performed, using generalized method of calculation of nominal balancing. The idea of this method is the creation of unified computation scheme of crank mechanism and unified mathematical apparatus, by means of which it is possible to research balancing of any engine.

Е. Григорьев, А. Васильев, К. Долгов

ВЛИЯНИЕ КОМПОНОВОЧНОЙ СХЕМЫ НА УРАВНОВЕШЕННОСТЬ И МАССОГАБАРИТНЫЕ ПОКАЗАТЕЛИ ДВИГАТЕЛЕЙ

Р е з ю м е

В статье оценивается влияние числа и расположения цилиндров и кривошипов на уравновешенность и массогабаритные показатели двигателей. Проведено исследование уравновешенности двух семейств двигателей. Компьютерный анализ основных силовых факторов, действующих в каждом двигателе, был выполнен, используя обобщенный метод расчета номинальной уравновешенности. Суть метода состоит в создании обобщенной расчетной схемы кривошипно-шатунного механизма и единого математического аппарата, посредством чего возможно исследование уравновешенности любого двигателя.

Received December 22, 2005

DOI: 10.5755/j02.mech.14767