

Knowledge-based method for cavity number definition in injection mold design

Ž. Rutkauskas*, A. Bargelis**, G. Linß***

*Kaunas University of Technology, Kestučio str. 27, 44025 Kaunas, Lithuania, E-mail: zydrunas.rutkauskas@stud.ktu.lt

**Kaunas University of Technology, Kestučio str. 27, 44025 Kaunas, Lithuania, E-mail: algirdas.bargelis@ktu.lt

***Ilmenau Technical University, P.O. Box 10 05 65, Ilmenau, Germany, E-mail: Gerhard.linss@tu-ilmenau.de

1. Introduction

21st century often is named as a knowledge society. Knowledge acquirement in manufacturing science plays very important role seeking better productivity and competitive ability. Plastic is one of the most versatile materials in the modern manufacturing environment and is widely used in many products design. The injection molding process is the most common molding process for making plastic parts. The engineering tasks involved in injection molding are the design of part geometry, machining and polishing of mold cavities / core surfaces and cooling lines, mold assembly and test. The approach Design for X (DFX) widely is used in design of plastic parts and their injection molds for achieving minimal manufacturing cost and suitable quality. Concurrently this procedure involves extensive heuristic knowledge about the structure and functions of the components of the mold. It is the reason for knowledge-based system (KBS) or Expert System (ES) application [1]. These systems should support the decision maker in handling poorly structured decision problems of mold design. Conventional, nonconventional and combinative methods developing KBS and ES can be used. The application of both mentioned intelligent systems gains an advantage in the following cases:

- organization seeks to decrease the volume of routine employees' jobs;
- company often turns products;
- organization strives to increase the skills of young designers and retraining of employees.

This paper presents the ES structure of injection mold design and describes the knowledge-based method for the definition of a cavity number in mold design. The research provides a mold designer with an interactive computer-aided design (CAD) system the appropriate knowledge, rules and facts of injection mold design. The development is tested on a plastic part with five different production volumes.

2. Relative research

Common manufacture methods of plastic parts [2] are presented in Table 1. Mainstream of plastic parts manufacturing falls on injection molding that takes approx 75-85% of whole production volume. Plastic parts have some advantages as follows: they are long-lived, their geometrical form complexity does not influence the manufacturing process and cost. On the other hand, the relation between material properties, dimensions, and surfaces quality of a plastic part, and mold optimal design demands these advantages.

Table 1
Manufacturing methods of plastic parts

Manufacturing method	Application	Examples
Injection molding	Mass production of 3D parts	Various consumer goods, gearwheels, medicine techniques and so on
Hot stamping	Prototypes, low volume production of 2- 2,5D micro-structure parts	Various 2-2.5 D plastic parts as holders, grates, CD ROM prototypes, holograms and so on
Vacuum molds	Prototyping	Housings, reservoirs, holders, levers and so on

These parts have also drawbacks: high manufacturing cost and time of mold design and production, appropriate engineering knowledge and experience implementing them are reasonable only at large production volumes (not less than 5000-8000 pieces per year). No exchanges of plastic part design can be done when the mold is made. When geometrical form and dimensions of the part are changed, substituting of mold design and manufacturing is required. All mentioned factors, therefore, have to be evaluated and considered before mold design.

Numerous publications deal with the peculiarities of mold design applying conventional and artificial intelligence methods. They include various plastic materials, molding machines and methods, part geometrical form, dimensions and size. An interactive knowledge-based CAD system for mold design in injection molding processes [3] presents a practical prototype of artificial intelligence design method in molding manufacture. It attempts to tackle the problem in a practical and integrative way, unlike the stand-alone and mathematical programs, which have been developed in the past to solve only a part of the problem. Total quantitative and structured approach is not feasible in dealing with the complex and multirelated design problems generally involved in mold design. In this development the computational module, the knowledge-based module and the graphic module for generating mold features are integrated within an interactive CAD-based framework. Mold designers through interactive programs can access the knowledge base of the proposed system. The approach adopted both speeds up the design process and facilitates design standardization that in turn increases the speed of mold manufacture. Unfortunately, the described system has no artificial intelligence methods for

the definition of cavity number and the components of feed system, cooling system and ejection system. These tasks have been solved using standard or typical decisions which optimal selection demands high skills of designer.

The problems of molding microparts and parts with thin wall features are considered in source [4] as follows:

- injection molding of microcomponents easy to apply in mass production;
- injection molding of components with two microstructured sides;
- development of micropowder injection molding for microstructured metal and ceramic components made of carbonyl-iron 316 L, Al₂O₃ or material ZrO₂;
- reduction of mold manufacturing cycle times.

The distribution of manufacturing cost and quality are emphasized in source [5], when feed system of injection mold has been heated. The time of plastic part manufacturing cycle was decreased and feeding marks on the parts were removed. The systematization of plastic parts molding errors [6, 7] is made and the methods how to manage the errors of plastic parts design and molding procedures are proposed. The methods, consequently, how to remove errors and defects are foreseen. This development can increase the competitiveness of plastic parts manufacturing organization due to lower cost and better quality.

Specialized software Moldflow [8] is applied for the solution of filling mold problem in accordance with these factors: inside mold pressure, temperature and material. High accuracy of programmed and experimental results during software Moldflow testing and validation was outlined.

High-tech molding technologies [9] present novelties in plastic parts manufacturing processes. There co-injection (sandwich) molding, multicomponent injection molding, microinjection molding, gas-assisted injection molding and water injection molding are described. In order to survive in a hostile and competitive world, organizations need to do two things – to adapt and change the products and services, which they offer, and to adapt and change the ways in which they produce these. These two concepts are termed “product innovation” and “process innovation”. It is clear that today’s environment is rich in opportunities for technological change. Instead, much depends on how well companies manage the overall process of technological change – how they recognize the important signals about threats and opportunities in their market place, how they interpret those signals and create a viable strategy, how they acquire the technological resources and knowledge that they need and how they are able to learn from the experience.

Institut Kunststoff Verarbeitung (Aachen) during latter years developed plastic molding machines, molds and molding technologies for microparts and thermoplasts manufacture [10]. The mold feed system with minimal molten plastic material doze were created and investigated. This development reduced the consumption of plastic material to 75-90%. The match of parameters between plastic molding machine and mold has been carried out. The statistical analysis methods applied for the definition of abovementioned parameters and errors are found in this research.

Application of KBS and ES methods for mold design and definition of its parameters can be supported and provided in two situations: first in the choice of relevant and available information, second, in the choice of tools which can be used to apply this information, and in the interpretation and estimation of results.

3. Expert system architecture for mold design

Our development consists of two parts: 1) general ES architecture created on the macro level for injection mold design, and 2) knowledge-based system for the definition of a cavity number to injection mold design.

ES architecture is presented on the Fig. 1. It consists of four subsystems:

1. cavity number definition;
2. feed system definition;
3. cooling system definition;
4. molded part withdrawal.

The created ES is appointed to the design of injection molds applying artificial intelligence for parts from thermoplastics. The input data for injection mold design is part’s production volume and delivery time, its geometrical form, dimensions, mass and quantitative-qualitative parameters and moulding machine characteristics as well. According to these data the injection mold parameters are defined. Four interfaces in ES architecture are developed to guarantee of subsystems the independence and consequence work. Each subsystem has its own knowledge base, inference engine and database. Inference engine and knowledge base provide solutions to user via user interface. There is dual possibility of data control – automatical and manual.

Table 2
The advantages and disadvantages of knowledge processing

	Advantages	Disadvantages
Fuzzy - heuristic	Expressive Widely used Well compiled Effectively handled and easy broadened	It is necessary to provide practical knowledge It is expensive to estimate and check the factors uncertainty It is difficult to formalize data with complicated structure
Case-based reasoning (CBR)	Easy to dispose and to apply Easy to complete Easy to statistically estimate	It is complicated to present links in chains It is hard to check CBR work
Modeling	It demands high investments to develop	It is often used a part of model only

Leading aspect of developed ES structure is the presentation of necessary knowledge and their processing in injection mold design. Three methods are used for knowledge presentation and processing – fuzzy-heuristic, case-based reasoning (CBR) and modeling. The advantages and disadvantages of abovementioned methods are presented in Table 2. The knowledge and design methods applied in each ES subsystem are very different, therefore, each subunit has its own knowledge base.

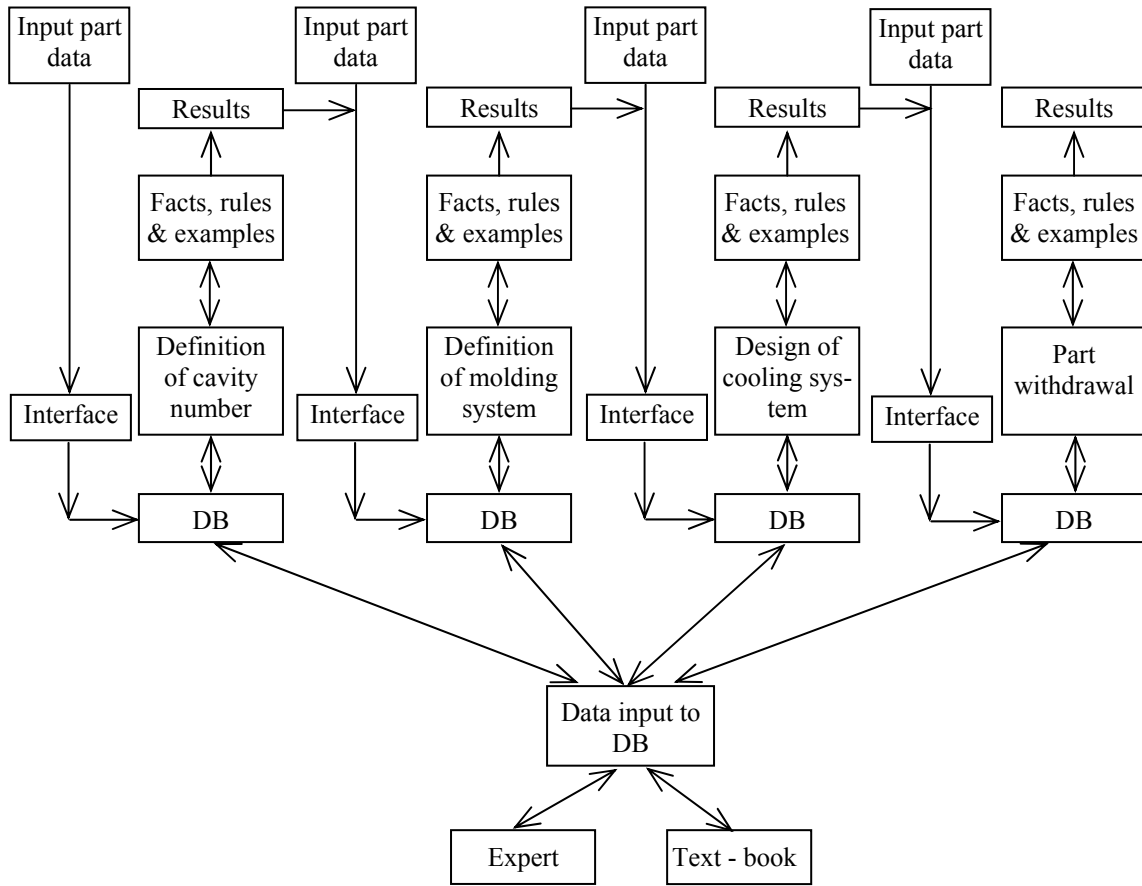

Fig. 1 Expert system structure of mould design

3.1. Knowledge-based method for cavity number definition in injection mold design

Cavity number in injection mold design is one of key factor, because it determines the mold dimensions, mold and part manufacturing cost, and at least part delivery time to customer.

Knowledge-based method for cavity number definition was applied and analytical, fuzzy-heuristic and case-based reasoning manners for necessary knowledge, facts and data acquiring were used.

This task included consideration of undefined variables as follows.

- Variable that estimates part delivery time to customer n_t , which indicates how many parts it is necessary to mold contemporaneously.
- Variable that estimates the complexity of mold production n_g .
- Variable that estimates the qualitative cavity number n_q of mold; it indicates how many parts it is possible to mold contemporaneously with good quality. Variables n_t and n_g in accordance with methodology [11] are as follows

$$n_t = \frac{K_A t_c L}{t_l} \quad (1)$$

$$n_g = \frac{K_A t_c L}{0.7 t_g} \quad (2)$$

where K_A is defect factor; t_c is part mold cycle time; L is production volume; t_l is part production volume delivery time to customer; t_g is one cavity mold manufacturing time.

The variable of mold qualitative cavity number n_q is defined by the experience of designer [11], unfortunately, this is not good-based practice in many cases in particular for small and medium enterprises and when the designer has not enough experience.

On the other hand the mold cavity number according to the alone variable of qualitative cavity number would be not suitably grounded, therefore in this paper the mentioned parameter is defined by three criterions as follows: 1) relation among cavities maximum area S_{II} clamping force and mold internal pressure, 2) maximum part mass m_D and 3) molding machine dimensions S_p .

3.1.1. Definition of mold cavity number according to the clamping force

The mold cavity number according to the clamping force is available for analytical definition [2], but to use this definition automatically is unconvient and difficult, therefore Fuzzy theory [12, 13] for this aim in this paper was applied. The results received by Fuzzy theory are available to express graphically and digitaly. This possibility can simplify and it makes easy to understand the design results.

Fuzzy theory and logic for various engineering and design tasks can be used by Fuzzy-Control structure (Fig. 2).



Fig. 2 Fuzzy – Control structure

Fuzzification is called a procedure when objective variables are described by mathematical expressions and functions (Fig. 3 and Fig. 4). Fuzzification process is as follows:

- definition of lots;
- definition of dependency function.

In the case of mold cavity number definition according to clamping force the fuzzification process of internal mold pressure p was carried out as follows: according to the data in sources [2, 11] it was stated that p fluctuated in the range of 100 – 700 MPa. It was stated, if $p = 0$ MPa, so quantity $\mu = 0$ and when $p = 700$ MPa, so $\mu = 1$ and applying these data the dependency among mold internal pressure and μ was created (Fig. 3).

Clamping force F via μ and molding machine type were expressed as follows: to the molding machine M_1 (Table 4) when $F_{min} = 0$ kN, that $\mu = 1$, and when $F_{max} = 600$ kN, that $\mu = 0$.

The same methodology was used obtaining dependences to the rest molding machines (Table 3) and keeping consecutive variation of clamping force from 0 to 3500 kN (Fig. 4), and holding continuity of clamping force among molding machines. Such continuity dependences have been formulated applying the following expressions

$$\left. \begin{aligned} F_{min(i)} &= F_{max(i-1)} - k, \text{ when } \mu = 0 \\ F_{vid(i)} &= F_{max(i-1)}, \text{ when } \mu = 1 \\ F_{max(i)} &= F_{max(i)}, \text{ when } \mu = 0 \end{aligned} \right\} \quad (3)$$

where i is molding machine from number 2 to j ; j is molding machines number; k is coefficient evaluating the coincidence of clamping forces among different molding machines. It estimates the secure coincidence interval of clamping forces of applied molding machines going from force minimum to maximum, and it is used in this research 250 kN.

The clamping force values of molding machines are calculated using expression (3) and their graphical form is presented in Fig. 3.

The dependence of available molding area S_{II} for considered machines (Table 3) has been calculated using the methodology presented in source [2]

$$S_{II} = \frac{F_{max}}{p} \quad (4)$$

It varies from 0 to 350 cm² for all considered machines and graphical dependencies are analogous as clamping force.

Inference section is divided to hold the created rules and dependences (Table 4); the inference section was created applying the following procedures:

- rules development;
- definition of operators "and", "or", "if" and so on.

Table 3

Molding machines' characteristics

Mark	Moulding machines	Clamp- ing force F , kN	Srew diame- ter D , mm	Clearance between tie bars $b \times l$, mm
M_1	ALLRounder 370 S 600-350	600	55	570x570
M_2	ALLRounder 420 S 800-350	800	45	570x570
M_3	ALLRounder 420 S 600-675	800	55	570x570
M_4	MAXIMA MV 200-1540	2000	70	560x560
M_5	MAXIMA MV 350-1540	3500	70	710x710

Table 4

Inference rules fragment among molding machines, internal pressure and available moulding area

Pres sure	Machine				
	M_1	M_2	M_3	M_4	M_5
p	cavities area is R_1	cavities area is R_2	cavities area is R_3	cavities area is R_4	cavities area is R_5

Defuzzification section is divided to define the mold design parameters as follows:

- defuzzification method selection;
- results submission.

In this paper linear defuzzification procedure finding parameter maximum and minimum values [14] has been chosen. The advantages of this method as simple calculation procedure and simple programming task could be expressed. Applying this method mold internal pressure has been calculated as follows

$$S_{II} = y_0 + (1 - \mu_r)(y_{max} - y_0) \quad (5)$$

where y_0 is minimum value of initial molded area for the appropriate molding machine when $\mu = 1$; y_{max} is maximum value of initial molded area for an appropriate molding machine when $\mu = 0$; μ_r is real μ value defined according to fuzzification and inference interfacing (Fig. 4 and Fig. 5).

When maximum available molding area is defined according to the clamping force and internal pressure then maximum number n_s of consiguently-molded parts can be calculated

$$n_s = \frac{S_{II}}{S_d} \quad (6)$$

3.1.2. Definition of mold cavity number according to maximum molded part mass

Molded part mass is another important parameter influencing the cavity number in mold design. The molding machine type and molded material together with part mass are the necessary data and knowledge for decision-making. ES structure (Fig. 1) contains two databases (DB)

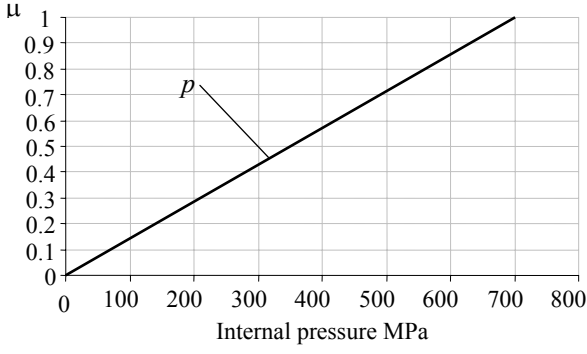

Fig. 3 Internal pressure fuzzification

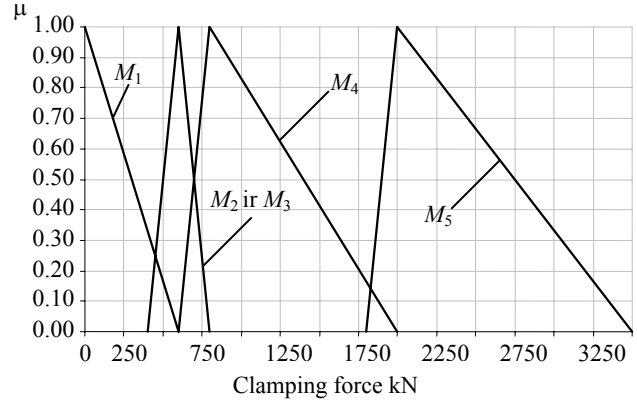

Fig. 4 Clamping force fuzzification

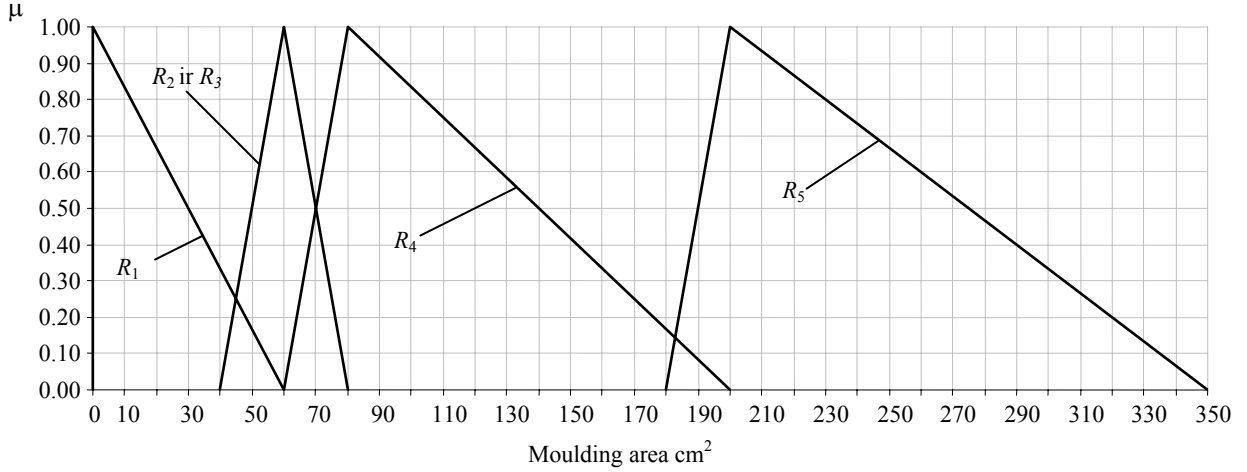

Fig. 5 Moulding area fuzzification

about available moulding machines and materials, which are used for the definition of molded maximum mass m_D and cavity number n_m [2]

$$m_D = 0.75D^2\pi\rho \quad (7)$$

where D is screw diameter; ρ is material density.

$$n_m = \frac{m_D}{m} \quad (8)$$

where m is real molded part mass.

Essential data for expressions (7) and (8) are selected automatically by established rules without designer participation. The rules fragment applying *if-then* operator is as follows.

1. If molding machine M_1 is applied and part material is DM_1 , then screw diameter is D_1 and material density is ρ_1 and maximum part mass is m_D .
2. If molding machine M_2 is applied and part material is DM_1 , then screw diameter is D_2 and material density is ρ_1 and maximum part mass is m_D .
3. If molding machine M_3 is applied and part material is DM_1 , then screw diameter is D_3 and material density is ρ_1 and maximum part mass is m_D .
4. If molding machine M_3 is applied and part material is DM_2 , then screw diameter is D_3 and material density is ρ_2 and maximum part mass is m_D .

3.1.3. Definition of cavity number according to the mold-

ing machine dimensions

The useful working area of moulding machine is significant constrain seeking optimum cavity numbers in mold design. It is necessary to calculate maximum molding plate area S_p of molding machine, which constrains the available cavity number in the mold

$$S_p = kb_p l_p \quad (9)$$

where k is coefficient estimating parameters of feed, cooling and injections systems; b_p ir l_p are maximum length and width of mold area.

Essential data for expression (9) is selected automatically by established rules without designer participation. The rules fragment applying *if...then* operator is as follows.

1. If maximum mold plate area is ≤ 313600 and mold feed canal is trapezium then $k=0.7$;
2. If maximum mold plate area is ≤ 324900 and mold feed canal is trapezium then $k=0.75$;
3. If maximum mold plate area is ≤ 504100 and mold feed canal is trapezium then $k=0.8$;
4. If maximum mold plate area is ≤ 324900 and mold feed canal is round then $k=0.85$;
5. If maximum mold plate area is ≤ 504100 and mold feed canal is round then $k=0.9$;

The available cavity number n_{sk} according to maximum molding plate area S_p is calculated as follows

$$n_{sk} = \frac{S_p}{S_d} \quad (10)$$

where S_d is part maximum area.

A variable that estimates the qualitative cavity number n_q is defined as follows

$$n_q = \min(n_s, n_m, n_{sk}) \quad (11)$$

4. Case study

Theoretical part of this paper developed knowledge – based method for the definition of cavity number in injection mold design. Case study presents experimental investigations of the developed method and discussion of the results. The experimental data of Company X including available moulding machines (M_1, M_2, M_3, M_4, M_5) have been used. Part initial data are illustrated in Tables 3 and 5, and Fig. 6.

Table 5

Part dimensions

Diameter, mm	Height, mm	Part area, mm ²	Part mass, g
12.5	6.2	120	3.05

First stage of experimental investigations is the definition of mold cavity number according to part delivery time n_t and mold complexity n_g . After estimation of these data, the qualitative cavity number n_q was defined according to molded part mass, molding machine dimensions and clamping force. Variables n_t and n_g are calculated by Eqs. 7-10; cavity number is defined according to clamping force by developed Fuzzy method, which is considered here more in detailed case.

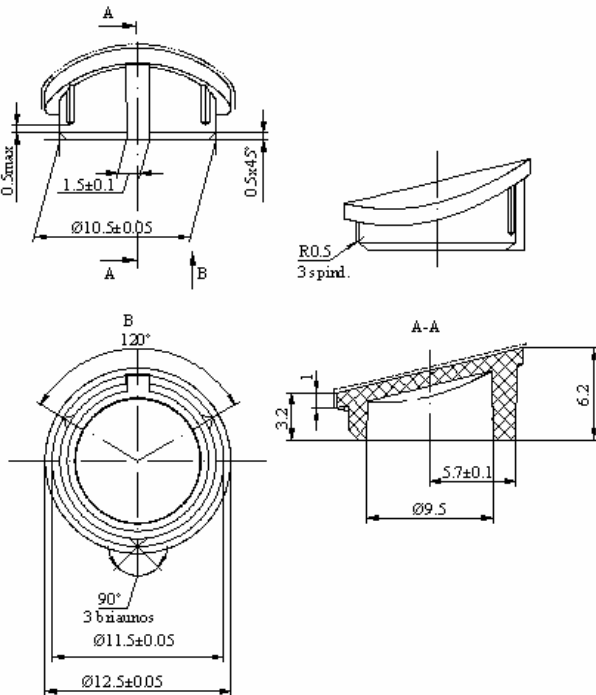

Fig. 6 Moulded part 3D CAD model

Table 6

Experiment initial data

	Part	Production volume	Delivery time	Material
1	Cover	50.000	6 months	PA
2	Cover	100.000	6 months	PA
3	Cover	250.000	12 months	PA
4	Cover	100.000	12 months	PA
5	Cover	100.000	15 months	PA

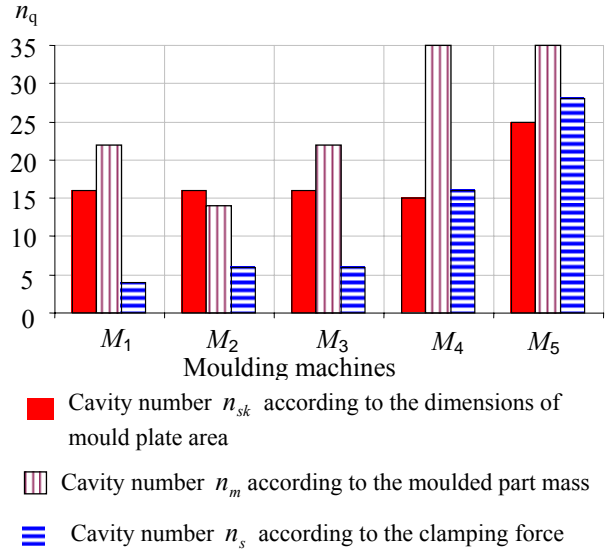

Fig. 7 Definition of mold cavities number according to the molded part quality requirements

The molding machine M_1 for the considered molded part (Fig. 6) was selected; internal pressure in this case is $p = 100$ MPa and maximum clamping force of molding machine M_1 is $F_{max} = 600$ kN, then $\mu_p = 0,15$ (Fig. 3) and $\mu_{M_1} = 0$ (Fig. 4). There is valid first rule that outlines *if M_1 and internal pressure p , then available molded area is R_1* . There is used operator *and*, minimum value of two available alternatives is chosen

$$\min(\mu_p = 0.15 \text{ and } \mu_{M_1} = 0) = 0.$$

Maximum molded area S_{II} of molding machine M_1 have been calculated by graphic (Fig. 5) and expression (5) as

$$S_{II} = 0 + (1 - 0)(60 - 0) = 60 \text{ cm}^2$$

Maximum molded area of the rest molding machines M_2, M_3, M_4, M_5 is calculated analogously. Data n_t, n_g is n_q are defined by expression 10.

The received testing results of mold cavity number definitions are presented in Figs.7 and 8.

It is necessary to take into account these notes before achieved results estimation:

Determined parameter for molding machine selection is qualitative cavity number n_q ; when $n_q \geq n_t$ and

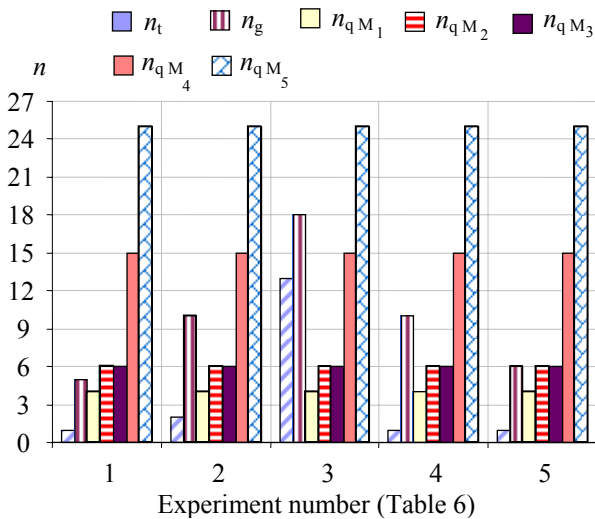

Fig. 8 Experimental results

$n_q \geq n_g$, then such molding machine is available to exploit.

If $n_q \leq n_t$ and $n_q \leq n_g$, then is necessary to increase the molded part delivery time or to take another molding machine.

Concluding the testing results of knowledge-based method (Fig. 8) for the definition of mold cavity number, it is available to outline:

- in the case of experiment 1, the cavity number $n = 5$ and molding machines M_2 and M_3 can be exploited because $n_t = 1$, $n_g = 5$ and $n_q = 6$;
- in the case of experiment 2, the cavity number $n = 10$ and molding machines M_4 can be exploited because $n_t = 2$, $n_g = 10$ and $n_q = 15$;
- in the case of experiment 3, the cavity number $n = 18$ and molding machine M_5 can be exploited because $n_t = 13$, $n_g = 18$ and $n_q = 25$;
- in the case of experiment 4, the cavity number $n = 10$ and molding machine M_4 can be exploited because $n_t = 1$, $n_g = 10$ and $n_q = 15$;
- in the case of experiment 5, the cavity number $n = 6$ and molding machines M_2 and M_3 can be exploited because $n_t = 1$, $n_g = 6$ and $n_q = 6$.

5. Further research

On the base of this research, it is planned to investigate other possibility to use artificial intelligence (AI) for design feed, cooling and ejection systems in injection mold design.

6. Conclusions

The development of an expert system structure for injection mold design and knowledge-based method for definition of mold cavity number has been described in this paper. Injection mold design generally involves complex and multirelated design problems and thus has a complete qualitative and structured approach. The structure of presented expert system facilitates the design procedure of injection mold, finding mold elements data by the knowl-

edge-based solutions and their final development into a finished mold design is left to the mold designer, so that his/her own intelligence and experience could also be incorporated into the total mold design procedure applying standard CAD mold design software. Testing and validation results of knowledge-based method for the definition of mold cavity number showed a good conformity with practical designers' decisions in Company X.

Acknowledgement

This research partially was supported by DAAD scholarship No A/05/03750_323 from October 01, 2005 to July 31, 2006.

References

1. **Scheer A.W.** Factory of the Future. – Saarbrücken, Germany, 1990.-294p.
2. **Johannaber F., Michaeli W.** Handbuch Spritzgießen. –München: Hanser, 2004.-1303p.
3. **Mok C.K., Chin S., Ho K.L.** An Interactive Knowledge-Based CAD System For Mould Design in injection Moulding Processes. – Int. J. Advanced Manufacturing Technology, 2001, v.17, No1, p.27-38.
4. www.fzk.de/pmt (visited 12th November 2005).
5. **Paulmann D.** Klein, kleiner am kleinsten. – Plastverarbeiter.-Heidelberg: Hüthig GmbH & Co, 2005, v.56, No6, p.30-31.
6. <http://www.plasticsportal.net> (visited 16th October 2005).
7. **Schmid L.** Prozesssicher Werkzeugfertigung mit integriertem Fehlermanagementsystem im Werkzeug und Formenbau. –Der Stahlformenbauer- Velbert: Möller, 2005, No5, p.140-142.
8. **Ruprecht R., Bade K., Bauer W.** Mikroabformung in Kunststoff, Metall und Keramik. –Galvanotechnik-München: Eugen G. Leuze Verlag, 2005, No.6, p.1464-1471.
9. www.eurovip.com/opencms/export/euroVIPP/bin/TWR_V1special_injection_technologies.pdf (visited 21st February 2006).
10. **Walter, M., Spennemann, A., Gärtner, R.** Beim Anguss sparen. –Plastverarbeiter.-Heidelberg: Hüthig GmbH & Co, 2002, v.53, No 9, 2002, p.58-60.
11. **Menges G., Michaeli W., Mohren, P.** Anleitung zum Bau von Spritzgießwerkzeugen. –München: Hanser, 1999.-669 p.
12. **Traeger H.** Einführung in die Fuzzy-logik. –Stuttgart: B.G.Teubner, 1994.-176p.
13. **Ayyub B.M.** Elicitation of Expert Opinions for Uncertainty and Risks. –New York: CRC Press, 2001.-302p.
14. **Kahlert, J., Hubert F.** Fuzzy-logik und Fuzzy-control. –Vieweg: Wiesbaden, 1993.-339p.

Ž. Rutkauskas, A. Bargelis, G. Linß

LIEJAMOJO PRESAVIMO FORMOS LIEJIMO LIZDŲ SKAIČIAUS NUSTATYMAS ŽINIŲ BAZĖS METODU

R e z i u m ė

Nagrinėjamas intelektualių sistemų panaudojimas

liejimo formų projektavimui automatizuoti. Sukurta ekspertinė sistemos struktūra liejimo formoms projektuoti. Ją sudaro keturios sudedamosios dalys: liejimo lizdų skaičiaus nustatymas, liejimo sistemos parinkimas, aušinimo sistema, detalės išėmimas. Straipsnyje plačiau išnagrinėtas liejamojo presavimo formos liejimo lizdų skaičiaus nustatymas. Duomenims pavaizduoti ir apdoroti buvo panaudotas žinių bazės metodas ir Fuzzi teorija. Sukurtos žinių bazės metodo patikimumas formos liejimo lizdų skaičiui nustatyti buvo patikrintas eksperimentiniais tyrimais ir priėmimo bandymais.

Ž. Rutkauskas, A. Bargelis, G. Linš

KNOWLEDGE-BASED METHOD FOR CAVITY NUMBER DEFINITION IN INJECTION MOLD DESIGN

S u m m a r y

This paper deals with the application of intelligent design system for injection mold design. Expert System structure to injection mold design is developed. It consists of four parts: definition of cavity number, feeding system, cooling system, and molded part withdrawal. The definition of mold cavity number is widely considered. The

knowledge-based method and Fuzzy theory for data presentation and knowledge processing have been used. The developed knowledge-based method for the definition of cavity number has been tested and validated experimentally.

Ж. Руткаускас, А. Баргялис, Г. Линс

МЕТОД ЗНАНИЯ ДЛЯ ОПРЕДЕЛЕНИЯ ЧИСЛА ЛИТЕЙНЫХ ГНЕЗД ЛИТЕЙНЫХ ПРЕССФОРМ

Р е з ю м е

В статье рассматривается использование интеллектуальных систем в процессе проектирования литейных прессформ. Создана структура экспертной системы проектирования литейных форм. Она состоит из четырех частей: определения числа литейных гнезд, выбора системы литья, системы охлаждения, снятия детали из формы. Для представления данных и их обработки использовались метод базы знания и Фуззи теория. Надежность созданного метода знаний для определения числа литейных гнезд была проверена и утверждена путем экспериментальных исследований.

Received September 28, 2006

DOI: 10.5755/j02.mech.14769