

Motion of elastically and damping constrained part on a horizontally vibrating plane

B. Bakšys*, K. Ramanauskytė**

*Kaunas University of Technology, Kęstučio 27, 44025 Kaunas, Lithuania, E-mail: Bronius.Baksys@ktu.lt

**Kaunas University of Technology, Kęstučio 27, 44025 Kaunas, Lithuania, E-mail: Kristina.Ramanauskyte@stud.ktu.lt

1. Introduction

For assembly automation it is necessary to perform parts feeding into assembly position, orienting and positioning, matching of the connective surfaces and joining operations and removal of assembled units from the working area [1]. Matching of connective surfaces is the main stage of the automated assembly as parts get such interdependent position, that their unhindered joining is possible. During vibratory assembly the parts need to be positioned with particular precision to the necessary place, oriented in respect of each other to eliminate error of positioning and their connective surfaces should be matched. For matching of the parts connective surfaces the search method may be used [1]. During the search one of the parts must move by predefined trajectory relative to the other part on a plane perpendicular to an assembly axis. The center of the mating part must fall into the zone of allowable error, which is characterized by the clearance between the parts to be assembled. It is possible to provide one of the parts with search motion by robot or manipulator, but more simple and cheaper is the method of vibratory search, based on part motion on a horizontally vibrating plane. Providing vibrations to the plane due to friction forces between the surfaces of the part and the plane the part can move by complex trajectories or rotate about the particular point thus performing search motion.

Previous work [2] analyzes mating of connective surfaces of the parts, when one of the mating part moves unstrained on the horizontally vibrating plane. Using this search method the part resting on the plane is preliminary positioned in respect of the other part and then performs search motion. Positioning takes place under transitional state of part movement, while search occurs at steady state, when the part starts moving by circular, elliptic, straight or by complex trajectory.

Vibrations are widely applied not only for vibratory search but also for assorted parts transportation. Vibratory conveyors are used to move granular products or similar parts. Frei P. analyzes a conveyor, which moves large amount of objects in different trajectories [3,4]. Conveyor's plane consist of cells, which are exited both horizontally (in two perpendicular directions) and vertically. Vertical motion drive is attached to each cell. By changing excitation point of a cell, motion direction of a part is changed. Thus arranging, orienting, feeding and sorting of parts is possible. Bohringer K.-F. proposed a device for parts orienting consisting of vibration generator and flat aluminum plate [5]. The plate can be attached to an oscillator in two ways. Part orientation and location order depends on the method of fixing. Fedaravičius A. ir Tarasevičius K investigated part motion on vibrating plane,

when during each rotation of vibrating platform the effect of friction coefficient is controlled periodically [6]. Circular motion is provided to the plane. Controlling Coulomb friction it is possible to transport bodies by complex trajectory, change motion direction and velocity. Both the mathematical and dynamic models were build and experiments were performed. It was determined by experiments that it is possible to control easily a part motion in desirable direction and change the velocity of transportation increasing or decreasing duration of high frequency vibrations and varying radius of platform motion by circular trajectory. In such a way manipulation and orientation of the parts is possible. But regarding to automated assembly the main stage of connective surfaces matching by the method of vibratory search was not analyzed.

In this paper vibratory search method based on a part motion on a horizontally vibrating plane is investigated, when the part has elastic and damping constraints in all directions. Such assembly method is applied when one of the parts on horizontally vibrating plane is mobile based.

2. Motion of a part on a plane under constant pressing force of the peg

Investigated is a case, when during assembly one mating part (in this case a peg) is fed into assembly position by a manipulator or robot and the other part (bushing) is mobile based on the plane. Due to positioning error of the robot the part has interdependent misalignment in the assembly position. Having an aim to eliminate the error of positioning horizontal motion vibratory excitation is provided to the bushing, witch has elastic and damping constraints in all directions (Fig. 1).

Motion of constrained bushing on a horizontally vibrating plane is expressed by the equations:

$$\left. \begin{aligned} m\ddot{x} + \mu(mg + F) \frac{\dot{x}}{\sqrt{\dot{x}^2 + \dot{y}^2}} + h_x \dot{x} + c_x x &= mR_e \omega^2 \cos \omega t \\ m\ddot{y} + \mu(mg + F) \frac{\dot{y}}{\sqrt{\dot{x}^2 + \dot{y}^2}} + h_y \dot{y} + c_y y &= mR_e \omega^2 \sin \omega t \end{aligned} \right\} (1)$$

where m is mass of the part, μ is friction coefficient between the bushing and the plane, g is acceleration of gravity, F is pressing force, R_e is excitation amplitude, ω is frequency of harmonic motion, t is time, $h_x = h_{x1} + h_{x2}$, $h_y = h_{y1} + h_{y2}$ are damping coefficients along x and y axis direction respectively, $c_x = c_{x1} + c_{x2}$, $c_y = c_{y1} + c_{y2}$ is

rigidity of the spring along the direction of x and y axis respectively.

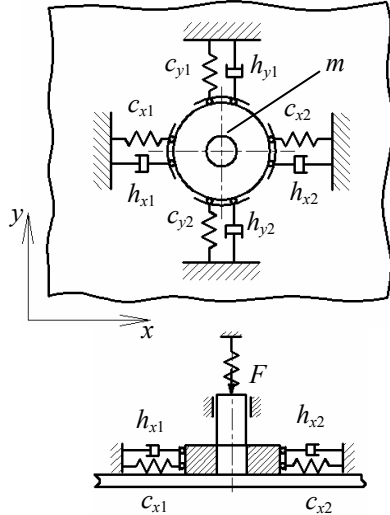

Fig. 1 Scheme of vibratory search

In order to solve Eq. (1) calculation program was written applying MATLAB software. The examples of part's center motion trajectories along x and y directions are shown in Fig. 2, and part's motion trajectories in xyt coordinate system are given in Fig. 3. The part in xt plane moves by a complex trajectory from initial point to a particular point, which is predetermined by parameters of the system. We would call this regime as sliding by transitional motion. Later the part returns back and gets steady motion by circular trajectory in respect of initial point. The trajectory of part movement, while steady circular motion is obtained, may be of different character. Both the displacement of the part during transitional state and radius of circular motion depend on rigidity of resilient elements, initial velocity, coefficient of friction and excitation frequency.

Before circular search trajectory is obtained, part slides on the plane performing some loops. Therefore, probability increases that center of the part gets into the zone of allowable error.

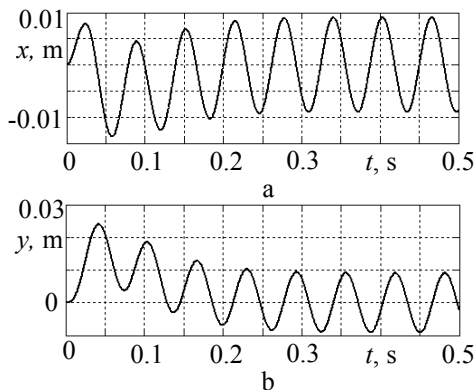

Fig. 2 Characteristic vibrations of the part, as $m=0.01$ kg, $F=2$ N, $h_x=h_y=0.2$ Ns/m, $c_x=c_y=10$ N/m, $\mu=0.1$, $R_e=0.01$ m, $\omega=200$ s $^{-1}$: a - along the x axis direction, b - along the y axis direction

The trajectory of part motion may be varied by changing the coefficient of friction μ , excitation frequency ω and amplitude R_e (Fig. 4). By increasing the coefficient

of friction μ , displacement of the part from the initial position to the farthest approachable point gets shorter (Fig. 4, a, b). When $\mu=0.1$, the part moves by a helical twisting trajectory (Fig. 4, c), and at further increasing the coefficient of friction, the part is no longer sliding, but only rotates circularly (Fig. 4, d). When choosing the higher values of excitation frequency and/or amplitude the part resumes moving by translational circular trajectory.

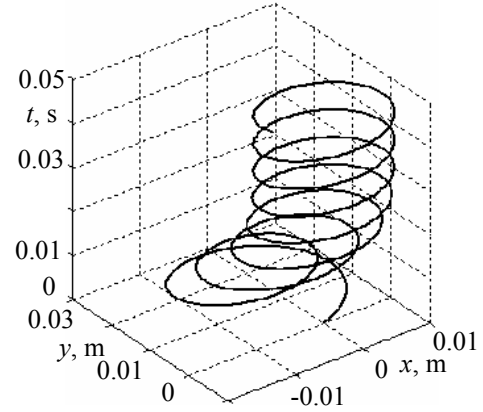

Fig. 3 Trajectory of part motion in xyt coordinate system

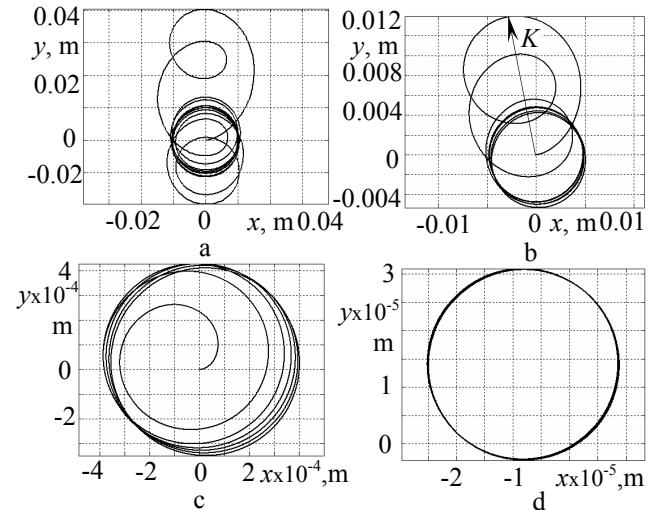

Fig. 4 Character of trajectories on xy plane, as $R_e=0.01$ m, $m=0.01$ m, $F=5$ N, $h_x=h_y=0.2$ Ns/m, $c_x=c_y=10$ N/m, $\omega=180$ s $^{-1}$: a - $\mu=0.01$, b - $\mu=0.1$, c - $\mu=0.45$, d - $\mu=0.63$

Considering the character of motion trajectories it is possible to identify 5 regimes of the part motion, taking into account the sets of parameters F and μ , F and R_e , c and R_e , c and ω . Zones of occurrence, where such regimes exist, were determined (Figs. 5-8).

With given parameters from the first zone the part initially moves by a looping trajectory backwards and forwards in respect of initial point, which later changes into circular motion (Fig. 4, a). In the second zone characteristic for the part is the motion, when it rotates circularly and slides, though sliding backwards and forwards is already not present (Fig. 4, b). In the third zone the part has characteristic helical unwinding motion (Fig. 4, c). The fourth zone characterizes circular motion of the part (Fig. 4, d). When the parameters are within the fifth zone, the part moves chaotically with small amplitude.

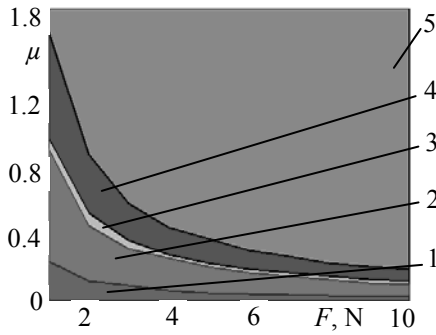

Fig. 5 Zones of motion regimes in coordinates F and μ , as $\omega=150 \text{ s}^{-1}$, $m=0.01 \text{ kg}$, $R_e=0.005 \text{ m}$, $h_x=h_y=0.2 \text{ Ns/m}$, $c_x=c_y=10 \text{ N/m}$,

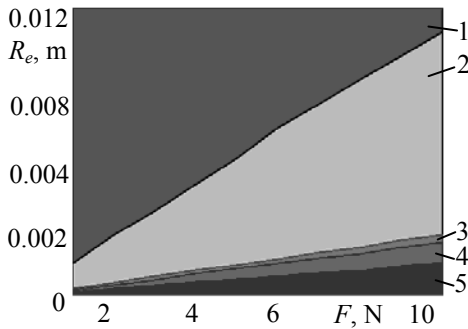

Fig. 6 Zones of motion regimes in coordinates F and R_e , as $\omega=150 \text{ s}^{-1}$, $\mu=0.05$, $h_x=h_y=0.2 \text{ Ns/m}$, $c_x=c_y=10 \text{ N/m}$, $m=0.01 \text{ kg}$

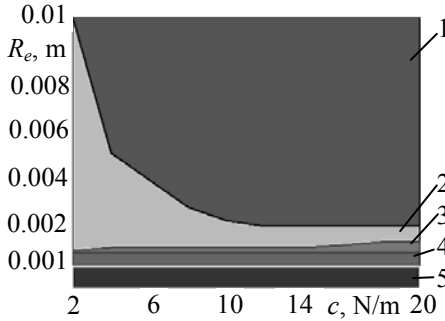

Fig. 7 Zones of motion regimes in coordinates c and R_e , as $\omega=150 \text{ s}^{-1}$, $\mu=0.1$, $m=0.01 \text{ kg}$, $F=3 \text{ N}$; $c=c_x=c_y$, $h_x=h_y=0.2 \text{ Ns/m}$

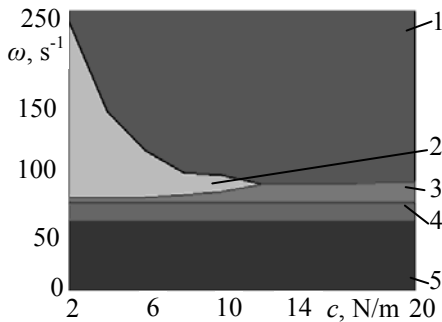

Fig. 8 Zones of motion regimes in coordinates c and ω , as $R_e=0.005 \text{ m}$, $\mu=0.1$, $h_x=h_y=0.2 \text{ Ns/m}$, $m=0.01 \text{ kg}$, $F=3 \text{ N}$; $c=c_x=c_y$

In Fig. 5 the bigger zone is fifth, as the part on the plane moves chaotically. In Figs. 6 and 7 the biggest zones are first and second, as the part on the plane moves by transitional motion regime and then steady state of cylindrical search motion is obtained. Second zone, shown in coordinates c and ω (Fig. 8), exists only under smaller values of spring rigidity. As spring rigidity decreases, frequency range, where the second zone exists, increases.

As interdependent position error of connective surfaces is higher, it is important to know what furthest distance from the initial point the part can move. All parameters of the system have influence on covered distance, but a higher influence has both the excitation amplitude R_e and frequency ω . It was determined, that as excitation amplitude increases, part's displacement K increases more rapidly, and by increasing friction coefficient – K decreases (Fig. 9). As excitation frequency increases part motion increase is faster (Fig. 10).

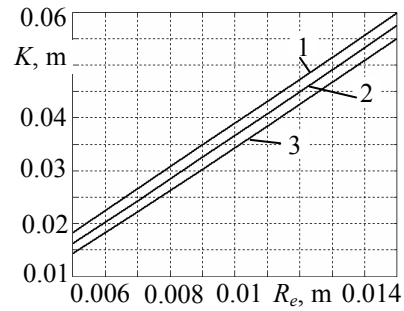

Fig. 9 Dependence of part displacement both on excitation amplitude R_e and friction coefficient μ , as $F=2 \text{ N}$, $m=0.01 \text{ kg}$, $h_x=h_y=0.2 \text{ Ns/m}$, $c_x=c_y=10 \text{ N/m}$, $\omega=150 \text{ s}^{-1}$: 1 - $\mu=0.05$, 2 - $\mu=0.1$, 3 - $\mu=0.15$

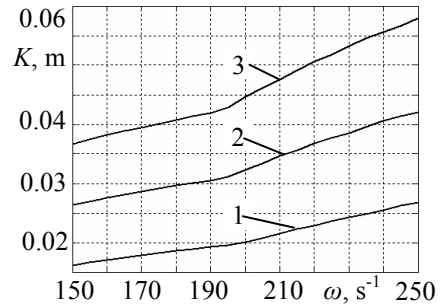

Fig. 10 Dependence of part displacement both on excitation frequency ω and amplitude R_e , as $\mu=0.1$, $h_x=h_y=0.2 \text{ Ns/m}$, $c_x=c_y=10 \text{ N/m}$, $m=0.01 \text{ kg}$, $F=2 \text{ N}$: 1 - $R_e=0.005 \text{ m}$; 2 - $R_e=0.0075 \text{ m}$; 3 - $R_e=0.01 \text{ m}$

With the given elliptical trajectory, a higher probability exists for the axis of the bushing to fall into the allowable error zone, than with the given cylindrical trajectory. If minor axis of the ellipse is smaller than the diameter of allowable error zone the part center will cross the mentioned zone twice during one rotation cycle. In order to obtain elliptic trajectory of the part movement it is necessary to provide elliptic motion to the plane. This could be obtained in two ways: exciting the plane along one of the axis by higher amplitude than along the other axis (Fig. 11) or with the given different rigidity of the spring along the directions of x and y axis.

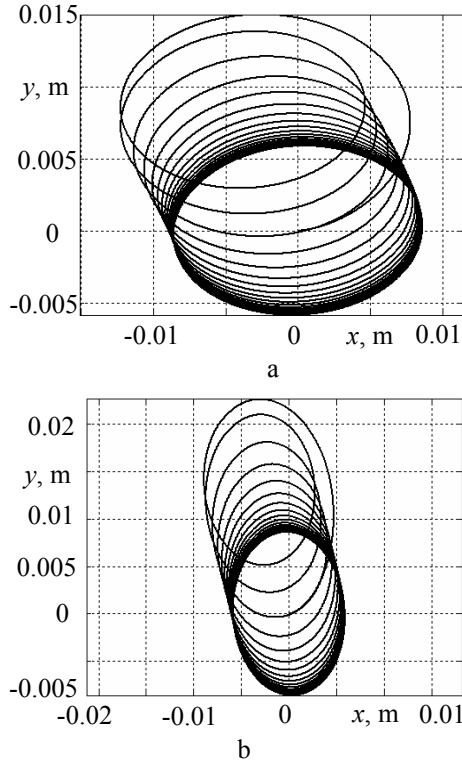

Fig. 11 Part motion trajectory, as plane is vibrated by elliptical mode: a - as amplitude along the x axis direction is higher than the amplitude along the y axis direction; b - as amplitude along the y axis direction is higher than the amplitude along the x axis direction

The character of transitional motion regime, which describes movement of the part, while the plane moves along elliptical or circular trajectory, practically has no differences.

3. Motion of a part on a plane under varying pressing force

With the given steady excitation frequency of the plane closed trajectory is obtained. During the search decrement amplitude of the helical interwinding trajectory is obtained. In such a way the probability that the center of vibrating bushing would fall into allowable error zone increases. It is possible to decrease the amplitude by increasing friction force between mating parts, i. e. progressively increasing pressing force of the peg (Fig. 12).

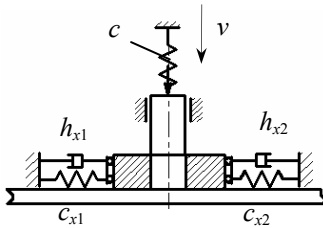

Fig. 12 Scheme used to set varying pressing force

Then motion equations of the constrained bushing on a horizontal plane could be written:

$$\left. \begin{aligned} m\ddot{x} + \mu F_1 \frac{\dot{x}}{\sqrt{\dot{x}^2 + \dot{y}^2}} + h_x \dot{x} + c_x x &= mR_e \omega^2 \cos \omega t \\ m\ddot{y} + \mu F_1 \frac{\dot{y}}{\sqrt{\dot{x}^2 + \dot{y}^2}} + h_y \dot{y} + c_y y &= mR_e \omega^2 \sin \omega t \end{aligned} \right\} \quad (2)$$

where $F_1 = mg + cvt$, c is rigidity of the spring for pressing of the peg, v is pressing velocity.

Motion trajectories of part's center along x and y directions are shown in Fig. 13 and here we can see that over the time under increased pressing force, herewith friction force, the amplitude gets decreased.

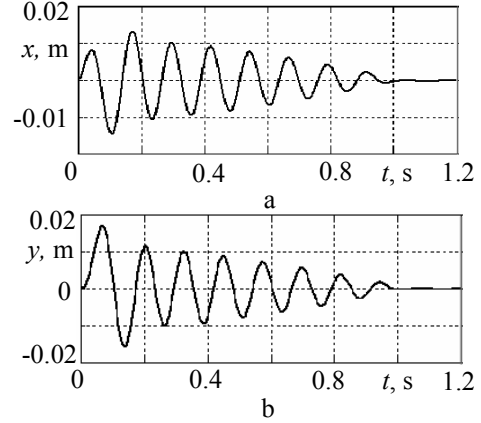

Fig. 13 Character of part vibrations, as $m=0.01$ kg, $v=0.08$ m/s, $c=15$ N/m, $R_e=0.01$ m, $\omega=50$ s⁻¹, $\mu=0.01$, $h_x=h_y=0.2$ Ns/m, $c_x=c_y=10$ N/m; a - along the x axis direction, b - along the y axis direction

It is seen from 3-D graph (Fig. 14) that as the amplitude constantly decreases, motion trajectory of the part is of interwinding helix form.

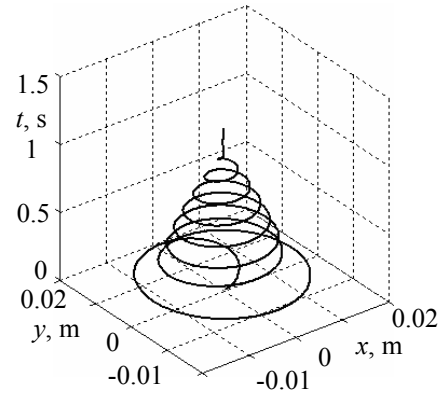

Fig. 14 Motion trajectory of the part under varying pressing force

Dependencies of the part stopping time on various parameters of the system are presented in Figs. 15-17. When rigidity of the spring pressing the peg increases, the time as part stops decreases, while increasing excitation amplitude – the mentioned time increases (Fig. 15). As peg's pressing velocity increases, the time gets shorter, and as excitation frequency increases – it gets longer (Fig. 16). Therefore, by increasing both the mass of the bushing and friction coefficient, the time as the part stops decreases (Fig. 17).

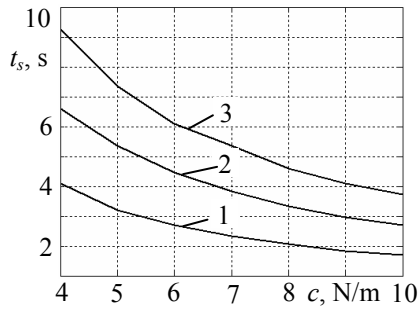

Fig. 15 Dependence of time as part stops on peg's pressing spring rigidity c and excitation amplitude R_e , as $m=0.005$ kg, $v=0.005$ m/s, $h_x=h_y=0.2$ Ns/m, $c_x=c_y=10$ N/m, $\mu=0.3$, $\omega=50$ s⁻¹: 1 - $R_e=0.005$ m, 2 - $R_e=0.0075$ m, 3 - $R_e=0.01$ m

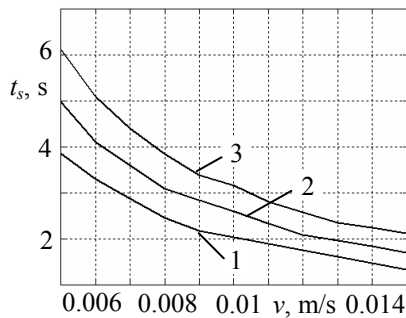

Fig. 16 Dependence of time as part stops, on peg's pressing velocity v and excitation frequency ω , as $m=0.005$ kg, $\mu=0.3$, $c=15$ N/m, $h_x=h_y=0.2$ Ns/m, $c_x=c_y=10$ N/m, $R_e=0.01$ m: 1 - $\omega=45$ s⁻¹, 2 - $\omega=50$ s⁻¹, 3 - $\omega=55$ s⁻¹

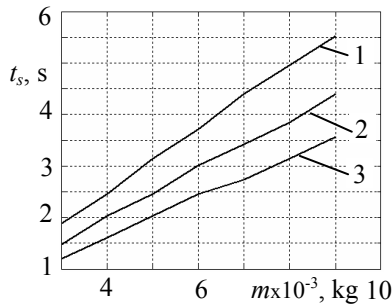

Fig. 17 Dependence of the time the part stops moving both on the bushing's mass m and friction coefficient μ , as $v=0.01$ m/s, $R_e=0.01$ m, $\omega=45$ s⁻¹, $c=15$ N/m, $h_x=h_y=0.2$ Ns/m, $c_x=c_y=10$ N/m, $\omega=45$ s⁻¹: 1 - $\mu=0.2$, 2 - $\mu=0.25$, 3 - $\mu=0.3$

Having magnitude of allowable error zone it is possible to choose the system parameters so that the distance between adjacent loops of interwinding helix (step between them is Δ) is not exceeding allowable error zone 3 (Fig. 18). Then trajectory of the bushing certainly gets into allowable error zone and matching of the parts' surfaces takes place.

It was determined, that interwinding step of the helix increases over the time (Fig.19), while for significantly decreasing amplitude, i.e. as bushing keeps still, – gets equal to zero.

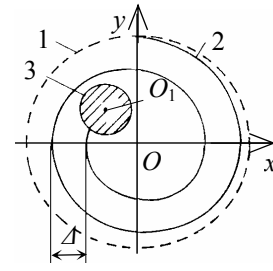

Fig. 18 Search scheme: 1 - circular trajectory; 2 - interwinding helix trajectory; 3 - allowable error zone

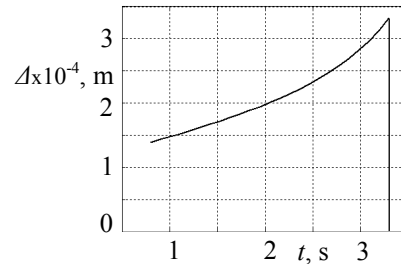

Fig. 19 Change of helix interwinding step, as $v=0.01$ m/s, $\omega=60$ s⁻¹, $R_e=0.005$ m, $c=15$ N/m, $h_x=h_y=0.2$ Ns/m, $c_x=c_y=14$ N/m

4. Conclusions

1. The character of part motion on a vibrating plane was analyzed, as the part has elastic and damping constraints, under constant and varying pressing force of the peg. It was determined that with given constant pressing force the part initially moves by transitional motion regime, which some time later changes into steady motion by circular or elliptical trajectory regime. Under varying pressing force the part moves by interwinding helix till finally stops.

2. Taking into account the sets of parameters F and μ , F and R_e , c and R_e , c and ω 5 regimes of the part motion were identified. The zones, where such regimes exist, were defined. The best conditions for interdependent search of the parts occur if the character of part motion on a vibrating plane is characterized by the first and second zone.

3. It was determined that as excitation amplitude increases, displacement of the part rapidly increases, while as friction coefficient increases – displacement decreases. As excitation frequency increases, displacement of the part increases faster.

4. In order to obtain elliptical trajectory of the part movement it is necessary to excite the plane along one of the axis by higher amplitude than along the other axis or to choose different rigidity of the springs along the x and y directions.

5. It was determined that as pressing force of the peg increases, the amplitude of bushing motion on a plane decreases over the time, while motion trajectory of the part is interwinding helix.

6. The performed analysis showed, that increase in rigidity of the spring pressing the peg shortens the time as the part stops, while increasing excitation amplitude, this time gets longer. As velocity of the peg pressing increases, the time shortens, and as excitation frequency increases – it gets longer. Though as both the mass of the

bushing and friction coefficient increase, the time gets shorter.

References

1. **Bakšys, B., Fedaravičius, A.** Vibratory Systems and Mechanisms for Automated Manipulation.-Kaunas: Technologija, ISBN 9955-09-841-4. 2005.-373p. (in Lithuanian).
2. **Bakšys, B., Ramanauskytė, K.** Motion of the part on a horizontally vibrating plate.-Mechanika.-Kaunas: Technologija, 2005, Nr. 5(55), p.20-26.
3. **Frei, P. U., Weisendanger, M., Buchi, R., Ruf, L.** Simultaneous planar transport of multiple objects on individual trajectories using friction forces.-In K. F. Bohringer and H. Choset, editors, Distributed Manipulation, Kluwer Academic Publishers, 2000, p.49-64.
4. **Frei, P. U.** An intelligent vibratory conveyor for the individual objects transportation in two dimensions.-Proc. of the 2002 IEEE/RSJ Int. Conf. on Intelligent Robots and Systems EPFL, Lausanne, Switzerland, October 2002, p.1832-1837.
5. **Bohringer, K.-F., Bhatt, V., Goldberg, K. Y.** Sensorless manipulation using transverse vibrations of a plate.-Proc. of the IEEE Int. Conf. on Robotics and Automation (ICRA'95).-Nagoya, Japan, May 1995, p.1989-1996.
6. **Fedaravičius, A., Tarasevičius, K.** Dynamic of Vibratory Transportation and Orientation Systems.-Kaunas: Technologija, 1998.-142p. (in Lithuanian).

B. Bakšys, K. Ramanauskytė

TAMPRIAISIAIS IR SLOPINIMO RYŠIAIS SUVARŽYTOS DETALĖS JUDĖJIMAS HORIZONTALIAI VIRPANČIA PLOKŠTUMA

Reziumė

Straipsnyje nagrinėjamas tampriaisiais bei slopinimo ryšiais suvaržytos detalės judėjimas statmena kryptimi žadinama horizontalia plokštuma. Sudaryti vibracinės paieškos matematinis ir dinaminis modeliai, kai veleno prispaudimo jėga yra pastovi ir kai kinta tiesiškai. Naudojantis MatLab paketu parašytos judėjimo lygčių sprendimo programos. Nustatytos detalės, judančios apskritimu žadinama plokštuma, judesio charakteristikos priklausomai nuo trinties koeficiento, žadinimo dažnio bei amplitudės. Atsižvelgiant į sistemos parametrų derinius, išskirtos penkios judesio režimų zonos. Nustatytos sąlygos, kurioms esant gaunamos elipsinės detalės judėjimo trajektorijos. Įrodyta, kad veleną spaudžiant tiesiškai kintama jėga įvorės judesio trajektorija yra susisukanti spiralė. Iširta tampriųjų ryšių standumo, žadinimo amplitudės ir dažnio, veleno prispaudimo greičio, įvorės masės bei trinties koeficiento tarp įvorės ir plokštumos įtaka laikui, per kurį detalė sustoja. Nustatyta, kad spiralės susisukimo žingsnis ilgainiui didėja.

B. Bakšys, K. Ramanauskytė

MOTION OF ELASTICALLY AND DAMPING CONSTRAINED PART ON A HORIZONTALLY VIBRATING PLANE

Summary

Motion of the part on an excited in two perpendicular directions horizontal plane, when the part has elastic and damping constraints, is analyzed in presented paper. Both the mathematical and dynamic models for vibratory search, when pressing force of the peg is constant and changes linearly were formed. Using MatLab software the programs for equations solving were written. Motion characteristics of the part moving on a circularly excited plane, depending on friction coefficient and both on excitation frequency and amplitude, were determined. Taking into account the sets of parameters 5 zones of motion regimes were defined. Conditions necessary to obtain elliptical trajectories of part motion were determined. It was determined, that pressing the peg by changing linearly force the bushing moves by interwinding helix trajectory. The influence of elastic constraints rigidity, excitation amplitude and frequency, pressing velocity of the peg, mass of the bushing and also coefficient of friction between a bushing and a plane on time within which the part stops was investigated. It was determined that interwinding step of the helix increases over the time.

Б. Бакшис, К. Раманауските

ПЕРЕМЕЩЕНИЕ ПО ГОРИЗОНТАЛЬНО ВИБРИРУЮЩЕЙ ПЛОСКОСТИ УПРУГИМИ И ДИССИПАТИВНЫМИ СВЯЗЯМИ ОГРАНИЧЕННОЙ ДЕТАЛИ

Резюме

В статье рассматривается перемещение детали по горизонтальной в перпендикулярных направлениях возбуждаемой плоскости, когда на деталь наложены упругие и диссипативные связи. Составлены динамическая и математическая модели вибрационного поиска при воздействии на вал постоянного и линейно переменного усилия. При использовании пакета MatLab написаны программы решения уравнений движения. Определены характеристики перемещения детали на плоскости, возбуждаемой по окружности в зависимости от коэффициента трения, частоты и амплитуды возбуждения. Учитывая сочетание параметров системы, выделено 5 зон режимов перемещения. Определены условия, при которых деталь перемещается по эллиптической траектории. Выявлено, что при воздействии на вал линейно переменного усилия втулка перемещается по скручивающейся спирали. Исследовано влияние жесткости упругих связей, амплитуды и частоты возбуждения, скорости поджатия вала, массы втулки и коэффициента трения между втулкой и плоскостью на время прекращения перемещения детали. Определено, что с течением времени шаг скручивания спирали увеличивается.

DOI: 10.5755/j02.mech.14772