

Slider-link driven compressor (I). Mathematical model

V. Dagilis*, L. Vaitkus**, D. Kirejchick***

*Kaunas University of Technology, K. Donelaičio g. 20, 44239 Kaunas, Lithuania, E-mail: Vytautas.Dagilis@ktu.lt

**Kaunas University of Technology, K. Donelaičio g. 20, 44239 Kaunas, Lithuania, E-mail: Liutauras.Vaitkus@ktu.lt

***JSC "Atlant", Nakonechnikov 50, 225320 Baranovich, Republic of Byelorussia, E-mail: bsz@atlant.belpak.brest.by

1. Introduction

Most of modern household refrigerating compressors are connecting rod driven reciprocating compressors. Slider-link driven compressors are considered outdated, but still are manufactured and even have some advantages when displacement of the compressors is decreasing. They are compact, light in weight and easy to manufacture.

One of disadvantages of slider-link driven compressors is high losses for friction in a slider – link pair. However, in experiments with the compressors without such losses (the losses were eliminated by the use of connecting rod with spherical joint) a very limited effect was obtained. The measured decrease in power consumption did not exceed 4 W for a compressor with the volume 8 cm³. Transition from slider-link driven design to connecting rod driven design does mean changing of almost all manufacturing equipment. Justification of such investments requires stronger arguments and deeper analysis.

The presented mathematical model was developed with multiple tasks in mind. It can be used by developers of slider-link driven compressors for the calculation of loads on compressor parts, unbalanced inertia forces, losses due to friction, etc. The model is also intended to be used for compressor optimization, i.e. for the selection of such geometrical parameters (piston stroke to diameter ratio, eccentricity of the piston, clearance between the piston and cylinder, etc.), which will ensure the highest efficiency. It may also be helpful in determining the most cost – effective technological improvements. Finally, it could serve as the means to justify transition to connecting rod driven design in case the cost effective development paths for slider-link driven compressors will not be found.

2. Equation of motion of the piston

In the model the orthogonal coordinate system is defined. The x, y, z coordinate is fixed on the cylinder. The origin O lays at the intersection of the crankshaft rotation axis and perpendicular plane, which goes through compressor's mass centre, x axis is parallel to the cylinder axis of symmetry and z axis coincides with the crankshaft rotation axis. The directions of x , y and z are shown in Fig. 1, Fig. 4 and Fig. 5 (the direction of z is downwards).

The main variable is turning angle of the crankshaft with $\varphi = 0$ when the piston is at the upper dead center. φ is defined as positive when the turn is counter clockwise respectively to the coordinate axis z . As the direction of z axis is downwards, in Fig. 1-3 φ is positive when the turn is clockwise.

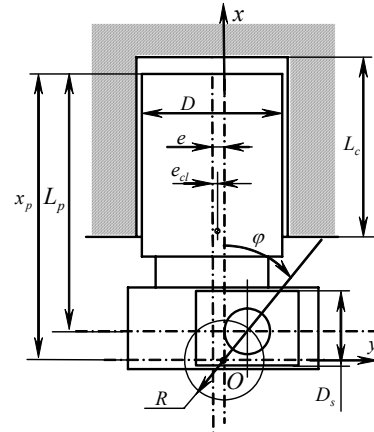

Fig. 1 Coordinate and variables. D is diameter of the piston; L_c is length of the cylinder; L_p is distance from the piston end to the link center axis; e_{cl} is distance from the piston mass center to symmetry axis; x_p is distance from the piston end to rotation axis; D_s is diameter of the slider; e is eccentricity of the link; R is radius of the crankshaft

Fig. 2 shows all the possible forces and the moment exerted on the piston as well as the points at which the forces are exerted. The gas pressure pushes the end of the piston from the side of the cylinder. The constraint forces and the frictional forces arise at contact points with the cylinder and slider. Gas force F_g is given in the following form

$$F_g = (p_c - p_0)A_p \quad (1)$$

where p_c , p_0 are pressure in the cylinder and in the compressor's shell; A_p is area of the piston. If $p_c > p_0$, direction of F_g is opposite to x . Pressure p_0 assumed constant, p_c calculated using the model, described in [1].

Coordinate, velocity and acceleration of the piston in x axis direction are

$$\left. \begin{aligned} x_p &= L_p + R \cos \varphi, \quad \dot{x}_p = -R\dot{\varphi} \sin \varphi \\ \ddot{x}_p &= -R(\dot{\varphi}^2 \cos \varphi + \ddot{\varphi} \sin \varphi) \end{aligned} \right\} \quad (2)$$

Coordinate, velocity and acceleration of the slider in y axis direction are

$$\left. \begin{aligned} y_s &= R \sin \varphi, \quad \dot{y}_s = R\dot{\varphi} \cos \varphi \\ \ddot{y}_s &= -R(\dot{\varphi}^2 \sin \varphi - \ddot{\varphi} \cos \varphi) \end{aligned} \right\} \quad (3)$$

Frictional force exerted on the link from the side of the slider at points B_1 or B_2 is perpendicular to the direction of motion of the piston. The constraint force, which arises at the same points, is parallel to the direction of piston motion, but the point at which the force is exerted is changing as the crankshaft rotates. Therefore the piston center line slightly tilts in clockwise or counter clockwise directions. Note that not all the forces, shown on Fig. 2, arise at the same time. This depends on the direction, in which the piston center line tilts, as well as on the direction of constraint force exerted on the link from the side of the slider.

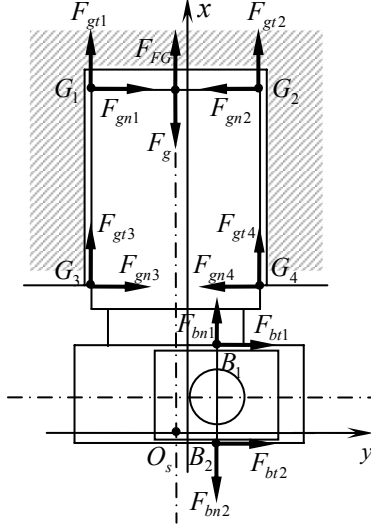

Fig. 2 All the possible forces exerted on the piston

If the piston tilts in counter-clockwise direction then it contacts with the cylinder at G_1 and G_4 points. There constraint forces F_{gn1} and F_{gn4} together with the frictional forces F_{gt1} and F_{gt4} arise. Otherwise, when the piston tilts clockwise, forces F_{gn2} , F_{gn3} , F_{gt2} and F_{gt3} arise at points G_2 and G_3 . Near the dead centers the situation can also occur when the piston does not tilt and is pressed to one side of the cylinder.

Constraint force exerted on the link from the slider's side is parallel to x axis. If directions of the force and the axis coincide, contact point the link and the slider is B_1 , otherwise the contact point is B_2 .

The direction of frictional forces exerted at the cylinder and piston contact points is opposite to the direction of piston movement. The direction of frictional force exerted at the link and slider contact point coincides with the direction of slider movement.

Directions of the constraint forces exerted on the piston and the link at the contact points are unknown and have to be assumed. After the initial assumption is made, the equation of reciprocating motion of the piston in x direction, equilibrium equation of forces in y direction and that of the moment about O_s point can be obtained. Point O_s is the intersection point of the cylinder center line and y axis (Fig. 2). After solving the system of equations the assumption has to be verified.

Unknown constraint forces are found from a single system of equations which does satisfy all cases (i.e.

various possible contact points). In such system F_{gt1} and F_{gt2} are replaced with F_{GT1} , and F_{gn1} and F_{gn2} are replaced with F_{GN1} . If $F_{GN1} > 0$, contact point of the cylinder and the piston is G_1 , otherwise (if $F_{GN1} < 0$) the contact point is G_2 . Similarly the forces F_{gt3} and F_{gt4} are replaced with F_{GT2} , the forces F_{gn3} and F_{gn4} are replaced with F_{GN2} , the forces F_{bt1} and F_{bt2} are replaced with F_{BT} , and the forces F_{bn1} and F_{bn2} are replaced with F_{BN} .

Since it is considered that frictional state at the cylinder – piston pair and the link – slider pair is under the boundary lubrication, frictional forces F_{GT1} , F_{GT2} and F_{BT} at G_1 , G_2 , G_3 , G_4 , B_1 and B_2 points are subjected to Coulomb's law of friction

$$\left. \begin{aligned} F_{GT1} &= \delta_1 \delta_3 \mu_c F_{GN1}; & F_{GT2} &= \delta_1 \delta_4 \mu_c F_{GN2} \\ F_{BT} &= \delta_2 \delta_5 \mu_s F_{BN} \end{aligned} \right\} \quad (4)$$

where μ_c , μ_s are friction coefficients in the pairs cylinder – piston and link – slider respectively; Variables δ_1 , δ_2 , δ_3 , δ_4 and δ_5 are given by the following definitions

$$\left. \begin{aligned} \delta_1 &= \text{sgn}(-\dot{x}_p), & \delta_2 &= \text{sgn}(\dot{y}_s), & \delta_3 &= \text{sgn}(F_{GN1}) \\ \delta_4 &= \text{sgn}(F_{GN2}), & \delta_5 &= \text{sgn}(F_{BN}) \end{aligned} \right\} \quad (5)$$

$\text{sgn}(x)$ is the function, given by the following definition

$$\text{sgn}(x) = \begin{cases} 1 & \text{for } x \geq 0 \\ -1 & \text{for } x < 0 \end{cases} \quad (6)$$

Friction force in a fluid film between the cylinder and the piston is calculated according to Petroff law, which in our case can be expressed

$$F_{FG} = -\eta \pi D (L_c - R(1 - \cos \varphi)) \dot{x}_p / c_p \quad (7)$$

where c_p is radial clearance between the piston and the cylinder; η is dynamic viscosity of the lubricant.

Friction force in a fluid film between the slider and the link could be ignored due to higher clearance.

The equation of reciprocating motion of the piston and the equilibrium equation of forces in y direction are

$$\left. \begin{aligned} -F_g + \delta_1 \delta_3 \mu_c F_{GN1} + \delta_1 \delta_4 \mu_c F_{GN2} + F_{BN} + F_{FG} &= m_p \ddot{x}_p \\ F_{GN1} + F_{GN2} + \delta_2 \delta_5 \mu_s F_{BN} &= 0 \end{aligned} \right\} \quad (8)$$

Since $\delta_i^2 = 1$, the equilibrium of moments about O_s point is obtained in the following form

$$\begin{aligned} & -\delta_1 \mu_c F_{GN1} D/2 - F_{GN1} L_{st} - \delta_1 \mu_c F_{GN2} D/2 - \\ & - F_{GN2} (L_p - L_c + R(1 - \cos \varphi)) + \\ & + F_{BN} (e + R \sin \varphi) - \delta_2 \mu_s F_{BN} D_s/2 - m_p \ddot{x}_p e_{cl} = 0 \end{aligned} \quad (9)$$

The Eqs. (8) and (9) make the system of linear equations with F_{GN1} , F_{GN2} , and F_{BN} as arguments

$$[A] \times (F) = (B) \quad (10)$$

where $[A]$ is 3×3 matrix with the following elements

$$\begin{aligned} a_{11} &= \delta_1 \delta_3 \mu_c, & a_{12} &= \delta_1 \delta_4 \mu_c, & a_{13} &= 1 \\ a_{21} &= 1, & a_{22} &= 1, & a_{23} &= \delta_2 \delta_5 \mu_s \\ a_{31} &= -\delta_1 \mu_c D/2 - L_p \\ a_{32} &= -\delta_1 \mu_c D/2 - (L_p - L_c + R(1 - \cos\varphi)) \\ a_{33} &= e + R \sin\varphi - \delta_2 \mu_s D_s/2 \end{aligned}$$

Vectors (F) and (B) are given in the following forms

$$\begin{aligned} (F) &= (F_{GN1} \quad F_{GN2} \quad F_{BN})^T \\ (B) &= (F_g - F_{FG} + m_p \ddot{x}_p \quad 0 \quad m_p \ddot{x}_p e_{cl})^T \end{aligned}$$

The solution of the system can be obtained using Cramer's rule

$$F_{GN1} = |A_1|/|A|, \quad F_{GN2} = |A_2|/|A|, \quad F_{BN} = |A_3|/|A|, \quad (11)$$

where $|A|$ is the determinant of matrix $[A]$; $|A_1|$, $|A_2|$ and $|A_3|$ are the determinants of the matrixes obtained by replacing respectively the first, the second and the third columns of matrix $[A]$ with vector (B) . Table 1 shows the expressions of determinants $|A|$, $|A_1|$, $|A_2|$ and $|A_3|$.

Table 1

Determinants of the matrixes $[A]$, $[A_1]$, $[A_2]$ and $[A_3]$

Expression of the determinant	
$ A = \left\{ \left[\left((R(1 - \cos\varphi) + L_p - L_c) \delta_5 - D_s/2 \right) \delta_3 + (D_s/2 - L_p \delta_5) \delta_4 \right] \delta_2 \mu_s + (\delta_3 - \delta_4)(R \sin\varphi + e) \right\} \delta_1 \mu_c + \delta_2 \delta_5 \mu_c^2 \mu_s (\delta_3 - \delta_4) D/2 + R(\cos\varphi - 1) + L_c$	(12)
$ A_1 = \left\{ \left[(D/2 + e_{cl} \delta_4) \delta_1 \mu_c + L_p - L_c + R(1 - \cos\varphi) \right] \delta_5 - D_s/2 \right\} \delta_2 \mu_s + e + R \sin\varphi - e_{cl} \left\} m_p \ddot{x}_p + \left\{ \left[(\delta_1 \mu_c D/2 + L_p - L_c + R(1 - \cos\varphi)) \delta_5 - D_s/2 \right] \delta_2 \mu_s + e + R \sin\varphi \right\} (F_g - F_{FG})$	(13)
$ A_2 = \left\{ \left[D_s/2 - ((\delta_3 e_{cl} + D/2) \delta_1 \mu_c + L_p) \delta_5 \right] \delta_2 \mu_s + e_{cl} - e - R \sin\varphi \right\} m_p \ddot{x}_p + \left\{ \left[D_s/2 - (\delta_1 \mu_c D/2 + L_p) \delta_5 \right] \delta_2 \mu_s - e - R \sin\varphi \right\} (F_g - F_{FG})$	(14)
$ A_3 = (\delta_1 \mu_c e_{cl} (\delta_3 - \delta_4) + L_c + R(\cos\varphi - 1)) \ddot{x}_p m_p + (L_c + R(\cos\varphi - 1)) (F_g - F_{FG})$	(15)

3. Equation of motion of the slider

Fig. 3 shows the forces and the moments exerted on the slider. The constraint force F_{AN} and frictional force F_{AT} arise from the side of the link. These forces have the same values and opposite directions as forces F_{BN} and F_{BT} respectively, i.e. $F_{AN} = -F_{BN}$, $F_{AT} = -F_{BT}$. When $F_{BN} > 0$, forces F_{AN} and F_{AT} are exerted at point A_1 , otherwise the forces are exerted at point A_2 . Moment M_b is also exerted on the slider from the side of the link, which was not taken into account considering all the moments and forces exerted on the piston.

The bearing of the slider and the crankpin is lubricated by the oil pump, and frictional state of this bearing is evaluated by the theory of hydrodynamic lubrication. Frictional moment M_k and resultant F_k of the oil film force exerts on the inside surface of the slider (F_k is equal to the load of the bearing).

Coordinate x_s , velocity \dot{x}_s and acceleration \ddot{x}_s of the slider in the direction x are the same as these of the piston (Eq. (2)). Coordinate, velocity and acceleration of the slider in the direction y are given in Eq. (3).

Considering all forces exerted on the slider, the

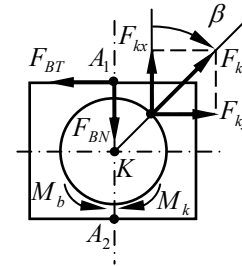

Fig. 3 Forces and moments on the slider

equilibrium equations in the directions x and y are

$$\begin{cases} -F_{BN} + F_{kx} - m_s \ddot{x}_s = 0 \\ -F_{BT} + F_{ky} - m_s \ddot{y}_s = 0 \end{cases} \quad (16)$$

where m_s is slider mass, F_{kx} , F_{ky} are oil film forces in the directions x and y . Since $F_{BT} = \delta_2 \delta_5 \mu_s F_{BN}$, the final forms of the equations are

$$\begin{cases} F_{kx} = F_{BN} + m_s \ddot{x}_s \\ F_{ky} = \delta_2 \delta_5 \mu_s F_{BN} + m_s \ddot{y}_s \end{cases} \quad (17)$$

The oil film force F_k and angle β are

$$F_k = \sqrt{F_{kx}^2 + F_{ky}^2}, \quad \beta = \arctg(F_{ky}/F_{kx}). \quad (18)$$

4. Equation of motion of the crankshaft

Before equations of motion of crankshaft can be derived, we have to make a choice between two-dimensional and three-dimensional model. Two-dimensional model is correct if the bearings are spaced symmetrically relatively to the cylinder. Such approach is often used for rotary compressors simulation as [2, 3]. It would be still acceptable for describing design with additional support (bearing) on the opposite side relatively to the cylinder, as in simulation of older designs of reciprocating connecting rod driven compressors [4]. In our case, however, such support is not used, and the crankshaft is under the cantilever load. The same scheme without additional support is used in the modern designs of connecting rod driven compressors. For such scheme the three-dimensional model is preferable.

Another question for consideration is which equation to choose for the calculation of friction coefficients in bearings. In [2] the friction coefficient for unloaded bearing is used, calculated according to Petroff law

$$\mu = \pi\eta\omega/(p\psi) \quad (19)$$

where η is dynamic viscosity of the lubricant; ω is angular velocity of sliding (in our case $\omega = \dot{\phi}$); ψ is relative clearance of the bearing, $\psi = c/r$ (where c is radial clearance of the bearing, i.e. difference between the radii of bush and shaft, r is the radius of the shaft); $p = F/(ld)$ is unit pressure in the bearing; l, d are respectively length and diameter of the bearing.

In our case, however, the bearings are heavily loaded and Eq. (19) equation is hardly acceptable. One possible approach would be to use an equation, which does not take into account eccentricity in the bearings, for example the following one

$$\mu = \pi\eta\omega/(p\psi) + 0.55\psi(l/d)^m \quad (20)$$

where $m = 1.5$ for $l < d$ and $m = 1$ for $l > d$.

Another approach is to use an equation, in which eccentricity is taken into account, e.g. the following

$$\mu = \eta\omega/(p\psi) \times \Phi_T \quad (21)$$

where Φ_T dimensionless coefficient of friction in fluid film. The coefficient is a function of the l/d ratio and of the position of the shaft in the bush. If misalignment is not taken into account, the position is defined by eccentricity ratio ε which is the ratio of eccentricity to clearance ($\varepsilon = e/c$); e is the eccentricity, i.e. distance from the centre of the bush to the centre of the shaft.

To find eccentricity ratio, dimensionless load capacity coefficient Φ_p must be calculated

$$\Phi_p = \psi^2/(\eta\omega) \times F/(ld) \quad (22)$$

Then eccentricity ratio can be found from the function $\Phi_p = f(l/d, \varepsilon)$. Such approach complicates the model, since at every step of integration we will have to solve a system of nonlinear equations (one additional equation for each bearing). The model can be improved even further if misalignment in the bearings is taken into account using advanced techniques and models described in [5].

Fig. 4 shows forces and moments exerted on the crankshaft (unbalanced inertia forces and moment of the forces are not shown on the figure).

The motor torque M_v is exerted on the crankshaft in counter clockwise direction respectively to the z axis.

Frictional moments in a bearings M_k (in crankpin bearing), M_R (in upper bearing) and M_S (in lower bearing) are exerted in counter clockwise direction and expressed as following

$$\left. \begin{aligned} M_k &= \mu_k F_k r_k \\ M_a &= \mu_a F_a r_r \\ M_b &= \mu_b F_b r_r \end{aligned} \right\} \quad (23)$$

where μ_k, μ_a, μ_b are friction coefficients in the bearings, calculated according Eq. (21); F_k, F_a, F_b are loads of the bearings; r_k, r_r are radii of crankpin and crankshaft.

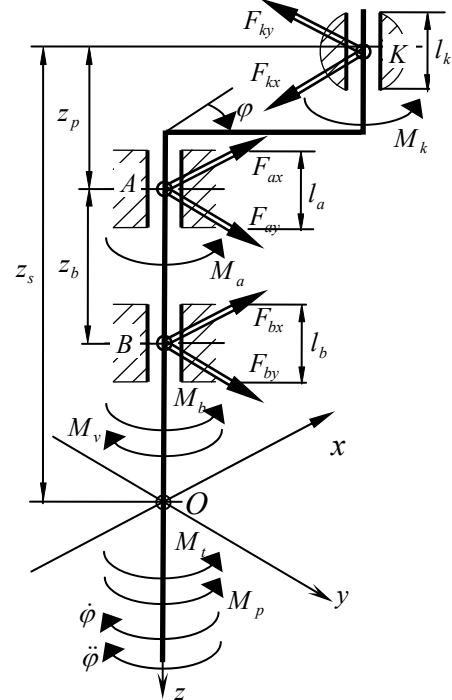

Fig. 4 Forces and moment exerted on the crankshaft (inertia forces not shown). z_b the distance from midline of the upper bearing to midline of the lower bearing; z_p the distance from midline of the upper bearing to midline of crankpin bearing in the direction of axis z ; z_s the distance from compressor's center of mass to the piston axis of symmetry in the direction of axis z

For the calculation of friction moment in thrust bearing M_t , the following equation was used

$$M_t = 2/3 \mu_t F_t \times (R_t^3 - r_t^3) / (R_t^2 - r_t^2) \quad (24)$$

where μ_t is friction coefficient in the bearing; R_t , r_t are outer and inner radii of the bearing, F_t is load of the bearing (equal to total weight of crankshaft with rotor).

According to experiments 3 to 3.8 W were dissipated for friction in the thrust bearing, which gives friction coefficient of $\mu_t = 0.086 - 0.108$. If surfaces were not parallel, friction power increased up to 6.8 W ($\mu_t = 0.194$). The results correspond with reference data for boundary lubrication in a cast-iron friction pair ($\mu = 0.1 - 0.2$).

Friction moment in an oil pump M_p assumed constant (friction power assumed equal to 2.5 W).

The projections of inertia forces from rotation of the crankshaft (with rotor) on the axes x and y are

$$\left. \begin{aligned} P_{Rx} &= -m_r e_{cr} (\dot{\varphi}^2 \cos \varphi + \ddot{\varphi} \sin \varphi) \\ P_{Ry} &= -m_r e_{cr} (\dot{\varphi}^2 \sin \varphi - \ddot{\varphi} \cos \varphi) \end{aligned} \right\} \quad (25)$$

where m_r is mass of crankshaft with the rotor; e_{cr} is distance from the rotation axis z to the center of mass of the crankshaft with rotor in the direction opposite to the crankpin (Fig. 5).

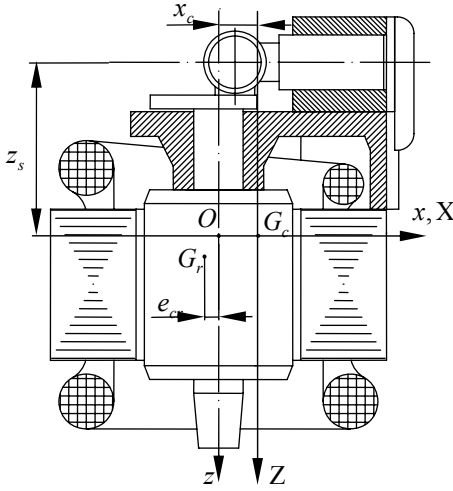

Fig. 5 Coordinate and variables. G_c compressors center of mass (without shell); G_r center of mass of the crankshaft with rotor; z_s the distance from the mass center of the compressor to symmetry axis of the piston in the direction of axis z ; x_c the distance from rotation axis z to the mass center of the compressor e_{cr} the distance from rotation axis z to the mass center of the crankshaft with rotor

Moments of the inertia forces with respect to axes x , y and z are, respectively

$$\left. \begin{aligned} M_{Rx} &= -J_{x'z} (\dot{\varphi}^2 \sin \varphi - \ddot{\varphi} \cos \varphi) \\ M_{Ry} &= J_{x'z} (\dot{\varphi}^2 \cos \varphi + \ddot{\varphi} \sin \varphi) \\ M_{Rz} &= -J_z \ddot{\varphi} \end{aligned} \right\} \quad (26)$$

where $J_{x'z}$ is product of inertia of the crankshaft with rotor and counterweight with respect to x' , z axes (axis x' is rotating with the crankshaft, and coincides with axis x when the piston is at the upper dead center); J_z inertia moment of the crankshaft with rotor with respect to z axis.

Considering all forces exerted on the crankshaft, equilibrium equations of the forces in x and y directions are given in the following forms

$$\left. \begin{aligned} F_{ax} + F_{bx} - F_{kx} + P_{Rx} &= 0 \\ F_{ay} + F_{by} - F_{ky} + P_{Ry} &= 0 \end{aligned} \right\} \quad (27)$$

where F_{ax} , F_{ay} , F_{bx} , F_{by} are components of reactions at supports F_a and F_b . The reactions are equal to the load of bearings.

The equilibrium equations of moments relatively to axes x and y and the equation of rotational motion relatively axis z are

$$\left. \begin{aligned} -F_{ky} z_s + F_{ay} (z_s - z_p) + F_{by} (z_s - z_p - z_b) + M_{Rx} &= 0 \\ F_{kx} z_s + F_{ax} (z_s - z_p) + F_{bx} (z_s - z_p - z_b) + M_{Ry} &= 0 \end{aligned} \right\} \quad (28)$$

$$M_v - M_k - M_a - M_b - M_t - M_p +$$

$$+ F_{kx} R \sin \varphi - F_{ky} R \cos \varphi - J_z \ddot{\varphi} = 0 \quad (29)$$

The components of reactions at supports F_{ax} , F_{ay} , F_{bx} , F_{by} can be found from the following systems of linear equations

$$\left. \begin{aligned} F_{ax} + F_{bx} &= -P_{Rx} + F_{kx} \\ -F_{ax} (z_s - z_p) - F_{bx} (z_s - z_p - z_b) &= -M_{Ry} + F_{kx} z_s \\ F_{ay} + F_{by} &= -P_{Ry} + F_{ky} \\ F_{ay} (z_s - z_p) + F_{by} (z_s - z_p - z_b) &= -M_{Rx} + F_{ky} z_s \end{aligned} \right\} \quad (30)$$

Expressions obtained after solving the systems are given in the Table 2.

In the expressions γ_1 , γ_2 and γ_3 are functions, defined by the following equations

$$\left. \begin{aligned} \gamma_1 &= 1/|A| \\ \gamma_2 &= \delta_1 \mu_c e_{cl} (\delta_3 - \delta_4) + L_c + R (\cos \varphi - 1) \\ \gamma_3 &= L_c + R (\cos \varphi - 1) \end{aligned} \right\} \quad (31)$$

The reactions at supports are

$$F_a = \sqrt{F_{ax}^2 + F_{ay}^2}; \quad F_b = \sqrt{F_{bx}^2 + F_{by}^2} \quad (32)$$

Frictional moments in the bearings M_a and M_b depend on the reactions, and are given by Eq. (23). The moments are part of the Eq. (29), from which the equation of rotating motion of the crankshaft is obtained. For numerical solution the equation should be presented in the following form $\ddot{\varphi} = f(\varphi, \dot{\varphi}, t)$. However, this is not possible even after significant simplification, and the equation is

Components of reactions at supports F_{ax} , F_{ay} , F_{bx} and F_{by}

$F_{ax} = \left\{ \left(\ddot{\phi} \sin \varphi + \dot{\phi}^2 \cos \varphi \right) \left[J_{x'z} + m_r e_{cr} (z_p - z_s + z_b) - R(z_p + z_b) (\gamma_1 \gamma_2 m_p + m_s) \right] + \gamma_1 \gamma_3 (F_g - F_{FG}) (z_p + z_b) \right\} / z_b$
$F_{bx} = - \left\{ \left(\ddot{\phi} \sin \varphi + \dot{\phi}^2 \cos \varphi \right) \left[J_{x'z} + m_r e_{cr} (z_p - z_s) - R z_p (\gamma_1 \gamma_2 m_p + m_s) \right] + \gamma_1 \gamma_3 z_p (F_g - F_{FG}) \right\} / z_b$
$F_{ay} = - \left\{ \left(\ddot{\phi} \cos \varphi - \dot{\phi}^2 \sin \varphi \right) \left[J_{x'z} + m_r e_{cr} (z_p - z_s + z_b) - R(z_p + z_b) m_s \right] + \left(\ddot{\phi} \sin \varphi + \dot{\phi}^2 \cos \varphi \right) \delta_2 \delta_5 \mu_s \gamma_1 \gamma_2 R (z_p + z_b) m_p - \delta_2 \delta_5 \mu_s \gamma_1 \gamma_3 (z_p + z_b) (F_g - F_{FG}) \right\} \frac{1}{z_b}$
$F_{by} = - \left\{ \left(\ddot{\phi} \cos \varphi - \dot{\phi}^2 \sin \varphi \right) \left[-J_{x'z} - m_r e_{cr} (z_p - z_s) + R z_p m_s \right] - \left(\ddot{\phi} \sin \varphi + \dot{\phi}^2 \cos \varphi \right) \delta_2 \delta_5 \mu_s \gamma_1 \gamma_2 R z_p m_p + \delta_2 \delta_5 \mu_s \gamma_1 \gamma_3 z_p (F_g - F_{FG}) \right\} \frac{1}{z_b}$

presented as $\ddot{\phi} = f(\ddot{\phi}, \dot{\phi}, \phi, t)$. Therefore the special algorithm for numerical integrating of differential equation must be developed.

In the Eq. (29) the terms with F_{kx} and F_{ky} contain inertia terms caused by reciprocating motion of the piston. Deriving the inertia terms, we can obtain that

$$F_{kx} R \sin \varphi - F_{ky} R \cos \varphi = -\gamma_4 \ddot{\phi} - \gamma_5 \dot{\phi}^2 - \gamma_6 (F_g - F_{FG}) \quad (33)$$

where functions γ_4 , γ_5 and γ_6 are defined as follows

$$\left. \begin{aligned} \gamma_4 &= -R^2 \left[\gamma_1 \gamma_2 m_p (0.5 \delta_2 \delta_5 \mu_s \sin 2\varphi - \sin^2 \varphi) - m_s \right] \\ \gamma_5 &= R^2 \gamma_1 \gamma_2 m_p (0.5 \sin 2\varphi - \cos^2 \varphi \delta_2 \delta_5 \mu_s) \\ \gamma_6 &= -R \gamma_1 \gamma_3 (\sin \varphi - \cos \varphi \delta_2 \delta_5 \mu_s) \end{aligned} \right\} \quad (34)$$

By making use of Eq. (33), from the equilibrium of moments Eq. (29) the equation of rotating motion of the crankshaft is obtained by the following form

$$\ddot{\phi} = -(\gamma_4 + I_z)^{-1} \left[\gamma_5 \dot{\phi}^2 - M_v + M_k + M_a + M_b + M_s + M_t + \gamma_6 (F_g - F_{FG}) \right] \quad (35)$$

The equation can be used for the evaluation of unbalanced inertia forces, losses due to friction and vibrations of the slider-link driven compressor.

5. Unbalanced inertia forces and equations of vibration

To examine the compressors vibrations all forces and moments exerted on the cylinder block and the crank journal have to be clarified. Arranging the total of all forces and moments, resultant force and moment are derived in forms of unbalanced inertia forces.

The projections of inertia forces from rotation of the crankshaft (with rotor) on the axes x and y are expressed as Eqs. (25), and moments of the forces with respect to axes x , y and z are expressed as Eqs. (26).

Inertia force from motion of the piston in the direction x can be expressed

$$P_{Px} = -m_p \ddot{x}_p = m_p R (\dot{\phi}^2 \cos \varphi + \ddot{\phi} \sin \varphi) \quad (36)$$

Moments of the force with respect to axes y and

z are

$$\left. \begin{aligned} M_{Py} &= m_p \ddot{x}_p z_s = -m_p R z_s (\dot{\phi}^2 \cos \varphi + \ddot{\phi} \sin \varphi) \\ M_{Pz} &= -m_p \ddot{x}_p (e - e_{cl}) = m_p R (e - e_{cl}) (\dot{\phi}^2 \cos \varphi + \ddot{\phi} \sin \varphi) \end{aligned} \right\} \quad (37)$$

Projections of inertia forces from movement of slider on axes x and y are

$$\left. \begin{aligned} P_{Sx} &= -m_s \ddot{x}_s = m_s R (\dot{\phi}^2 \cos \varphi + \ddot{\phi} \sin \varphi) \\ P_{Sy} &= -m_s \ddot{y}_s = m_s R (\dot{\phi}^2 \sin \varphi - \ddot{\phi} \cos \varphi) \end{aligned} \right\} \quad (38)$$

Moments of the forces with respect to axes x , y and z are expressed as

$$\left. \begin{aligned} M_{Sx} &= -m_s \ddot{y}_s z_s = m_s R z_s (\dot{\phi}^2 \sin \varphi - \ddot{\phi} \cos \varphi) \\ M_{Sy} &= m_s \ddot{x}_s z_s = -m_s R z_s (\dot{\phi}^2 \cos \varphi + \ddot{\phi} \sin \varphi) \\ M_{Sz} &= -m_s R \ddot{\phi} \end{aligned} \right\} \quad (39)$$

Taking into account expressions (25), (26), (35)–(39), the components F_x , F_y , F_z of the resultant force at the coordinate center O and the moment M_x , M_y , M_z about x , y , z axis take the following forms of the unbalanced inertia forces

$$\left. \begin{aligned} F_x &= ((m_p + m_s)R - m_r e_{cr}) (\dot{\phi}^2 \cos \varphi + \ddot{\phi} \sin \varphi) \\ F_y &= (m_s R - m_r e_{cr}) (\dot{\phi}^2 \sin \varphi - \ddot{\phi} \cos \varphi) \\ F_z &= 0 \\ M_x &= (m_s R z_s - J_{x'z}) (\dot{\phi}^2 \sin \varphi - \ddot{\phi} \cos \varphi) \\ M_y &= (J_{x'z} - (m_p + m_s) R z_s) (\dot{\phi}^2 \cos \varphi + \ddot{\phi} \sin \varphi) \\ M_z &= -(J_z + m_s R) \ddot{\phi} + m_p R (e - e_{cl}) (\dot{\phi}^2 \cos \varphi + \ddot{\phi} \sin \varphi) \end{aligned} \right\} \quad (40)$$

The Eqs. (40) were derived for coordinate system with origin O on the axis z (rotation axis of crankshaft). To represent the compressor vibrations, X , Y , Z coordinate system is defined, in which the origin coincides with the compressor's mass centre G_c at rest and each axis is parallel to corresponding axis of x , y , z coordinate system. For the new coordinate system with the origin in G_c

and axes X , Y , Z components of the resultant force and the moment about axis X and Y have the same forms as Eqs. (40) for x , y , z coordinate system, i.e. $F_X = F_x$, $F_Y = F_y$, $F_Z = F_z$, $M_X = M_x$, $M_Y = M_y$. The moment about Z axis M_Z is

$$M_Z = M_z - x_c F_y \quad (41)$$

where M_z and F_y are moment and force, calculated according to Eqs. (40).

For X , Y , Z coordinate system vibrations of the compressor are subject to the following matrix equation:

$$[M][\ddot{X}] + [C][\dot{X}] + [S][X] = [F] \quad (42)$$

where $[X]$ is displacement matrix of mass center G_c ; $[M]$ is mass matrix; $[F]$ force matrix, composed of unbalanced inertia forces; $[C]$ is damping matrix, determined by viscosity coefficients; $[S]$ is stiffness matrix determined by spring constants of the suspension system.

$$\begin{aligned} [X] &= [X_G \ Y_G \ Z_G \ \Theta_X \ \Theta_Y \ \Theta_Z]^T \\ [F] &= [F_x \ F_y \ F_z \ M_x \ M_y \ M_z]^T \\ [M] &= \begin{bmatrix} M & \cdot & \cdot & \cdot & \cdot & 0 \\ \cdot & M & \cdot & \cdot & \cdot & \cdot \\ \cdot & \cdot & M & \cdot & \cdot & \cdot \\ \cdot & \cdot & \cdot & J_X & \cdot & \cdot \\ \cdot & \cdot & \cdot & \cdot & J_Y & \cdot \\ 0 & \cdot & \cdot & \cdot & \cdot & J_Z \end{bmatrix} \end{aligned}$$

where X_G , Y_G , Z_G are displacements of G_c in the directions of X , Y and Z ; Θ_X , Θ_Y , Θ_Z are angles of rotation of the compressor about X , Y and Z ; M is compressor mass; J_X , J_Y , J_Z are inertia moments of the compressor with respect to X , Y and Z .

Determination of $[C]$ and $[S]$ is complicated. On the other hand, when natural frequency of vibration system is fairly small compared with the crankshaft speed, solution of the vibration Eq. (42) can be approximately obtained by the following equation

$$[\ddot{X}] = [M]^{-1}[F] \quad (43)$$

6. Conclusion

The described mathematical model is targeted for the evaluation and minimization of losses due to friction and compressor vibrations. The model could be useful tool for designers at early stage of compressor development.

References

1. **Vaitkus, L.** Research and Simulation of Valve System of Hermetic Refrigerating Compressor. Doctoral thesis.

-Kaunas, 1998.-108p. (in Lithuanian).

2. **Imaichi, K., Fukushima, M., Muramatsu, S., Ishii, N.** Vibration analysis of rotary compressors.-Proc. of the Int. Compressors Engineering Conf. at Purdue. - USA, 1984, p.275-282.
3. **Ooi, K.T., Wong, T.N.** A computer simulation of a rotary compressor for household refrigerators. -Applied thermal engineering, 1997, v.17, No.1, p.65-78.
4. **Rigola, J.S.** Numerical Simulation and Experimental Validation of Hermetic Reciprocating Compressors. - Integration in Vapour Compression Refrigerating Systems. Doctoral thesis.-Terrassa, 2002.-109p.
5. **Stachowiak G., Batchelor A.** Engineering Tribology.- Butterworth-Heinemann, 2005.-832p.

V. Dagilis, L. Vaitkus, D. Kirejchick

KULISINIS KOMPRESORIUS (I). MATEMATINIS MODELIS

R e z i u m ė

Aprašytas matematinis modelis yra skirtas kulisiniam kompresoriui optimizuoti, t. y. parinkti tokiems geometriniam parametrams (stūmoklio eigai ir skersmens santykiui, stūmoklio ekscentricitetui, tarpeliui tarp stūmoklio ir cilindro ir t. t.), kurie užtikrintų didžiausią efektyvumą.

V. Dagilis, L. Vaitkus, D. Kirejchick

SLIDER-LINK DRIVEN COMPRESSOR (I). MATHEMATICAL MODEL

S u m m a r y

The presented mathematical model is targeted for the optimization of slider-link driven compressor, i.e. for the selection of such geometrical parameters (piston stroke to diameter ratio, piston eccentricity, clearance between the piston and the cylinder, etc.), which will ensure the highest efficiency.

В. Дагилис, Л. Вайткус, Д. Кирейчик

КУЛИСНЫЙ КОМПРЕССОР (I). МАТЕМАТИЧЕСКАЯ МОДЕЛЬ

Р е з ю м е

Представленная математическая модель предназначена для оптимизации кулисного компрессора, т.е. для подбора таких геометрических параметров (отношения хода поршня к диаметру, эксцентриситета поршня, зазора между поршнем и цилиндром и т. д.), которые обеспечивают высшую эффективность.

Received September 04, 2006

DOI: 10.5755/j02.mech.14775