

# Breaking down the manufacturing process of sheet metal products into features

**M. Lohtander\***, **M. Lanz\*\***, **J. Varis\*\*\***, **M. Ollikainen\*\*\*\***

\**Lappeenranta University of Technology, P.O. Box 20, FIN-53851 Lappeenranta, Finland, E-mail: lohtande@lut.fi*

\*\**Tampere University of Technology, P.O. Box 527, FIN-33101 Tampere, Finland, E-mail: minna.lanz@tut.fi*

\*\*\**Lappeenranta University of Technology, P.O. Box 20, FIN-53851 Lappeenranta, Finland, E-mail: juha.varis@lut.fi*

\*\*\*\**Lappeenranta University of Technology, P.O. Box 20, FIN-53851 Lappeenranta, Finland, E-mail: mikael.ollikainen@lut.fi*

## 1. Introduction

Computer-aided design (CAD) of sheet metal components is rather easy at present. However, the apparently easy design process can result problems in the manufacturing properties of sheet metal components. This is due to the fact that design software programmes have a number of automatic features that facilitate drawing a component, but that do not automatically improve its manufacturability. Consequently, one should always take into account the manufacturing technologies used, and consider the consequences of selecting a certain technology. This is why designers should have sufficient experience or guides to make the product as manufacturing friendly as possible.

Globalization changes the traditional concepts in the supplier-client relationship. In a traditional local operational model, where processes were often physically close to each other, manufacturing methods and their applicability could be defined flexibly depending on the situation. The feedback from one party to another was given immediately, and errors were easy to correct. The performance of production processes was known by the customer's representatives, and the processes were often developed in cooperation to achieve the best possible results, taking into account the special features of the end products. In a global distributed operational model, these synergy benefits rarely exist - if at all - and controlling the transition between the processes has become more difficult.

According to one estimate [1], only 20-40% of production was carried out in production plants owned by globally operating companies in 2005. For designers, this inevitably leads to a decrease in manufacturing know-how, and the possibilities and limitations involved in manufacturing cannot be taken into consideration in the design of new products.

## 2. Challenges in the design of sheet metal products

The main responsibility of detailed design is increasingly being shifted from manufacturers towards businesses specializing in design services. Designers employ systems such as CAD, CAM and CAE, which are very multidimensional and have high-level functionality. However, these systems cannot take into consideration the different aspects in manufacturing technologies, and their assessment is thus left to the designer. The key question is: how can the designer take into account or even know the sheet metal manufacturer's equipment, available tools and manufacturing resources, or make one and the same prod-

uct easy to manufacture with different equipment?

CAD, CAM and CAE programmes rarely allow real and extensive mutual information exchange. Usually when information is transferred from one system to another, some information is always lost. If, for instance, a CAD programme has set tolerance parameters for a certain hole, it is very likely that these parameters will not be transferred to another programme with the geometric model.

Currently, there are software solutions that can be applied to the design of any stage of product life cycle management (e.g. Dassault Systems), but the cost of a functional version, i.e. all of the functional parts, is approximately 100 000 - 300 000 dollars, and with average options the expenses may rise to a million dollars [2]. The software solutions are thus outside the price range of the majority of SMEs. In addition, information exchange outside the system is mainly limited to step and iges formats. In practice, this means that mere geometry is transferred from one system to another.

Regardless of the fact that more advanced CAD systems use feature information in internal communication, features cannot, with some exceptions, be transferred outside the system. Moreover, the internal feature recognition of the software solutions will not necessarily function if the transferred product or part is not modelled with the same software version.

Parallel design allows working simultaneously on product design and manufacturing. This is one of the basic ideas of the Design for Manufacture (DFM). The key question is, how can one designer cooperate with many manufacturers across possible language and culture barriers and with software that only transfers geometry? On the other hand, domestic actors have excellent possibilities to work in the spirit of DFM and with tools it provides. This national activity should somehow also be harnessed for distributed activities. DFM tools give designers many guidelines and instructions that are, however, in clear contradiction with real-world operational models. At least four of the basic DFM principles cannot be applied to practice in the distributed production of sheet metal products. These principles are:

- minimizing the different stages of production and work;
- verifying the suitability of the material for the manufacturing method in question;
- selecting a manufacturing method that requires minimal presetting and preparations;
- selecting the same manufacturing method for as many

parts as possible.

In distributed production, product parts can be manufactured with different methods because in different parts of the world the equipment, methods, practices and traditions are different. If the manufacturing methods differ, it is difficult, e.g. to choose one common and suitable raw material. When choosing a manufacturing method with minimum preparations, how can one be sure that the method is available globally? And when production should be launched simultaneously around the world, the implementation of the production system is especially challenging. Selecting the same production technology for different products is difficult because some countries may have similar products which have traditionally been manufactured in a different and equally functional way.

It is also possible that companies cannot, depending on the equipment or expertise, manufacture products in the preselected way, but must modify the process to better adapt to their working environment. Consequently, features that determine the process variants should be defined so that they are universal, for instance the tolerance requirement, surface roughness, etc. Thus, the equipment cannot be chosen directly.

### 2.1. Universally applicable design of a component

The problem above could be solved by developing a database for designers to use. The database should include information on different types of sheet metal, i.e. its features and their combinations. Under each feature, there should be a description of the possible manufacturing techniques. Correspondingly, combinations of the features should include the conditions under which they could be manufactured. In such cases, the designer could use the database to design a part in as universal a form as possible to allow cost-effective manufacturing with a variety of methods.

For example, this could be applied to punching round holes into sheet metal of carbon steel. For instance, a turret punch press can make a hole with a minimum diameter of 1.5 times the sheet thickness using multitool solutions. Nibbling should, however, be avoided. Fine-blanking technology allows punching considerably smaller holes in sheet metal of the same thickness. Also laser technology enables making very small holes in proportion to the sheet thickness.

Another example is the situation where a sheet metal part for outdoor use is made of hot galvanized steel. The product can be manufactured with a number of methods. If laser cutting is applied, a supplementary surface treatment stage - zinc coating of the cut surfaces - is required. In mechanical punching, cut edges do not need to be treated because protective zinc is impressed into the punched part.

A designer's guide could include points from the examples above, which would help to avoid the problems related with production technologies or recognise them early on. This would make the product easier and possibly less costly to manufacture because the designer would be able to take into consideration the manufacturability of different shapes with a variety of technologies already at the very beginning of his or her work.

### 2.2. Manufacturing features

A sheet metal part is usually composed of shapes: levels, bending, cutting, holes and forming. These have traditionally been called geometrical features. Also non-geometrical features can be considered [3]. These include, for example:

- colour;
- material;
- constraints;
- tolerances;
- surface roughness;
- mate;
- manufacturing method.

The manufacturing features of sheet metal have been researched, e.g. by Wang [4] who has studied sheet metal parts bending with a robotized bending machine. When designing the manufacturing process of a sheet metal product, one should take into account not only individual features and geometries, but also their combinations. The simplest combination of features may include two bends or a bend and a hole side by side.

### 2.3. Research objective

Shapes or features in sheet metal parts can be manufactured with a variety of technologies. The selection of a technology may, however, often have a deciding impact on the quality-related factors of the end product, as discussed, e.g. in section 2.1. Information on production technologies should be easily accessed and used by designers of sheet metal products so that it could be better applied to the design process.

The objective of this research is to divide the manufactured shapes and features into classes, such as bending, holes and forming, so that the designer could easily design the sheet metal product for manufacture. The purpose is to classify sheet metal shapes and features so that each one would correspond to a limited number of manufacturing technologies or other points related to manufacturing.

## 3. Manufacturing features of a sheet metal product

Products can be classified according to geometrical, assembly [3], manufacturing and other features. Manufacturing features are shapes generated with a particular sheet metal production method, or characteristics of the product that demand certain manufacturing measures [5]. These features are different from used design features.

Manufacturing features also include the most common shapes in sheet metal parts, such as bending, marking and threads, as well as characteristics, such as size and material. The following sections deal with the features in Fig. 1. The classification was created at Lappeenranta University of Technology during the project C\_DFMA (Conceptual Design for Manufacturing and Assembly), funded by Tekes – the Finnish Funding Agency for Technology and Innovation.

Manufacturing features to a certain extent are related to physical measurements and geometry of a part, and also to the required characteristics of a sheet metal product, such as lightening, perpendicularity, alignment, and similar features such as small holes which need different manufac-

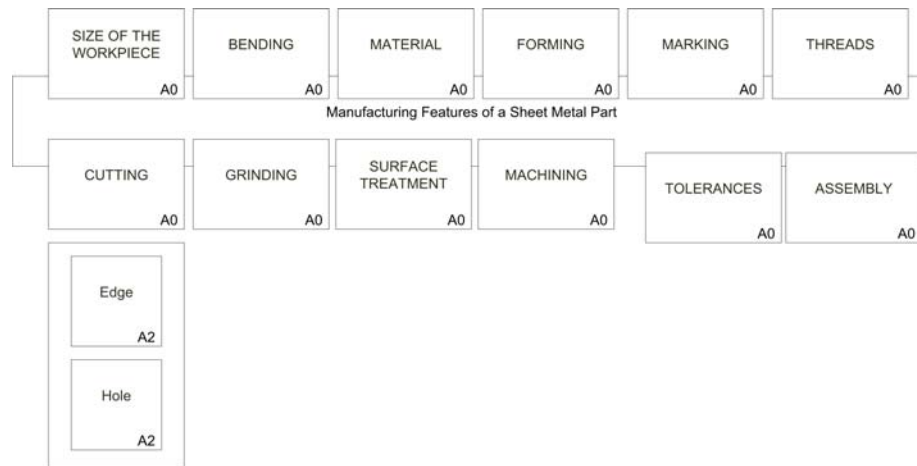

Fig. 1 Classification of the manufacturing features of sheet metal products and tolerances

turing technologies.

In this study, sheet metal features have been classified directly according to the manufacturing features. The first and the essential feature class is *dimensions and mass of the part*. The size of a part is mentioned as a separate class because its impact on the choice of manufacturing equipment is very significant. Manufacturing of very small or very large parts with a regular turret punch press is very difficult and in some cases even impossible.

*Bending* is a separate class because it requires its own machines and equipment. There are many different types of bending, and it also affects other features and the quality of the end product.

*Material* is also a separate class because, e.g. the laser cutting of glossy materials is more demanding than that of materials that easily absorb laser. Also the availability and strength of materials justify the formation of this separate class. Material is a combination of nongeometric features, such as strength, price, mass and light absorption.

*Forming* can be classified as a feature in two ways: as a process of its own or a sub-process, or as small and large forming. Small forming can be made on equipment or machine specifically not made for forming, such as a punching machine. Large forming is made on equipment designed specifically for forming.

In the *forming* class, the difficult point is recognising the feature. One should be able to pinpoint individual characteristics which reveal that the feature in question is, indeed, forming. For example, an updraft around a hole is such a characteristic. The manufacturing process should thus be able to identify from the process database geometric or nongeometric features or feature combinations that indicate forming, and that certain tools need to be applied.

*Marking* is a pattern imprinted on the surface of a sheet metal part. Marking can result from scratching the surface, from using a laser or from die-cutting. In addition, marking can be done with ink, adhesive labels and other technical tools, such as identifiers operating on radio frequency. Feature class identification from manufacturing drawing is rather simple. On the other hand, determining importance or priority of the marking class can be difficult because marking can be done, e.g. in connection with cutting or the final assembly.

*Threads* are essential part of a sheet metal product. Threads can be manufactured either with cutting or forming thread tools, by forming with a press or by installing separate threading parts. Threads are distinguished as

their own class because they can be manufactured in a number of ways, which partly overlap with, e.g. forming.

*Holes* are a sub-feature of *cutting*. This division is made because punching holes and *cutting* other *shapes* can, to a great extent, can be done by the same technologies and methods, such as punching, nibbling or laser cutting.

*Grinding* is normally carried out as a separate stage of work and with the equipment specially designed for this purpose. Therefore, it is considered an independent class. Grinding can be a sub-process or a process of its own. It can be a sub-process of, e.g. surface treatment, or its own process when aiming at a certain surface quality. The surface quality then becomes a feature that requires specific measures from the process. In the process description the considered surface can be obtained only by grinding.

*Surface treatment* gives presentable finish to the part and often prevents corrosion and wearing. This class can be divided into three main groups: pretreatment, actual surface treatment and finishing. It can also be divided into chemical and mechanical methods. Requirements can be set, e.g. with regard to coating thickness or glossiness. Then, for instance, coating thickness will require certain surface treatment methods.

Sheet metal parts may also require *machining* for example for embedding and countersinking. Machining is a separate process in manufacturing and thus a manufacturing feature of its own because it cannot be done with the same equipment as the other work stages. It is a combination of shapes, tolerances and materials.

*Tolerances* are not an actual manufacturing feature, but accuracy in manufacturing must always be taken into consideration in every manufacturing stage. Therefore, *tolerances* are placed among the feature classes. They thus compose their own *group of features*, which set certain requirements for manufacturing. There are different kinds of tolerances that require different measures from processes. Consequently, the tolerance group sets requirements for nearly all feature classes and, along with them, also for processes.

*Assembly* composes its own class of manufacturing features in this study. The assembly of sheet metal products can be further classified into assembly features and individual attributes. These features include, e.g. fasteners, such as nuts and screws, and clinching. Assembly features have been researched [3], [5] and [6].

In manufacturing and designing the manufactur-

ing process, one should take into account not only individual features, but also their combinations. By concentrating only on individual features and their manufacturing possibilities, feature combinations may be forgotten. These combinations may make a component difficult or even impossible to manufacture with certain methods [4].

### 3.1. Feature classes, characteristics, attributes and their manufacturing

The idea of features is based on the fact that each feature has certain characteristics that are defined in the design stage. These classes include geometric features, nongeometric features or individual attributes. In studies on the manufacturing features of sheet metal products, no distinction has been made between attributes and features. Attributes and features may, for example, include the points discussed in section 2.1.

In the design stage, each feature is given attributes in a predetermined format so that they can be interpreted according to the existing guidelines. This means that the designer adds requirements to the model for individual shapes or their combinations. Thus the designer does not need to decide the manufacturing method. For example, a round hole modelled by a designer is the feature “round hole”, which may include several attributes or sub-features. These attributes may be, e.g. surface quality of the hole or geometrical tolerances, such as circularity or straightness. The feature “round hole” searches the database for all of the methods with which the feature can be manufactured. Then the attributes or sub-features take the lead. For example, numerical value of the attribute “quality of the hole surface” may make it impossible to achieve the designed surface quality with certain manufacturing methods. Consequently, the database programme rejects these manufacturing methods and recommends only the methods that can be applied. The same is done for every attribute of the feature. Finally, the database screens the methods with which a feature with certain attributes can be manufactured. It is also possible that the database programme rejects all of the manufacturing methods. In such cases, the designer should reconsider the design and its attributes and their suitability for manufacturing. A designer who uses the system should have a basic knowledge of sheet metal products manufacturing technologies. Otherwise, the system should be prepared to be used as a guide. The designer could then search for information on sheet metal manufacturing from the system.

## 4. Case part

In this paper, we will use a fictitious sheet metal part as an example (Fig. 2). The part has 3 bends and 3 holes, which are countersunk (a cone-like embedding is made for the screw-head). The part is made from aluminium alloy of 2 mm thickness. With regard to the material, the part is a regular, uncoated sheet metal product.

### 4.1. Blanks and manufacturing volumes

In this section and the following ones, manufacturing of the case part is classified into manufacturing features. The very first stage, which is not indicated in the figures, is selection of the blank. The selection of the blank depends greatly on the series and batch size of the product.

These factors, in turn, have a significant effect on the selection of manufacturing method. The blank can be a sheet or a suitable piece cut from a reel.

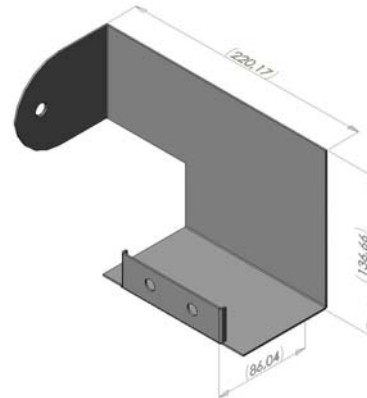

Fig. 2 The model part used in this study

If manufacturing volume is only a few hundred or thousand copies at most, the manufacturing method is much different from a batch of 100 000. In smaller volumes, it is more profitable to manufacture a sheet metal product such as our model by cutting, punching and bending each feature of the product in separate work stages. In large manufacturing volumes, the aim is usually to make the product in as few stages as possible. In practice, this means that cutting, punching and forming tool is needed in one machine. Practical manufacturing methods for the model part could include press and forming tools, or the fine-blanking method.

In the following sections, we assume that several thousand copies of the part will be made. Based on this assumption, the use of so-called hard tooling is excluded from manufacturing.

### 4.2. Cutting shapes

Cutting shapes can be carried out for the model part with mechanical or thermal methods. If the part is cut with thermal methods, such as laser or plasma, the screw-heads must be embedded and the part bent. If mechanical methods are applied, cutting can in most cases be combined with countersinking and bending.

Fig. 3 presents manufacturing by cutting and its dependencies on other feature classes and individual manufacturing technologies. Fig. 3 includes the feature classes of Fig. 1 and also the subdivision of the classes. Each sub-class is divided further into smaller entities. In the following section, we will discuss the features and the related attributes involved in the class “cutting” based on section 3.1. and Fig. 1.

Cutting shapes is included in the feature class “cutting” (Fig. 3). In cutting shapes, one must take into account size of the part (feature class), the material (feature class), surface treatment (feature class) and tolerances (feature group). From these categories, the database application searches for individual features that affect the choice of the process following the example in section 3.1. For the model part, for example the class “material” includes the sub-class “aluminium”. The feature “aluminium” includes, for instance, the individual nongeometrical feature or attribute “absorption”, which determines certain properties in, e.g. laser cutting. If absorption of the part is

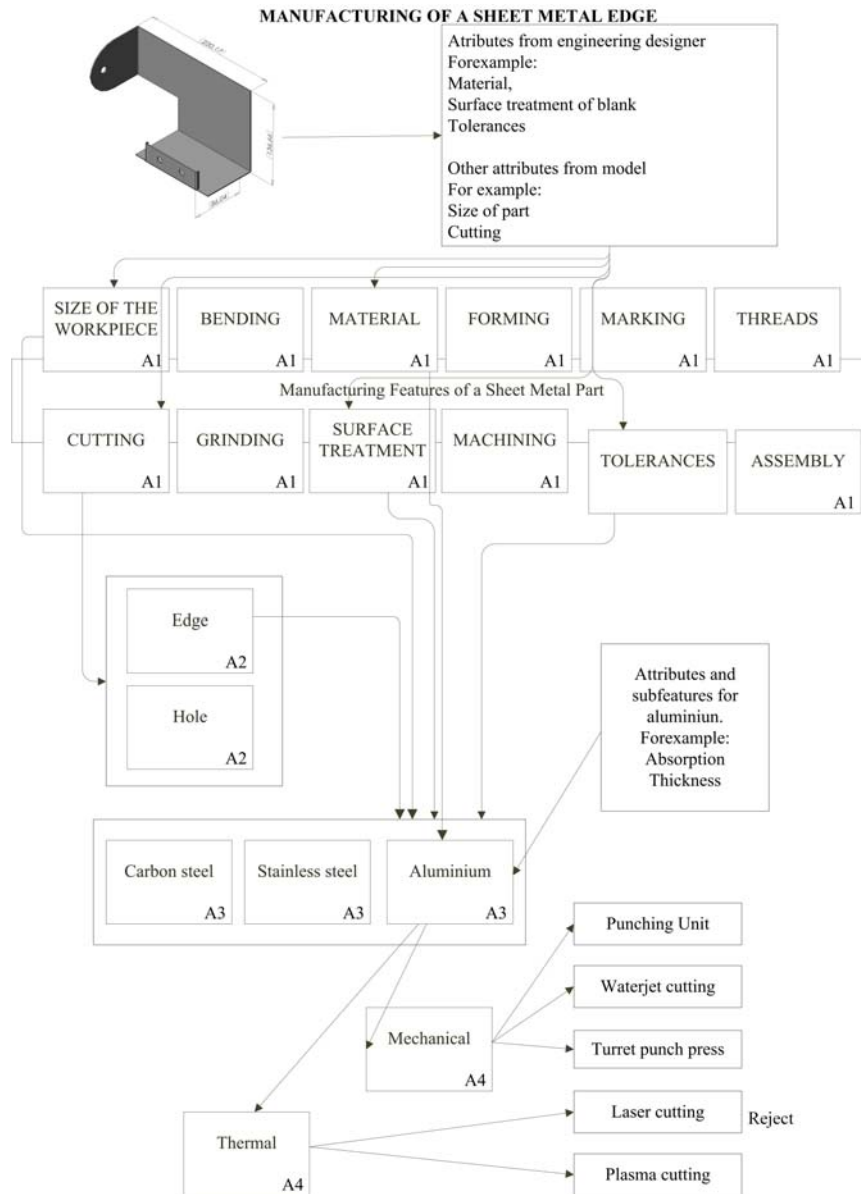

Fig. 3 Manufacturing technology feature classes and features related to cutting shapes

low for a given laser wavelength, the database rejects laser cutting attribute or sub-feature based on “low absorption”. This sub-feature or attribute is presented in the description of aluminium.

#### 4.3. Manufacturing holes

Punching holes in a sheet metal product seems a very simple task. From technical point of view this is the case, but decisions involving manufacturing technology applied can be difficult to make. Size of the hole in proportion to the material thickness has significant impact on the choice of technology. Likewise, tolerance requirements have an effect on the technology with which the desired accuracy can be achieved.

In manufacturing holes, just as in cutting edges, the effect of tolerances and surface treatment must be taken into consideration. Thermal methods may damage the coating, which may then need to be repaired. Cutting and punching holes mechanically reduces the risk of surface damaging.

When holes are made close to a bend, one should

make sure that the hole maintains its shape. The minimum distance between the hole and the bend or the part edge can be calculated, e.g. according to the communication 7/76 of the Federation of Finnish Metal, Engineering and Electro-technical Industries.

Fig. 4 shows how the feature “hole” is manufactured. Fig. 4 is derived from Fig. 1 by adding manufacturing features of holes and the relations between them. Punching a hole is included in the feature class “cutting”. In punching a hole, one must take into account size of the part (feature class), the material (feature class), surface treatment (feature class) and tolerances (feature group), i.e. the same categories as in cutting shapes. In addition, one must take into consideration the feature class “bending” because the hole may be near a bend. Individual features that affect the process choice are selected from the classes above. For the model part, in the feature class “bending” is given the attribute/sub-feature “hole near a bend”, which includes the feature combination “hole and bending”. The feature class “hole” contains the individual geometrical feature “radius”, and the feature class “bending” contains the feature “bending radius”. These two geometric features

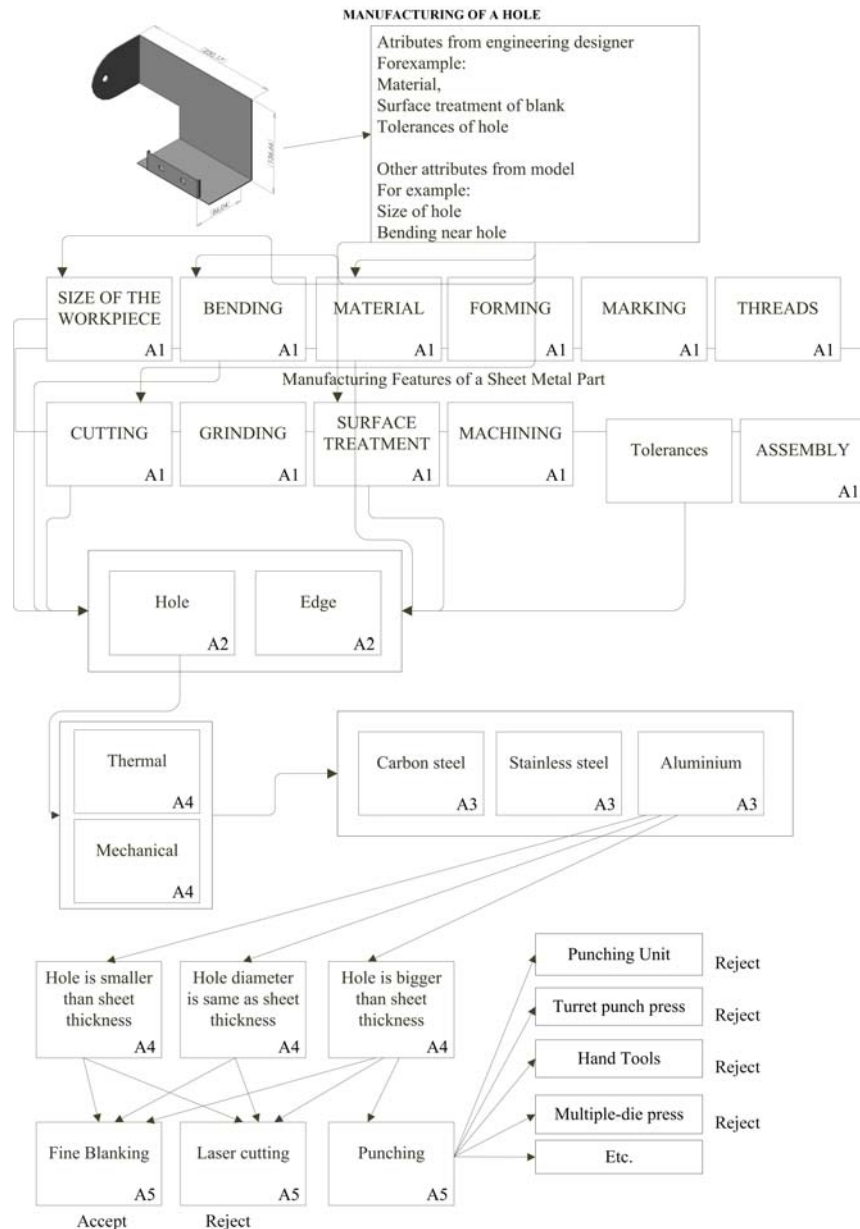

Fig. 4 Feature classes, features and available methods in manufacturing a hole

(radius and bending radius) determine the minimum distance of the hole from the bend, rendering the use of certain manufacturing technologies or tools impossible. In such cases, the database application searches for every possible method with which the hole and bending could be made. Then the database classifies the manufacturing technologies and rejects unsuitable methods. Rejection could be based on manufacturing method or process, or on individual manufacturing technology. In our model part, a hole can be made next to a bend by fine-blanking method. The designer can then establish the profitability of product manufacturing method.

#### 4.4. Countersinking

Countersinking, or making an embedding around a hole, can be carried out with several techniques. It can be combined with punching, or made by forming or machining. If the material is coated, the countersunk sections must be surface-treated again. Fig. 5 shows the tree of manufacturing features of countersinking. The idea is the same as in Fig. 3 and 4. The feature “countersinking” determines

first the feature classes “material”, “machining” and “surface treatment”. From these classes, the database searches for the features related to countersinking. By combining features and studying restrictions, we can define the processes with which the product can be manufactured with one of the technologies described in the previous sections.

#### 4.5. Bending

Bending is often quite a demanding stage of sheet metal product manufacturing. Designers aim to incorporate as many properties or functions into one part as possible. This may lead to complex bends that are difficult to manufacture.

Bending can be carried out with many methods, depending on the size. A punching machine can bend small and flat shapes, such as hinges. Larger bends need their own equipment, such as automatic panel bender or bending machine. Bending machines have many restrictions for example with regard to the size, mass and dimensions of a part. If a part is designed for robotized bending, problems may occur if manufacturing must be transferred to, e.g. an

## COUNTERSINKING

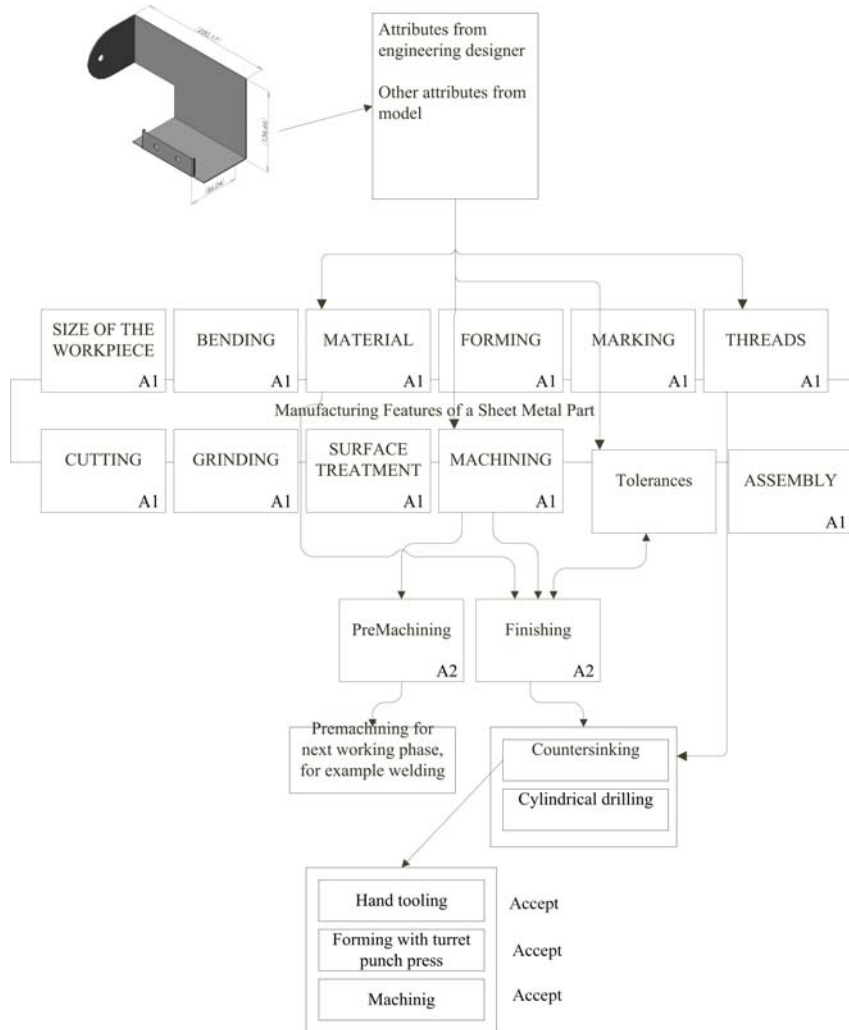

Fig. 5 Tree of the manufacturing features of countersinking

automatic panel bender. The part may be impossible to manufacture with a technology other than the designed one. In practice, this means that a new manufacturer must be found for that particular manufacturing stage or perhaps even the entire product. This, of course, brings unnecessary expenses.

Fig. 6 presents the choice of a manufacturing technology for bending based on feature classes. In essence, bending is similar to other feature classes. In this example, we assume that the press brake is rejected because the shortest bends are too small for the width of v-opening of the lower tool.

#### 4.6. Values of feature classes

A part may include features which must be manufactured before others depending on process technology. An example of such a feature is countersinking, which must be carried out before bending. The value of a feature class refers to the fact that features must be done in a certain order. For instance, cutting is usually done before bending, and bending before surface treatment. Individual features must, however, take precedence over feature classes. For example, the class “marking” includes individual features which may be of the same value as the class “cutting”. This is because marking can be performed in

connection with punching holes or assembly. The order in which feature classes, features, attributes and feature combinations are performed must be defined in the database based on practical processes.

#### 4.7. Forming

If manufacturing volume of a part rises to tens of thousands, a viable alternative would be to manufacture the part by forming, i.e. with so-called hard tooling. Also in such cases, there are several manufacturing technologies from which to choose. Depending on dimensional tolerances of the part, for example presses or the fine-blanking method can be applied. The database cannot give a direct solution to this problem because of its technical nature. If cost accounting were built into the database, it would also allow the direct comparison of cost factors.

In forming, manufacturing features can remain the same (Fig. 1) because the shapes made to the part remain the same. Nevertheless, the process parameters determined by the features in forming differ from those described in this paper even if the features themselves were the same.

By using press technology, several shapes can be made in one work stage. The shapes made can be called a group of features because most of the general design rules and principles applied in sheet metal design also are ap-

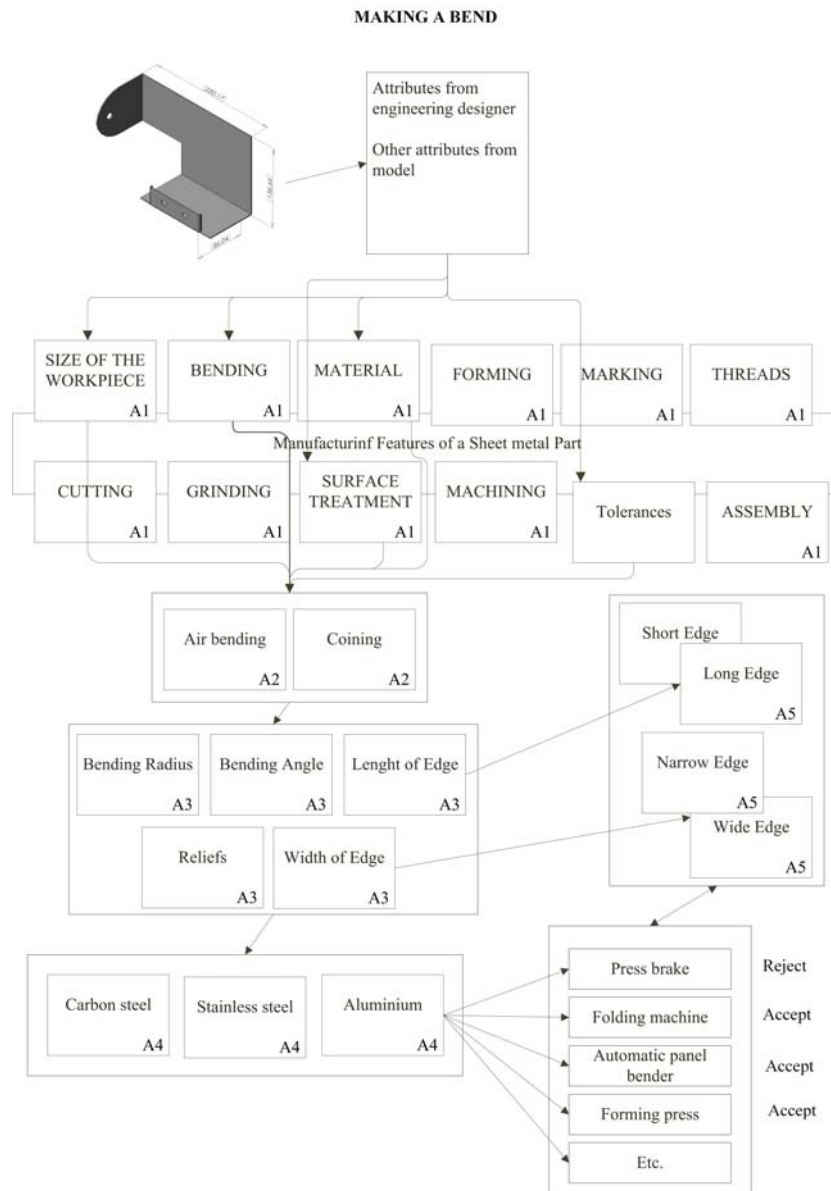

Fig. 6 Bending a sheet metal part is seemingly easy. Bending can, however, be performed in a number of ways. In all of the alternative methods, the previous and subsequent stages must be taken into consideration

plied to forming. Forming also allows to manufacture feature combinations which would be difficult to implement with other technologies

## 5. Conclusions and discussions

From the simple observation that behind each shape of a sheet metal product lies a restricted group of machines, we can deduce that sheet metal shapes can be classified into manufacturing features and feature classes. Thus, each shape corresponds to a feature class or feature. By preparing rules and restrictions for the feature classes and features, the design of sheet metal products can be made more manufacturing friendly. Each feature class corresponds to a limited number of processes in production. Thus the requirements set by the features and feature classes are concrete, and the requirements for processes set by the features can be met with existing equipment. In this study, we have drafted a model and used examples to describe its use as a design tool. The model's sheet metal shapes are composed of manufacturing features, which allow the division of shapes and properties into small units

based on manufacturing technology. Feature class thinking classifies shapes to correspond to the most common production stages. This study demonstrates with a model part that feature classes are functional. Each shape or feature in the model part belongs to a feature class. The classes – with individual features and attributes – help to determine the appropriate manufacturing technology.

This research distinguishes tolerances as their own feature group, which is connected with every feature class. This depicts the situation in practice since manufacturing accuracy must be taken into account in every manufacturing stage, be it punching, bending, surface treatment or any other property included in the feature classes.

By collecting as much information as possible on sheet metal manufacturing into one database or programme and by classifying the information based on the feature classes, different production methods can be considered already in the design stage with reasonable efforts. The designer can thus enhance his or her know-how. In addition, production methods in the system can be updated individually for each company involved in order to keep the system up to date.

A designer of a sheet metal product needs no special manufacturing-related know-how to operate the database because it is already incorporated in the database. The designer must, however, know which technologies and processes are available in the manufacturing company in order to design the product so that it can be manufactured with them. The database application also allows to search for information on the possibilities and limitations of manufacturing technologies. This enables sheet metal product designer to enhance his or her know-how and design products that are easier to manufacture.

The feature classes presented in this study are applicable to sheet metal production that does not involve forming. Forming does not prevent the use of features, but the classification in this study cannot be directly applied to it.

## References

1. **Zhao, Z.** et al. Domain independent shell of DFM and its application to sheet metal forming and injection molding. -Computer Aided Design 37, 2005.
2. **CIMdata.** The benefits of digital manufacturing. An independent report on achieved benefits and return on investments with DELMIA solutions, 2003.-11p.
3. **Lanz, M.** et al. CAID&CD'05, Delft, Feature-based modelling and analysis for knowledge-intensive concurrent engineering in final assembly, 2005, p.560-561.
4. **Wang, Cheng-Hua,** et al. Design and manufacturing of sheet metal parts: Using features to aid process planning and resolve manufacturability problems. Robotics and Computer-Integrated Manufacturing, 1997, v.13, No3. The Robotics Institute Carnegie Mellon University. Pittsburgh, PA 15213, USA, p.281-294.
5. **van der Net, A.J.** Designing and Manufacturing Assemblies. Eindhoven University of Technology. -Doctoral Dissertation. ISBN 90-386-0780-6, 1998.-149p.
6. **van Holland, W.** Assembly Features In Modelling and Planning. Delft University of Technology, Holland. Doctoral Dissertation. ISBN 90-9011056-9.-165p.

M. Lohtander, M. Lanz, J. Varis, M. Ollikainen

## METALO LAKŠTO GAMINIŲ GAMYBOS PROCESO SKIRSTYMAS Į ELEMENTUS

### Reziumė

Gaminių iš metalo lakštų kompiuterizuotas projektavimas (CAD) dabar gerokai palengvėjo. Tačiau palyginti lengvas konstravimas gali sukelti problemų metalo lakštų gaminių gamyboje. Dėl šios priežasties konstruktorius visuomet turi žinoti taikomas gamybos technologijas ir pasirinkti tinkamiausias.

Šiame straipsnyje pateiktas metalo lakštų gaminių gamybos elementų klasifikavimas. Elemento klasė nusako specifinį gamybos ypatumą, pavyzdžiui, lankstymą. Ji aprašoma atributais ir forma, kurie toliau skirstomi į poklasių formas ir atributus. Forma ir atributai lemia elemento gamybos procesą. Kitaip sakant, elementai nusako tam tikrus gaminių gamybos procesus ir jų charakteristikas.

Naudojant sukurtą elementais pagrįstą duomenų bazę, gaminio konstruktoriui turėtų būti lengviau rasti

reikiamą informaciją, kaip pigiausiai pagaminti sukonstruotą gaminį.

M. Lohtander, M. Lanz, J. Varis, M. Ollikainen

## BREAKING DOWN THE MANUFACTURING PROCESS OF SHEET METAL PRODUCTS INTO FEATURES

### Summary

Computer-aided design (CAD) of sheet metal parts is considered rather easy at present. However, the apparently easy design process can result in the problems in manufacturing properties of sheet metal parts. Consequently, one should always take into account the manufacturing technologies used, and consider the consequences of selecting a certain technology.

In this study, manufacturing features of sheet metal products are divided into feature classes. A feature class describes specific manufacturing property of a sheet metal product, such as bending. A feature class comprises individual features and attributes, which are further divided into other features and attributes. Features and attributes together determine the process with which a product can be manufactured. In speaking manner, features invite certain processes and process parameters, that is, a feature tells the process how it should be manufactured.

Designing and implementing a feature-based database application would help designers to obtain information on different technologies that can be applied to product manufacture.

M. Лохтандер, М. Ланз, И. Варис, М. Олликаинен

## КЛАССИФИКАЦИЯ ПРОИЗВОДСТВЕННОГО ПРОЦЕССА ИЗДЕЛИЙ ИЗ СТАЛЬНОГО ЛИСТА НА ЭЛЕМЕНТЫ

### Резюме

Компьютерное проектирование изделий из стального листа теперь производится быстрее. Сравнительно легкое проектирование изделий из стального листа может создать проблемы в производстве. По этой причине конструктор всегда должен знать применяемые технологии и выбрать для данного случая.

В статье рассматривается классификация производственных элементов изделий из стального листа. Класс элемента описывает специфическое свойство производства, например, изгиб. Оно описывается атрибутами и формой, которые далее классифицируются на формы и атрибуты подкласс. Форма и атрибуты определяют производственный процесс элемента. Иными словами, элементы определяют процессы, их характеристики и правила, как они должны изготавливаться.

Использование и внедрение базы данных на основе исследованных элементов должно помочь конструктору изделия найти информацию, как с наименьшими затратами изготовить созданное новое изделие.

Received January 31, 2007

DOI: 10.5755/j02.mech.14796