

Decision support system framework for agile manufacturing of mechanical products

L. Anuziene*, A. Bargelis**

*Kaunas University of Technology, Kęstučio 27, 44312 Kaunas, Lithuania, E-mail: leta.anuziene@ktu.lt

**Kaunas University of Technology, Kęstučio 27, 44312 Kaunas, Lithuania, E-mail: algirdas.bargelis@ktu.lt

1. Introduction

Today's manufacturing survival and success became even more difficult than ever before. It is crucially important to follow up with a change much faster, otherwise there is a threat to become distinct. Understanding changes means an adequate response providing flexibility and agility in various hierarchical company levels. Internal or invisible to the customer, is the ability of a manufacturer to be product-flexible, modular and agile. Agility in manufacturing can reduce material costs, work force, inventory, idle facility or machine time and improve material handling. While these are invisible to the customer, they do affect the overall cost, quality, and timing of a product that is very visible to the customer [1]. Agile or flexible production system is very much company or process focused; therefore, it is difficult to be duplicated by the competitors, since they often are not visible.

Strategic step to become flexible or agile is lean manufacturing [2]; it is based on the integration of production flow, process control, organization, metrics and logistics. In other words competitive producer may be able to keep the requirements of lean manufacturing and agility concurrently. Manufacturing company always feels the investments deficit; therefore it can not buy all necessary machines, in particular high and laser technologies for cost minimization and has to search for partners. Co-operation with partners creates favourable conditions for agility, but for this aim the appropriate tools and techniques are necessary to develop and apply.

Agile manufacturing is a concept of technologies and adjacent management techniques. Both approaches are closely integrated into one entire. During manufacturing enterprise evolution there were developed a number of technologies starting from general machine (GM), numerical control (NC), computer numerical control machines (CNC), robots (RB), computer aided manufacturing/computer aided process planning (CAM)/(CAPP), flexible manufacturing systems (FMS) and computer integrated manufacturing systems (CIM). The problem is to better align the real settings of manufacturing system and a significant progress of decision making techniques starting from simple work study, which is expanded to inventory management, material requirements planning, just-in-time and total quality management and finally ended up with such advanced developments as concurrent engineering and virtual manufacturing. The mentioned facilities and techniques come in accordance with product types, production volume and customer requirements.

The main objective of this research is to develop the framework of decision support system (DSS) for agile manufacturing of mechanical products in a big variety

(more than 50 types per month), and small production volumes (20-100 units per month). It involves product and process design, manufacturing engineering, production and delivery to customer. The interfaces among product design, manufacturing engineering and production management including available partners and suppliers are foreseen in the developed framework. DSS framework generates several decision options which are based on mathematical expressions, but the final verdict depends on the user.

2. Relative research

Recent developments in the area of manufacturing strategy have led to the term agile manufacturing being coined to describe the management structures, technologies and business processes associated with the shift from mass to lean manufacturing [3, 4]. Lean principles for high product variety and low volumes (HVLV) are described [5] together with the main characteristics of HVLV and explained what organizational, technological and psychological barriers appear seeking lean principles. The specific advantages are identified inherent with HVLV which can be exploited and illustrated how they are being applied within the companies.

The idea of applying DSS is not new and it is used in various areas. Decision support systems of advanced manufacturing enterprises [6] analyze the environment and characteristics of advanced manufacturing system (AMS). It is an open system with a multilayer structure a self-organizing ability and capable of responding to a continuous change in manufacturing. The proposed DSS system explains the work carried out by an interdisciplinary team composed of researchers from the adjacent fields that are involved in manufacturing system. The emerging paradigm such as agile manufacturing is discussed [7] suggesting a new methodology for achieving agility. This methodology consists of the three blocks frame: agility drivers, capabilities, agility providers and appropriate interfaces. The supply chain influences the efficiency of agile capabilities [8]. This study considers an attempt to establish measuring indices of agile capabilities in the supply chain of manufacturing system. The developed indices are used in an empirical investigation of agile capabilities in the European supply chain network. The cooperation activity among partners involved in common manufacturing business is discussed in research [9]. It is shown that communication with partners, collection and making use of data depend on the possibility of dispersed manufacturing network. Authors of this research emphasize the agility of the supply chain models, their adaptability in the manufacturing system.

Only few research papers are related with agility

of products and processes. Decision making model is based on the proposed grading approach [10]. Modern product development concept is grounded on the product as a technical system. Such a development requires integrated solution and logistics approach through the whole product life cycle. The developed model in this paper connects the product as a technical system and the designer as a member of development team in the environment. Options of possible solutions by two different grading models are proposed. Flexible process development methodology with auxiliary software and specialized technique [11] is suggested. The focus is on small producers' network creation which helps to come closer to mass production.

The product and process quality problems could arise seeking for better agility when some partners in manufacturing system are involved [12]. Any product rework may violate delivery time. The data-mining approach proposed in this research uses production data to determine the sequence of assemblies that minimize the risk of faulty products production. The extracted knowledge plays an important role in sequencing modules and forming product families minimizing the cost of production faults.

3. DSS framework structure

Developed DSS framework tasks are presented in Fig.1 and consist of 4 main blocks: 1) finding customer needs, 2) product and process development, 3) product production, and 4) product delivery. All tasks must go to minimum if the company is agile and competitive.

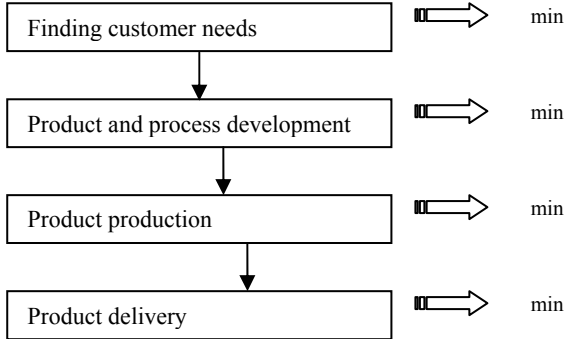

Fig. 1 DSS tasks of a manufacturing system

It is assumed that company N in the manufacturing network W is involved and interaction among company functions NF and network participant functions WF are given by the functional abstraction

$$\{NF\} = f_1\{WF\} = f_1\{S_i, P_j, C_l, N_s\} \quad (1)$$

where S_i is suppliers number and capability, P_j is partner number and capability, C_l is customer number and requirements and N_s is capability of the company itself.

Abstraction (1) is based on the available data, facts, rules and intelligent models in network W . The intelligence level of a DSS framework is defined by a number of intelligent models, rules and data. When this number is increasing the routine job volume of an engineer is decreasing; therefore the first step of manufacturing company agility is created according to the mentioned rules and techniques. There are two ways of NF development: 1) concentration of NF function number inside the company as more as possible, and 2) differentiation of NF function number into WF as more as possible.

The scope of this paper is the consideration of the second way to be more effective and contemporary in new manufacturing environment. The manufacturing functions of the second type company are illustrated in Fig. 2.

The factors of agile company functions NF (expression 1) can be expressed by a created value V , needed activity time T and cost C seeking

$$\begin{cases} V \longrightarrow \max \\ T \longrightarrow \min \\ C \longrightarrow \min \end{cases} \quad (2)$$

To reach the goal of expression (2) some contradictions are necessary to solve among V , T and C . Consistence of thinking guides when V is greater, i.e. produced product has higher performance (speed, productivity and so on), and functionality (can perform some functions, higher flexibility and etc.), then the values of T and C are going to be bigger. Therefore, the emergent contradictions are classified by the following rules.

1. Created value V is going to maximum when produced products have better performance R , functionality U , and quality Q

$$V = f_2(R, U, Q) \longrightarrow \max \quad (3)$$

2. Better product performance R , functionality U , and quality Q demand higher production time T and cost C while requirement of agility (expression 2) suggests the opposite.

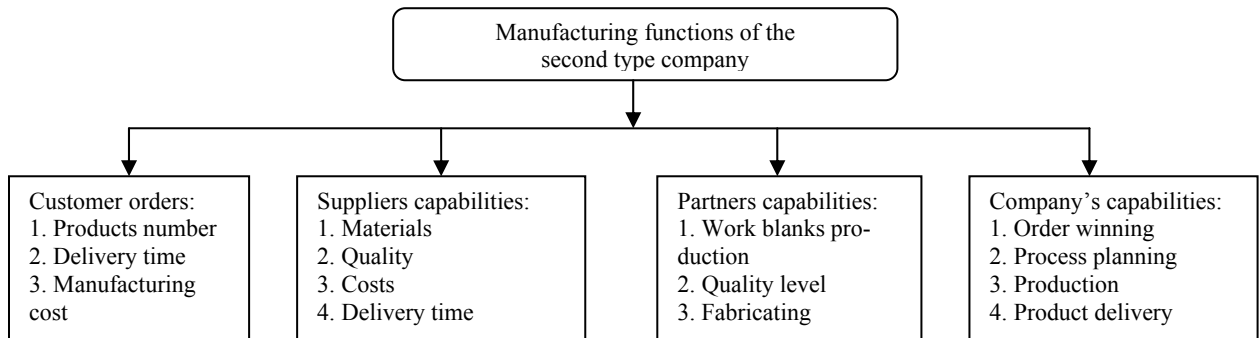

Fig. 2 Manufacturing functions of the second type company

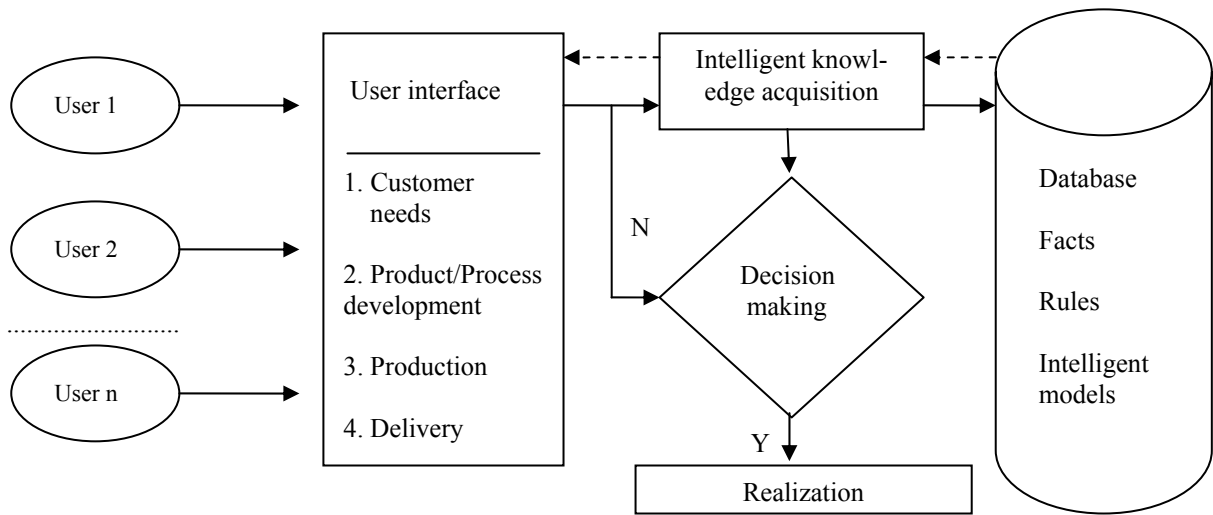

Fig. 3 DSS framework structure

$$T = f_3(t_1, t_2, t_3, t_4) \longrightarrow \min \quad (4)$$

where t_1 is customer's order engineering time, h; t_2 is product manufacturing time, h; t_3 is interfacing time h among suppliers and partners of the company; t_4 is product delivery time, h.

The developed DSS framework has a task to help solving the emergent contradictions in the second type of manufacturing system (Fig. 3). The main parts of the framework are user interface, intelligent knowledge acquisition and database with facts, rules and intelligent models. A block of appropriate rules for finding the best cooperation among producer-supplier-partner-customer is created basing on the experience of experts, facts and indices of definition expressions for production cost and time in the early order engineering and batch manufacturing stages are included in the intelligent knowledge extraction module. Database (DB) of customers, suppliers and partners is created. DB structure of suppliers capabilities is presented in Table 1 as well as partners DB structure is presented in Table 2. Material profile and its price in Table 1 are ranked according to the profile type and cost in increasing order. Analogously, partners' capability and operations are ranked in Table 2.

Contemporaneously, some users can solve and realize their tasks, but the final decision is left to the user – there is availability to exchange parent elements and repeat the process if the result appears to be inadequate.

Table 1

Suppliers' DB structure

Supplier	Material profile	Price, Eur/kg	Logistics cost, Eur/kg
Lithuanian S_1	Sheet steel	p_1	l_1
Latvian S_2	Sheet steel	p_2	l_2
Russian S_3	Sheet steel	p_3	l_3
Swedish S_4	Band steel	p_4	l_4
Finnish S_5	Band steel	p_5	l_5
Romanian S_6	Steel tube	p_6	l_6
Italian S_7	Steel tube	p_7	l_7
Polish S_8	Bar steel	p_8	l_8
Belarus S_9	Bar steel	p_9	l_9
Finnish S_{10}	Bar steel	p_{10}	l_{10}

Developed DSS framework must increase company's output; therefore, the company itself is oriented to capabilities to order winning, process planning, production and product delivery.

Supplier reliability, material quality, supply speed and other circumstances are recorded in intelligent knowledge acquisition module rules (Fig. 3) and are used for final supplier selection.

Table 2

Partners' DB structure

Partner	Operation	Costing and quality
Lithuanian P_1	Sheet laser cutting	Negotiations and discussions
Lithuanian P_2	Sheet water jet cutting	
Lithuanian P_3	Heat treatment	
Polish P_4	Plastics parts molding	
Polish P_5	Die production	
Latvian P_6	Mold production	

The window of product and process data of DSS user interface program is presented in Fig. 4. It provides data about product and process specifications for customer, product, process, costs, suppliers' and partners' data. A statistically proven measurement definition of new order cost F estimating and its winning possibility for the company is proposed.

$$F = \left(\sum_{i=1}^n \sum_{j=1}^m M_{ij} h_{ij} n_i + \sum_{i=1}^n \sum_{k=1}^t A_{ik} t_{ik} n_i \right) e \quad (5)$$

where M is material consumption for a part, kg; h is material price, Eur/kg; n is part number in the product; m is material types number; A is machinery cost including depreciation, Eur/h; t is operation time, h; l is machine tool types number for part production; e is a coefficient of company overheads, $e=1.05\div 1.30$.

Key members of Eq. (2) for cost minimization are M , h , A and t . The DSS framework supports the selection of proper decision applying technologies, facilities and processes located in WF participant network.

$$M = \left(z \int_0^x \int_0^y dy \right) \rho / k \quad (6)$$

where z , x and y are dimensions in mm of 3D CAD model of the part according to appropriate coordinate axis; ρ is material density, kg/mm³; k is material output coefficient (Table 3).

Table 3

Coefficient k values

Raw material profile	k value
Sheet metal	0.86-0.92
Band metal	0.94-0.96
Bar metal	0.70-0.80

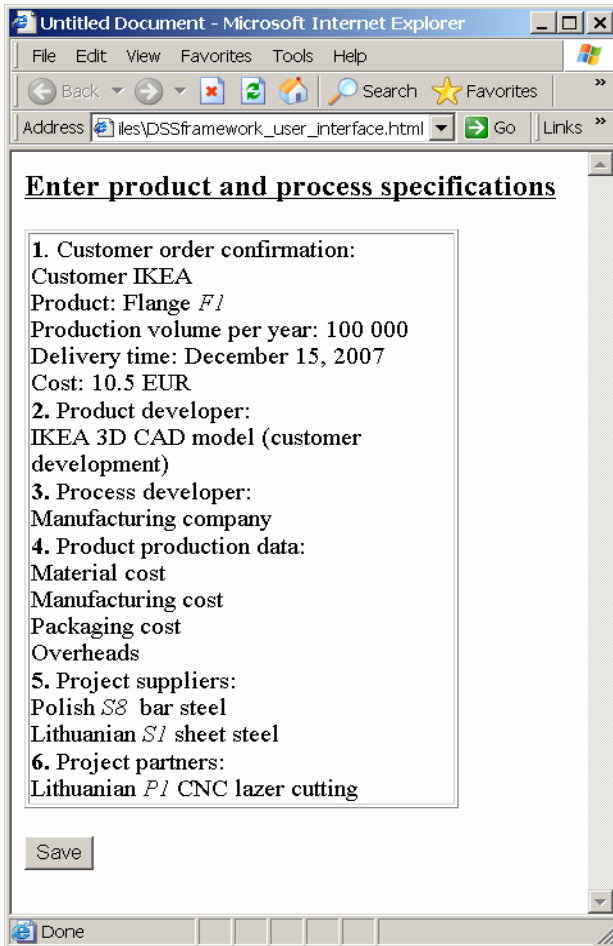

Fig. 4 DSS user interface program window

$$h = (m + l_i) * M \longrightarrow \min \quad (7)$$

where m is material profile price, Eur/kg; l_i is logistics cost for material transportation, handling and storing (Table 1 and companies' data).

$$A = \sum_{i=1}^P (A_i) \longrightarrow \min \quad (8)$$

where A_i is machine tool depreciation cost, machine operator and engineering cost in Euro (companies' data). Definition of t_i is applied by the methodology by the authors described in the research [13].

4. Results and discussions

In the investigation carried out by the paper authors it is shown that a major part of Lithuanian mechanical product producers are involved only in manufacturing engineering of process, production, and delivery of product to customer. This means no new product development and definition of customer requirements in this part of Lithuanian companies; therefore, the developed DSS framework considers the interactions of abstraction (1) production functions. The typical mechanical components group – flanges have been taken. The 3D CAD model of a flange is presented in Fig. 5, parts and dimensions and machining parameters are presented in Table 4. Using the developed framework two different manufacturing systems have been chosen: one uses laser and the second CNC machining technologies. One hour cost of machining tools is listed in Table 5. The mentioned manufacturing systems for flange production used different workpieces – the company having CNC laser cutting technology used sheet metal while the other company used CNC turning processes – bar steel. Material and logistics costs are illustrated in Table 6.

Applying parametrical Eq. (5) the material fabricating and total manufacturing costs for each type of flanges in total volume are presented in Table 7. Table 8 also represents total manufacturing expenses for CNC turning and laser cutting technologies services provided by the second supplier. Table 6 represents material profile prices in Eur per kilogram used for calculations of total manufacturing costs.

Table 4

Parts dimensions and machining parameters

Part number	D , mm	d_1 , mm	d , mm	d_2 , mm	d_3 , mm	n , mm	l , mm	l_1 , mm	Blank pieces E	Part mass m , kg	Perimeter, mm	Removed volume, mm ³
1	100	80	40	60	12.5	4	10	8	100	0.408	597	45510
2	110	90	40	60	12.5	4	10	8	90	0.511	628	54224
3	120	95	40	60	14.5	4	10	8	80	0.614	685	63892
4	130	100	45	65	14.5	4	10	8	75	0.719	732	74509
5	140	105	45	70	16.5	4	12	10	70	1.051	788	85596
6	150	110	50	80	16.5	6	12	10	70	1.213	835	97606
7	160	115	55	85	16.5	6	12	10	60	1.376	882	110657
8	170	120	55	85	16.5	6	12	10	60	1.579	914	124080
9	180	125	55	85	16.5	6	14	12	50	2.143	945	138289
10	200	130	60	90	16.5	6	14	12	50	2.667	1024	169512

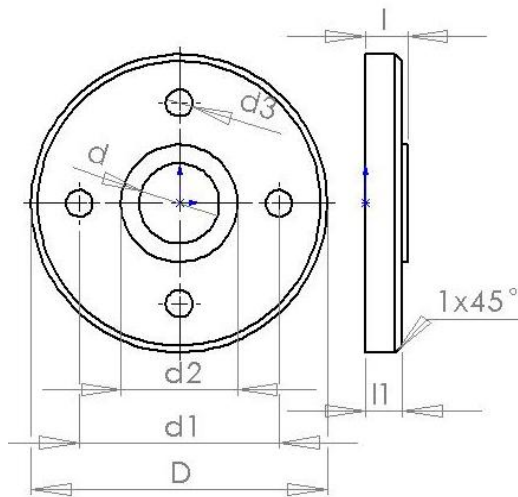

Fig. 5 Flange 3D CAD model

Machine tools one hour cost, A

Facility	A , Eur/h
Laser cutting machine	50.6
CNC turning machine	35.0
GM turning machine	10.4

Material price

Material profile	Price, Eur/kg	Logistics cost, Eur/kg
Sheet metal 10-16 mm	0.58	0.05
Bar steel 110-150 mm	0.70	0.03
Bar steel 160-210 mm	0.65	0.03

Considering data obtained in Tables 7 and 8 it is possible to conclude which manufacturing process requires more time and is more cost effective. Depending on the loads of different technologies and product delivery time a better option is chosen. Further research will incorporate the simulation of manufacturing companies with different locations, distances between them and waiting times using WEB technologies.

CNC turning cost

Part number	Material cost, Eur/kg	Fabricating cost, Eur	Total for one piece, Eur	Total for volume, Eur
1	0.547	2.80	3.35	334.69
2	0.066	2.98	3.05	274.10
3	0.078	3.08	3.16	252.60
4	0.090	3.19	3.28	246.03
5	0.104	3.33	3.43	240.40
6	0.119	3.43	3.55	248.44
7	0.125	3.92	4.05	242.72
8	0.141	5.08	5.22	313.26
9	0.158	6.30	6.46	322.88
10	0.194	9.80	9.99	499.68

Table 8
Laser cutting plus GM turning cost

Part number	Material cost, Eur/kg	Fabricating cost, Eur		Total for one piece, Eur	Total for volume, Eur
		Laser cutting	Turning		
1	0.411	2.42	0.11	2.94	294.10
2	0.497	2.60	0.13	3.23	290.46
3	0.592	2.83	0.16	3.58	286.55
4	0.695	2.96	0.18	3.83	287.60
5	0.806	3.37	0.20	4.38	306.29
6	0.925	3.78	0.22	4.92	344.74
7	1.052	3.91	0.24	5.20	312.13
8	1.188	4.07	0.27	5.53	331.67
9	1.332	4.83	0.30	6.46	323.09
10	1.644	5.15	0.33	7.12	356.20

5. Conclusions

1. Practically in most cases laser technologies are more expensive compared to other CNC machining technologies, therefore, the designed DSS framework allows to estimate on what products the application of laser technologies is cost efficient.

2. DSS framework computes total manufacturing costs including material and fabricating expenses quickly and sufficiently precisely in the early product and process design stage.

3. The application of developed framework encompasses all possible solid and sheet metal mechanical products in wide range of qualitative and quantitative parameters.

References

1. **Prasad, B.** Concurrent Engineering Fundamentals: Integrated Product and Process Organization.- Prentice Hall PTR: New Jersey, 1996.-478p.
2. **Feld, W. M.,** Lean manufacturing: Tools, Techniques and How to Use Them.- The St. Lucie Press: New York, 2000.-228p.
3. **Goldman, S. L., Nagel, R. N.** Management, technology and agility: the emergence of a new era in manufacturing.- Int. J. of Technology Management, Special issue on "New Technological Foundations of Strategic Management", 1993, v.8, No ½. p.18-38.
4. **Goldman, S. L., Nagel, R. N., Priess, K.** Agile Competitors and Virtual Organizations – Strategies for Enriching the Customer.- Van Nostrand Reinhold, New York, NY, 1995. -258p.
5. **Jina, J., Bhattasharya, A. K., Walton, A. D.** Applying lean principles for high product variety and low volumes: some issues and propositions.- Logistics Information Management, 1997, v.10, No.1. p.5-13.
6. **Fung, R. Y. K., Ren, S., Bode, J., Luo, S.** A framework of decision- support systems in advanced manufacturing enterprises – a systems view.- Integrated Manufacturing Systems, 1997, v.8, No.6. p.365-373.
7. **Zhang, Z., Shafiri, H.** A methodology for achieving agility in manufacturing organizations.- Int. J. of Operations and Production Management, 2000, v.20, No.4. p.496-512.
8. **Hock, R. I., Harrison, A., Christopher, M.** Measur-

- ing agile capabilities in the supply chain.- *Int. J. of Operations and Production Management*, 2001, v.21, No.7. p.126-147.
9. **Lau, H. C. W., Wong, C. W. Y., Pun, K. F., Chin, K. S.**, Virtual agent modeling of an agile chain infrastructure.- *Management Decision*, 2003, v.4, No.7. p.625-634.
 10. **Kozak, D., Ivandik, Z., Kljajin, M.**, Decision making model based on grading approach.- *Proceedings of the International Conference on Industrial Logistics, Vaasa – Finland 16-19 June, 2003.* p.304-312.
 11. www.fastems.com (visited on the 16th of October, 2006).
 12. **Da Cunha, C., Agard, B., Kusiak, A.** Data mining for improvement of product quality.- *Int. J. of Production Research*, 2006, v. 44, No. 18-19.p.4027-4041.
 13. **Bargelis, A., Mankute, R.**, Internet web-based integration of process and manufacturing resources planning.- *Supply chain optimisation: product/process design facility location and flow control*, Eds. Dolgui A., et al., Printed in USA ISBN 0-387-13581-7, Applied Optimization, 2005, v.94. p.233-246.

L. Anužienė, A. Bargelis

SPRENDIMŲ PARAMOS SISTEMOS
STRUKTŪROGRAMA MECHANINIŲ GAMINIŲ
VIKRIOJE GAMYBOS APLINKOJE

Reziumė

Straipsnyje pateikta sprendimų paramos sistemos struktūrograma parenka efektyviausią sprendimą, naudojant mechaninius įrengimus, metodus bei technologinius procesus galimam mechaninių gaminių gamybos partnerių tinklui. Straipsnis atspindi Lietuvos pramonės ypatumus, kai didžioji jos gamintojų dalis metalo apdirbimo pramonėje atlieka procesų kūrimo, gamybos ir produkcijos pristatymo vartotojui funkcijas. DSS struktūrogramos vartotojo sąsajos modelis buvo sukurtas ir programuojamas naudojant internetinių tinklalapių kūrimo technologijas. Struktūrograma įvertina įvairių produktų gamybos sąnaudas, jas lygina ir parenka mažiausiųjų alternatyvą. DSS struktūrograma buvo patikrinta tipinių mechaninių komponentų – flanšų gamybos atveju, taip pat gali būti taikoma sudėtingesnėse gamybos aplinkose.

L. Anuziene, A. Bargelis

DECISION SUPPORT SYSTEM FRAMEWORK FOR
AGILE MANUFACTURING OF MECHANICAL
PRODUCTS

Summary

This paper presents the decision support system (DSS) framework which allows the selection of proper decision applying technologies, facilities and processes located in partner network of mechanical products. The paper is relevant to Lithuanian industry where the major part of producers in manufacturing engineering are concerned with process, production, and product delivery to the customer. DSS framework interface was modelled and programmed using WEB based technologies. The framework computes manufacturing costs of different product machining options that are compared and the most cost efficient choice is selected. The DSS framework was tested by mechanical components-flanges and may be applicable in more complicated manufacturing environments.

L. Анужене, А. Баргялис

СТРУКТУРА СИСТЕМЫ ПОДДЕРЖКИ РЕШЕНИЯ
ДЛЯ ПРОВОРОННОГО ПРОИЗВОДСТВА
МЕХАНИЧЕСКИХ ПРОДУКТОВ

Резюме

Представлена структура системы поддержки решения, которая поддерживает выбор надлежащего решения, применяющей технологии, средства обслуживания и обрабатывает расположенный в участниках сети для механических продуктов. Статья уместна литовской промышленности, где главная часть производителей продукта в технологии машиностроения заинтересована процессом, производством, и поставкой продукта клиенту. Интерфейс структуры DSS был создан с использованием базовых интернетных Web технологий. Структура DSS вычисляет производственные затраты различного продукта, подвергающего вариантами машинной обработке, которые сравнены, и самый эффективный в затратах отобран. Структура DSS была проверена типичными механическими компонентами типа фланцев и поэтому может быть применимой в более сложных производственных областях механических продуктов.

Received March 16, 2007

DOI: 10.5755/j02.mech.14803