

# Analytical and experimental studies on active suspension system of light passenger vehicle to improve ride comfort

M. Senthil kumar\*, S. Vijayarangan\*\*

\*Faculty of Mechanical Engineering, PSG College of Technology, Coimbatore 641 004, India,  
E-mail: msenthil\_kumar@hotmail.com

\*\*Faculty of Mechanical Engineering, Dr.Mahalingam College of Engineering and Technology, Pollachi 642 103, India,  
E-mail: svrangan05@yahoo.com

## 1. Introduction

Suspension systems have been widely applied to vehicles, right from the horse-drawn carriages with flexible leaf springs fixed at the four corners, to the modern automobiles with complex control algorithms. Every vehicle moving on the randomly profiled road is exposed to vibrations which are harmful both for the passengers in terms of comfort and for the durability of the vehicle itself. Therefore the main task of a vehicle suspension is to ensure ride comfort and road holding for a variety of road conditions and vehicle maneuvers. This in turn would directly contribute to the safety.

In general, a good suspension should provide a comfortable ride and good handling within a reasonable range of deflection. Moreover, these criteria subjectively depend on the purpose of the vehicle. Sports cars usually have stiff, hard suspensions with poor ride quality while luxury sedans have softer suspensions but with poor road handling capabilities. Therefore, in a good suspension design it is important is given to fairly reduce the disturbance to the outputs (e.g. vehicle height etc). A suspension system with proper cushioning needs to be "soft" against road disturbances and "hard" against load disturbances. A heavily damped suspension will yield good vehicle handling, but also transfers much of the road input to the vehicle body. When the vehicle is traveling at low speed on a rough road or at high speed in a straight line, this will be perceived as a harsh ride. The vehicle operators may find the harsh ride objectionable, or it may physically damage vehicle. Where as a lightly damped suspension will yield a more comfortable ride, but would significantly reduce the stability of the vehicle at turns, lane change maneuvers, or during negotiating an exit ramp. Therefore, a suspension design is an art of compromise between these two goals. A good design of a passive suspension can work up to some extent with respect to optimized riding comfort and road holding ability, but cannot eliminate this compromise.

The traditional engineering practice of designing a spring and a damper of a suspension system shown in Fig. 1 are two separate functions that has been a compromise from its very inception in the early 1900's. This also applies to modern wheel suspensions and therefore a break-through to build a safer and more comfortable car out of passive components is below expectation. The answer to this problem seems to be found only in the development of an active suspension system.

In recent years, considerable interest appeared in the use of active vehicle suspensions, which can overcome some of the limitations of passive suspension systems.

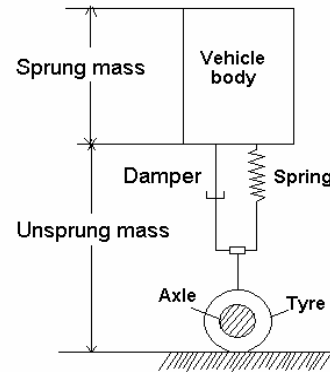

Fig. 1 Quarter car model a Passenger car

Demands for better ride comfort and controllability of road vehicles has motivated many automotive industries to consider the use of active suspensions. These electronically controlled active suspension systems can potentially improve the ride comfort as well as the road handling of the vehicle simultaneously.

Active vehicle suspensions have attracted a large number of researchers in the past few decades, and comprehensive surveys on related research are found in publications by Elbeheiry (1995), Hedrick and Wormely (1975), Sharp and Crolla (1987), Karnopp (1995) and Hrovat (1997). These review papers classify various suspension systems discussed in literature as passive, active (or fully active) and semiactive (SA) systems. In passive systems, the vehicle chassis is supported by only springs and dampers. While in active systems, of the springs and dampers are replaced, in part or fully by actuators. These act as force producers according to some control law, using the feedback from the vehicle. Semiactive suspension systems are considered to be derived from active systems, with the actuator replaced by controllable damper and a spring in parallel. These employ a feedback control to track the force demand signal, which is similar to the corresponding active system. In conditions where the active system would perform work, the demanded damper force is zero. The application of fully active suspension is restricted by the size, weight, power requirements, cost and the bandwidth of the actuators. Semiactive suspensions have only dissipative elements, and hence are limited in their capabilities. Damping control, typically achieved through orifice control, is an established technology in existing vehicles which has been studied in the past by Crosby and Karnopp (1973) and Karnopp (1983). The capability of road vehicles with pneumatic springs for achieving self-leveling and variable ride-height has been dealt by Cho and Hedrick

(1985). Although advantages of variable stiffness have been illustrated in the literature by Karnopp and Margolis (1984), no system with independent control of stiffness has been proposed so far.

In active suspension systems, sensors are used to measure the accelerations of sprung mass and unsprung mass and the analog signals from the sensors are sent to a controller. The controller is designed to take necessary actions to improve the performance abilities already set. The controller amplifies the signals which are fed to the actuator to generate the required forces to form closed loop system (active suspension system) Fig. 2. The performance of this system is then compared with that of the open loop system (passive suspension system).

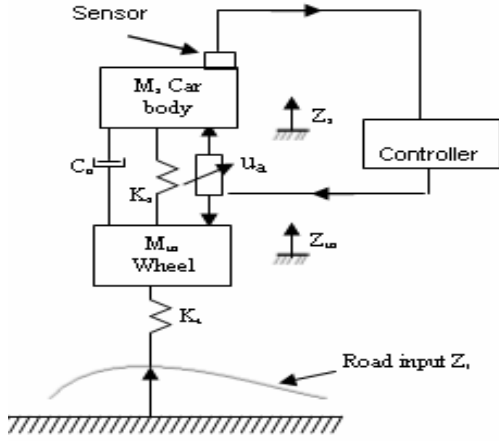

Fig. 2 Active suspension system

The developed design allows the suspension system to behave differently in different operating conditions, without compromising on road-holding ability. The effectiveness of this control method has been explained by data from time domains. Proportional-Integral-Derivative (PID) controller has been developed. The Ziegler – Nichols tuning rules are used to determine proportional gain, reset rate and derivative time of PID controller. The experimental investigations on the performance of the developed active suspension control are demonstrated through comparative simulations.

## 2. Active suspension system

In active suspension systems hydraulic actuators are added to the passive components as shown in Figure 2. The systems advantage is that even if the active hydraulic actuator or the control system fails, the passive components continue to operate. The equations of motion are written as

$$\left. \begin{aligned} M_s \ddot{Z}_s + C_a (\dot{Z}_s - \dot{Z}_{us}) + K_s (Z_s - Z_{us}) - u_a &= 0 \\ M_{us} \ddot{Z}_{us} + C_a (\dot{Z}_{us} - \dot{Z}_s) + K_s (Z_{us} - Z_s) + \\ + K_t (Z_{us} - Z_r) + u_a &= 0 \end{aligned} \right\} \quad (1)$$

where  $u_a$  is the control force from the hydraulic actuator.

Considering  $u_a$  as the control input, the state-space representation of Eq. (1) becomes

$$\left. \begin{aligned} \dot{Z}_1 &= Z_2 \\ \dot{Z}_2 &= \frac{1}{M_s} [K_s (Z_1 - Z_3) + C_a (Z_2 - Z_4)] \\ \dot{Z}_3 &= Z_4 \\ \dot{Z}_4 &= \frac{1}{M_{us}} [K_s (Z_1 - Z_3) + C_a (Z_2 - Z_4) + K_t (Z_3 - Z_r)] \end{aligned} \right\} \quad (2)$$

where  $Z_1 = Z_s, Z_2 = \dot{Z}_s, Z_3 = Z_{us}$  and  $Z_4 = \dot{Z}_{us}$ .

## 3. Controller design

The controller design is defined by

$$U_c = K_p e(t) + \frac{K_p}{K_p} \int_0^t e(t) dt + K_p T_d \frac{de(t)}{dt} \quad (3)$$

$U_c$  is the current input from the controller,  $K_p$  is the proportional gain,  $T_i$  and  $T_d$  is the integral and derivative time constant of the PID controller respectively.

The values of gain margin and phase margin obtained from the frequency response plot of car body displacement of the passive suspension system are used to determine the tuning parameters of the PID controller for the active quarter car model. The Ziegler-Nichols tuning rules are used to determine proportional gain, reset rate and derivative time of PID controller.

## 4. Tuning of PID controller

Ziegler and Nichols proposed rules for determining the proportional gain  $K_p$ , integral time  $T_i$ , and derivative time  $T_d$  based on the transient response characteristics of a given system.

According to this method, we first set  $T_i = \infty$  and  $T_d = 0$ . Using the proportional control action only  $K_p$  is increased from 0 to a critical value  $K_{cr}$  at which the output first exhibits sustained oscillations. Thus the critical gain  $K_{cr}$  and the corresponding period  $P_{cr}$  are experimentally determined. The values of the parameters  $K_p$ ,  $T_i$ , and  $T_d$  are set according to Ziegler-Nichols tuning rules.

Table 1

Ziegler-Nichols tuning rules

Type of Controller	$K_p$	$T_i$	$T_d$
P	$0.5 K_{cr}$	$\infty$	0
PI	$0.45 K_{cr}$	$0.83 P_{cr}$	0
PID	$0.6 K_{cr}$	$0.5 P_{cr}$	$0.125 P_{cr}$

From the quarter car model analysis the bandwidth and gain margin of the system are found to be 1.92 Hz and -13.9 db respectively. Gain margin is the gain, at which the active suspension (closed loop) system goes to the verge of instability; (Gain margin is the gain in db at which the phase shift of the system is  $-180^\circ$ ). The gain margin of the system is found to be 4.91. It is the value of the gain, which makes the active suspension (closed loop) system to exhibit sustained oscillations (the vibration of the car body is maximum for this of gain value).

When the gain of the system is increased beyond 4.915 the response (vibration amplitude) of the active suspension (closed loop) system is increased instead of being reduced. The system becomes unstable when the gain of the system is increased beyond 4.915 which are shown in Fig. 3.

The response of the active suspension for the critical gain value ( $K_{cr} = 4.915$ ) is shown in Fig. 4. The time period of the sustained oscillation for this value of critical gain  $K_{cr}$  is called critical period  $P_{cr}$ , which is determined from the step response of the closed loop system and is found to be  $P_{cr} = 0.115$  sec.

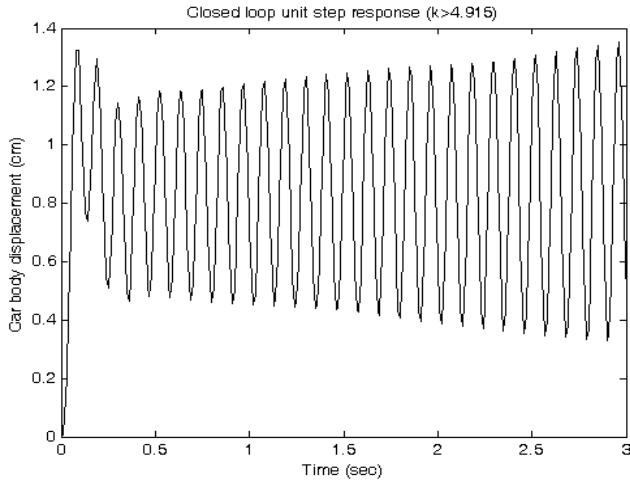

Fig. 3 Closed loop unit step response ( $k > 4.915$ )

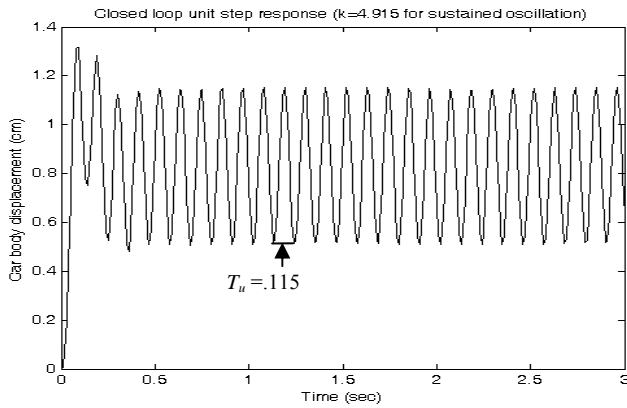

Fig. 4 Closed loop unit step response ( $k = 4.915$ ) for sustained oscillation

The critical gain ( $K_{cr}$ ) and critical time period ( $P_{cr}$ ), determined above are used to set the tuning rules for the quarter car model using the Zeigler-Nichols tuning rules. As discussed, the values for P, PI and PID controllers are obtained (Table 2).

Zeigler-Nichols tuning values

Type of Controller	$K_p$	$T_i$	$T_d$
P	2.4575	$\infty$	0
PI	2.212	0.096	0
PID	2.95	0.0575	0.014

Table 2

## 5. Simulation

To ensure that our controller design achieves the desired objective, the open loop passive and closed loop active suspension system are simulated with the following values.

Table 3

$M_b = 290$ kg	$K_r = 190000$ N/m
$M_{us} = 60$ kg	$C_a = 1000$ N/(m/sec)
$K_a = 16800$ N/m	

## 6. Bumpy road (Sinusoidal Input)

A single bump road input,  $Z_r$  as described by Jung-Shan Lin (1997), is used to simulate the road to verify the developed control system. The road input described by Eq. (4) is shown in Fig. 5.

$$Z_r = \begin{cases} a(1 - \cos \omega t) & 0.5 \leq t \leq 0.75 \\ 0 & \text{otherwise} \end{cases} \quad (4)$$

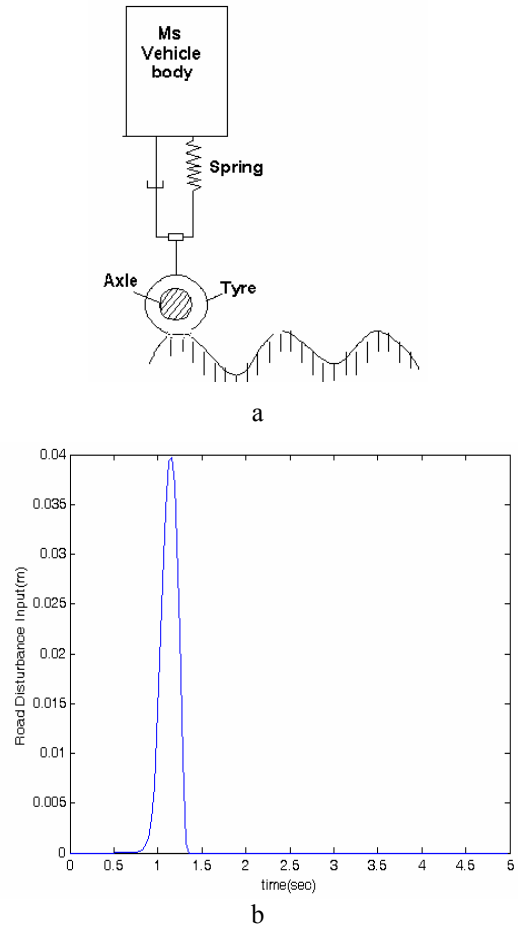

Fig. 5 Road input disturbance: a - bumpy road, suspension travel limits:  $\pm 8$  cm; b - spool valve displacement,  $\pm 1$  cm Actual bumpy road input

In Eq. (4) the road disturbance, 'a' is set to 0.02 m to achieve a bump height of 4 cm. All the simulations are carried out by MATLAB software. The following assumptions are also made in running the simulation.

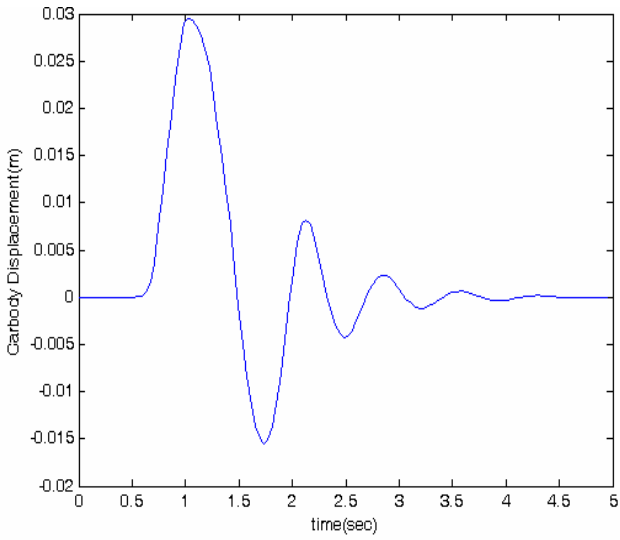

Fig. 6 Body displacement of the a car with passive suspension system

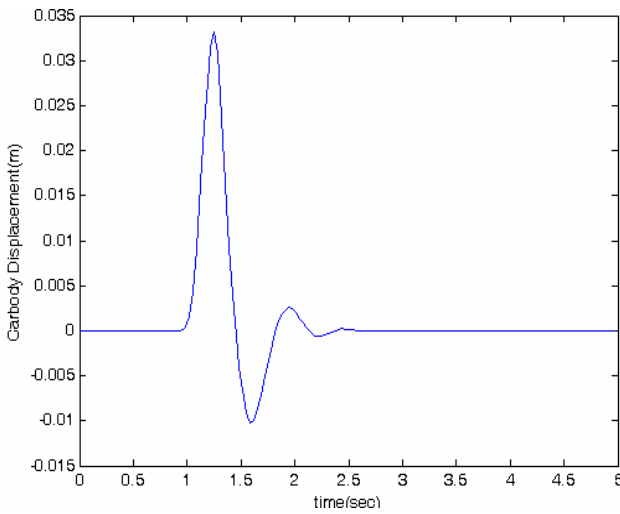

Fig. 7 Body displacement of a car with active suspension system

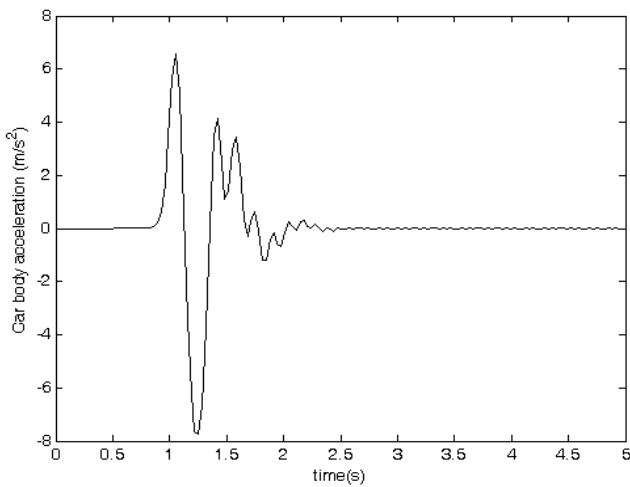

Fig. 8 Body acceleration of a car with passive suspension system

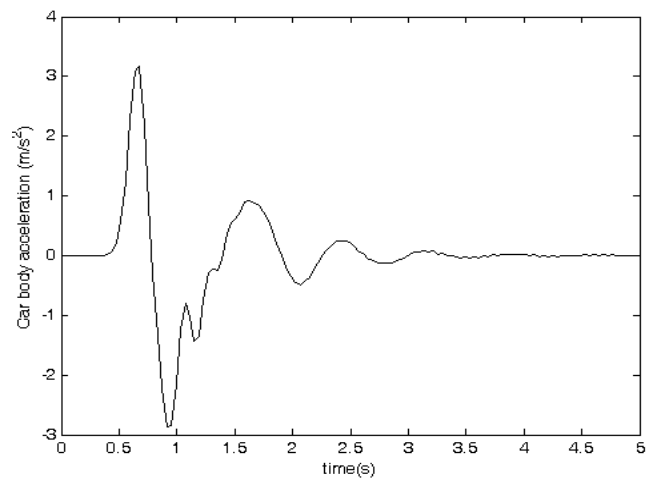

Fig. 9 Body acceleration of a car with active suspension system

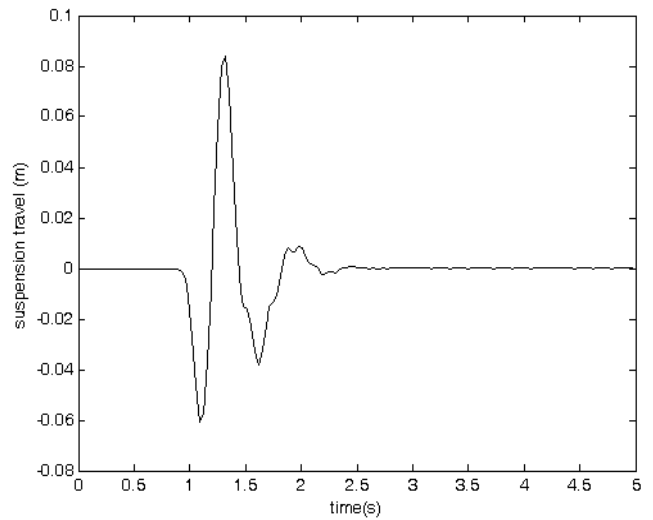

Fig. 10 Passive suspension travel

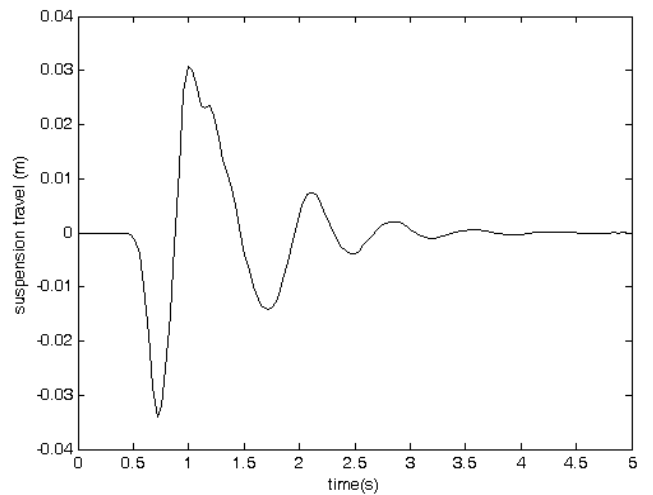

Fig. 11 Active suspension travel

Figs. 6-11 represent the time response plots of car body displacement, car body acceleration and suspension travel of both passive and active suspension system without tuning of controller parameters respectively. The PID controller designed produces a large spike (0.0325 m) in the transient portion of the car body displacement response

of active suspension system as shown in Fig. 7. The response (0.03 m) of passive suspension system shown in Fig. 6. The spike is due to the quick force applied by the actuator in response to the signal from the controller. Even though there is a slight penalty in the initial stage of transient vibration in terms of increased amplitude of displacement, the vibrations are settled out faster as it takes only 2.5 sec against 4.5 sec taken by the passive suspension system as found from Fig. 7. The force applied between sprung mass and unsprung mass would not produce an uncomfortable acceleration for the passengers of the vehicle, which is depicted in Figure 8 ( $3.1 \text{ m/s}^2$  in active system), in comparison with the acceleration ( $6.7 \text{ m/s}^2$ ) of passenger experienced in passive system as shown in Fig. 8. Also, it is found that the suspension travel (0.031 m) is very much less as seen in Fig. 11 compared with suspension travel (0.081 m) of passive suspension system as seen in Fig. 10. Therefore rattle space utilization is very much reduced in active suspension system when compared with passive suspension system in which suspension travel limit of 8 cm is almost used.

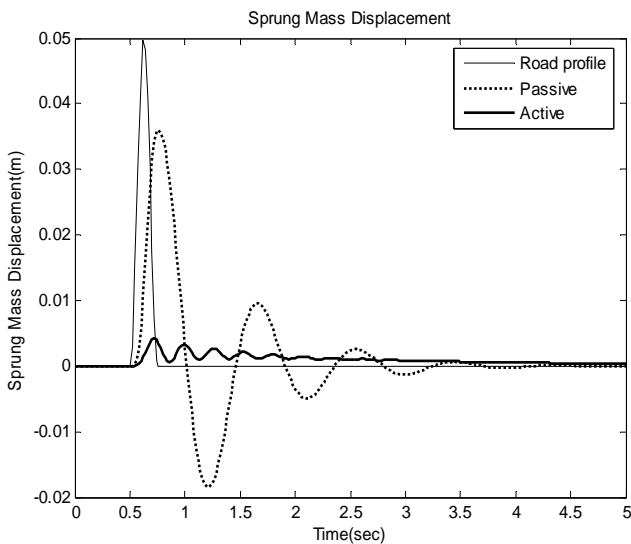

Fig. 12 Sprung mass displacement Vs time (Bumpy road)

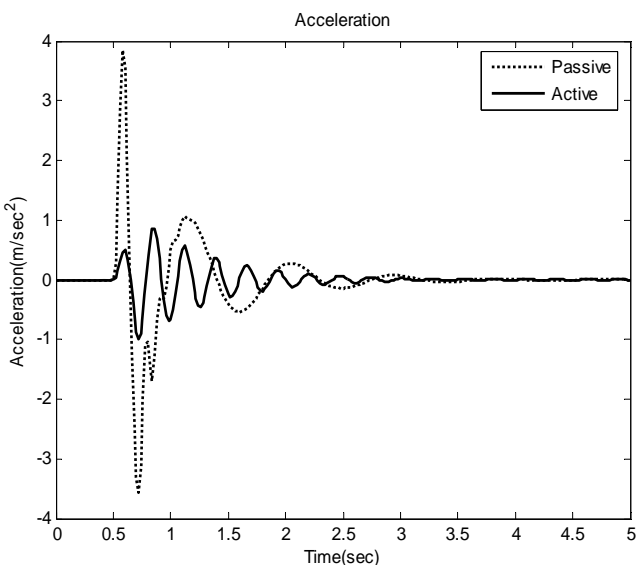

Fig. 13 Sprung mass acceleration Vs time (Bumpy road)

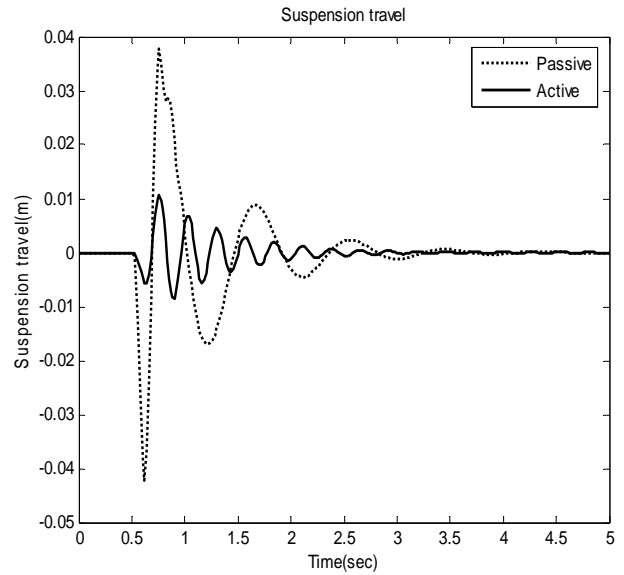

Fig. 14 Suspension travel Vs time (Bumpy road)

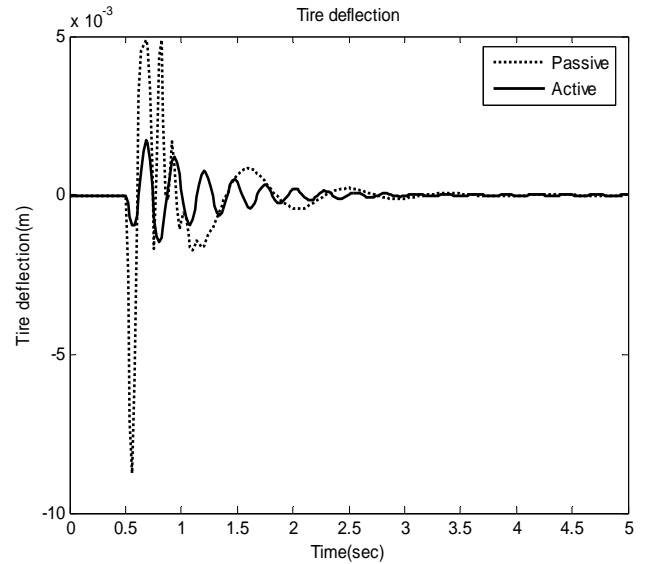

Fig. 15 Tyre deflection Vs time (Bumpy road)

Figs. 12-15 represent the behavior of both passive and active suspension system with tuned parameters.

Figs. 12-15 illustrate that both peak values and settling time have been reduced by the active system compared to the passive system for all the parameters - sprung mass displacement, sprung mass acceleration (ride comfort), suspension travel and tyre deflection (road holding).

Table 4  
Reduction in peak values different parameters (Bumpy road)

Parameter	Passive	Active	Reduction, %
Sprung mass acceleration	$3.847 \text{ m/s}^2$	$0.845 \text{ m/s}^2$	78.03
Suspension travel	0.038 m	0.011 m	71.05
Tyre deflection	0.005 m	0.002 m	60.00

## 7. Experimental results and discussion

In this section, experimental results are presented

to examine the performance of PID controller. In the complete system experiments, the performance under integrated main-loop is assessed. Sprung mass acceleration, unsprung mass acceleration, sprung mass displacement, unsprung mass displacement, suspension travel and tyre deflection for the different road frequency and bump combinations are used to present the effectiveness of the controller at various frequencies. Fig. 16 shows the experimental set up.



Fig. 16 Experimental set-up

The input and output data are transferred from and to control system (PC) through data acquisition card (DAQ card). The PID control system has been designed and the hardware and software are interfaced using LABVIEW software. Road bump height of 4 cm has been used with three different frequencies of 0.5 Hz, 0.75 Hz and 1 Hz. Performance parameters like sprung mass displacement, sprung mass acceleration, suspension travel, road holding ability and settling time have been measured for both passive and active suspension systems.

Figs. 17-19 show the performance of both passive and active suspension systems subjected to 4 cm bumpy road with 0.5 Hz, 0.75 Hz and 1 Hz road frequencies. The ride comfort has been improved by reduced acceleration using active suspension system. Important settling time for three different road profiles has been reduced considerably. Rattle space utilization has also been considerably reduced. As excitation frequency increases, the performance of active suspension deteriorates. However it is still better than the passive suspension system.

Also, it is found that, at higher frequencies (1 Hz and more) the performance of active suspension system deteriorates as force tracking at higher frequencies is difficult because of the limitation of hydraulic system.

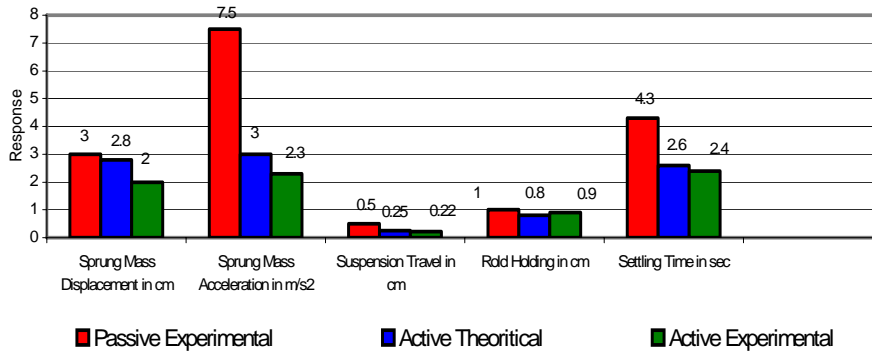

Fig. 17 Responses of suspension systems for a bump height of 4 cm and frequency of 0.5 Hz

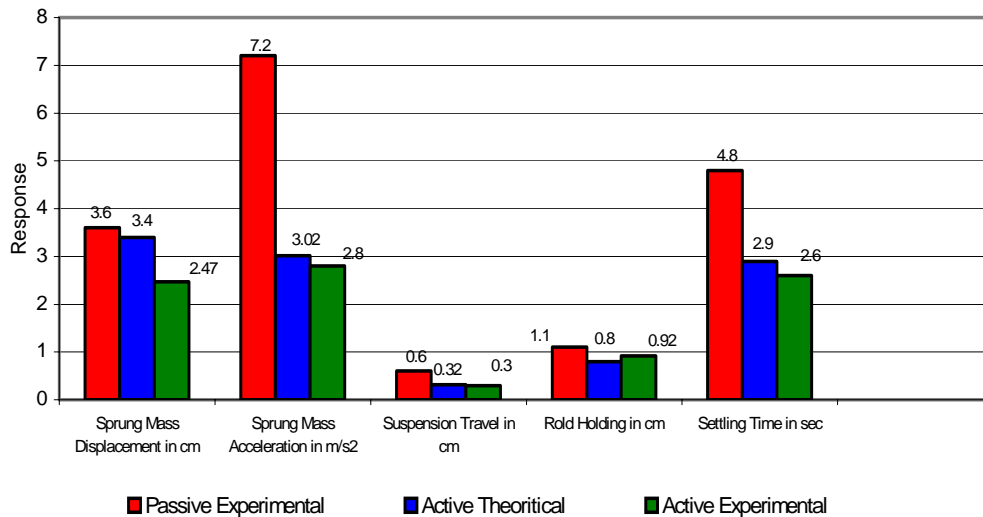

Fig. 18 Responses of suspension systems for a bump height of 4 cm and frequency of 0.75 Hz

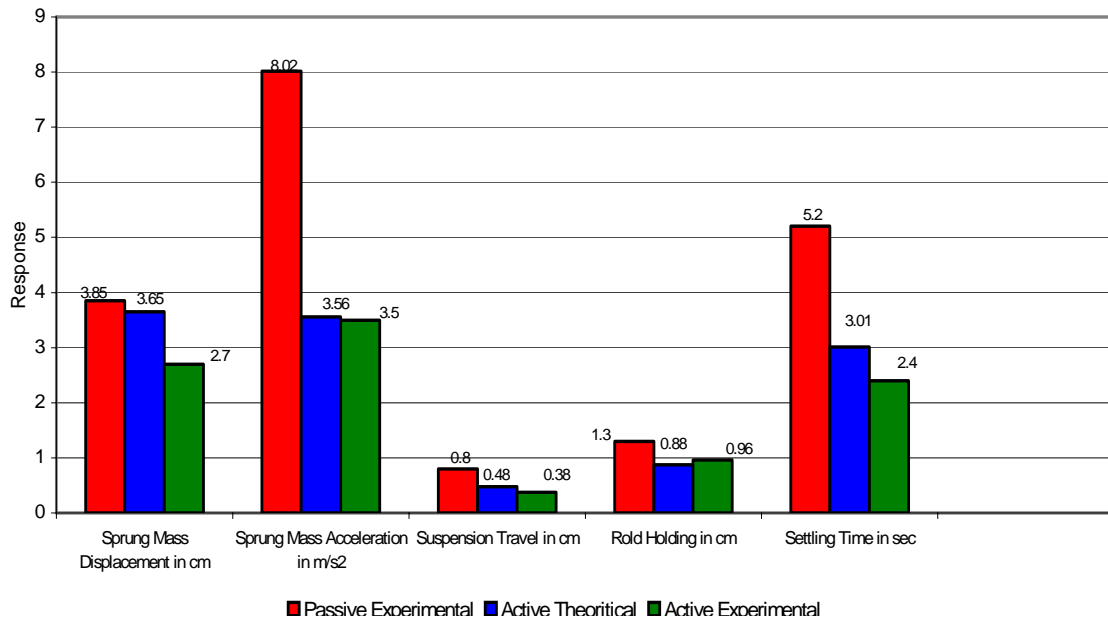

Fig. 19 Responses of suspension systems for a bump height of 4 cm and frequency of 1 Hz

## 8. Conclusions

1. Active suspension system has been developed using PID controller including hydraulic dynamics. When the gain of the system is increased beyond 4.915, the response (car body displacement amplitude) of the active suspension system is increased instead of being reduced. The system becomes unstable when the gain of the system is increased beyond 4.915. Therefore, it is found that gain increasing of the system may not result in better performance.

2. Active suspension system has improved ride comfort (78% reduction in acceleration). However there is no appreciable improvement in road holding ability with active suspensions system observed.

3. Experimental results show that active suspension system works better than both experimental passive and theoretical active suspension system. Also, it is found that, at higher frequencies (1 Hz and more) the performance of active suspension system deteriorates as force tracking at higher frequencies is difficult.

4. It is also found that active suspension system improves ride comfort even at resonant frequency.

## References

1. **Elbeheiry, E.M.** Advanced ground vehicle suspension systems.-Vehicle System Dynamics, 1995, v.24, p.231-258.
2. **Hedrick, J.K., Wormely, D.N.** Active suspension for ground support transportation.-ASME-AMD, 1975, v.15, p.21-40.
3. **Sharp, R.S., Crolla D.A.** 'Road vehicle suspension system design.-Vehicle System Dynamics, 1987, vl.16, No.3, p.167-192.
4. **Karnopp, D.C.** Active and semi-active vibration isolation.-J. of Mechanical Design, 1995, v.117, p.177-185.
5. **Hrovat, D.** Survey of advanced suspension development and related optimal control application. -Automatica, 1997, v.30, No.10, p.1781-1817.
6. **Crossby, M.J., Karnopp D.C.** The active damper: a

new concept for shock and vibration control.-The Shock and Vibration Bulletin, 1973, v.43, No.4, p.119-133.

7. **Cho, D., Hedrick J.K.** Pneumatic actuators for vehicle active suspension applications.-A.S.M.E. J. of Dynamic Systems, Measurement and Control, 1985, v.107, p.67-72.
8. **Karnopp, D.C., Margolis D.** Adaptive suspension concepts for road vehicles.-Vehicle System Dynamics, 1984, v.13, p.145-160.
9. **Jung-Shan Lin.** Nonlinear design of active suspensions.-34th IEEE Conference on Decision and Control. -New Orleans, LA, 1997, p.11-13.

M. Senthil kumar, S. Vijayarangan

AKTYVIOSIOS LENGVOJO AUTOMOBILIO  
PAKABOS TEORINĖ IR EKSPERIMENTINĖ  
ANALIZĖ SIEKiant pagerinti VAŽIAVIMO  
PATOGRAMĄ

R e z i u m ė

Nagrinėjamos kaip pagerinti važiavimo patogumą tobulinant lengvojo automobilio aktyviosios pakabos PID (proporcinis – integruojantis – diferencijuojantis) valdiklį. Sistema pritaikyta nelygiam keliui, įvertintos jos eksploatacinės charakteristikos bei palygintos su pasyvosios pakabos sistemos charakteristikomis. Aprašytas valdiklio parametrų derinimas. Atliktas analitinių ir eksperimentinių rezultatų palyginimas. Nustatyta, kad, naudojant aktyviąją pakabos sistemą, palyginus su pasyviaja pakabos sistema, važiavimo patogumas pagerėja 78.0 %, pakabos eiga sumažėja 71.05 %, kelio stabilumo užtikrinimas pagerėja 60%. Todėl daroma išvada, kad aktyvioji pakabos sistema su PID valdikliu pranašesnė už pasyviąją pakabos sistemą.

M. Senthil kumar, S. Vijayarangan

ANALYTICAL AND EXPERIMENTAL STUDIES ON ACTIVE SUSPENSION SYSTEM OF LIGHT PASSENGER VEHICLE TO IMPROVE RIDE COMFORT

S u m m a r y

This paper describes the development of active suspension system of light passenger vehicle to improve ride comfort of the passengers using PID (Proportional – Integral - Derivative) controller. The system is subjected to bumpy road and its performance is assessed and compared with a passive suspension system. Tuning of the controller parameters is also illustrated. Experimental verification of analytical results is carried out. It is found that ride comfort is improved by 78.03%, suspension travel has been reduced by 71.05% and road holding ability is improved by 60% with active suspension system when compared with passive suspension system. Therefore it is concluded that active suspension system with PID controller is superior to passive suspension system.

М. Сентгил кумар, С. Виивоаиаранган

ТЕОРЕТИЧЕСКИЙ И ЭКСПЕРИМЕНТАЛЬНЫЙ АНАЛИЗ АКТИВНОЙ ПОДВЕСКИ ЛЕГКОВОГО АВТОМОБИЛЯ С ЦЕЛЬЮ УСОВЕРШЕНСТВОВАНИЯ КОМФОРТНОСТИ ЕЗДЫ

Р е з ю м е

С целью усовершенствования удобства езды на легковом автомобиле, исследуются проблемы усовершенствования его активной подвески при использовании PID (пропорционный – интегрирующий – дифференцирующий) регулятора. Система приспособлена к неровной дороге, установлены ее эксплуатационные характеристики и сравнены с характеристиками пассивной системой подвески. Описана наладка параметров регулятора. Произведено сравнение результатов аналитических и экспериментальных исследований. Определено, что при использовании системы активной подвески автомобиля, удобство езды улучшилось на 78%, ход подвески уменьшился на 71%, улучшилась стабильность автомобиля на 60% по сравнению с пассивной подвеской. В связи с этим делается вывод, что система активной подвески с PID регулятором более эффективна по сравнению с пассивной подвеской автомобиля.

Received March 28, 2007

DOI: 10.5755/j02.mech.14828