

Numerical simulation of parts alignment under kinematical excitation

B. Bakšys*, J. Baskutienė**

*Kaunas University of Technology, Kęstučio 27, 44312 Kaunas, Lithuania, E-mail: bronius.baksys@ktu.lt

**Kaunas University of Technology, Kęstučio 27, 44312 Kaunas, Lithuania, E-mail: jbask@ktu.lt

1. Introduction

One of the basic manufacturing operations, mainly predetermining production quality, is assembly of the parts. Assembly automation is highly important manufacturing development trend, which makes possible to decrease duration of the manufacturing operations, save resources and increase production quality. Success of the automated assembly of the parts depends on parts feeding into assembly position, their location, interdependent alignment and joining operations.

The accuracy of the relative position of the parts in locating mechanisms of the assembly devices often is insufficient and, therefore, automated assembly is impossible. As it is economically unprofitable to stricthen the requirements regarding tolerances of mechanisms and manufacturing of the being assembled parts, then the devices for interdependent alignment of the parts are used. Consequently, it is necessary to place the parts in assembly position ensuring such accuracy, that their alignment and unhindered assembly is possible. It is necessary to choose such method of alignment, that the following condition is satisfied

$$\Delta_y < \varepsilon$$

where Δ_y is total error of interdependent position of the connective parts; ε is allowable axial misalignment, under which unhindered assembly of the parts is possible.

The allowable misalignment ε defines technological possibilities of the assembly mechanism and depends on geometry, force and stiffness parameters of the assembly process. Optimization of the mentioned parameters provides the possibility to define maximal value of ε . For example, in cylindrical parts assembly, displacement ε depends on: joining clearance or preload magnitude, chamfer angle of the parts, connective diameter, length of the connective part, angle between axes of the parts, roughness of connective surfaces and etc.

Alignment of the parts being assembled may be accomplished by different techniques. It is common practice to use devices with alignment elements, such as rods, catchers, cotter pins, cones, levers, pawls and etc. As alignment elements connective surfaces and auxiliary surfaces, chamfers can be used. For the reason that during alignment the parts should be able to move relative to the mating part, assembly mechanisms are provided with elastic compensators. While selecting the method for being assembled parts alignment, geometry and dimensions of the parts are taken into account, specifics of parts feeding and fastening devices and accuracy parameters are also considered. Properly chosen alignment method of the parts provides a possibility to reduce contact forces and avoid

breakage of the parts and devices.

To align the parts being assembled automatically pneumovortical devices are used [1], consisting of a rod with a plate on it, which has particular cavities for the being assembled part. As compressed air is fed into the bushing, the plate rotates and swings and the part on the plate gets successfully aligned and falls into corresponding cavity. Also are known techniques, when parts get aligned applying magnetic or electric fields [2]. In high precision positioning more widely application obtain micro-electromechanical system (MEMS) technology [3], vision systems, feedback systems and information from force/moment or etc. sensors. Application of the mentioned methods is related to significant expenses, since complex control devices and control algorithms are necessary.

Within the past few years, having objective to increase efficiency of the assembly processes, significant amount of research have been done related to the application of vibrations for automated assembly. Jamming or wedging may occur during assembly. If joining of the parts fails, then one of the parts is provided with vibratory excitation, which makes possible to accomplish the process of assembly [4]. The parameters of vibrations, as functions of the position uncertainty and tolerances of the connective parts, necessary to accomplish mating, were determined. An analytical and experimental investigation of parts' mating aided by two orthogonal constant amplitude sinusoidal motions is analyzed in [5]. It is analyzed what influence on parts joining have amplitudes, frequencies and phase angle of the two motions. Theoretical modeling and parameter analysis of the vibratory robotized assembly of peg-hole parts is presented in paper [6]. The types of parts mating failures: jamming due to insufficient assembly forces, robot deflection or due to assembly geometry restrictions, wedging because of pressing forces is considered. Having objective to decrease friction and avoid jamming, assembly task by the robot with multiaxial vibrator, which is tuned to minimize the influence of friction effect and stick-slip, is considered in paper [7]. Neural network based vibratory assembly method, with the aim to reduce assembly forces, was applied for chamferless prismatic parts assembly [8]. Applying this method, interaction force is suppressed decreasing the amplitude of vibrations, whereas main part of the relative positioning error is estimated and compensated by means of the neural network. Authors of the paper [9] analyzed basic concept of the perturbation using vibratory end-effector with piezoelectric actuator and a new control strategy for force guided robotized assembly. Thus, vibrations are effective not only for friction reduction, but also their effectiveness manifests in obtaining useful information, which is necessary to direct the robot in the desired direction.

Applied vibrations assist in reducing the parts joining force or compensate part-to-part errors in assembly

position. Majority of the authors provide vibrations to one of the mating parts along the perpendicular to the assembly axis direction. To compensate positioning errors it is necessary to use feedback systems, control algorithms and other means. The mentioned systems are complicated, expensive and not always reliable. Authors of publications [10, 11] have introduced vibratory method for parts alignment, based on an effect of directional displacement of two contacting bodies, which occurs as one of the mentioned bodies is excited by vibrations of predetermined direction, amplitude and frequency. In those publications experimental analysis of two cases of alignment is given: as only movably based part is kinematically excited and when excitation is provided to the immovably based part. The performed experiments made it possible to determine parameters of vibratory alignment process only within a limited range of part geometry, rigidity characteristics of the system and excitation parameters.

Presented paper is concerned with vibratory alignment of the components under existing positioning error in assembly position. The mentioned technique is based on directional displacement of the being aligned part because of vibratory excitation along the assembly direction, provided to the movably based part. This method of alignment is also suitable under existing significant errors of connective components positioning in assembly position. Hence, low accuracy positioning devices can be used for automated assembly, whereas vibratory displacement compensates errors of the connective components position. Based on constructed generalized 3D dynamic model numerical simulation of parts alignment was carried out under varying parameters of dynamic system and excitation.

2. Dynamic model of parts alignment and geometrical conditions of contact

Under consideration is assembly case, as parts are fed into assembly position by the robot (Fig. 1).

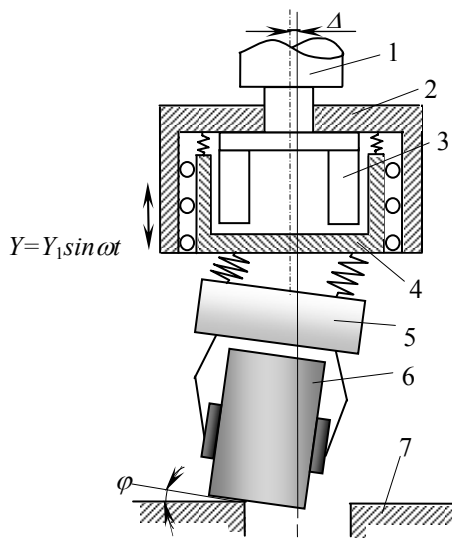

Fig. 1 Scheme of vibratory alignment under kinematical excitation: 1 – robot arm; 2 – housing of electromagnetic vibrator; 3 – electromagnet; 4 – gripper holder; 5 – gripper; 6 – peg; 7 – bushing, Δ – axial misalignment of the parts; φ – tilt angle

Movably based part 6 is grasped by the gripper 5, which through elastic elements of the gripper holder 4 is attached to the robot arm 1. Connective part 7 is immovably based in assembly position.

Due to robot manipulator positioning, parts location and other errors, axes of the parts in assembly position may be displaced by particular value Δ . Under existing axial misalignment, approached and pressed by predetermined magnitude force movably based part gets tilted relative to the immovably based part 7 and takes stable equilibrium position.

The force asymmetry of the mechanical system is predetermined by tilt of the part 6 due to deformation of the elastic elements, whereas kinematic asymmetry is because of the vibratory excitation of the tilted part. Vibrations, provided along the assembly direction to the gripper holder 4 and through elastic elements gripped part 6 is excited. In such a way directional vibratory displacement and turn of the movably based part, dependent on excitation law and trajectory of vibrations, occurs, what predetermine matching of the connective surfaces' contours, orientation of the parts and unhindered assembly.

Dynamic model for vibratory alignment of the parts under kinematical excitation is made taking into account real placement of the connective parts in assembly position and is presented by 3D system of movable body of mass M , which is able to move along the X and Y directions and to tilt relative to the base by the angle φ (Fig. 2). Immovably based part in dynamic model is presented by a base with a slot. Coordinate frame XOY is linked to the center of the slot.

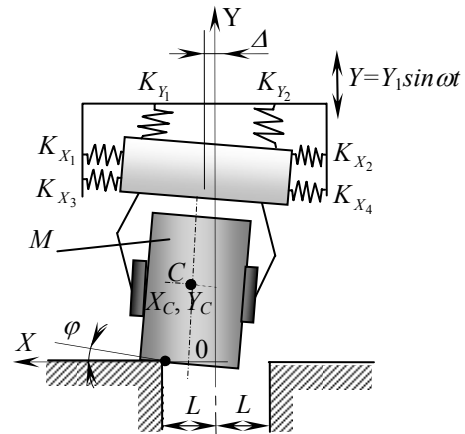

Fig. 2 Dynamic model of vibratory alignment under kinematical excitation

Position of the movably based part relative to the zero point of the coordinate frame is specified by the coordinates X_C, Y_C of the mass center, located at the point C , and tilt angle φ .

Tilt of the movably based part changes during the displacement and is dependent both on rigidity of elastic locating elements and initial pressing force. Character of the vibratory displacement, parameters, regimes of displacement and specific motion trajectories depend on excitation law and trajectory of the vibrations.

Moving on the base the body is influenced by elastic forces F_x and F_y , elastic resistance moment T_φ ,

gravity Mg , inertia forces MX_C'' and MY_C'' , rotation-preventing moment $I\varphi''$ around the C center of mass, normal reaction N at the point of contact with the base, static pressing force F_0 and friction force μN (Fig. 3).

Initially the contours of connective surfaces of the parts being aligned do not coincide. Due to existing axial misalignment and because of the acting initial pressing force, movably based part is tilted relative to the connective part by particular angle. To align the parts, it is necessary to establish conditions, under which the movably based part performs directional displacement towards the immovably based part so, that the following conditions are satisfied (Fig. 4)

$$\left. \begin{array}{l} X_{B_1} \leq L \\ X_{B_2} \geq -L \\ Y_{B_1} < 0 \\ Y_{B_2} < 0 \end{array} \right\}$$

and tilts so, that direction of the parts' axes coincide.

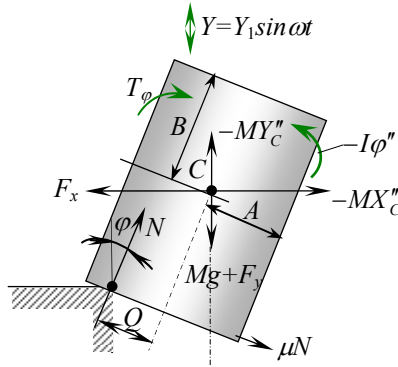

Fig. 3 Scheme of forces and moments acting on the movably based part: M is mass of the body; I is moment of inertia around the center of mass; g is acceleration gravity; μ is friction coefficient; X_C, Y_C are mass center coordinates; Y is amplitude of kinematical excitation along the assembly direction

Equations of body motion during the alignment have been made relative to its mass center C . Consequently, elastic and damping constraints are influencing the body through the gripper. Therefore, reactions of the mentioned constraints along the X, Y axes and elastic resistance moment are reducible relative to the mass center.

It is assumed, that components of the elastic elements reactions along X, Y and tilt directions, depend only on particular components of the displacement vector and first time-derivatives of the point, where elastic elements are attached to the gripper. The mentioned displacement is reducible presented relative to the inertia center. Then reactions of the elastic elements, linking the movably based part with the platform of the vibrator, are expressed by the dependencies

$$\begin{aligned} R_X &= H_X X'_C + K_X (X_C - X_{st}) \\ R_Y &= H_Y Y'_C + K_Y (Y_C - Y_{st}) \\ T_\varphi &= H_\varphi \varphi' + K_\varphi (\varphi - \varphi_{st}) \end{aligned}$$

where $X_{st}, Y_{st}, \varphi_{st}$ are coordinates of static equilibrium position; H_X, H_Y, H_φ are damping coefficients; K_X, K_Y, K_φ are stiffness coefficients, $K_Y = K_{Y_1} + K_{Y_2}$; $K_X = K_{X_1} + K_{X_2} + K_{X_3} + K_{X_4}$ (Fig. 2).

Applying D'Alambert's principle, motion equations of the body, contacting the base, are obtained

$$\left. \begin{array}{l} U_1 N - R_X - MX_C'' = 0 \\ U_2 N - R_Y - F_0 - MY_C'' = F_1 \sin \omega t \\ U_3 N - T_\varphi - I\varphi'' = 0 \end{array} \right\} \quad (1)$$

where

$$\begin{aligned} U_1 &= \sin \varphi - \mu \cos \varphi; U_2 = \cos \varphi + \mu \sin \varphi \\ U_3 &= Q + \mu B; F_0 = Mg \end{aligned}$$

Substituting R_X, R_Y and T_φ expressions, the following is obtained

$$\left. \begin{array}{l} U_1 N - H_X X'_C - K_X (X_C - X_{st}) - MX_C'' = 0 \\ U_2 N - H_Y Y'_C - K_Y (Y_C - Y_{st}) - Mg - MY_C'' = F_1 \sin \omega t \\ U_3 N - H_\varphi \varphi' - K_\varphi (\varphi - \varphi_{st}) - I\varphi'' = 0 \end{array} \right\} \quad (2)$$

where $F_1 = K_Y Y(t)$ (Fig. 2).

To determine generalized characteristics of the alignment process, dimensionless parameters are used

$$\begin{aligned} \tau &= pt; \dot{\bullet} = d/dt; p^2 = K_Y/M; \nu = \omega/p; x_c = K_Y X_C/F_1 \\ y_c &= K_Y Y_C/F_1; l = K_Y L/F_1; a = K_Y A/F_1; b = K_Y B/F_1 \\ I_\varphi &= (I/M)/(K_Y/F_1)^2; h_x = H_X/\sqrt{K_Y M} \\ h_y &= H_Y/\sqrt{K_Y M}; h_\varphi = H_\varphi(p^3 M/F_1^2); k_x = K_X/K_Y \\ k_\varphi &= K_\varphi K_Y/F_1^2; f_0 = F_0/F_1; n = N/F_1 \\ q &= K_Y Q/F_1 = \frac{l - x_c}{\cos \varphi} - btg\varphi \end{aligned}$$

Then motion equations of the movably based part, contacting immovable base, can be written in dimensionless form

$$\left. \begin{array}{l} U_1 n - h_x \dot{x}_c - k_x (x_c - x_{st}) - \ddot{x}_c = 0 \\ U_2 n - h_y \dot{y}_c - y_c - \ddot{y}_c - f_0 = \sin \nu \tau \\ U_3 n - h_\varphi \dot{\varphi} - k_\varphi (\varphi - \varphi_{st}) - I_\varphi \ddot{\varphi} = 0 \end{array} \right\} \quad (3)$$

where $U_3 = q + \mu b$. These equations (3) have been used for numerical simulation of the parts' alignment process.

3. Numerical simulation of parts alignment

Taking into account the constructed dynamical model for parts alignment and using motion equations (3) of the movably based part in contact with the base, MATLAB code was written for peg-hole type parts alignment analysis.

Motion equations (3) of the body contain the body and the base interaction force n , which depends on initial pressing force, amplitude of excitation force and position of the body relative to the plane. To obtain numerical solution of motion equations, it is necessary to estimate interaction between the body and the base and for each time instance to determine value of the n . Therefore, the base is replaced by stiffness and damping elements (Fig. 4).

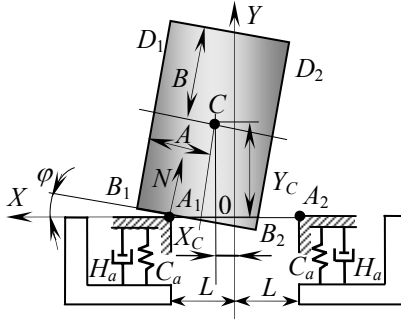

Fig. 4 Contact scheme of the being aligned components

Then it is possible to express normal reaction at the point A_1 by the dependence

$$N = -D_1 \cdot K_a - H_a \cdot \left(\sqrt{(y'_C)^2 + (x'_C)^2} \right)$$

where D_1 is deformation of the point A_1 of the base; K_a and H_a are respectively stiffness and damping coefficients of the base.

Deformation of the point A_1 of the base is expressed as the distance from this point to the line through two points B_1 and B_2

$$D_1 = -[x_{A_1}(y_{B_2} - y_{B_1}) + y_{A_1}(x_{B_1} - x_{B_2}) + y_{B_1}(x_{B_2} - x_{B_1}) + x_{B_1}(y_{B_1} - y_{B_2})] / \sqrt{(y_{B_2} - y_{B_1})^2 + (x_{B_2} - x_{B_1})^2}$$

During alignment the body may contact the base at the point A_2 . Then normal reaction

$$N = -D_2 \cdot K_a - H_a \cdot \left(\sqrt{(y'_C)^2 + (x'_C)^2} \right)$$

where

$$D_2 = -[x_{A_2}(y_{D_2} - y_{B_2}) + y_{A_2}(y_{D_2} - y_{B_2}) + x_{B_2}(y_{B_2} - y_{D_2}) + y_{B_2}(y_{D_2} - y_{B_2})] / \sqrt{(y_{D_2} - y_{B_2})^2 + (x_{D_2} - x_{B_2})^2}$$

Numerical simulation was carried out under the following

parameters of the base: stiffness coefficient $K_a = 100$ and damping coefficient $H_a = 1$. Having values of reaction force N , motion equations of the movably based part have been numerically solved. Determined time dependencies of the mass center point coordinates x_C , y_C and tilt angle φ provide a possibility to evaluate the character of the parts alignment process.

Initially, due to positioning errors, coordinates of the movable part points B_1 and B_2 are displaced by particular value relative to the coordinates of points A_1 and A_2 of immovable base, which represents the part with a slot. Varying misalignment value, positioning errors influence on the process of the alignment was determined. The influence of joining clearance on characteristics of the alignment process was numerically simulated changing the A_1 and A_2 points' distance from the zero point of the coordinates.

Peculiarities of vibratory displacement of the parts and the influence of different parameters on the process of alignment were numerically simulated varying parameters of the dynamic system and excitation.

Based on numerical simulation results parts alignment duration dependencies on initial pressing force, friction coefficient, joining clearance, tilt stiffness parameter and excitation parameters were obtained.

Example graphs, illustrating the change of the generalized coordinates x_C , y_C , φ of the body and normal pressing force n , are presented in Fig. 5.

Initially axes of the components are misaligned, as $x_C(0) = 0.2$ and insertable body is slightly tilted by small angle $\varphi(0) = 0.001$ (Fig. 5, a, c). Kinematically excited body displaces over the base towards the axes matching direction, since x_C coordinate diminishes (Fig. 5, a). Thus, the bodies tilt angle φ increases and therefore, the coordinate y_C of the mass center diminishes. Normal pressing force n changes during the displacement. When the body falls into the slot, force n suddenly drops to zero (Fig. 5, d). This moment is fixed as alignment time. Those graphs have been obtained under joining clearance $\delta = 0.09$. Therefore, at the moment of falling into the slot, the body is tilted by a small angle.

The obtained simulation results showed that considerable influence on the process of alignment has force f_0 of the body pressing to the base. When the mentioned force acts, the body slightly tilts relative to the base and, therefore, horizontal component of the normal force n emerges, which predetermines vibratory displacement of the body. Vibratory displacement of nonlinear system may occur only if asymmetry exists. If the body is tilted even by a small angle, force asymmetry of the system exists and also emerges kinematical excitation of the body.

Under inconsiderable initial pressing force ($f_0 < 2$) and smaller tilt stiffness ($k_\varphi = 5-7$), directional displacement and tilt of the movably based part appears more slowly (Fig. 6). Increasing the initial pressing force, alignment duration diminishes. At higher values of the tilt stiffness k_φ ($k_\varphi = 10-20$) and small initial pressing force ($f_0 < 2$), duration of parts alignment initially decreases,

whereas later, within small range of f_0 values, increases and later again starts diminishing.

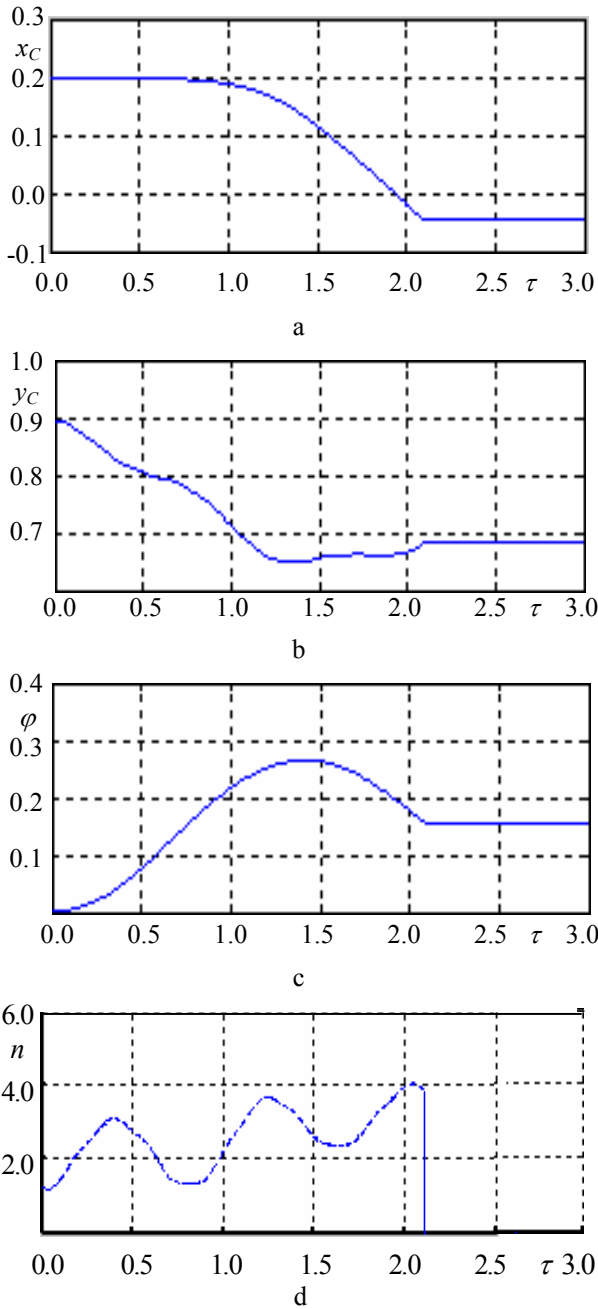

Fig. 5 Graphs illustrating generalized coordinates change: a – $x_c(\tau)$; b – $y_c(\tau)$; c – $\varphi(\tau)$; d – $n(\tau)$

For higher values of the tilt stiffness, alignment occurs only within limited range of the parameter f_0 . This is seen from graphical dependencies $\tau = f(f_0)$, as $k_\varphi = 10$, and $\tau = f(f_0)$, as $k_\varphi = 20$. Hence vibratory alignment occurs only as the values of parameters f_0 and k_φ are matched (Fig. 6).

Alignment duration dependencies on friction between contacting parts under different pressing force are presented in Fig. 7. Under different values of the friction coefficient μ , below 0.1, alignment duration increases more rapidly than under higher values of the friction.

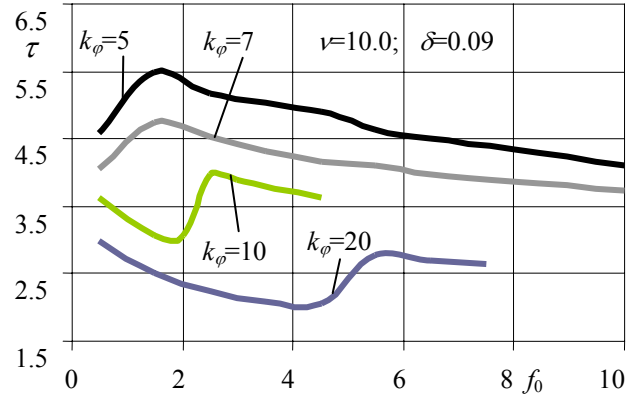

Fig. 6 Dependencies of parts alignment duration on initial pressing force f_0 under different values of the tilt stiffness parameter k_φ

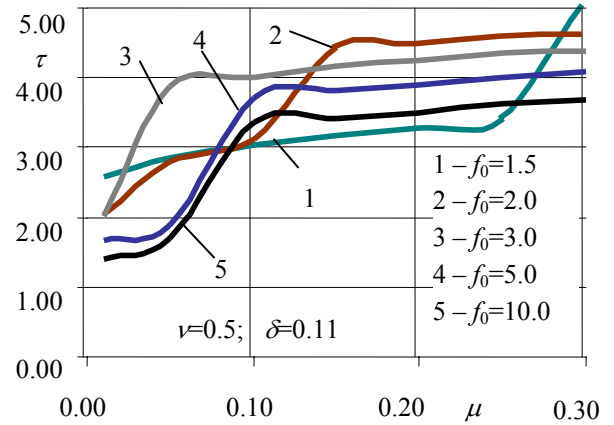

Fig. 7 Dependencies of parts alignment duration on friction coefficient μ under different values of the initial pressing force f_0

Under acting particular magnitude pressing force f_0 and small values of the tilt stiffness coefficient k_φ (Fig. 8), movably based body is able to turn relative to the base by such an angle, that part alignment does not occur. Under higher values of the parameter k_φ , the body tilts by smaller angle, but alignment is more intensive. Alignment intensity increases because of initial preload of the system, as a result of the initial pressing force. Due to existing preload, relative to the center of mass, emerges elastic restoration moment, which assists to align the body relative to the slot. If action, predetermining directional displacement, overcomes both the influence of friction and elastic resistance forces, then matching of the being assembled components may still occur. If forces, which predetermine directional displacement and turn, are equal to the resistance forces, matching gets impossible.

Excitation frequency ν influences duration of the parts alignment process. When $\nu < 10$, reliable alignment of the parts takes place within more wide value range of the tilt stiffness k_φ (Fig. 8). Graphs show, that the area of reliable alignment depends on excitation frequency. Therefore, it is necessary to match excitation frequency and angular stiffness.

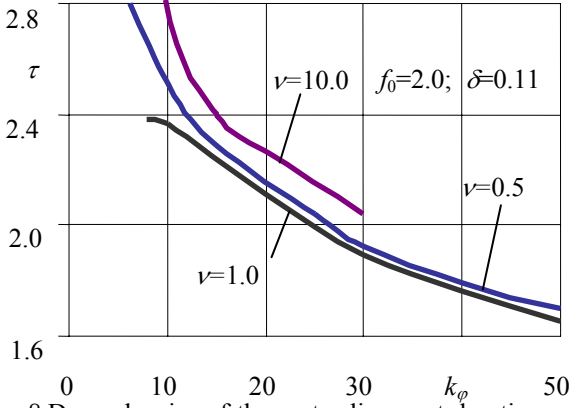

Fig. 8 Dependencies of the parts alignment duration on tilt stiffness parameter k_φ under different excitation frequency ν

The dependencies of the body alignment duration on tilt stiffness coefficient k_φ under different pressing force (Fig. 9) also show the dependence of alignment duration on tilt angle of the body relative to the base. The alignment of slightly pressed ($f_0 = 1$) and because of existing misalignment tilted body relative to the base slot under smaller tilt stiffness coefficient ($k_\varphi = 10-15$) has relatively long duration. Increasing the tilt stiffness coefficient k_φ , tilt angle of the movably based part is smaller and changes marginally during the alignment, whereas duration of the alignment process is diminishing.

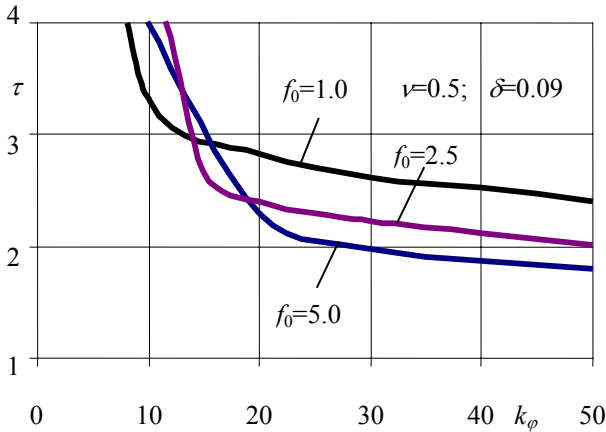

Fig. 9 Dependencies of the parts alignment duration on tilt stiffness parameter k_φ under different initial pressing force f_0

Under higher values of the initial pressing force ($f_0 = 2.5-5$) and small tilt stiffness, the effect, which predetermines directional displacement of the part is marginal, so alignment of the parts has longer duration. As $k_\varphi < 10$, alignment does not occur. Increasing the tilt stiffness coefficient k_φ , duration of the parts alignment initially significantly decreases, but later the decrease in duration is not so intense, but, under higher values of the initial pressing force, the influence of parameter k_φ on the duration of parts alignment is more apparent, than that for smaller values of the initial pressing force (Fig. 9).

The dependencies of the body inertia moment I_φ , relative to its center of mass, on duration of parts alignment are shown in Fig. 10. The moment I_φ depends both on the mass of the body and dimensions $2A$ and $2B$. Tilt resisting moment $I_\varphi \ddot{\varphi}$ of the body is proportional to the moment of inertia of the body. Therefore, as I_φ increases, because of higher tilt resisting moment of the body, alignment duration increases.

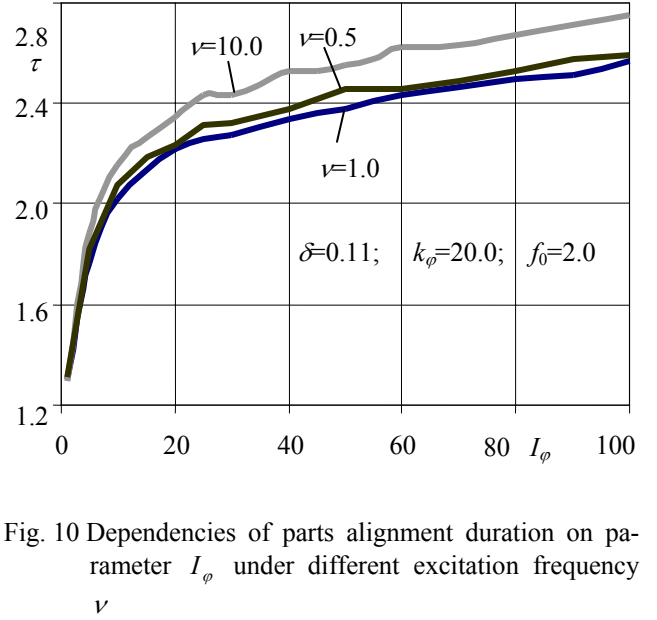

Fig. 10 Dependencies of parts alignment duration on parameter I_φ under different excitation frequency ν

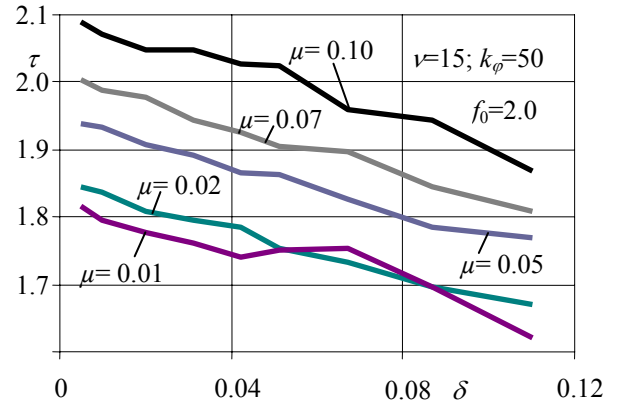

Fig. 11 Dependence of parts alignment duration on joining clearance δ under different friction coefficient μ

The dependencies of parts alignment duration on joining clearance δ are almost linear (Fig. 11). Here joining clearance is defined as

$$\delta = \frac{L - A}{A}$$

where A is half-width of the insertable part; L is half-width of the slot (Fig. 4).

Dry friction force, preventing displacement of the body, is proportional to the friction coefficient μ . Therefore, as friction force increases, alignment duration also increases.

Dependencies of alignment duration on pressing

force may have well-defined minimum (Fig. 12). The graphs in this figure are rather different from analogical graphs presented in Fig. 6. The dependencies $\tau = f(f_0)$ from mentioned figures have been made under different excitation frequency. The graphs given in Fig. 6 were obtained as excitation frequency $\nu = 10$. This means that the mentioned frequency is 10 times higher than partial frequency of characteristic vibrations of the system along y axis direction. Whereas dependencies, presented in Fig. 12, have been made as excitation frequency $\nu = 0.5$. This means, that the system was excited by a twice lower frequency, than the partial frequency. Therefore, in one case the system is excited by significantly higher frequency than resonant partial frequency of the system. In the other case, excitation frequency is below mentioned resonant frequency of the system. This leads to a conclusion, that excitation frequency must be properly chosen and matched with the pressing force.

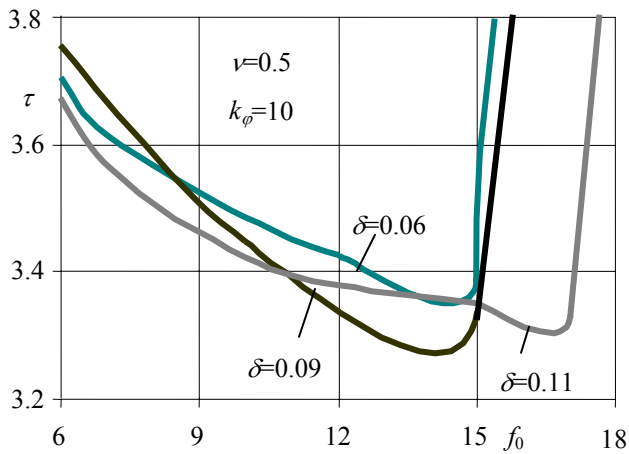

Fig. 12 Dependence of the parts alignment duration τ on initial pressing force f_0 under different joining clearance δ

The presented simulation results show, that vibratory alignment of the body takes place only under properly matched parameters of the system and excitation. For practical application of the obtained investigation results, it is necessary to determine sets of the mentioned parameters, when stable process of alignment is taking place. Such areas of parameters sets are given in Figs. 13, 14. Having determined mentioned areas, e.g., by the value of tilt stiffness coefficient k_ϕ of the locating elastic elements from the unhatched area, it is possible to determine values of the initial pressing force f_0 and excitation frequency ν , for the process of alignment to be stable. This is especially important performing design of vibratory assembly devices.

Performed analysis of the obtained results leads to a conclusion that properly chosen and interdependently matched both the parameters of dynamic system and excitation ensure reliable and fast matching and joining of peg-hole type parts being assembled automatically.

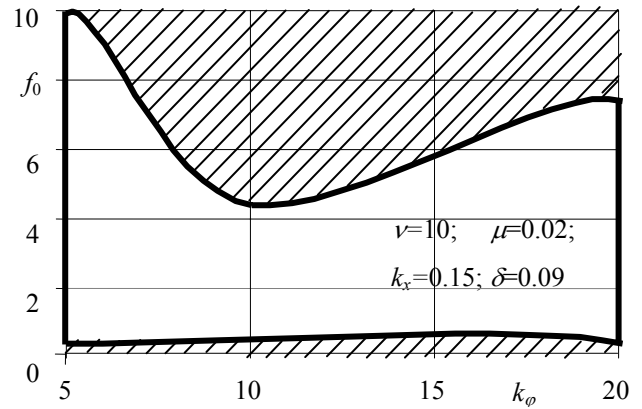

Fig. 13 Area of stable alignment of the parts (unhatched) depending on parameters k_ϕ and f_0

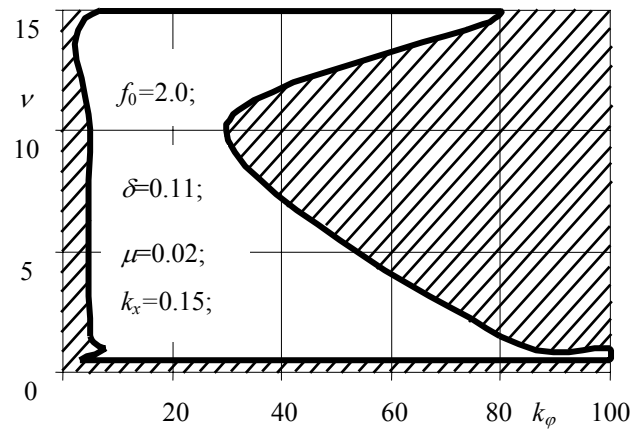

Fig. 14 Area of stable alignment of the parts (unhatched) depending on parameters k_ϕ and ν

4. Conclusions

1. It was determined by numerical simulation, that vibratory alignment requires particular selection of the initial pressing force of the components. Reliable alignment of the components occurs as initial pressing force $f_0 \leq 10$. Magnitude of the pressing force, predetermining minimal alignment duration, depends on excitation frequency of the movably based component along the assembly direction.

2. Significant influence on the character of the alignment process has tilt stiffness of the movably based component. Alignment of the parts requires tilt stiffness to be smaller than 10. Increasing tilt stiffness, alignment duration decreases. Peak value of the tilt stiffness, under which alignment takes place, depends on excitation frequency.

3. It was determined, that at excitation frequencies, smaller or equal to the partial frequency of natural vibrations of the system along y direction, vibratory displacement occurs in more wide range of the tilt stiffness values, if compared to that under higher excitation frequencies.

4. The influence of the tilt stiffness k_ϕ on parts alignment duration depends on the initial pressing force and is stronger under higher values of the pressing force.

5. As coefficient of dry friction μ between the contacting components increases, alignment duration non-uniformly increases and its variation character depends on the component pressing force. An increase in alignment duration is significant as $\mu \leq 0.15$, pressing force $f_0 < 3$.

6. Alignment duration is inversely proportional to the joining clearance. Character of those dependencies is almost linear and slightly depends on friction coefficient.

7. Areas of main parameters sets were determined, i.e. initial pressing force f_0 , tilt stiffness k_φ and excitation frequency ν , in $f_0 - k_\varphi$ and $\nu - k_\varphi$ planes, where alignment is taking place. By those areas, it is possible to determine reasonable engineering and excitation parameters during vibratory devices development.

8. Properly chosen and matched dynamic system and excitation parameters ensure reliable and fast peg-hole parts alignment during automated assembly.

References

1. **Dashchenko, A. I., Ludwig D., Dashchenko O.** Assembly automation – the way to a factory of the future. -Emerging Technologies and Factory Automation, 1995.-WFTA '95, Proc., 1995 INRIA/IEEE Symp., 10-13 Oct, 1995.-v.2, p.259-267.
2. **Sudsang A., Kawraki, L.** Part orientation with a force field: Orienting multiple shapes using a single field.- IROS 2001, Oct 29-Nov 3, MAUI, IEEE/RJS proc. of Int. Conf. on Intelligent Robots and Systems, 2001, v.1, p.208-213.
3. **Henneken V., Tichem M., Karpuschewski B.** Exploring the benefits of MEMS for micro assembly tasks.- Assembly Automation, v.24, n4, p.416-421.
4. **Leu, M.C., Katz Z.** Vibration assisted engagement for parts mating.-CIRP Annals, 1994, 43(1), p.27-30.
5. **Leu, Ming C., Liao H.** Parts mating aided by constant amplitude sinusoidal motions.-Journ. of manufacturing science and engineering, 1999, v121, n4, p.802-810.
6. **Leu, Ming C., Liu, Y.** Modeling and analysis of parts mating in vibration assisted compliant assembly.-3-rd ASME Conf. on Flexible Assembly Systems, Sep. 22-25, Miami, USA, 1991.-ASME, New York, Design Engineering Division DE, v33, p.9-20.
7. **Li, Shih-Hung, Asada, H.** Automated robotic assembly using a vibratory work table: optimal tuning of vibrators based on the Taguchi method.-Flexible Automation, 1992, p.1531-1538.
8. **Kang, E.S., Cho, H.S.** Vibratory assembly of prismatic parts using neural network-based positioning error estimation.-Robotica, v13, n2, 1995, p.185-193.
9. **Lee, Sooyong, Asada H.** Assembly automation using vibratory end-effector: Modeling and stability analysis.-IEEE Proc. of Int. Conf. on Robotics and Automation, 1997, v3, p.1980-1985.
10. **Bakšys, B., Baskutienė, J., Povilionis, A.B.** Experimental investigation of parts vibratory alignment under kinematical excitation. -Mechanika. -Kaunas: Technologija, 2005, 6(56), p.27-32.
11. **Bakšys, B., Baskutienė, J., Povilionis, A.B.** Experimental investigation of parts vibratory alignment exciting immovably based part. -Mechanika.-Kaunas: Technologija, 2006, 3(59) p.42-48.

B. Bakšys, J. Baskutienė

DETALIŲ CENTRAVIMO MODELIAVIMAS ESANT KINEMATINIAM ŽADINIMUI

R e z i u m ė

Straipsnyje nagrinėjamas veleno-įvorės tipo detalių centravimas kinematiškai žadinant velenėlių. Sudarytas matematinis modelis besmūgiam detalių centravimo režimui. Gautos grafinės detalių centravimo laiko priklausomybės nuo pradinio prispaudimo jėgos, posūkio standumo, sujungimo tarpelio, trinties koeficiento bei žadinimo dažnio. Nustatytos parametrų derinių sritys, kur veleno-įvorės detalių centravimas yra stabilus ir patikimas. Tinkamai suderinus dinaminės sistemos ir vibracinio žadinimo parametrus galima patikimai centruoti detales robotizuoto rinkimo metu.

B. Bakšys, J. Baskutienė

NUMERICAL SIMULATION OF PARTS ALIGNMENT UNDER KINEMATICAL EXCITATION

S u m m a r y

This paper deals with peg-hole parts alignment under kinematical excitation of the peg. Mathematical model for nonimpact regime of parts alignment was made. Graphical dependencies of alignment duration on initial pressing force, tilt stiffness, friction coefficient and excitation frequencies were obtained. The areas of parameters sets were determined for stable and reliable alignment of the parts. Properly chosen parameters of dynamical system and vibratory excitation allow reliable alignment of the parts during robotized assembly.

Б. Бакшис, Й. Баскутене

МОДЕЛИРОВАНИЕ ЦЕНТРИРОВАНИЯ ДЕТАЛЕЙ ПРИ КИНЕМАТИЧЕСКОМ ВОЗБУЖДЕНИИ

Р е з ю м е

В статье анализируется центрирование деталей типа вал-втулка при кинематическом возбуждении подвижно базируемого валика. Составлена математическая модель для безударного режима центрирования. Получены графические зависимости продолжительности центрирования деталей от силы поджима, угловой жесткости, зазора соединения, трения и частоты кинематического возбуждения. Выявлены области сочетаний параметров для стабильного и надежного центрирования. Согласование параметров динамической системы и вибрационного возбуждения способствует надежному центрированию деталей при роботизированной сборке.

Received April 28, 2007

DOI: 10.5755/j02.mech.14837