

Theoretical background of automated packaging machines when closing a package with metal clips

L. Paulauskas

Kaunas University of Technology, Kęstučio 27, 44312 Kaunas, Lithuania, E-mail: lionginas.paulauskas@ktu.lt

1. Introduction

Packaging materials, which directly contact with food products must possess chemical resistivity, have certain physical, chemical, mechanical and technological, meet hygiene requirements and assure high automatization level of the packaging process

For packaging of smoked, boiled, liver sausage-meat of mechanical filling, also butter, curd, diet curd, curd for children, sour-cream, ice-cream mass and similar consistence products, one of the ways is packaging into various size bar-type film packages closing their ends by metal clips. For this reason film packaging materials made of protein belkozin, polymer povidene and polyethylene are used which are suitable for packing the different product brands according to hygiene, technological and technical requirements [1, 2].

When packaging the products into bar-type packages, internal surfaces of packaging material contact the product and that troubles or totally prevents the proper closing of the package ends using traditional methods like welding, gluing etc. In such case the best solution is closing the package ends with metal clips [3].

Although clip formation and its putting on the package end is one of the major operations performed by the automated packaging machine, it is not yet investigated.

It is reasonable to control packing mechanisms of packaging automated machines by leverages. They are simple, easy to manufacture, comfortable and reliable in use. It is complicated to design packaging automated machines with optimal parameters if their comprehensive kinematical and dynamic characteristics are not known.

Kinematic investigations of different models are performed by the method of vector contours, which was theoretically proved by prof. V. Zinovjev [4].

2. Package closing mechanism modules with five-bar mechanisms

Fig. 1 presents basic schemes of the developed closing modules of automated packaging machines. Kinematic and vector contour schemes of the basic module are presented in Fig. 2.

Driving links 2 and 3 of the mechanism are joined by the gear couple of external meshing. One of the gears, e.g. No. 6, is joined with the driving shaft of the mechanism. Gears 6 and 7 have the same diameter and the same number of teeth, thus angular velocity of link 3 is equal to the angular velocity of link 2, just the directions of rotation differs, i.e.

$$\omega_2 = -\omega_3$$

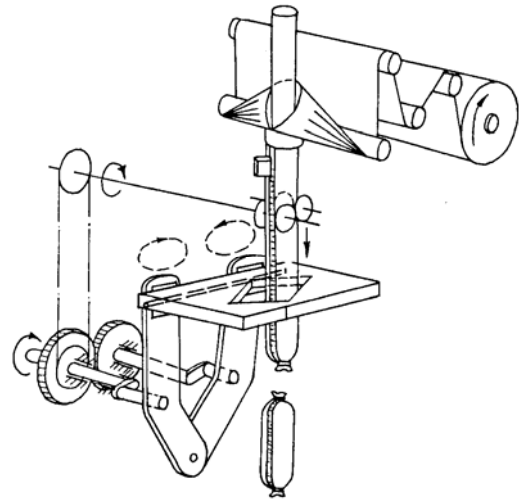

a

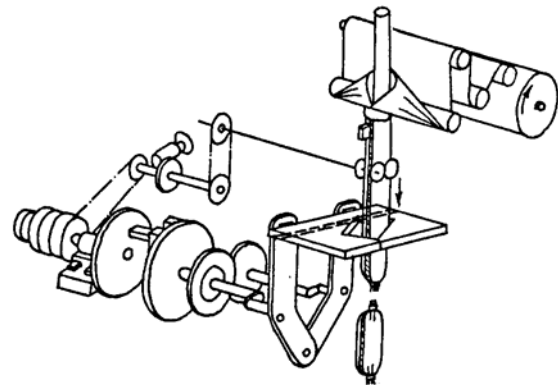

b

Fig. 1 Basic schemes of the automated packaging machines for packing of the products into film packages closing the package ends with metal clips: a - basic scheme; b - a coulisse for controlling the five-bar mechanism

There are points D and F on the driven couplers 4 and 5, which generate coupler point curves and perform working movements when the mechanism moves. In the points D and F the package closing operation modules for closing the package ends with metal clips or welding the sleeve-shaped films from the thermally welded packaging band are fixed.

Fig. 2, b presents vector contours of package closing module of automated packaging machines. This is a plane five-link mechanism with two driving links.

Projecting the vector contour O_1OACO_1 to the X axis, we obtain

$$S = l_0 + l_2 \cos \varphi_2 - l_3 \cos \varphi_3 \quad (1)$$

dynamic moment, which appears on the rotating driving shaft due to inertia forces of its driven links.

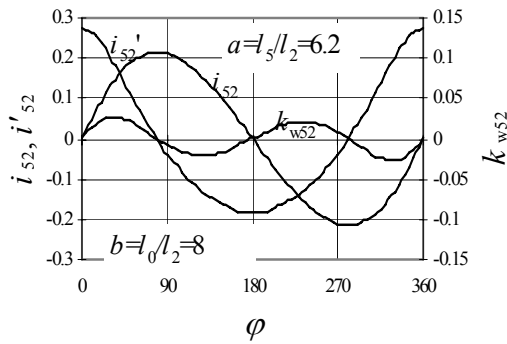

Fig. 3 Kinematic characteristics of the link 5 of five-bar mechanism

According to the calculations and obtained dynamic characteristics it can be stated that in the case when partial delay has an influence on the mechanism operation and package quality, especially when shaping the packages of bigger length, mechanism structure and basic scheme must be supplemented by new structural elements.

3. Module of five-link coulisse controlled package closing mechanism of automated packaging machines

Packages of different dimensions and mass must be produced by an automated packaging machine. Thus taking into account operation conditions, the velocity of motion of the package shaping mechanism must be increased or decreased, in this way increasing or decreasing the package length [3, 4]. For such velocity regulation it is recommended to use coulisse mechanisms. The basic scheme of such mechanism is shown in the Fig. 1, b.

In the kinematic scheme shown in the Fig. 4, the driving shaft of the link 2 is connected to the coupling. It is characteristic to such kind of device that it has the before investigated five-bar package closing mechanism, and only for its control an additional coulisse coupling is used, which provides new kinematic and dynamical characteristics for the mechanisms of the automated packaging machines.

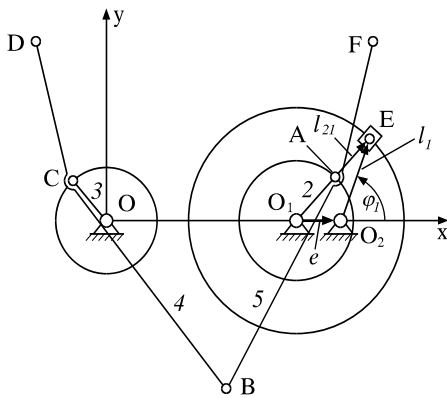

Fig. 4 Kinematic scheme of five-bar mechanism for package closing with coulisse coupling

Shifting the axis of shaft 1 with respect to the axis of shaft 2 in one or another direction, the velocity of mo-

tion of package closing mechanism can be governed.

Joining the coulisse mechanism with the package closing mechanism, as it is shown in the Fig. 4, we obtain the mechanism with two contours. Kinematic calculations of both contours are more convenient to be done separately.

Projecting the vector contour $O_2O_1EO_2$ to the coordinate axes and using the before described methodics we obtain the velocity analogues

$$i_{21} = \frac{l_1}{l_{21} \cos(\varphi_2 - \varphi_1)} \tag{12}$$

And the analogues of angular acceleration are

$$i'_{21} = \frac{i_{21}^2 l_{21} \sin(\varphi_2 - \varphi_1) + 2(V_{E_2E_1})_{\varphi_1}}{l_{21} \cos(\varphi_2 - \varphi_1)} \tag{13}$$

Joining the coulisse mechanism with five-link package closing mechanism shown in the Fig. 4 the system of equations with respect to the generalized coordinate φ_1 , when $\omega_1 = const$, can be obtained. Also, if the solutions for different mechanisms are known, the equations derived for a multilink mechanism can be used.

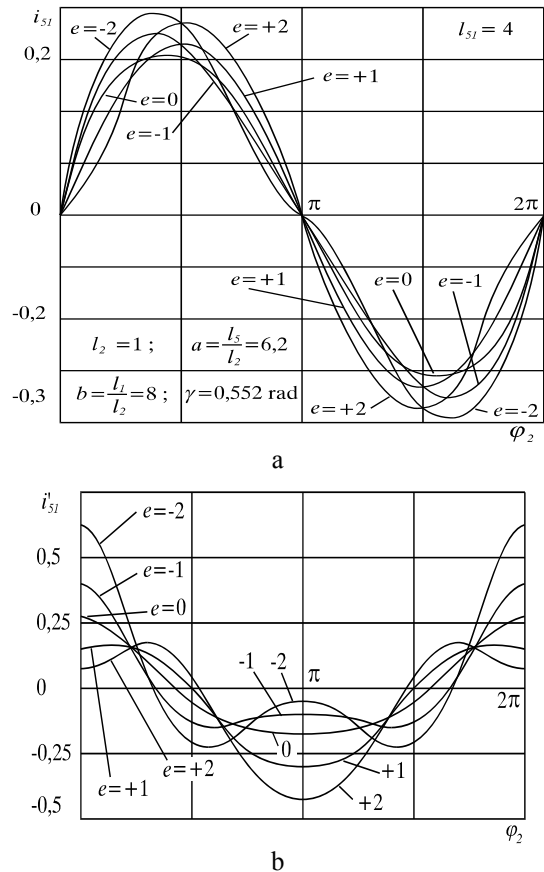

Fig. 5 Kinematic characteristics of the package closing five-bar mechanism with additional coulisse coupling

Velocity analogues for the driven links 4 and 5 are

$$\left. \begin{aligned} i_{51} &= i_{21} i_{52} \\ i_{41} &= -i_{51} \end{aligned} \right\} \tag{14}$$

The acceleration analogues of the same links are

$$\left. \begin{aligned} i'_{51} &= i_{21}^2 i_{52} + i'_{21} i_{52} \\ i'_{41} &= -i'_{52} \end{aligned} \right\} \quad (15)$$

The main characteristics of coulisse couplings connected to the main mechanism, the structure of which is shown in the Fig. 4, are represented in the Fig. 5, a and b. At calculations it is assumed that $l_{21}=4$, and the eccentricity is varied from +2 to -2. When designing a coulisse, coupling length l_{21} is chosen and the necessary eccentricity is then found out.

It can be seen that the driven link velocity analogues vary smoothly, when eccentricity changes from +2 to -2. Angular acceleration analogue changes quite much depending on e .

Providing a mechanism with constant angular motion, it is noticed that only packages of a certain length can be closed using it. Mean package closing velocity in the closing zone must be equal to the sleeve extrusion velocity. According to this condition the package length is $L = 2\pi l_2 i_{21} \nu$, where l_2 is length of a link 2; i_{21} is coulisse transmission ratio, when $\varphi_2 = 180^\circ$; ν is coefficient of velocity uniformity.

In order to fill up packages of the length greater than L_{maks} a mechanism must be stopped during every cycle, at the same time keeping the uniform extrusion of packaging band. Stopping pause duration will be proportional to the package length ΔL .

4. Conclusions

1. By employing a coulisse for controlling the five-bar mechanism new kinematic and dynamical characteristics of the mechanism can be achieved. By changing the magnitude of coulisse coupling eccentricity e the package length of packaging mechanism can be governed in an even manner.

2. In order to obtain packages of the length greater than L_{maks} the mechanism must be stopped during every cycle, at the same time keeping the uniform extrusion of packaging band. Stopping pause duration will be proportional to the package length ΔL .

References

1. **Stoermer, A., Franz, R.** Assuring conformity of packaging materials with the European food regulatory requirements. -New Food 4, 2001, p.84-87.
2. **Weyer, K.** The future of packaging. -New Food 4. 2001, p.94-95.
3. **Paulauskas, L.** System of automated packaging machines when closing a package with metal clips.-

Mechanika. -Kaunas: Technologija, 2007, Nr.2(64), p.56-60.

4. **Zinovjev, V.A.** Mechanisms and Machine Theory.- Moscow, 1992. -384p. (in Russian).

L. Paulauskas

METALINĖMIS SAVARŽOMIS PAKUOTES
UŽDARANČIŲ PAKAVIMO AUTOMATŲ TEORINIAI
PAGRINDAI

R e z i u m ė

Straipsnyje pateikti pakavimo automatų produktams fasuoti į plėveles, užspaudžiant pakuočių galus metalinėmis sąvaržomis, teoriniai pagrindai. Pateiktos sukurtos naujos pakavimo technologijos, pakavimo automatų principinės schemos, šių automatų kinematinė ir dinaminė charakteristikų skaičiavimo metodika.

L. Paulauskas

THEORETICAL BACKGROUND OF AUTOMATED
PACKAGING MACHINES WHEN CLOSING A
PACKAGE WITH METAL CLIPS

S u m m a r y

Theoretical background of package closing modules for automated packaging machine are worked out. The developed technology, methodics and new principal solutions with the methods for their calculation and optimization, kinematic and dynamical characteristics of these mechanisms and new structures are presented.

Л. Паулаускас

ТЕОРЕТИЧЕСКИЕ ОСНОВЫ УПАКОВОЧНЫХ
АВТОМАТОВ ЗАКРЫТИЯ УПАКОВОК
МЕТАЛЛИЧЕСКИМИ СКРЕПКАМИ

Р е з ю м е

В статье представлены теоретические основы упаковочных автоматов для упаковки продуктов в пленку закрывая концы упаковок металлическими скрепками. Представлены принципиальные схемы новой технологии упаковочных автоматов, методика расчета характеристик кинематики и динамики автоматов

Received May 8, 2007

DOI: 10.5755/j02.mech.14840