

Research of force drives of the production gear hobbing machine with CNC

V. Gichan*, K. Slivinskas**, V. K. Augustaitis***

*Vilnius Gediminas Technical University, J. Basanavičiaus 28A, 03224 Vilnius, Lithuania, E-mail: Vladimir@zebra.lt

**Vilnius Gediminas Technical University, J. Basanavičiaus 28A, 03224 Vilnius, Lithuania, E-mail:

Kastytis.Slivinskas@me.vgtu.lt

***Vilnius Gediminas Technical University, J. Basanavičiaus 28A, 03224 Vilnius, Lithuania, E-mail: pginas@me.vgtu.lt

1. Introduction

One of the ways to increase the productivity of gears production in job shop is the usage of a CNC gear hobbing machine [1]. In the case of production of gears using gear hobbing, the economics of the production process restricts cutting in and cutting off stages of the cutting cycle. These stages last comparatively a long time during which not all power possible is used – the power reaches the rated power only when all teeth of the hob being in contact with the workpiece are cut in on the full predetermined depth. The length of the travel stage from the first contact of the hob with the workpiece till the moment of usage of the rated power required for full depth cutting is big enough and together with the cutting off stage consists of 80-100% of the width of the workpiece in most cases.

Methods exist [2], where forced cutting in feed is used instead of an accepted cutting-indexing cycle feed, during which the axial feed is increased significantly, and the hob axis motor reaches the possible rated cutting power. After reaching a particular cutting depth, the forced feed is switched off leaving the indexing process only, and when the workpiece will make a full turn, the forced feed is switched on for the next time, and the cutting cycle is repeated. A similar hobbing method is used for the cutting off stage.

2. Modification of the forced cutting process using CNC gear hobbing machine

Modification of the forced cutting process is possible using CNC Machine for gear hobbing. This allows various combinations of axial feed-indexing motions, which help to improve process efficiency.

The time moment of switching on or switching off of the forced feeding can be determined by using the closed loop according to the hob axis motor power used. Using the pulse type feed during cut in (cut off) stages, the indexing process also takes place during the forced feeding and the point of angular position on the workpiece surface at the end of the forced feeding overruns the angular position of the first contact point of the hob and workpiece. So, the position of switching on of each forced feed motion changes.

The hob tooth cutting edge trace in the workpiece is composed of three additives created due to three relative motions [3, 4]: the rotation of the hob around its axis, indexing motion between the hob and the workpiece, and axial feeding. These motions can be divided into two pairs, which determine the thickness of the chip cut: the first pair

is the hob rotation together with axial feeding motion and the chip is cut due to axial feeding, the second one is the hob rotation together with indexing motion and the chip is cut due to indexing motion. The first pair just determines the forced feed power, and the second one determines the biggest part of power, which is used during conventional hobbing.

As an example of the graphs of the hob motor loading, axial feed of the hob and control commands to switch on and switch off axial feed in the start of hobbing are shown in Fig. 1.

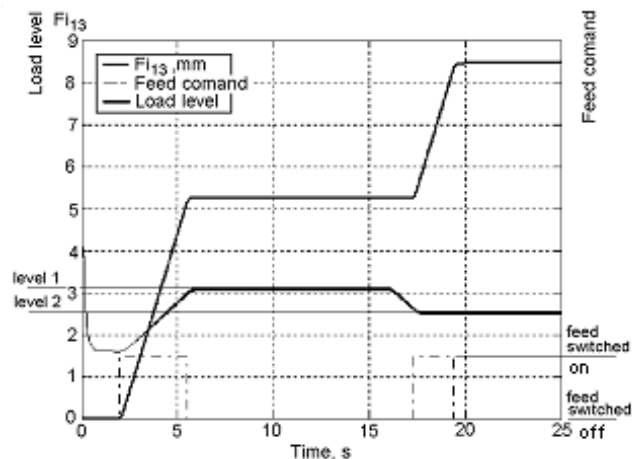

Fig. 1 Graphs of loading the hob motor, axial feeding (F_{13}), and commands of switching on and switching off the feed during time at initial hobbing

The load on the hob is determined by measuring electrical power (active power) used by the hob motor. Such a method of determination of the load on the tool is rather simplified. However, the practice shows that it gives sufficiently good results. As Fig. 1 shows, just after switching on the hob motor its power consumed increases sharply till the motor reaches the predetermined speed, then the power used decreases and remains on the level corresponding to the load required for idle rotation of the hob spindle axis.

When the feed is switched on, the lead screw (F_{13}) pushes the hob in axial direction. When the hob starts to cut the chip, the load begins to increase. When the load reaches the predetermined level 1, the feed is switched off, but the workpiece and the hob continue rotation in synchronous way. Due to the cut in stops, the electrical load does not increase further and remains constant due to indexing motion. A horizontal zone is seen on the load graph, which lasts till the moment when the work-

piece point, at which the cutting process starts, reaches cutting zone and the load level starts to decrease. When the load drops till the preset level 2, the controller switches on the feed – the hob will start to continue travel in axial direction and the load stops to drop and then in dependence on the switched state duration will leave on the level 2 or will begin to increase again causing the controller to give command to switch off the feed. The increasing of the load stops. The process repeats.

In the gear hobbing machine axial shifting of the tool (hob) during hobbing process can also be used – in this case the full working length of the hob is exploited, cutting edges wear more evenly, and the gear teeth surface processed is obtained better.

Using the axial tool shifting during forced feeding, it is possible to decrease the angle of indexing on which the workpiece turns during the forced feeding and at the same time to reduce thickness of the chip cut due to

indexing, leaving more power for metal cutting due to forced feeding. The tool can be returned to its initial position along the shifting axis by switching the shifting in opposite direction during an ongoing conventional predetermined fool profile hobbing.

Such a control of all related axes is possible by using the CNC gear hobbing machine. At the same time the mentioned above process requires corresponding researches. One of them would be modelling of the described process.

3. Modeling of the force drives of the gear hobbing machine with CNC

The total number of CN controlled axes in such a machine can be 6 or more. Movements performed by using these axes must be linked in a corresponding way for obtaining particular parameters of the gear hobbled (Fig. 2).

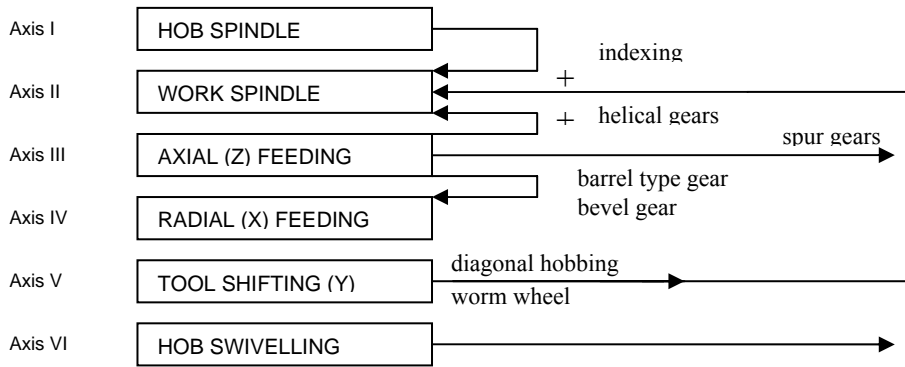

Fig. 2 Links between axes of CNC gear hobbing machine

With the aim to research the behavior of force drives during cutting process, dynamical model of the machine

including all axes, which take part in the force cutting, was created (Fig. 3) [5].

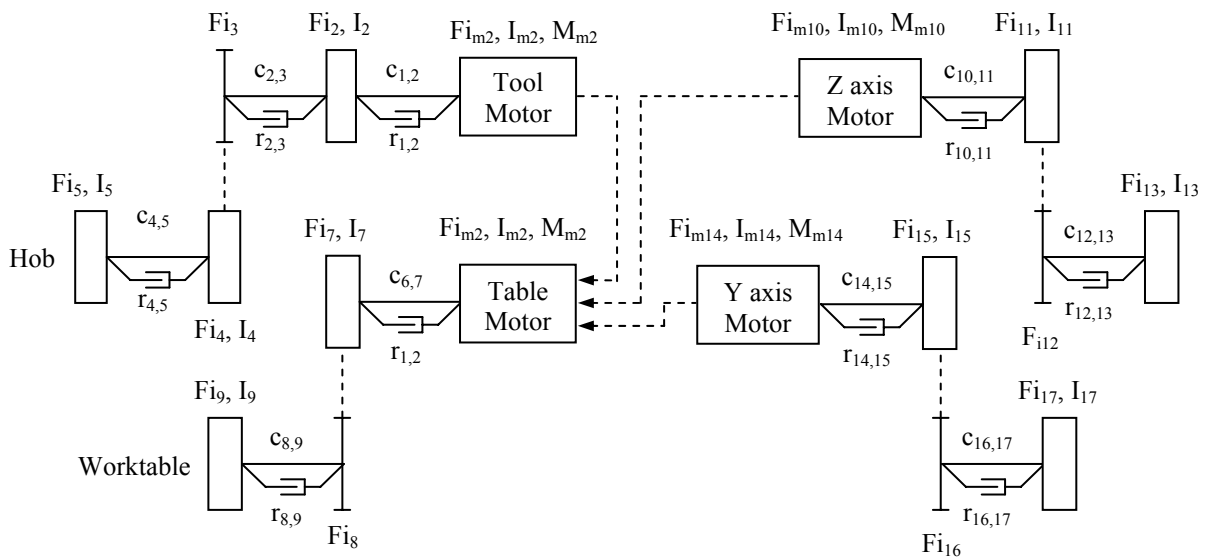

Fig. 3 Dynamic model of CNC gear hobbing machine

Here, the mechanical parts of CNC axes are introduced in more detail, as dynamic model elements. However, links between the drives of axes motors are shown only schematically – by dot lines. The model shows all mechanical elements, which were introduced in the model used for simulation.

The model for the simulation of gear hobbing process (SIMULINK diagram), comprising models of mechanical parts of axes, their motors, motor drives, electrical links between them, control system was designed.

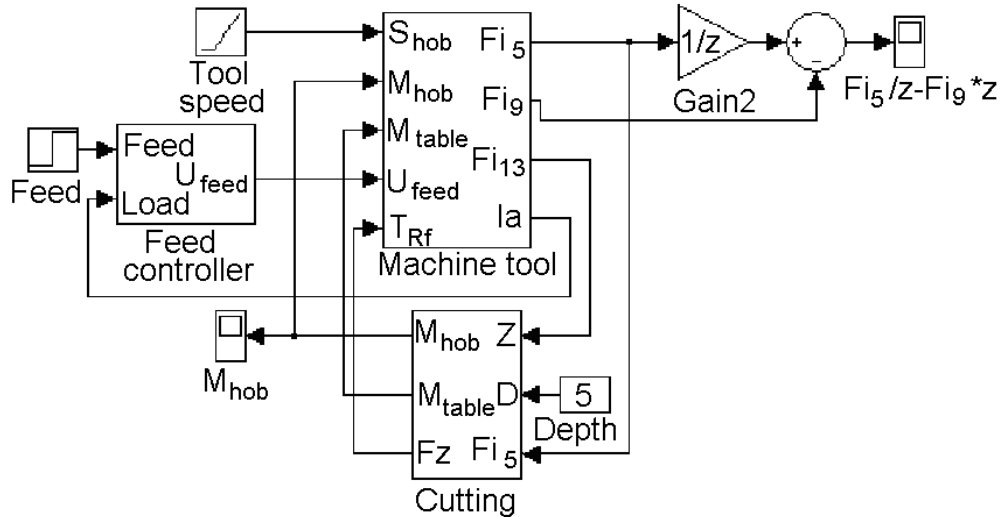

Fig. 4 The model (SIMULINK diagram) of CNC gear hobbing machine for cutting process modelling and the tool feed control simulation

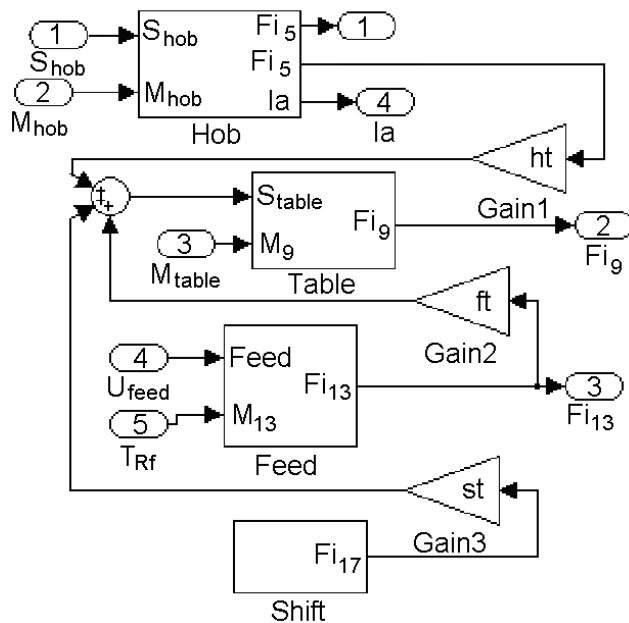

Fig. 5 The model (SIMULINK diagram) of machine axes introduced in the cutting process

The diagram (Fig. 5) allows modeling of the cutting force by varying two parameters influencing the cutting force: the value of axial feed and the cutting depth. So, the cutting force was modeled by evaluating axial feed

All constituent parts in the diagram for modelling are shown as corresponding blocs with indicating their inputs and outputs (Fig. 4).

The block which models the mechanical part of the hob axis is shown in detail way in [1].

The diagram shown in Fig. 4 includes the diagram shown in Fig. 5, which demonstrates relations between four axes: hob axis, table axis, axial feed axis, and the axis of the hob shifting.

velocity, the cutting depth, and actual rotational frequency of the hob spindle.

A more detailed model of the axial feed axis with corresponding outputs for the cutting force modelling is given in [1].

4. Examples of modelling

The cutting in stage of the gear hobbing process was modelled. The character of the cutting force (hob axis motor torque) changes during start of the cutting process is shown in Fig. 6.

Fig. 6 shows that the torque change characteristic allows obtain information in order to create the signal for controlling switching on or switching off the axial feed axis motor, as well as the shifting axis motor. The total kinematical error of the gear hobbing – the mismatch between the hob spindle and the workpiece spindle can be calculated by using the same SIMULINK modeling diagram shown in Fig. 4. The kinematical error of the hob-workpiece link gives the difference $F_{i5}/z - F_{i9}$ (in radians), where z is the number of teeth of the gear being cut. The mismatch of the hob and the workpiece during starting and after synchronizing, and character of the error are shown in Fig. 7.

The hob spindle axis has two frequencies, which could cause the resonance. But they are in a enough high frequency region and had no influence on our investigation.

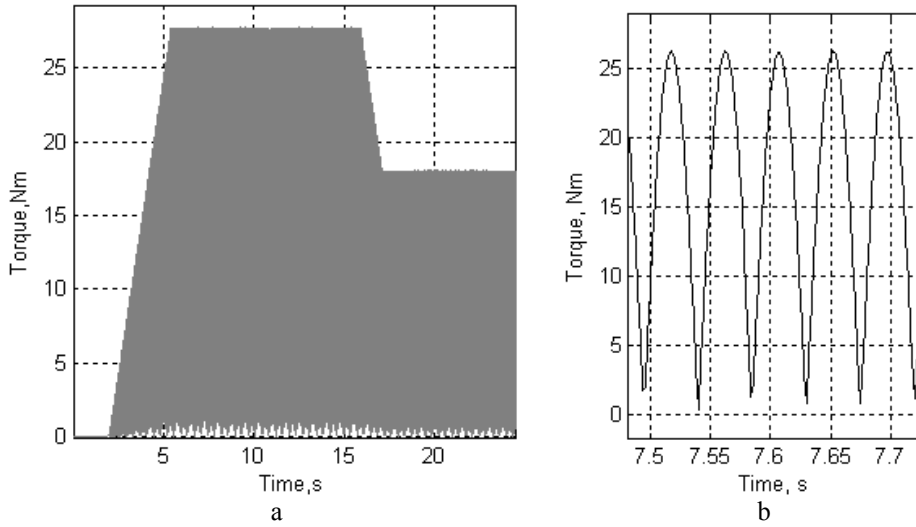

Fig. 6 Variation of the hob axis motor torque during cut in process: a - character of the total torque level change; b - variation of the torque with the frequency of the hob teeth changes

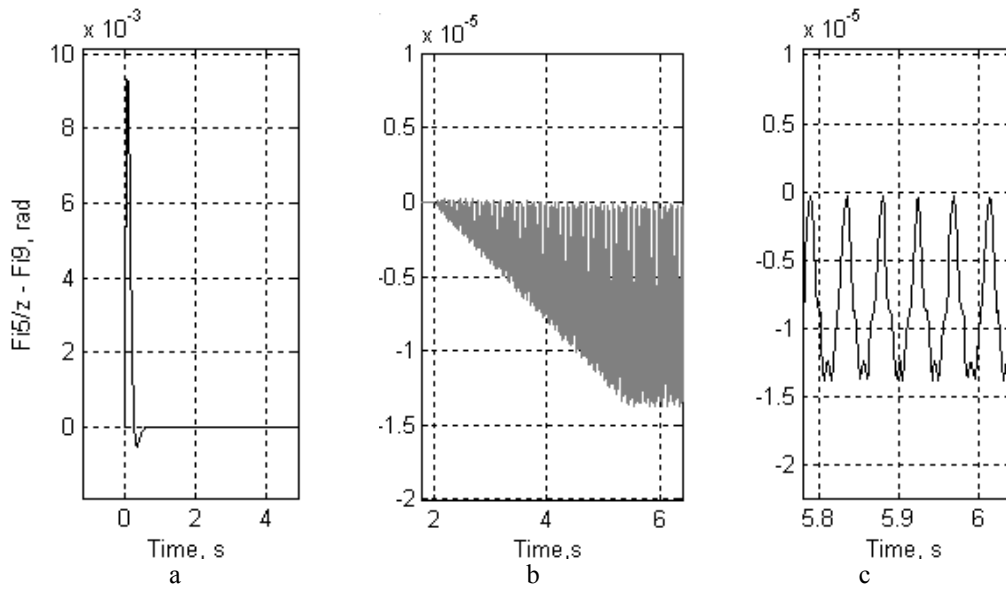

Fig. 7 Mismatch of the servo system between the hob axis and the table axis reduced to the table axis: a - during start; b - during forced cutting; c - error oscillation form

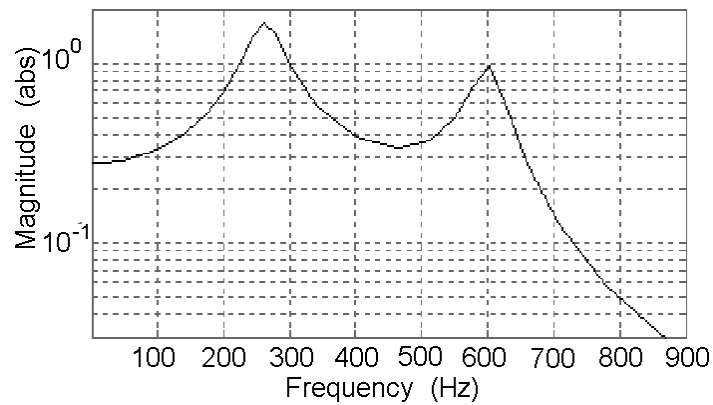

Fig. 8 Amplitude-frequency characteristics of the mechanical part of the hob spindle axis

5. Conclusions

1. The method of speeding up the time of cutting in and cutting off processes in forced gear hobbing with the CNC gear hobbing machine based on the corresponding control of the axial feed axis by creation of the pulse type axial feed and corresponding control of shifting axis is proposed.

2. The model for modeling of the cutting process, the dynamic model and the diagram for simulation are created and presented.

3. Examples of modelling of the cutting in stage of the gear hobbing process are shown. The same SIMULINK diagram is proper for calculating amplitude-frequency characteristics of the mechanical part of the machine.

References

1. **Slivinskas, K., Gichan, V. Poska, A. J. and Augustaitis, V.K.** Analysis of the possibilities of the usage of electrical synchronous link for a CNC gear hobbing machine.-Solid State Phenomena.-Trans Tech Publications Ltd, Switzerland, 2006, v.113, p.97-102.
2. **Fraimovitch, S., Lukashev, J., Gichan, V., Rozman, G.** SU patent No 944823. Method of the Feed Control during Gear Hobbing by Indexing Method, 1982.
3. **Sinkevichius, V.** Creating of the gear hobbing model. -Mechanika. -Kaunas: Technologija, 1997, Nr.4(11), p.51-60 (in Lithuanian).
4. **Sinkevichius, V.** Simulation of gear hobbing forces. -Mechanika. -Kaunas: Technologija, 2001, Nr.2(28), p.58-63 (in Lithuanian).
5. **Slivinskas, K., Augustaitis, V.K.** Algorithm of computer aided design of equations of motion for a complex mechanical system. -Mechanika. -Kaunas: Technologija, 2000, Nr.2(22), p.40-47.

V. Gičan, K. Slivinskas, V. K. Augustaitis

PRODUKČINIŲ KRUMPLIARAČIŲ FREZAVIMO CNC STAKLIŲ JĖGOS PAVARŲ TYRIMAS

Reziumė

Straipsnyje pateiktas metodas įsijavimo ir baigiamojo įsijavimo procesams paspartinti jėginio krumplių frezavimo CNC staklėmis metu. Metodas yra pagrįstas atitinkamu ašinės pastūmos ašies valdymu, sukuriant impulsinio tipo ašinę pastūmą šių procesų metu ir atitinkamai valdant įrankio ašinės pastūmos ašį.

Pateiktas dinaminis modelis ir jo pagrindu sukurta SIMULINK diagrama modeliavimui ir valdymo metodams tirti. Sukurtas modelis įgalina tirti jėgos, tikslumo ir valdymo priklausomybes. Pateikta jėginių pavarų modeliavimo pavyzdžių.

V. Gichan, K. Slivinskas, V. K. Augustaitis

RESEARCH OF FORCE DRIVES OF THE PRODUCTION GEAR HOBBING MACHINE WITH CNC

Summary

The method of speeding up the time of cutting in and cutting off processes in forced gear hobbing with the CNC gear hobbing machine is proposed. The method is based on corresponding control of the axial feed axis by creation of the pulse type axial feed during these processes and corresponding control of shifting axis. For modeling of the cutting process, the dynamic model and on the base of it the diagram for simulation and investigation of control methods were created and are presented here. The model created allows researching force, accuracy and control dependences. Examples of force drives modeling are shown, as well.

В. Гичан, К. Сливинскас, В. К. Аугустайтис

ИССЛЕДОВАНИЕ СИЛОВЫХ ПРИВОДОВ ПРОДУКЦИОННОГО ЗУБОФРЕЗЕРНОГО СТАНКА С ЧПУ

Резюме

В статье предложен метод ускорения процессов врезания и выхода при силовом зубофрезеровании на зубофрезерном станке с ЧПУ. Метод опирается на определенном управлении оси осевой подачи, создавая импульсную осевую подачу во время этих процессов и определенном управлении оси шифтинга. Для моделирования процесса резания была создана и представлена динамическая модель и на ее базе СИМУЛИНК разработана диаграмма для моделирования и исследования методов управления. Созданная модель позволяет исследовать силовые, точностные зависимости и зависимости управления. Приведены примеры моделирования силовых приводов.

Received December 17, 2007

DOI: 10.5755/j02.mech.14939