

Tractor ballasting in field work

A. Janulevičius*, K. Giedra**

*Lithuanian University of Agriculture, Studentų 15, 53361 Kaunas-Akademija, Lithuania,

E-mail: algirdas.janulevicius@lzuu.lt

**Lithuanian University of Agriculture, Studentų 15, 53361 Kaunas-Akademija, Lithuania,

E-mail: kazimieras.giedra@lzuu.lt

1. Introduction

Efficiency of work is one of the main tractor rates, i.e. the use of power to carry out useful work. A tractor works economically when no less than 80% of its engine power is used. Seeking to work with greatest economical effectiveness it is necessary to use as great as possible tractor's traction force. Increasing this force increases slippage of tractor wheels. The slippage can be reduced by using wider and duplicated wheels, tires with better protector or by decreasing air pressure in the tires and by pressing driving wheels to the earth with greater force [1 - 3].

To exploit effectively tractors in field conditions (that its slippage would be optimal) it is necessary often to change ballast weights. There is a few clear information about selection of ballast weights. In exploitation of tractors many farmers ballasting carry out occasionally. The values of ballasting masses they select not using any methodology, and without any reasoning. The same ballasting masses they use in light and heavy transport works. In this occasion frequently increases fuel consumption for driving of unnecessary ballasting masses or for great slippage of driving wheels. Increased energy requirement for pulling after tractors ballasting must be compensated and reduced by less slippery of driving wheels. Besides, ballasting of tractor must secure easy control and safe work.

To solve these problems it is necessarily to know wheel grip force and slippage dependencies in various working conditions and its interaction with exploitation properties of the tractor. Physical and mechanical properties of the soil are very different and not steady, therefore grip forces of wheel and soil and the values of slippage often must be measured by experimental way.

Purpose of the work – to estimate interconnection of traction and gravity forces and slippage of the tractor. To make methodology of the tractor ballasting and selection of the ballast masses.

2. Interaction analysis of tractor's dynamic parameters

Driving wheel load of working tractor will be optimal when driving force will be approximately equal to the force of grip ($F_v \leq F_\varphi$), and slippage will not exceed allowable border. Prescribed requirements on tractor steady working regime on horizontal surface can be expressed by the equation

$$P_e \eta_{tr} / v \leq \lambda m_t \varphi g \quad (1)$$

where P_e is effective power of the engine; η_{tr} is coefficient of transmission efficiency; v is ground speed; λ is load

coefficient of driving wheels (when all driving wheels $\lambda=1$); m_t is mass of the tractor; φ is grip coefficient.

In this instance the value of grip coefficient φ must match to the value of weight utilization coefficient φ_g and it must correspond allowable maximal meaning of grip coefficient φ_{leist} in agrotechnical requirements. In operating time physical and mechanical properties of the soil are not the same and not constant and load of driving wheels is not optimal. Therefore the force of the vertical load of driving wheels for grip used only partially. In this instance it is purposeful to connect slippage of the tractor driving wheels δ and another dynamic parameters with coefficient φ_g of weight utilization for the grip. Coefficient φ_g can be denominated by the ratio of greatest tangential traction force F_v and vertical load G_v ($\varphi_g = F_{v \max} / G_v$ or $\varphi_g = F_\varphi / G_v$), calculating tangential force F_v from torque of the engine or F_φ – from the force of wheel grip with the soil [2, 4, 5].

Features of driving wheel are defined by coefficients of grip φ_g , rolling resistance f and slippage δ . Rolling resistance coefficient f evaluate deformation of wheels and soil. Coefficient of wheel efficiency η_v is essential indicator [6].

$$\eta_v = \left(1 - \frac{f}{\varphi_g \lambda_g} \right) (1 - \delta) \quad (2)$$

where λ_g is load coefficient of driving wheels (for all driving wheels $\lambda_g = 1$).

Tractors driving force on horizontal place and constant speed regime is the sum of rolling resistance tractor and traction forces ($F_v = F_f + F_t$). Tractors traction force on horizontal place and constant speed regime is the sum of rolling resistance agricultural machine wheels and technological process resistance forces ($F_t = F_{fm} + F_{tp}$).

In Fig. 1 the dependence of driving wheel traction characteristics on the variation of vertical load [2, 4, 7] is presented. By increasing vertical load of the wheel G , the coefficient of efficiency varies according curve η_v (Fig. 1). Optimal vertical load of driving wheel G_0 is at the greatest coefficient of efficiency. Driving force F_v and force F_f of rolling resistance primarily increases proportionally by increasing vertical load G but when G exceeds G_0 ($G > G_0$), growth of force F_v slows down. The greatest traction force is accessible at given limitary wheel load G_R [4, 6, 7]. In the work it is purposeful to load driving wheels in the zone while the proportionality between vertical loads and driving force is preserved. Slow down of the growth intensity of wheel driving force depends on load is explained that

the force of friction, pressure and shear acting on contact area of the wheel and soil increases not proportionally to the load or pressure [2, 4, 8].

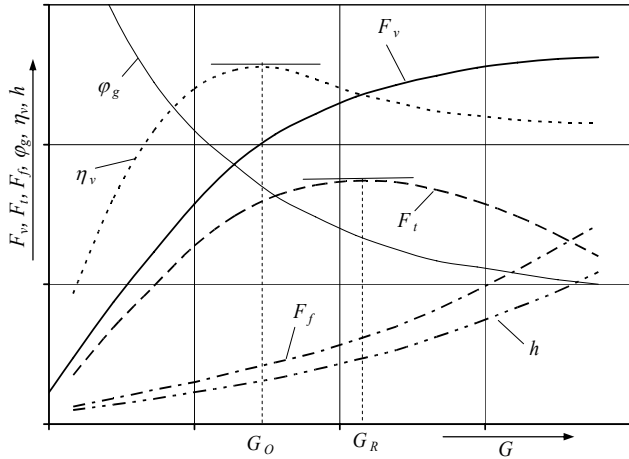

Fig. 1 Dependence of coefficient of efficiency η_v , driving force F_v , traction F_t and rolling resistance F_f forces and depth of rut h on the driving wheel load G

Dependencies of slippage of different mass tractors on traction force in the same soil are different and depend on vertical load G of driving wheels [3, 4, 7]. These loads just determine grip of the driving wheels with the soil and slippage. Therefore to compare different tractors we must use comparative indicators. Such an indicator is weight for wheel grip utilization coefficient ϕ_g . The dependencies ($\delta = f(\phi_g)$) of the slippage δ on the weight utilization coefficient ϕ_g in the various working conditions (Fig. 2) were obtained. The slippage graphic is one of the most important graphics of the traction characteristics because the other tractor parameters (traction power, economics) depend on slippage [1, 9].

Great (>15 %) slippage deteriorates the structure of soil and increases fuel consumption [4, 10 - 13]. The economy of agricultural aggregates characterizes specific fuel consumption b_e and fuel consumption per hour B_d [4, 7]. The fuel consumption l/h for wheel slippage $B_{d\delta}$ and for carrying ballast weights B_{ds} is calculated so [3, 7]

$$B_{d\delta} = P_e \delta \eta_{tr} b_e \quad (3)$$

$$B_{ds} = m_s g f v b_e \quad (4)$$

here P_e is engine power; η_{tr} is coefficient of transmission efficiency; m_s is mass of the ballast.

The excessive ballast mass is useless particularly when working at high speed or on swampy soils. Carrying one ton of the ballast mass on soil prepared for sowing with the speed of 8 km/h the tractor uses about 0.8 l/h fuel. So carrying one ton of the ballast mass and increasing the driving speed from 8 km/h to 40 km/h on the subsurface road the fuel consumption increases by 0.6 l/h [3, 7]. However the increased fuel consumption for carrying ballast mass can be compensated by the lower fuel consumption because of the diminished wheel slippage. Therefore for efficient tractor performance under various field conditions it should be properly ballasted.

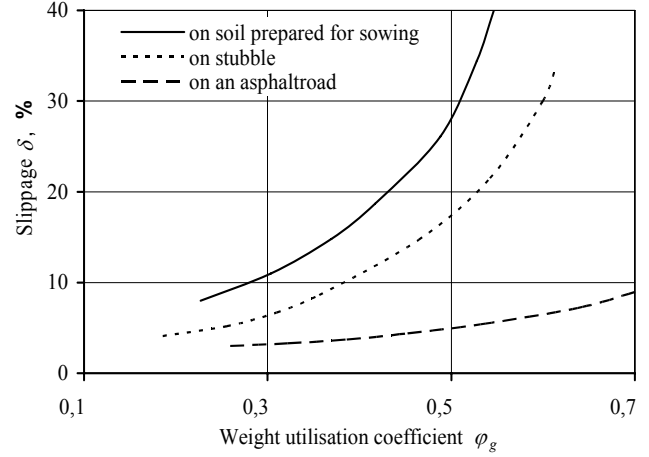

Fig. 2 Dependence of wheel slippage on weight utilization coefficient of tractors [4, 6, 8]

3. Methodology of tractor ballasting

Wheel slippage there is greater than kinematic speed discrepancy between driving wheels when tractor 4x4 with tight front axle gear is working on the soft soil. Therefore all driving wheels give positive driving force F_V [4, 6]. Scheme of forces and torques shown in Fig. 3. If wheels of the tractor has the same diameter and wheel load is approximately the same, therefore torques of front and rear axles M_P and M_V , and its driving forces will be approximately equal: $F_{VP} \approx F_{VV}$, and $\delta_P \approx \delta_V$.

When wheels of the tractor have different diameters, proportion of gear ratios to rear and front axles i_{trV} / i_{trP} is directly proportional to the ratio of wheel radius r_V / r_P and inversely proportional to angular velocity of the wheels ω_V / ω_P

$$\frac{i_{trV}}{i_{trP}} = \frac{r_V}{r_P} = \frac{\omega_P}{\omega_V}$$

Driving forces of the front and rear wheels F_{VP} and F_{VV} will be different and will depend from vertical forces of reactions R_P and R_V on front and rear wheels. Tractors driving forces on horizontal place and constant speed regime when the tractor works with trailing machines is obtained

$$F_{VP} = \phi R_P = \phi \frac{G_T l + G_S (L + l_1) - M_f - F_t h_k}{L} \quad (5)$$

$$F_{VV} = \phi R_V = \phi \frac{G_T (L - l) - G_S l_1 + M_f + F_t h_k}{L} \quad (6)$$

here G_T and G_S are forces of weight accordingly: of the tractor and ballast weights; M_f is torque of rolling resistance ($M_f = M_{fp} + M_{fv} = F_{fp} r_p + F_{fv} r_v$); M_{fp} , M_{fv} , F_{fp} , F_{fv} are torques and forces of rolling resistance accordingly: of the tractor front and rear wheels; l , l_1 , h_k , and L is distances, (Fig. 3)

$$F_{fp} + F_{fv} = F_f = f_p R_p + f_v R_v$$

Rolling resistance coefficient f_p , f_v of front and rear wheels evaluate deformations of accordingly wheels

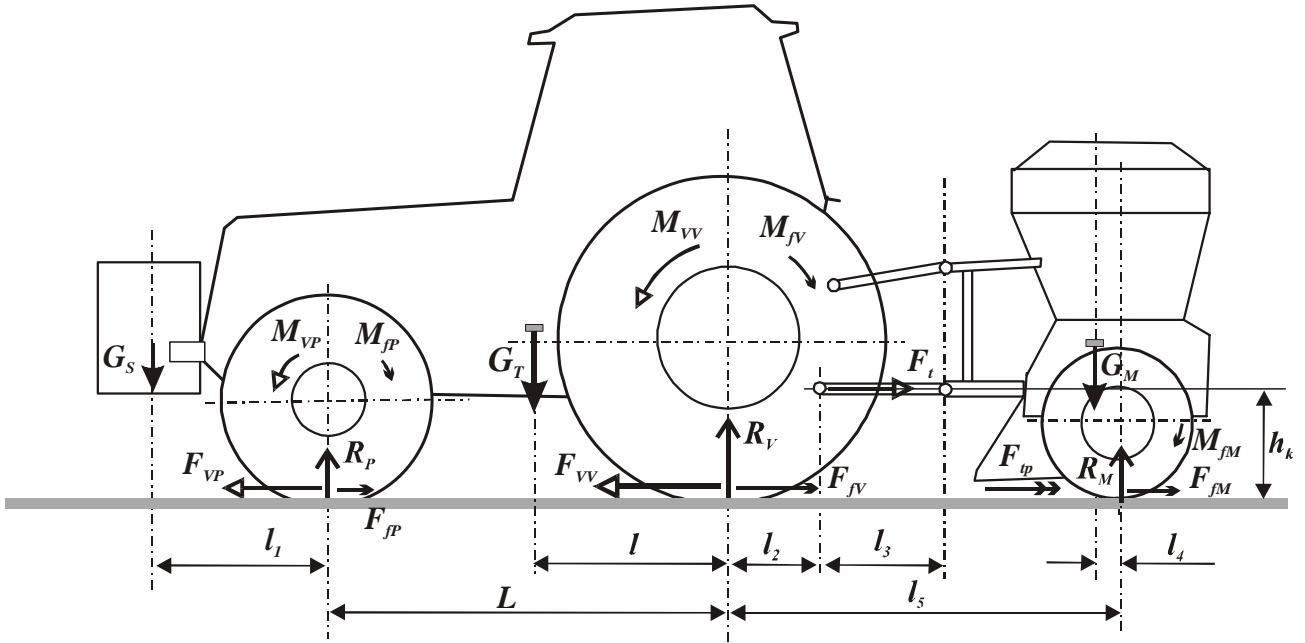

Fig. 3 Scheme of tractor ballasting: G_T ; G_M ; G_S - forces of weight accordingly: of the tractor, of attached machine, of ballast weight; R_P , R_V and R_M - reaction forces of front axle, rear axle and agricultural machine; F_{VP} and F_{VV} - driving forces of front and rear wheels of the tractor; F_{FP} , F_{FV} and F_{FM} - forces of rolling resistance of front, rear of tractor and machine wheels; F_t - tractor traction force; F_{tp} - resistance force of technological process; M_{VP} and M_{VV} - torques of tractor front and rear wheels; M_{FP} , M_{FV} and M_{FM} - torques of rolling resistance of tractor front and rear and machine wheels

and soil. Tractor traction force F_t composes from rolling resistance agricultural machine wheels and resistance of technological process.

Many firms produce 4x4 tractors so that on front wheels would be 40 - 45% of all the tractor mass [14].

Table

Loads on front and rear axles of tractors

Tractors power 85- 89 kW	Front axle		Rear axle	
	kg	%	kg	%
Valtra M-120	2320	44	2970	56
New Holland TS 115A	2010	40	3540	60
John Deere 6520 SE	1930	40	2900	60
Fendt Farmer 412 Vario	2175	42	3065	58
Case-IH CVX 1135	2610	41	3780	59

Guskov, V. V. *et al.* [4], Wong J. [15], Skotnikov, V. A. *et al.* [6] recommends to calculate all mass m of the tractor as follows

$$m_t = \frac{(1,35-145) F_v}{(\lambda \phi - f) g} \quad (7)$$

Slippage of the tractor not enters into this equation. Here it can be set from the equation of weight utilization coefficient of the tractor for load of driving wheels

$$\phi_g = F_v / G_v = F_v / m_t g \quad (8)$$

Evaluating engine power and driving speed the tractor mass can be calculated by the equation

$$m_t = \frac{3600 P_e \chi_p \eta_{tr}}{(\lambda \phi - f) v g} \quad (9)$$

here P_e is engine power in use kW; χ_p is coefficient of engine over loading; η_{tr} is efficiency coefficient of transmission; v is driving speed km/h.

Accepting $\chi_p = 1.15$; $\eta_{tr} = 0.92$; $\lambda = 1$; $\phi = 0.65$ and $f = 0.05$ (on stubble), get

$$m_t = \frac{640 P_e}{v} \quad (10)$$

Available equation is analogous to equation [16] proposed by Silsoe research institute (USA) for the selection of the tractor weight

$$m_t = \frac{650 P_{edv}}{v} \quad (11)$$

here P_{edv} is power of the engine measured through power take off shaft kW.

From Eqs. (2), (3) and (4) it can be seen that at increasing working speed of the tractor its mass must be decreased.

In many of update 4x4 tractors front wheels are loaded 40 - 45% of all the tractor mass. When the tractor works concerning traction force changes the distribution of vertical load on the front and rear axles, and it is difficult to set. USA scientist Frank Zoz [16] calculates the weight transferred from front to rear wheels due to traction force according the simplified equation

$$\Delta G = \xi F_t \quad (12)$$

here ξ is coefficient of the evaluation of weight transferred from front to rear axle.

F. Zoz set [16] that for mounted agricultural ma-

chines with automatic depth and position regulation $\xi = 0.65$; with semimounted machines $\xi = 0.45$ and for trailing machines $\xi = 0.2$. From Eq. (12) available dependencies of weight transferred from front to rear wheels on traction force are presented in Fig. 4.

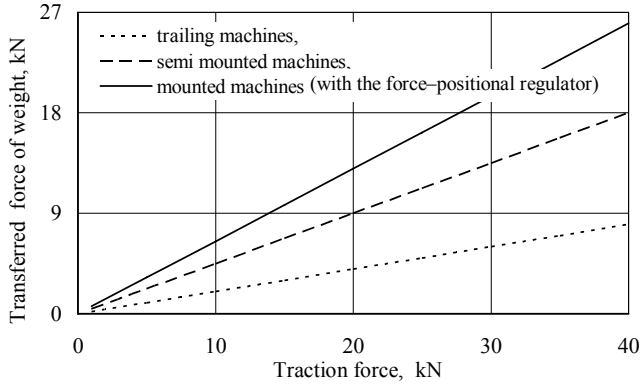

Fig. 4 Dependence of weight force transferred from front to rear wheels on traction force

As it is seen from graph (Fig. 4) most of the weight force is transferred on rear wheels by mounted agricultural machines when alive force – positional regulator (upper line). So, for tractor working with force – position regulator (such aggregates now mostly in use) ballast weight must be fitted up on front of the tractor and mostly protruded to the front to counterbalance transferred weight from front to the rear axle of the tractor and counterbalance turnover torque of heavy hanged machines. According to road state book load of front wheels of the tractor must be no less than 20% of the common tractor weight, and the weight of lifted machine can not exceed 30% of total weight of the tractor. To secure tractors safety driving with hanged machines, minimal value of ballast mass it is possible to calculate from torques of weight forces acting around tread fulcrum of the rear wheel (Fig. 2)

$$G_s \geq \frac{G_M (l_2 + l_3) - 0.2 G_T L}{(l_1 + L)} \quad (13)$$

$$m_s \geq \frac{m_m (l_2 + l_3) - 0.2 m_t L}{(l_1 + L)} = m_{s \min} \quad (14)$$

here m_s , m_m and m_t are masses of ballast weights accordingly: total, attached machine and tractor; l_1 , l_2 , l_3 and L are distances, (Fig. 3).

The value of ballast mass $m_{s \min}$ calculated according Eq. (11) does not ensure greatest efficiency of the tractor work and optimal slippage. The value of optimal ballast mass can be set according the dependence of slippage on coefficient of tractor mass utilization for grip of driving wheels $\delta = f(\phi_g)$. The value of tractor ballast mass for accepted slippage is calculated according the equation:

$$m_{s \text{ opt}} = \frac{k_\phi F_v}{(\lambda \phi_g - f) g} - m_t \quad (15)$$

here k_ϕ is coefficient appreciative type of tractor and work conditions. For wheeled tractors $k_\phi = 1.3 \div 1.45$ [4, 6].

To get optimal value of ballast mass the value of weight utilization coefficient of the tractor ϕ_g and the value of slippage coefficient must be such that coefficient of efficiency η_v would be

$$\eta_v = \left(1 - \frac{f}{\phi_g \lambda g}\right) (1 - \delta) \cong \eta_{v \max} \quad (16)$$

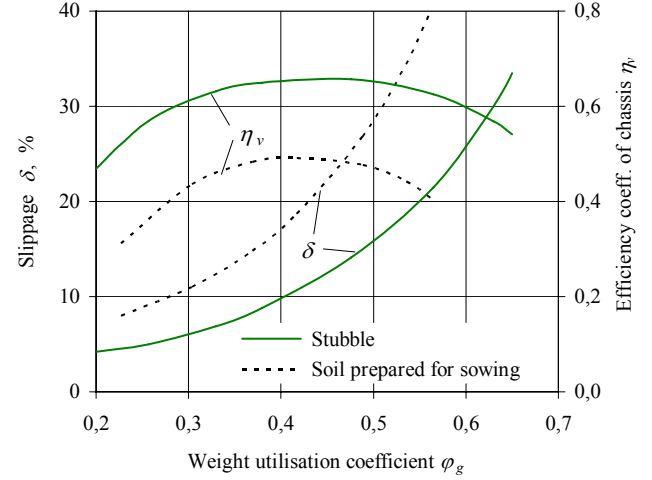

Fig. 5 Dependence of wheel slippage and efficiency coefficient of chassis on weight utilization coefficient of tractors [2, 4, 6]

Weight distribution on the wheels constantly changes when the tractor is working with traction force [16 - 18]. Force of weight transferred from front to rear wheels is interconnected with coefficient of weight utilization for driving wheel load ϕ_g . Under condition $F_v = F_f + F_t$ and from Eqs. 6 and 10 the equation for the calculation of weight force transferred from front to rear wheels which is right when the tractor works on horizontal field at constant speed is obtained:

$$\Delta G = m_t g \xi (\phi_g - f) \quad (17)$$

Dependencies of transferred weight from front to rear wheels on coefficient of weight utilization ϕ_g , for driving wheel load obtained from Eq. (17) presented in Figs. 6, 7 and 8.

4. Results and discussion

For setting interaction of tractor mass m_t and the slippage δ of driving wheels on stubble the nomogram is made (Fig. 6) from three interdependent parts. All parts of the nomogram are connected by common abscise axis, on which the coefficient of utilization of tractor weight for grip of driving wheels ϕ_g is put.

In the bottom part dependencies of wheel slippage on weight utilization coefficient $\delta = f(\phi_g)$ for driving wheel grip adequate for stubble are put. This dependence had been obtained using experimental data [4, 7, 19 - 21]. So, using experimental data, dependencies $m_t = f(\phi_g)$ were located in the middle part of the nomogram. Changing the value of driving wheel grip utilization coefficient ϕ_g , the mass of the tractor m_t was calculated at the

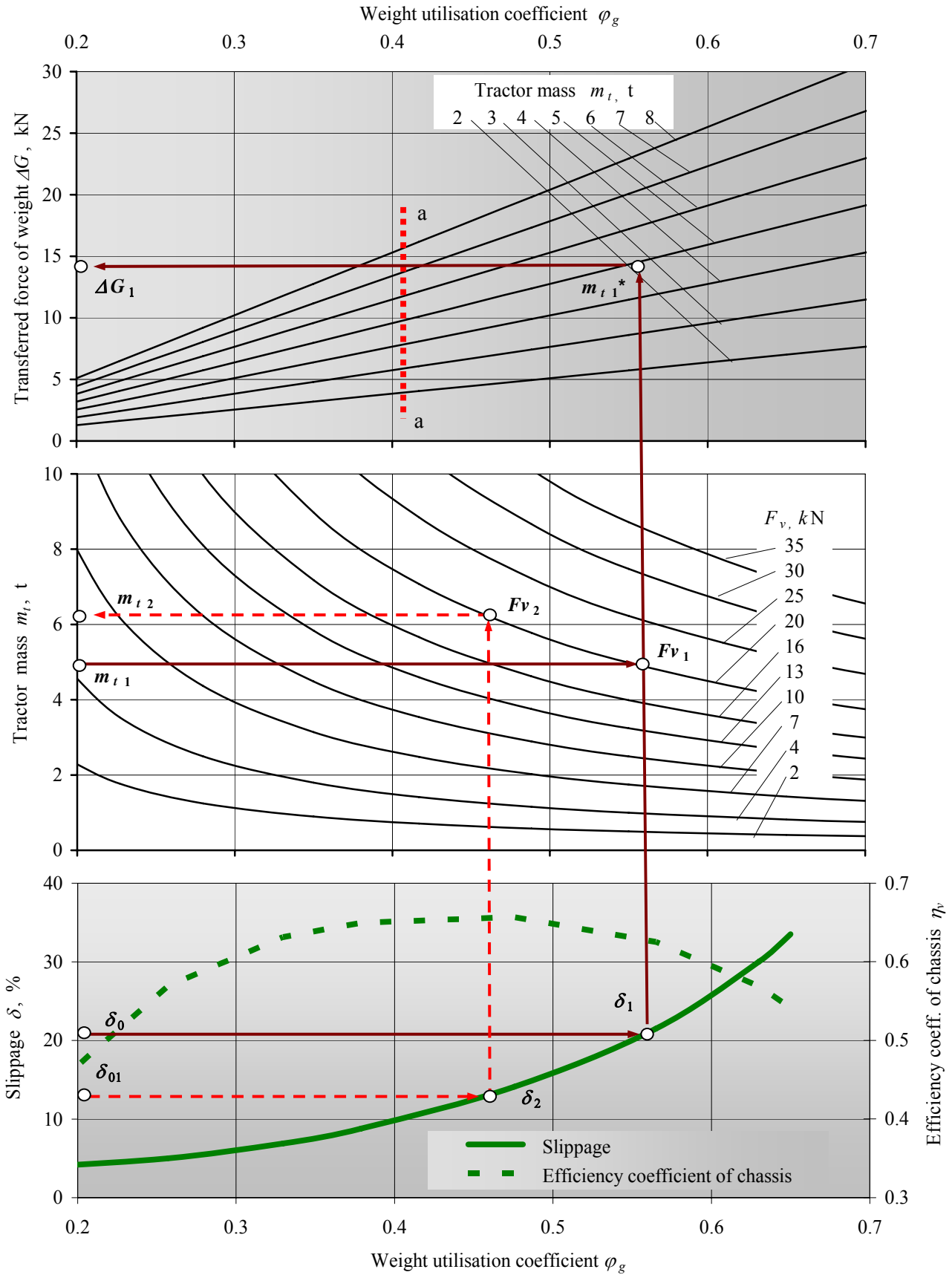

Fig. 6 Nomogram for setting transferred force of weight on the tractor rear wheels and ballast mass and its mounting place on the tractor working with mounted machines on the stubble

same driving force F_v and plotted curves $m = f(\varphi_g)$ correspondent to $F_v = 2; 4; 7; 10; 13; 16; 20; 25; 30$ and 35 kN. Eq. (15) for these calculations was used. Dependence $\Delta G = f(\varphi_g)$ is placed in the top part (dependencies of the

tractor weight force transferred to the rear wheels ΔG on the weight of driving wheel grip utilization coefficient φ_g . Changing the weight of driving wheel grip utilization coef-

efficient φ_g , the tractor weight force transferred to the rear wheels ΔG was calculated at the same mass of tractor m_t and are plotted curves $\Delta G = f(\varphi_g)$ correspond to $m_t = 2; 3; 4; 5; 6; 7$ and 8 tons. Eq. (17) for these calculations was used. Dependencies of transferred weight from front to rear wheels on weight utilization coefficient when tractor works with mounted on machines using force – position depth regulator is presented in Fig. 5. Analogical dependencies are presented in additional figures (Fig. 7 and 8) when the tractor works with semimounted and trailed machines.

By using the nomogram it is possible to set optimal ballast weights of the tractor and the mounting place on the tractor working on the stubble. Working under these conditions at first we must set middle slippage of tractor. Instantaneous wheel slippage is displayed on the instrument cluster of the tractor. After: on the bottom part of the ordinate axis of the nomogram we place wheel slippage δ_0 and mass of the tractor m_{t1} – on the middle part of ordinate axis. From the placed point δ_0 horizontal line draws to the right till the slippage curve (point δ_1). Draw a vertical line from the point δ_1 and from the point m_{t1} placed in the middle part of ordinate axis a horizontal line to the right to the intersection of these lines (point F_{v1}). Point F_{v1} shows traction force F_v . If the point F_{v1} is located between the curves, we must draw a proportional intermediary curve. If current slippage is too great, in such case put the desirable value of slippage δ_{01} on the bottom part of ordinate axis. Draw a horizontal line from that point δ_{01} to the right till slippage curve (point δ_2). Draw a vertical line from the point δ_2 to curve F_v (point F_{v2}). Because F_{v1} and F_{v2} are on the same curve so the values of traction force are equal ($F_{v1} = F_{v2}$). Draw a horizontal line from the point F_{v2} to ordinate axis of the middle part. Here we get the required mass of the tractor m_{t2} to maintain the required wheel slippage δ_2 . To decrease the wheel slippage from δ_1 to δ_2 additional ballast: $\Delta m = m_{t2} - m_{t1}$ is necessary.

Knowing the tractor mass m_t and slippage transferred force of weight ΔG on the rear wheels can be obtained. Draw a vertical line from the point δ_1 up in the top part till the tractor mass curve (point m_{t1}^*). If the values of tractor mass are located between the curves, we must draw a proportional intermediary curve. Draw a horizontal line from the point m_{t1}^* to ordinate axis of the top part (point ΔG_1). Here we get the transferred force of weight of the tractor working with mounted machines. If it is very big, the ballast weights must be fitted in the front of the tractor dismounting it from the rear wheels. In this case, best of all it is to mount the ballast weight on the front three point hitch, as far as possible carried to the front. Transferred force of the weight is very great working with the three point hitch and electronic draft control (Figs. 7 and 8).

Line $a-a$ on the upper part of nomogram shows when the load of front wheel becomes less than 20% of common tractor weight of unballasted tractor (static wheel load is 40x60%). This border is over passed when point m_{t1}^* is in the right side of the line $a-a$. In this case tractor ballasting is needed for the work safety. Ballast weights must be mounted as far as possible to the front of the tractor.

When the tractor works with trailing and semi mounted machines transferred force of the mass from front to the rear wheels can be set with the additional graphs (Figs. 7 and 8).

From Figs. 6, 7 and 8 it is seen that front wheel load becomes less than 20% of all the mass of the tractor working on the stubble with mounted machine when weight utilization coefficient is more than 0.41; with semi-mounted machines – more than 0.55; working with trailing machines load on the front wheels does not decline to such degree.

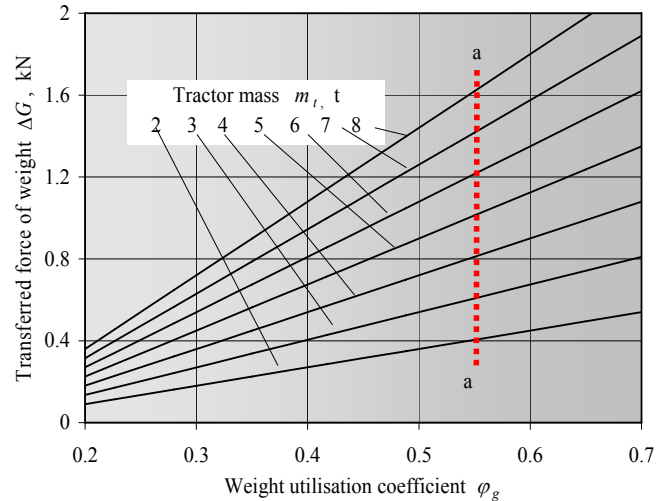

Fig. 7 Dependence of weight transferred from front to rear wheels on weight utilization coefficient when the tractor works with semimounted machines

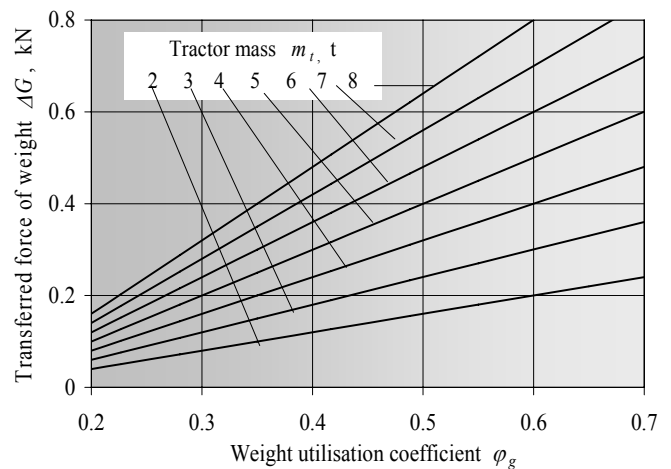

Fig. 8 Dependence of weight transferred from front to rear wheels on weight utilization coefficient when the tractor works with trailing machines

Made up nomogram is suitable to set another tractor exploitation parameters, for example, making aggregate when allowable slippage and mass of the tractor is known it is possible to set maximal traction force. By increasing working speed it is possible to decrease traction force and to make properly aggregate and get economical work of the tractor.

The proposed graphical – analytical method to set the value of ballast mass and place of it fitting can be used for making algorithm for microprocessor and for improving equipment of tractor work control.

Novelty of method for tractor ballasting mass and driving wheel establishment is that various parameters influencing slippage of the wheels connected with weight utilization coefficient for wheel grip. This simplifies and

slippage of driving wheels. This methodic enable new shape and is more cleans and more precise, compare with previous methodic [3, 7]. In previous methodic [3, 7] some parameters were connected with weight utilization coefficient of the tractor, and another connected with traction force.

5. Conclusions

1. Tractor weight utilization coefficient for driving wheel grip as indicator of slippage and tractor ballasting can be used.

2. Derived equations of transferred force of weight ΔG on the rear wheels evaluate its dependence on mass of the tractor and coefficients of weight utilization, evaluate transferred force of weight and rolling resistance of the aggregate.

3. Front wheel load decreases till 20% of all tractor weight when the tractor works an stubble, coefficient of weight utilization is: when working with mounted implements more than 0,4; semimounted machines – more than 0,55 and trailed machines – load of front wheels does not decreases till that level.

4. Required optimal ballast mass for the tractor and its location place can be set by using slippage rate (displaying in the control display) and by created nomogram.

5. To created tractor ballasting methodic adding additional data corresponds all conditions of tractor work it can be used when making various tractor aggregates for field work.

References

1. **Jun, H., Kishimoto, T., Way, T.R., Tauiguihi, T.** Three-directional contact stress distributions for a pneumatic tractor tire in soft soil. -Transactions of the ASAE, 1998, v.41, No 5, p.1237-1242.
2. **Guskov, A.V.** Optimization traction-grip properties of tractor tyres. -Tractors and Agricultural Machines, 2007, No 7, p.19-21 (in Russian).
3. **Giedra, K., Janulevičius, A.** The interaction of tractor traction force, mass and wheel slippage. -Agricultural Engineering. -Raudondvaris, 2004, 36(4), p.108-123 (in Lithuanian).
4. **Guskov, V.V., Velev, N.N.; Atomanov, J.E.** and etc. Tractors; Theory. -Moscow: Mashinostrojenije, 1988. -376p. (in Russian).
5. **Upadhyaya, S., Sime, M., Radhuashi, N., Adler, B.** Semiempirical traction prediction equations based an relevant soil parameters. -J. Terramechanics, 1997, 34(3), p.141-154.
6. **Kutkov, G.M.** Tractors and Automobiles. Theory and Technological Properties. -Moscow: Kolos, 2004. -384p. (in Russian).
7. **Giedra, K., Janulevičius, A.** Tractor ballasting in field transport work. -Transport.-Vilnius: Technika, 2005, v.XX, No4, 152-158p.
8. **Gonsharenko, C.V., Godzaev, Z.A., Stankievich, E.B.** and etc. Identification of tyres using exploitation indicators. -Tractors and Agricultural Machines, 2007, No7, p.16-19. (in Russian).
9. **Janulevičius, A., Giedra, K.** Investigation of interface between the wheel slippage and the ratio of trailer and tractor mass. -Engineering. -Kaunas: Akademija, 2007, v.8, No1, p.76-80 (in Lithuanian).
10. **Air pressure, weight and fuel consumption: Diesel savings of 10%. Tractor Profit and Farm Machinery, 2005, No. 9, p.20-23.**
11. **Plaksin, A. M., Zyrianov, A.P.** Energetical parameters for use aggregates and different ion of tractor mass. -Tractors and Agricultural Machines, 2008, No2, p.22-24 (in Russian).
12. **Samorodov, V.B., Koval, A.A.** Spatial - topological interaction of productivity, working speeds, slippage, weight and engine power of wheeled tractors. -Tractors and Agricultural Machines, 2008, No4, p.19-22 (in Russian).
13. **Samsonov, V.A.** Evaluation of efficiency and compare tractors on its projecting and modernizing. -Tractors and Agricultural Machines, 2006, No3, p.19-21 (in Russian).
14. **Tractor catalogue 2006, profi International.**
15. **Vong, D.** Theory of above – Ground Vehcele. -Moscow: Mashinostrojenije, 1988.-284p. (in Russian).
16. **Carrol, E.** Gearing Engine and Tractor Power: ASAE Text Book Nr.7. -Michigan, 1992.-539p.
17. **Ivanov, R., Rusev, R., Ilchev, P.** Laboratory investigation of tyre sliding grip coefficient. -Transport, -Vilnius: Technika, 2006, v.XXI, No3, p.172-181.
18. **Prentkovskis, O., Bogdevičius, M.** Dynamics of a motor vehicle taking into consideration the interaction between wheels and road pavement surface.-Transport, 2002, 16(6), p.244-253.
19. **Janulevičius, A., Juostas, A.** The interaction between pulling power and fuel consumption of the tractor during draft mode applications.-In Proc. of the 12th Int. Conf. “Mechanika”, 2007, p.96-101.
20. **Juostas, A., Janulevičius, A.** Investigation of tractor engine power and economical working conditions utilization during transport operation. -Transport.-Vilnius: Technika, 2008, 23(1), p.37-43.
21. **Nagaoka, A.K., Lancas, K., Castro Neto, P., Benez, S.H.** Evaluation of single wheel testing device with mechanical transmission. -ASABE technical library. -USA, California, 2001. -13p.

A. Janulevičius, K. Giedra

TRAKTORIAUS BALASTAVIMAS LAUKO DARBAMS

R e z i u m ė

Straipsnyje apžvelgiama, dėl kurių priežasčių reikia balastuoti traktorius. Pateikta traktoriaus traukos ir svorio jėgų bei ratų buksavimo tarpusavio sąveikos analizė. Analizuojamos traktoriaus buksavimo priklausomybės nuo svorio jėgos panaudojimo varančiųjų ratų sukibimui koeficiento. Ištirta sąveika tarp traktoriaus balastavimo ir svorio jėgos panaudojimo varančiųjų ratų sukibimui koeficiento.

Pateikiama svorio jėgos, perkeliama nuo priekinių ant užpakalinių ratų, priklausomybių nuo traktoriaus masės ir svorio jėgos panaudojimo varančiųjų ratų sukibimui, perkeliama svorio vertės ir riedėjimo pasipriešinimo koeficientų lygtis. Sudaryta traktoriaus balastavimo bei balastinių masių dydžio nustatymo metodika. Pateikta no-

mograma traktoriaus balastinės masės optimaliam dydžiui ir jos tvirtinimo vietai nustatyti, žinant vidutinį momentinį ratų buksavimą.

Pateikta nomogramos naudojimo metodika, apžvelgtos jos naudojimo galimybės.

A. Janulevičius, K. Giedra

TRACTOR BALLASTING IN FIELD WORK

S u m m a r y

In the article the necessity of tractor ballasting is over viewed. The analysis of interaction of traction force, forces of weight and slippage of the wheels is presented. A dependency of tractor slippage on coefficient of weight utilization for driving wheel grip is analyzed. An interaction between tractor ballasting and coefficient of weight utilization for driving wheel grip is investigated.

Equations of dependencies of weight force transferred from front to rear wheel on tractor mass and coefficients of: weight utilization for wheel grip value of transferred weight and rolling resistance are presented. Method for tractor ballasting and setting the value of ballast mass is proposing. The nomogram for setting optimal value of ballast mass and its fitting place, when medium instantaneous wheel slippage is known is presented

Methods of nomogram usage and revive of utilization possibilities are presented.

А. Янулявичюс, К. Гедра

БАЛЛАСТИРОВКА ТРАКТОРА В ПОЛЕВЫХ РАБОТАХ

Р е з ю м е

В статье приведен обзор причин необходимой балластировки тракторов. Представлен анализ взаимодействия тяговой силы, сил тяжести и буксования ведущих колес. Анализируются зависимости буксования трактора от коэффициента использования веса трактора при сцеплении ведущих колес с почвой. Исследовано взаимодействие балластировки трактора и коэффициента использования сцепного веса. Представлены уравнения сил веса, перенесенных с передних колес на задние в зависимости от массы трактора и коэффициентов: использования цепного веса, переносимой силы веса и сопротивления качению.

Составлена методика балластировки трактора и определения величины балластных масс. Предложена номограмма для определения оптимальной величины балластировки трактора и определения места её расположения, при известном значении моментного среднего буксования колес.

Представлена методика пользования диаграммой и приведен обзор возможностей ее применения.

Received August 12, 2008

DOI: 10.5755/j02.mech.15156