

# Multiresolution derives analysis of module mechatronical systems

**A. Nowak, M. Woźniak**

Faculty of Mathematics and Physics, Institute of Mathematic, Silesian Technical University, Str. Kaszubska 23, 44-101 Gliwice, Poland, E-mail: andrzej.nowak@polsl.pl, marcin.wozniak@polsl.pl

## 1. Introduction

The aim of this article is to present mathematical methods and analyze algorithms of module systems like:

- reliability theory based on Barlow's theory,
- transmission calculation,
- dynamical characteristics calculation.

Further researches leads to solving parametrical optimization of active module systems.

In article two cases of module systems are examined. The first is module system without any regulator (passive), the second with power regulator (active) [1-6]. An algorithm is illustrated for module system with regulator type PID (Proportional-Integral-Derivative controller), where the first module is set for electrical transmitter and the other is modelling signal received by receiver [1, 2, 5, 6]. Particular calculations were made with Maple calculation system. In the paper the problem of optimization of dynamical characteristics of the machines vibroisolation systems is analysed. Active models of the vibroisolation systems are considered [4, 6-8]. The main conditions for construction of the dynamical models of the vibroisolation systems to optimization procedure are following:

- considering models of the driving subsystems with only electrical DC motor and with feedback element, particularly by the use of PID control element,
- impulse or harmonic force is assumed, without random processes.

Results of numerical calculations in terms of displacements' courses, the accelerations and vibroisolation forces are presented.

## 2. Reliability and structural function of module systems

In Fig. 1 the series module system and its dual parallel system are shown. There by  $F_{in}(t)$  the probability function for  $i$  block is denoted, however the symbol  $R_{in}(t)$  of the reliability function is expressed. The probability and the reliability functions of the module system are given in the following formulas

$$\left. \begin{aligned} F(t) &= \prod_{i=1}^N [1 - R_i(t)] \\ F_s(t) &= F_1(t) F_2(t) \dots F_n(t), F_i(t) = 1 - R_i(t) \\ R(t) &= 1 - \prod_{i=1}^N [1 - R_i(t)] = \prod R_i(t) \end{aligned} \right\} \quad (1)$$

where  $\prod$  is named as Barlow's symbol.

We define the damage intensity function

$$\lambda(t) = \frac{f(t)}{R(t)} = \frac{f(t)}{1 - F(t)} = \frac{f(s)}{1 - F(s)} \quad (2)$$

The probability function of the module system

$$P_s = p_1 p_{10} (P_{1m} P_{2m} + P_{3m} - P_{1m} P_{2m} P_{3m}) \quad (3)$$

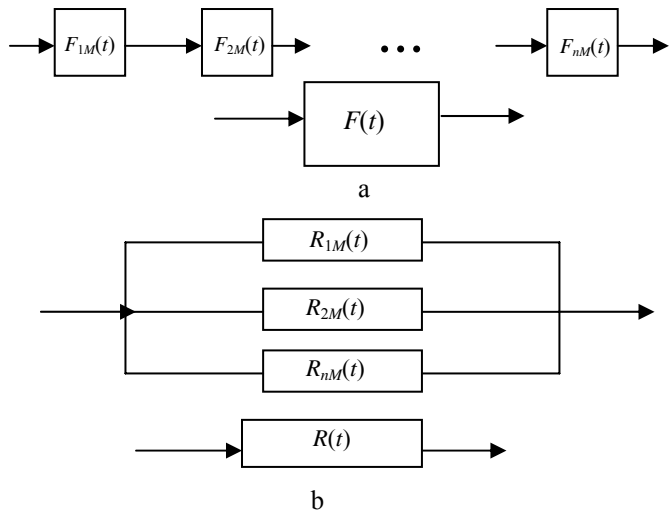

Fig. 1 Series module system (a) and dual parallel system (b)

For module system that is shown in Fig. 2 it is determined the structural function with substituted variables  $\phi_i(x_j)$

$$\phi(x) = x_1 x_{10} [ \phi_1(x_1) \phi_2(x_2) + \phi_3(x_3) - \phi_1(x_1) \phi_2(x_2) ]$$

where

$$\phi_3(x_3) = x_1 x_{10} [ (x_2 x_3 + x_4 - x_2 x_3 x_4) (x_7 + x_8 - x_7 x_8) + x_9 (x_5 + x_6 - x_5 x_6) - x_9 (x_5 + x_6 - x_5 x_6) (x_2 x_3 + x_4 - x_2 x_3 x_4) (x_7 + x_8 - x_7 x_8) ]$$

Probability of the modules of the system (Fig. 3)

$$P_{1m} = P_2 P_3 + p_4 - p_2 p_3 p_4, P_{2m} = p_7 + p_8 - p_7 p_8$$

$$P_{3m} = p_9 (p_5 + p_6 - p_5 p_6)$$

in conclusion for the main system it is obtained

$$P_s = p_1 p_{10} (P_{1m} P_{2m} + P_{3m} - P_{1m} P_{2m} P_{3m}) =$$

$$= P_1 P_{10} \left[ (P_2 P_3 + P_4 - P_2 P_3 P_4) (P_7 + P_8 - P_7 P_8) + \right. \\ \left. + P_9 (P_5 + P_6 - P_5 P_6) - P_9 (P_5 + P_6 - P_5 P_6) \times \right. \\ \left. \times (P_2 P_3 + P_4 - P_2 P_3 P_4) (P_7 + P_8 - P_7 P_8) \right]$$

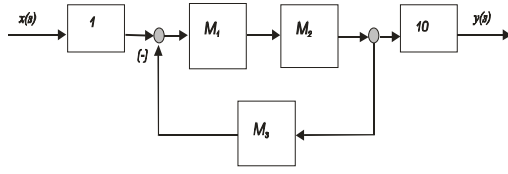

Fig. 2 An example of a nonregulated circuit

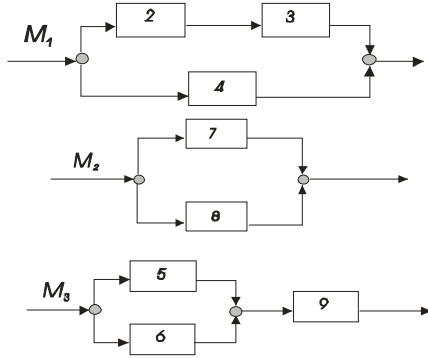

Fig. 3 Modules implied into the main system

Let the probability distribution function be assumed

$$P_i = F_i(t) = 1 - e^{-\lambda t}$$

Probability function is defined

$$F(t) = (1 - e^{-\lambda t})^4 (1 + e^{-\lambda t}) \left[ 2 - 3(1 - e^{-\lambda t})^2 + 3(1 - e^{-\lambda t})^4 - \right. \\ \left. - (1 - e^{-\lambda t})^5 \right] = (1 - e^{-2\lambda t}) (1 - e^{-\lambda t})^3 (1 - e^{-\lambda t} + 5e^{-2\lambda t} - \\ - 2e^{-3\lambda t} - 2e^{-4\lambda t} + e^{-5\lambda t}) = (1 - e^{-2\lambda t}) (1 - 3e^{-\lambda t} + 2e^{-2\lambda t} + \\ + 2e^{-3\lambda t} - 3e^{-4\lambda t} + e^{-5\lambda t}) = 1 - 3e^{-\lambda t} + e^{-2\lambda t} + 5e^{-3\lambda t} - \\ - 5e^{-4\lambda t} - e^{-5\lambda t} + 3e^{-6\lambda t} - e^{-7\lambda t}$$

Reliability function is defined

$$R(t) = 1 - F(t) = 3e^{-\lambda t} - e^{-2\lambda t} - 5e^{-3\lambda t} + 5e^{-4\lambda t} + e^{-5\lambda t} - \\ - 3e^{-6\lambda t} + e^{-7\lambda t}$$

Probability density function is defined

$$f(t) = \lambda e^{-\lambda t} (3 - 2e^{-\lambda t} - 15e^{-2\lambda t} + 20e^{-3\lambda t} + 5e^{-4\lambda t} - \\ - 18e^{-5\lambda t} + 7e^{-6\lambda t})$$

Damage intensity is defined

$$\lambda(t) = \lambda (3 - 2e^{-\lambda t} - 15e^{-2\lambda t} + 20e^{-3\lambda t} + 5e^{-4\lambda t} - 18e^{-5\lambda t} +$$

$$+ 7e^{-6\lambda t}) / (3 - e^{-\lambda t} - 5e^{-2\lambda t} + 5e^{-3\lambda t} + e^{-4\lambda t} - 3e^{-5\lambda t} + e^{-6\lambda t})$$

where is set  $\lambda(0) = 0$ ,  $\lambda(\infty) = \lambda$ .

For the readiness time as set durability can be calculated from the equation

$$T_0 = E[T] = \int_0^{\infty} R(t) dt = \frac{1}{\lambda} \left( 3 - \frac{1}{2} - \frac{5}{3} + \frac{5}{4} + \frac{1}{5} - \frac{1}{2} + \frac{1}{7} \right) = \\ = \frac{45}{35\lambda}$$

In the case of the regular distribution of the elements of the system

$$f_i(t) = c, \quad F_i(t) = ct, \quad c = \frac{1}{T}$$

on the elements numerated as follows  $i = 1, 2, \dots, 10$

$$F_{1M} = ct(1 + ct - c^2 t^2), \quad F_{2M} = ct(2 - ct), \quad F_{3M} = c^2 t^2(2 - ct)$$

- then the original main probability function

$$F(t) = c^4 t^4 \left[ (1 + ct - c^2 t^2) + 1 - c^2 t^2 (2 - ct) (1 + ct - c^2 t^2) \right] \\ (2 - ct) = c^4 t^4 \left\{ 1 + (1 + ct - c^2 t^2) [1 - c^2 t^2 (2 - ct)] \right\} (2 - ct) = \\ = t^4 (4 - 7t^2 + t^3 + 7t^4 - 5t^5 + t^6), \quad t = ct$$

- the density probability function

$$f(t) = ct^3 (16 - 42t^2 + 7t^4 + 56t^5 - 45t^6 + 6t^7)$$

for  $0 \leq t \leq 1$

- the reliability function

$$R(t) = 1 - t^4 (4 - 7t^2 + t^3 + 7t^4 - 5t^5 + t^6)$$

$$T_{0r} = F[T_r] = \int_0^1 \left[ 1 - t^4 (4 - 7t^2 + t^3 + 7t^4 - 5t^5 + t^6) \right] dt = \\ = T \left[ 1 - \frac{4}{5} + 1 - \frac{1}{8} - \frac{7}{9} + \frac{1}{2} - \frac{1}{11} \right] = \frac{3517}{3960} T.$$

### 3. Mathematical model of active module system with PID element

General equation of the active vibroisolation system in term of the two differential matrix equations is considered [9, 10]

$$M\ddot{x} + B\dot{x} + Cx + D(x) = F(t) - Ku(t) \quad (4)$$

$$\dot{u} = Gu + Lu + H\dot{x} \quad (5)$$

where  $\mathbf{K} > \mathbf{0}$  is the diagonal matrix for the control coefficients  $\mathbf{L}$ ,  $\mathbf{H}$  are the positive determine matrix, which elements are of the parameters of the control elements.

Eq. (5) expresses the mathematical model of the control element PID in matrix description. In analysis the diagonal terms of the control matrix are assumed:  $\mathbf{L} = \text{diag} [L_i]$ ,  $\mathbf{H} = \text{diag} [h_i]$ ,  $\mathbf{G} = \text{diag} [g_i]$ . Multiplying the Eq. (1) by inverse matrix  $\mathbf{B}^{-1}$  we obtain the following system of two equations [9, 10]

$$\ddot{x} + b\dot{x} + cx + d(x) = f(t) - ku(t) \quad (6)$$

$$\dot{u} = Gu + Lx + H\dot{x} \quad (7)$$

Assuming  $H = 0$  and  $\dot{u} = 0$  is obtained the model with static control system

$$Gu = Lx \rightarrow u = gx, \quad g = G^{-1}L \quad (8)$$

The Eqs. (6) and (7) can be presented in term of the only one equation with 3-order. By differentiation of the Eq. (7) regard to the time and putting into the Eq. (6) is written

$$\left. \begin{aligned} \ddot{x} + b\dot{x} + cx + d(x) &= f(t) - ku(t), \quad \ddot{u} = G\dot{u} + L\dot{x} + H\ddot{x} \\ \ddot{x} + b_1\dot{x} + c_1x + ex &= f'(t) - kGu(t) \end{aligned} \right\} \quad (9)$$

The characteristic equation of the system has following term

$$\det \left| Er^3 + b_1r^2 + c_1r + e \right| = 0 \quad (10)$$

According to the Routh-Hurwitz theorem the active system would be stabile, when the each roots of the characteristic Eq. (7) haven't positive real part [5-7]. Next is considered the system with harmonic extortion forces  $f(t) = f_0 + f_1 \sin \omega t$  and the similar term for control signals  $u(t) = u_0 + u_1 \cos \omega t$ , where  $f_1 \ll f_0$ ,  $u_1 \ll u_0$ . There is assumed the following dependences for elimination of the forces amplitudes  $f_0$

$$ku_0 = f_0 \rightarrow u_0 = k^{-1} f_0 \quad (11)$$

In such case the amplitudes of the control signals should be compensation of the amplitudes  $f_1$  of the dynamical harmonic signals

$$(kG)u_1 = \omega f_1 \rightarrow u_1 = \omega(kG)^{-1} f_1 \quad (12)$$

On basis of the Eqs. (8) and (9) is formulated the dependence for determination of the control matrices and it's parameters

$$La = Haw \rightarrow L = wH \quad (13)$$

To prove numerical calculations of the Eqs. (9)

the active system is presented in term of the three equations with 1-order

$$z = Tz + D(x) + F(t) \quad (14)$$

where

$$T = \begin{bmatrix} 0 & E & 0 \\ -c & -b & -k \\ L & H & G \end{bmatrix}, \quad d = [0 - d 0]$$

$$z = [x, v, u]^T, \quad F = [0, f, 0]^T.$$

#### 4. Modelling of the regulated module circuit system

Main system without any power regulator can be set as in Fig. 2. Where modules are established as combinations shown in Fig. 3. Then for all module objects is set

$$\left. \begin{aligned} T_1(s) &= \frac{b_1}{s+a_1}, \quad T_2(s) = \frac{b_2}{s+a_2}, \quad T_3(s) = \frac{b_3}{s+a_3} \\ T_4(s) &= \frac{b_4}{s+a_4}, \quad T_7(s) = \frac{b_7}{s+a_7}, \quad T_8(s) = \frac{b_8}{s+a_8} \\ T_5(s) &= \frac{b_r}{s}, \quad T_6(s) = a_r s, \quad T_9(s) = K_r \\ T_{10}(s) &= \frac{b_0 + K_0}{a_{10}s^2 + b_{10}s + c_{10}} \end{aligned} \right\} \quad (15)$$

Then for main module's transmissions

$$\left. \begin{aligned} T_{1M}(s) &= T_2(s)T_3(s) + T_4(s), \quad T_{2M}(s) = T_7(s) + T_8(s) \\ T_{3M}(s) &= T_9(s)[T_5(s) + T_6(s)] \end{aligned} \right\} \quad (16)$$

Regulated system is shown as in Fig. 4.

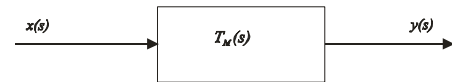

Fig. 4 Simplified figure of the main circuit

For the system from Fig. 1 main transmittance is realized

$$T_M(s) = T_1(s)T_{10}(s) \frac{T_{1M}(s)T_{2M}(s)}{1 + T_{1M}(s)T_{2M}(s)T_{3M}(s)} \quad (17)$$

$$R(s) = K_1 + \frac{a}{s} + bs$$

It is implied equation as follows

$$T_M(s) = 2b_1b_2^2 \frac{c_0 + b_0s}{D_M(s)} = A_0 \frac{D_1(s)}{D(s)} \quad (18)$$

with setting parameters

$$\Delta_r = a_0s^5 + d_1s^4 + d_2s^3 + d_3s^2 + d_4s + d_5 \quad (19)$$

where variables' parameters in equation are defined as

$$\left. \begin{aligned} d_5 &= a_1 a_2 c_0 \\ d_4 &= a_2 c_0 + 2a_1 a_2 c_0 + 2akb_1 b_2 c_0 \\ d_3 &= 2a_2 c_0 + a_2^2 b_0 + a_1 c_0 + 2a_1 a_2 b_0 + \\ &+ a_1 a_0 a_2^2 + 2akb_1 b_2^2 b_0 \\ d_2 &= c_0 + 2a_2 b_0 + a_0 a_2^2 + a_1 b_0 + 2a_1 a_2 a_0 \\ d_1 &= b_0 + 2a_0 a_2 + a_1 a_0 \end{aligned} \right\} \quad (20)$$

Then for the set main function of amplitude characteristic is calculated

$$\begin{aligned} AA_M(\omega) &= \\ &= 2b_1 b_2^2 \sqrt{\frac{c_0^2 + b_0^2 \omega^2}{(d_5 - d_3 \omega^2 - d_1 \omega^4)^2 + \omega^2 (d_4 - d_2 \omega^2 + a_0 \omega^4)^2}} \end{aligned} \quad (21)$$

from Eq. (2) is evaluated

$$a_0 y^v + d_1 y^{iv} d_2 y^{iii} + d_3 y^{ii} + d_4 y + d_5 = 2b_1 b_2^2 (c_0 x + x^l) \quad (22)$$

For active system with power regulator type PID (Fig. 5) main transmittance is set in equation

$$T(s) = \frac{T_M(s)}{1 + T_M(s)R(s)} \quad (23)$$

Particular formula of the transmittance is defined as

$$T_M(s) = \frac{2b_1 b_2^2 (c_0 + b_0 s)}{(s + a_1)(s + a_2)^2 (a_0 s^2 + b_0 s + c_0) + 2a_r k_r b_1 b_2^2 (k_0 + b_0 s)s} \quad (24)$$

with transmittance of the control element PID

$$R(s) = K_s + \frac{a_s}{s} = \frac{K_s s + a_s}{s} \quad (25)$$

by simplifying the main record of the set

$$\left. \begin{aligned} D_{1M}(s) &= c_0 + b_0 s \\ \Delta_M(s) &= (s + a_1)(s + a_2)^2 (a_0 s^2 + b_0 s + c_0) + \\ &+ 2a_r k_r b_1 b_2^2 (k_0 + b_0 s)s \\ A_0 &= 2b_1 b_2^2 \end{aligned} \right\} \quad (26)$$

Then the main transmittance of the regulated system with element PID can be set in term

$$T(s) = \frac{A_0 \frac{D_{1M}(s)}{D_M(s)}}{1 + A_0 \frac{D_{1M}(s)}{D_M(s)} R(s)} \quad (27)$$

what is equal to

$$T(s) = \frac{A_0 D_{1M}(s)s}{sD_M(s) + A_0 D_{1M}(s)(ka + a)} = \frac{D_1(s)}{D(s)} \quad (28)$$

From Eq. (28) is evaluated the 6 order differential equation of the regulated system

$$\begin{aligned} a_0 y^{vi} d_1 y^v + d_2 y^{iv} d_3 y^{iii} + \check{d}_4 y^{ii} + \\ + \check{d}_5 y^i + d_6 y = A_0 b_0 x^{ii} + A_0 c_0 x \end{aligned} \quad (29)$$

where variables' parameters in the equation are defined with extension for local parameters

$$\left. \begin{aligned} d_6 &= A_0 e k_0 \\ \check{d}_5 &= d_5 + A_0 k_0 k_1 + A_0 a_2 b_0 \\ \check{d}_4 &= d_4 + A_0 k_0 k_1 + A_0 a_2 b_0 \end{aligned} \right\} \quad (30)$$

For regulated circuit function of amplitude characteristic and acceleration characteristic is realized

$$A(\omega) = A_0 \omega \sqrt{\frac{c_0 + b_0^2 \omega^2}{D(\omega)}}, \quad P(\omega) = \omega^2 A(\omega) \quad (31)$$

Circuit from Fig. 5 can be simplified according to modules presented in Fig. 1. Main electrical circuit model of the system with power regulator is presented in Fig. 6.

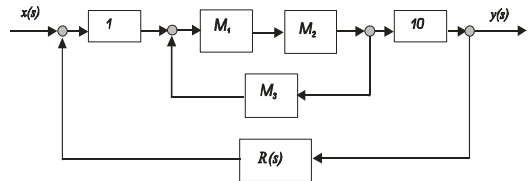

Fig. 5 Example of main circuit with power regulator

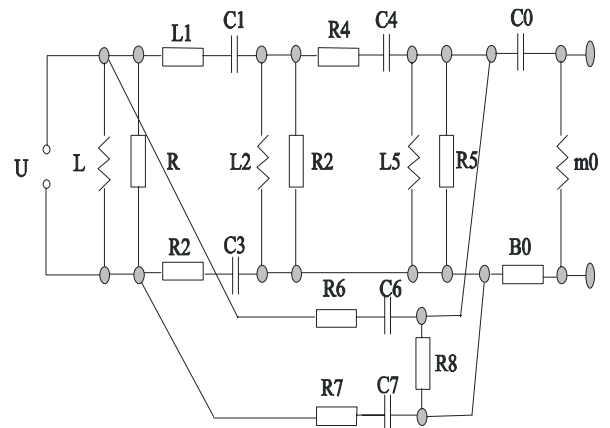

Fig. 6 Example of simplified main circuit with power regulator

## 5. Results of numerical calculations of the regulated active system

The mechatronical model of the system with current steady motor is shown in Fig. 7. This system is correspondent to circuit module system in Fig. 5. There the vibroisolation subsystem exists in term of the mass  $m$ , the

spring  $c$  and the resistance  $b$ . Calculation for this example can be lead for set variables

$$m_0 = 1000 \text{ kg}, c_0 = 500 \text{ kN/m}, b_0 = 100 \text{ kNs/m},$$

$$K_0 \in \langle 0, 500 \rangle, a_r = 1.0, b_r = 1.0, a_1 = 100,$$

$$b_1 = 20, a_2 = a_3 = a_7 = a_8 = 50, b_2 = b_3 = b_7 =$$

$$= b_8 = 10, a_r = 100, b_r = 100, K_s = 100$$

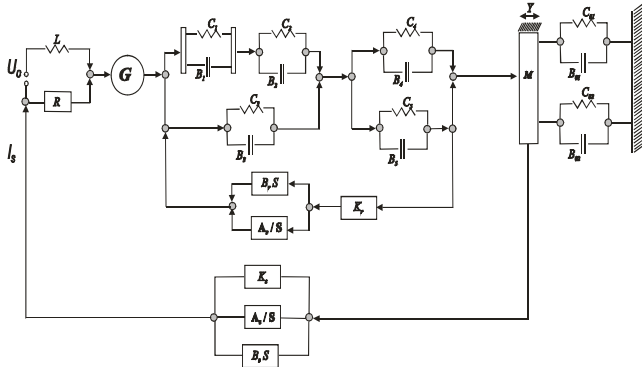

Fig. 7 Mechatronical model of the active regulate system with PID element

From Eq. (18) after implying all variables into equation is achieved derives equation of 6 level for function  $y(x)$  what is equal to other one

$$1000y^{VI} + 200100y^{IV} + 1252500y''' + 371350000y'' +$$

$$+ 65025000y' + 2500000993y = 4000 (500x + x')$$

Frequency characteristics of acceleration is presented in Fig. 8. Courses of the displacement (a) and acceleration (b) in case of the nonregulated system are shown in Fig. 9. Frequency characteristics of the acceleration for regulated system are shown in Fig. 10. Next the courses of the displacement (a), the acceleration (b) and the plane trajectory in case of the regulated system are given in Fig. 11 for frequency  $f = 3 \text{ Hz}$  and  $a_s = 100$ ,  $K_s = 100$ . Next the courses of displacement (a), the acceleration (b) and the plane trajectory for  $a_s = 100$ ,  $f = 4 \text{ Hz}$  are shown in Fig. 12.

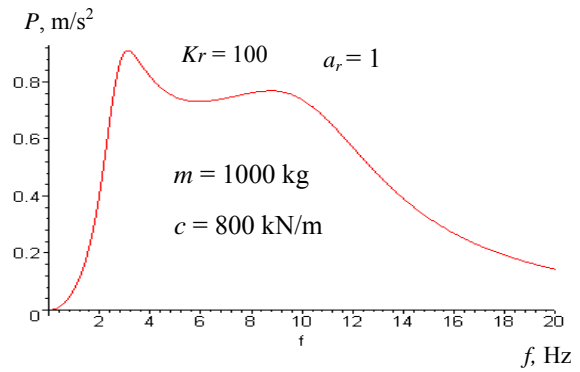

Fig. 8 Frequency characteristics of acceleration

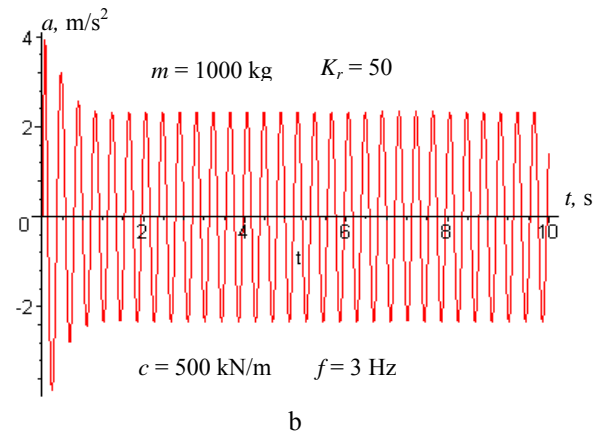
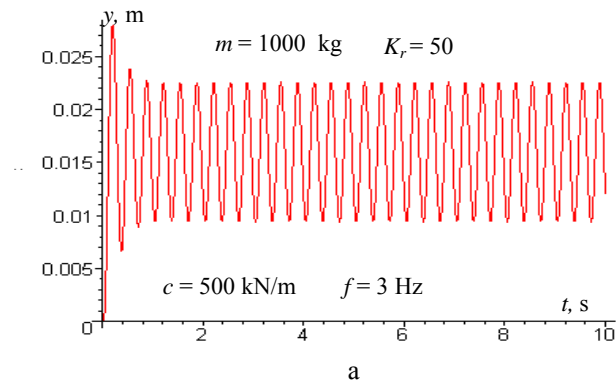

Fig. 9 Courses of the displacement (a), the acceleration (b) in case of nonregulated system

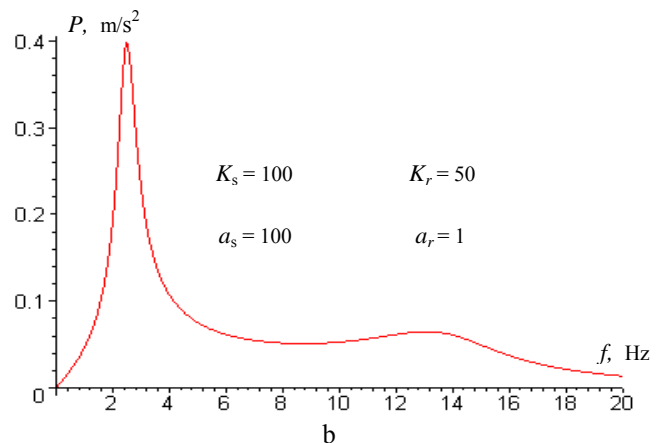
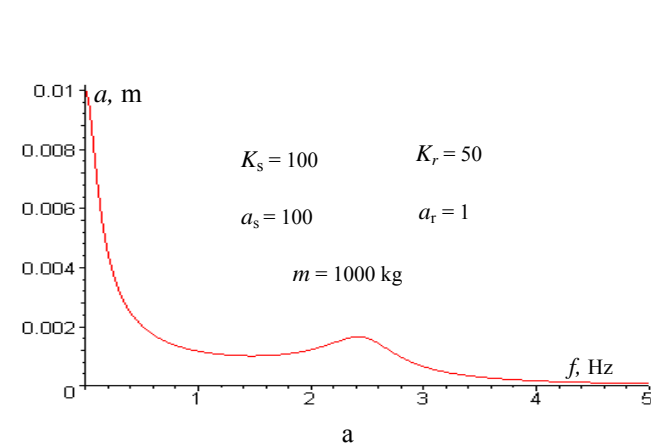

Fig. 10 Frequency characteristics of displacement (a) the acceleration (b) for regulated system

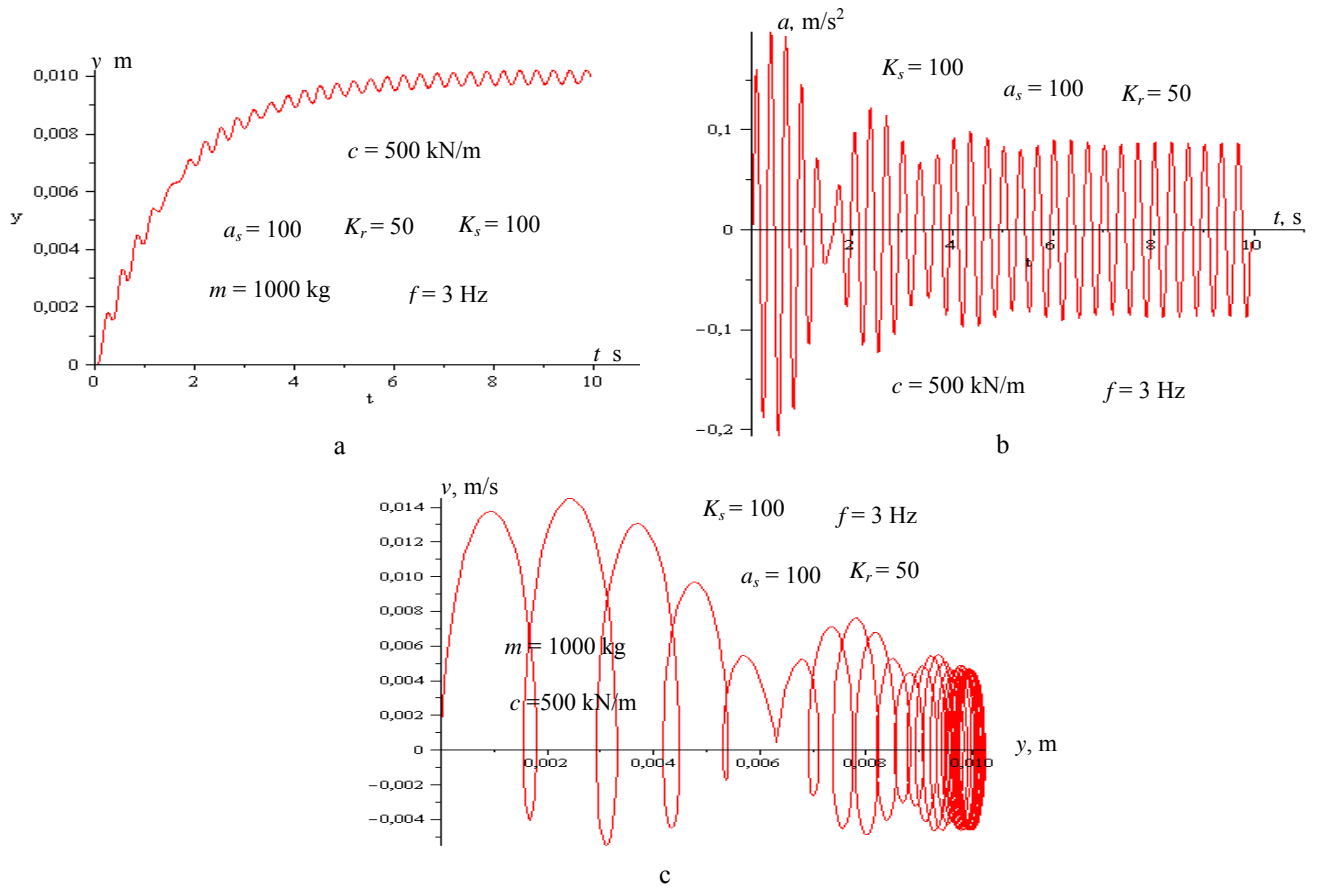

Fig. 11 Frequency characteristics of displacement (a), the acceleration (b) and plane trajectory (c) for regulated system and frequency  $f = 3 \text{ Hz}$

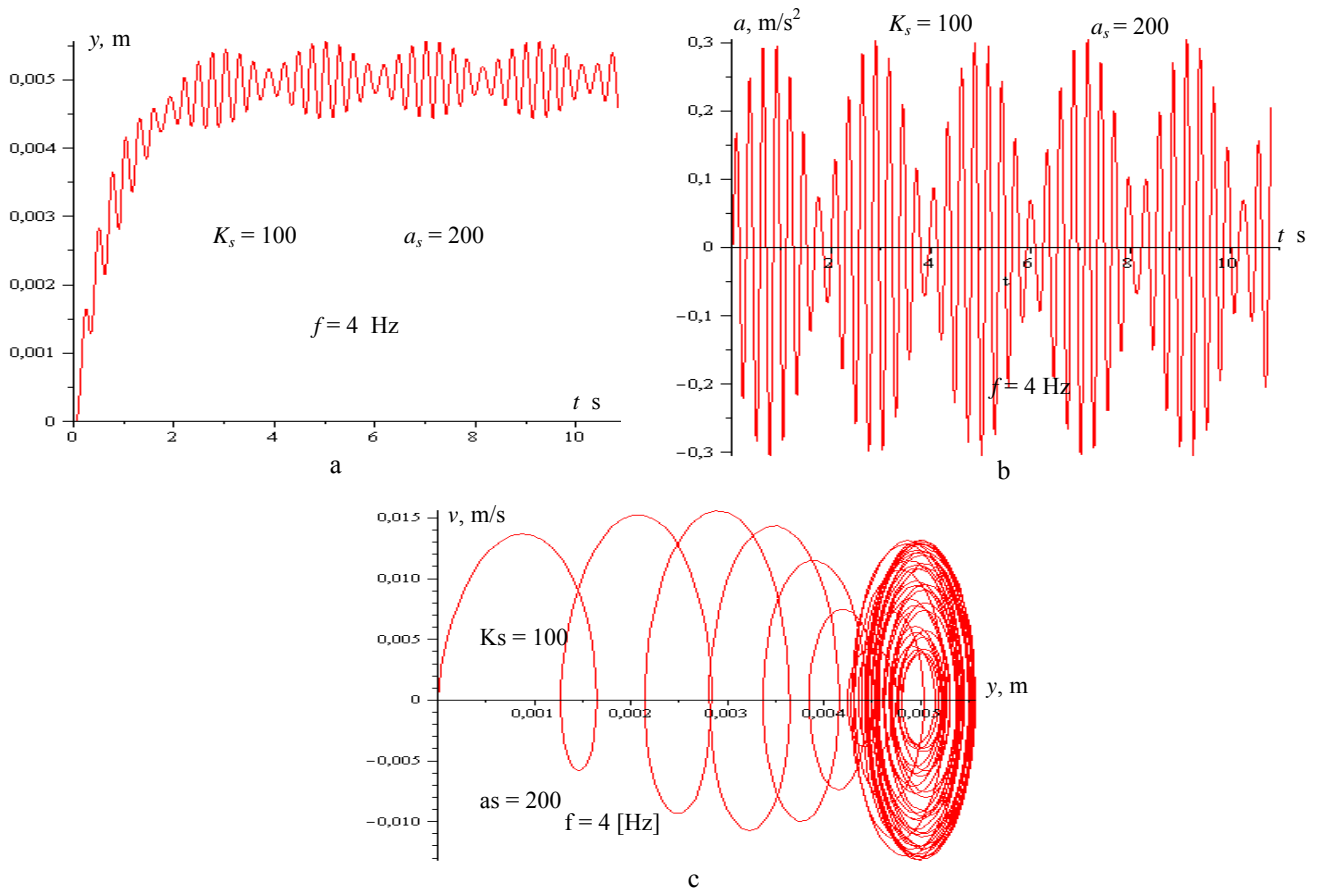

Fig. 12 Courses of displacement (a), the acceleration (b), the plane trajectory (c) for regulated system and frequency  $f = 4 \text{ Hz}$

## 6. Conclusions

Module system with build in dynamical signal regulator behave stabile. Stabilization of the system with dynamical regulation is shown in figures. Because of in-built of dynamical signal regulator it is possible to achieve state in the system where parameters reach asymptotic values. In further scientific research it is expected to built an algorithm of genetic optimization. In conclusion the main algorithm based on derives analysis for module systems, which enables free regulation of module systems for optimal setting.

## References

1. **Szafran, J. Wiszniewski, A.** Decision and Measurement Algorithms of Electro Energetic Cyber Automatics -Warszawa: WNT, 2001.-324p. (in Polish).
2. **Jagiello, A.S.** Integral Transformations in Electric Machines Theory. -Warszawa: Science Publishing PWN, 2002.-148p. (in Polish).
3. **Bubnicki, Z.** Theory and Control Algorithms. -Warszawa: Science Publishing PWN, 2005.-304p. (in Polish).
4. **Graham, L. Knuth, D.E. Patashnik, O.** Concrete Mathematics. -Massachusetts: Addison-Wesley, 1994.-657p.
5. **Kaczmarek, K. Nowak, A.** Networks Analysis and Optimization. -Gliwice: Silesian Technical University Publishing, 2007. -176p. (in Polish).
6. **Brzózka, J.** Regulators and Automatics Systems. -Warszawa: Science and Technical Publishing, 2004.-337p. (in Polish)
7. **Kaczorek, T.** Automatic Regulation Systems Theory. -Warszawa: Science and Technical Publishing, 1977.-500p. (in Polish).
8. **Osiński, Z.** Vibration Theory. -Warszawa: Science and Technical Publishing, 1998.-330p. (in Polish).
9. **Nowak, A. Kaczmarek, K.** Optimization of the vibroisolation systems of crane cabin using genetic algorithms. -Mechanika. -Kaunas: Technologija, 2007, p.103-111.
10. **Nowak, A.** Optimization of the active vibroisolation system UWKS for crane cabin by use of the genetic algorithm. -Acta Mechanica Slovaca. -Kosice, 2007, 4-A, p.157-164.

A. Nowak, M. Wozniak

## DAUGIAPAKOPĖ MODULINIŲ MECHATRONINIŲ SISTEMŲ ANALIZĖ

### R e z i u m ė

Šiame straipsnyje aprašoma modulių mechatroninių sistemų su PID tipo aktyviuoju reguliavimo elementu daugiapakopė analizė. Analizuojamos aktyviosios mechatroninės sistemos modeliavimas su grįžtamojo ryšio valdymo posistemiu. Aprašomas algoritmas taikomas modulinei sistemai su regulatoriumi, kuris pirmasis modulis yra įrenginys, skirtas elektrai tiekti, o antrasis – modeliuojamas grįžtamojo ryšio valdymo posistemis. Naudojant MAPLE programinę įrangą atlikti modulio dinamių charakteristikų tam tikri skaičiavimai.

A. Nowak, M. Woźniak

## MULTIRESOLUTION DERIVES ANALYSIS OF MODULE MECHATRONICAL SYSTEMS

### S u m m a r y

This article presents multiresolution derives analysis for examples of circuit with module structure and with power regulator type PID. There the study of the modelling of the active mechatronical systems with control feedback subsystem is shown. Algorithm is illustrated for module system with regulator, where first module is set for electrical transmitter and the other is modelling control feedback. Particular calculations were made with MAPLE calculation system for determine of the dynamical characteristics of the module system with vibroisolator.

A. Новак, М. Возняк

## МНОГОСТУПЕНЧАТЫЙ АНАЛИЗ МОДУЛЬНЫХ МЕХАТРОННЫХ СИСТЕМ

### Р е з ю м е

В работе описан многоступенчатый анализ модульных мехатронных систем с активными элементами регулировки типа ПИД. В ней анализируется моделирование активной мехатронной системы с управляющей обратной связью. Представленный алгоритм предназначен для модульной системы с регулятором, где первым модулем является устройство для подачи электричества, а вторым – подсистема с моделированной управляющей обратной связью. Расчеты, связанные с определением динамических характеристик модуля производились с помощью программы MAPLE.

Received April 02, 2008

Accepted September 30, 2008

DOI: 10.5755/j02.mech.15177