

# Influence of chemical composition and structure on the properties of overlay welded structural steel

P. Ambroza\*, T. Pilkaitė\*\*, S.J. Chodočinskas\*\*\*

\*Kaunas University of Technology, Kestucio 27, 44312 Kaunas, Lithuania, E-mail: petras.ambroza@ktu.lt

\*\*Kaunas University of Technology, Kestucio 27, 44312 Kaunas, Lithuania, E-mail: tilma@ktu.lt

\*\*\*Kaunas University of Technology, Kestucio 27, 44312 Kaunas, Lithuania, E-mail: sangau@ktu.lt

## 1. Introduction

Surface condition of structural components has been a persistent problem in modern engineering applications. Using cladding techniques, it is possible to improve surface properties, such as wear, corrosion and oxidation resistances and to take advantages of a long service life and the consequent reduction of total cost. Submerged arc cladding has been used in modern industries, especially for heavy section steels and for large structure surfaces needing to be modified [1, 2].

In submerged arc welding, there are several ways of increasing welding efficiency. The following are known as multiple-wire welding, multiple-electrode welding, hot wire welding and welding with metal powder addition [3].

The influence of composition and heat treatment of overlays on abrasive wear resistance of iron base hard facing alloy overlays is reported in work [4]. Overlays were deposited on structural steel by using shielded metal arc (SMA) welding process using two commercial hard facing electrodes, i.e. Fe – 6%Cr - 0.7% C and Fe - 32% Cr – 4.5% C. It was found that wear resistance of high Cr-C coating is better than low Cr-C hard facing under identical conditions. Post – weld heat treatment enhanced abrasive wear resistance.

Fe-C-Cr weld surfacing layers with different compositions and microstructures can be obtained by submerged arc welding with welding wire of low carbon steel and high alloy bonded flux [5]. With the increase of Cr and C in layers, the microstructure is changed from hypereutectoid steel to hypereutectic iron. The experimental results lay a foundation to make double-metal percussive plates by surfacing wear resistant layers in the substrates of low carbon steel.

The microstructure and high temperature stability of an iron-based hard facing alloy of nominal composition Fe-30Cr-3.8C (weight percents) deposited by manual metal arc welding has been investigated using microscopy, microanalysis, dilatometry and thermodynamic modeling [6]. In the as-deposited condition, the undiluted alloy was confirmed to consist of a mixture of  $M_7C_3$  carbide and metastable austenite containing high chromium concentration. Since the properties of alloy can depend on the stability of austenite. Annealing experiments were carried out to investigate the decomposition of austenite into a mixture of ferrite and carbides. The results demonstrate that at temperatures around 750°C the austenite starts to decompose rapidly, beginning either the precipitation of  $M_{23}C_6$  carbides, although the final equilibrium phase mixture is simply chromium – depleted ferrite and  $M_7C_3$ .

In work [7] the abrasive wear behavior of hypereutectic and hypoeutectic based Fe-Cr-C hard facing are reported and integrated in terms of microstructures. The coatings were deposited onto a grey cast iron substrate by shielded metal arc welding using two commercial hard facing electrodes. It was found that hardness of hypereutectic coating was significantly higher than the hardness of hypoeutectic coating. In both cases, optimum hardness was achieved within the first deposited layer. The abrasion tests showed that there was no significance difference in wear resistance of hard facing at higher loads and there was contrasting wear behavior in dry and slurry conditions.

Various methods of overlay welding for steels are used. The simple technology of arc welding (manual automatic under the flux or in protective gas) enables to obtain the hard and wear resistance layers. The seamless and powder wire, powder of alloying elements are used for arc welding to obtain an alloyed layer.

In presented work, the structural grade 45 steel was overlay welded using powder electrodes by arc welding method under the coating of flux.

The purpose of this work is to investigate the structure, properties and wear resistance of overlay welded layers by using powder electrodes with carbon, chromium and P6M5 steel powder filling.

## 2. Testing procedure

Specimens for the investigation of microstructure, measurement of hardness, heat treatment and cutting punches were made from structural grade 45 steel (0.42-0.5% C, 0.17-0.37% Si, 0.5-0.8% Mn) overlay welded with powder electrodes under the flux AH-348M (%):  $SiO_2$  41-44;  $MnO$  34-38; CaO up to 6.5;  $Al_2O_3$  up to 4.5;  $CaF_2$  4.5-5;  $Fe_2O_3$  up to 20.

The powder electrodes were manufactured from low carbon 0.2 mm thickness steel tin coating and powder mixture filling which contain the powder of graphite, chromium and P6M5 steel powder. Drills grinding wastes were cleaned with solvent from oil, then dried out at 150°C temperature and used as P6M5 steel powder.

The specimens were overlay welded with suspended automatic device having special movable part for powder electrodes. Welding current – 250 A, welding speed – 0.22 m/min, support of electrode – 0.9 m/min.

Digital metallographic method was used for the investigation of microstructure of overlay welded layers. This method allows to precisely evaluating microstructure of layer. For microstructure evaluation, digital code of microstructure was obtained using digital video camera YCH

15 and treated by computer information equipment Video Kit SE100 [8].

Chemical composition of overlay welded layer was performed by mass-spectrometer and micro-laser analyzer which enabled to fix changes of chemical composition of overlay welded layer in its whole depth.

Wear investigations of overlay welded specimens were performed by wear determining die [9], which is presented in Fig. 1.

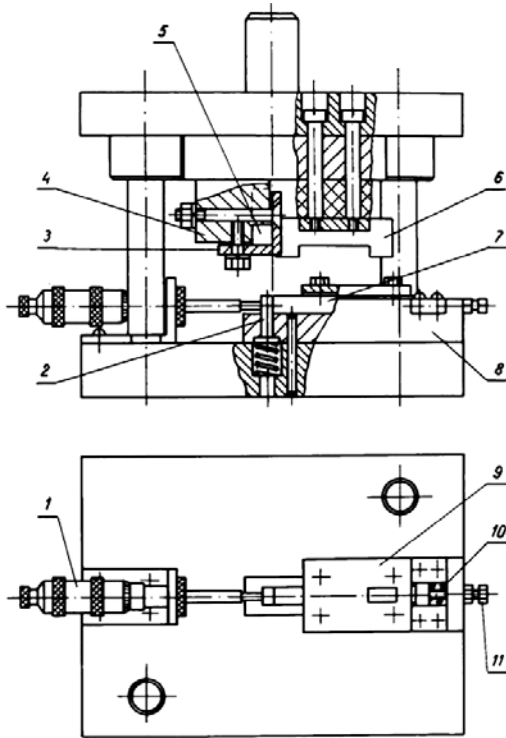

Fig. 1 Wear determining die: 1 - micrometer screw; 2 - movable support; 3 - specimen attaching goke; 4 - specimen holder; 5 - specimen; 6 - clamp of cutting strip; 7 - matrix; 8 - matrix holder; 9 - cap; 10 - spring; 11 - adjustable support screw

Overlay welded specimen with perpendicularly grinded cutting edge was attached in the die specimen holder and it cut cyclically moving 0.5 mm thickness electrical-sheet steel strip. Seeking to eliminate the influence of matrix wear on the wear of overlay welded specimen its cutting part was made from hard alloy. Overlay welded specimen wear was evaluated by geometrical change of cutting edge. Wear of punches edge and rake surface was measured by microscope. Wear measurement scheme is shown in Fig. 2.

Retained austenite amount of overlay welded layer specimens in the surface layer was determined by roentgen diffractometer URS-501 using the lamp with iron anode. The amount of retained austenite was determined according to V.A. Landau methodology, using the formula:

$$A = \left( \frac{3B}{B+2} \right) 100$$

where  $B = \frac{h_\gamma}{h_\alpha + h_\gamma}$ ,  $A$  is amount of retained austenite, %;

$h_\gamma$  is peak point of austenite (311) on X-ray diagram, mm;  
 $h_\alpha$  is peak point of ferrite (110) on X-ray diagram, mm.

Hardness of materials shows generally their mechanical properties so hardness measurements were used for their determination. Microhardness was measured perpendicularly to the overlay welded zone by 0.02 mm interval.

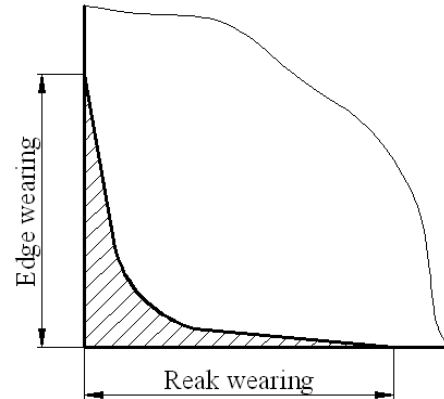

Fig. 2 Scheme of punches wearing

### 3. Results of the investigation

Alloying layers with the chromium, silicon, manganese, molybdenum, vanadium and tungsten was obtained by overlay welding the structural grade 45 steel with powder electrodes containing carbon, chromium and drills grinding wastes grade P6M5 steel powder in (Table 1).

The amount of chromium and carbon in layers depends on the amount of elements in powder electrodes filling. Additionally, the layers were alloyed by molybdenum, vanadium and tungsten contained into grade P6M5 steel powder. A part of alloying elements contained in grade P6M5 steel powder burnt out in high arc temperature, and furthermore, on drills grinding process, separate small fractions of grade P6M5 steel heat up to high temperature and because of burning of an alloying elements, their amount decreased. Overlay welded layer was alloyed additionally by chromium and carbon contained in this powder. Manganese and silicon from liquid slag passed to the layer, because basic flux elements  $\text{SiO}_2$  and  $\text{MnO}$  were used.

On cooling under the flux and liquid slag, the alloyed layers were hardened. Hardness of overlay welded layers is shown in Table 2.

The structure was formed of martensite, trostite, carbides and retained austenite because cooling process of the overlay welded layers is slow.

Hardness of overlay welded layers depends on the amount of structural phases. Tempering of the layers at 500-600°C temperature causes decrease of hardness, except the layer overlay welded by electrode containing 10% graphite and 25.0% chromium. Hardness of the layers increases from 46 to 55 HRC after tempering at 500°C temperature. The first three layers were low alloyed and contained not enough of carbon for proceeding of secondary hardening. The layers are not resistance to heat condition, so, welded structural steel 45 investigated using chosen powder electrodes, can be used for parts or tools which at the time of its exploitation heats up to low temperatures.

Table 1

Chemical composition of overlay welded layers

Composition of electrodes filling, %			Amount of elements, mass %							
C	Cr	P6M5	C	Si	Mn	Cr	Mo	V	W	Fe
6.0	25.0	69.0	0.44	0.98	1.93	3.8	0.63	0.15	0.98	Remainder
8.0	20.0	72.0	0.57	0.86	1.81	2.24	0.49	0.09	0.93	
10.0	15.0	75.0	0.63	0.88	1.90	2.09	0.62	0.15	0.96	
10.0	25.0	65.0	0.65	1.01	2.01	4.30	0.67	0.17	1.02	

Table 2

Influence of tempering temperature on the hardness (HRC) of overlay welded layers

Composition of electrodes filling, %			Tempering temperature, °C			
C	Cr	P6M5	Without tempering	500	550	600
6.0	25.0	69.0	57	51	43	37
8.0	20.0	72.0	52	44	42	34
10.0	15.0	75.0	55	52	47	41
10.0	25.0	65.0	46	55	48	41

Microstructures of overlay welded layers are similar to each other (Fig. 3). Carbide phase is low in the layers, but in all tested layers by roentgen-structure method

the different amount of retained austenite (from 12 to 37%) was determined.

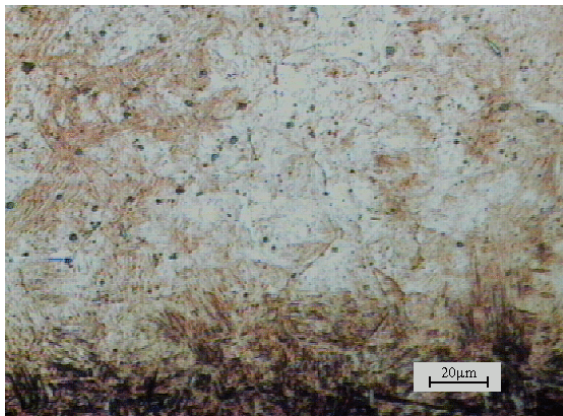

a

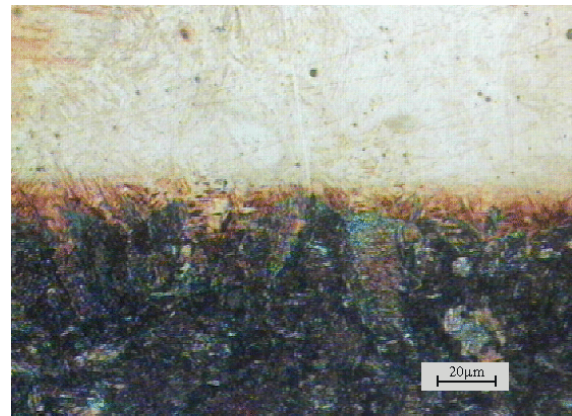

b

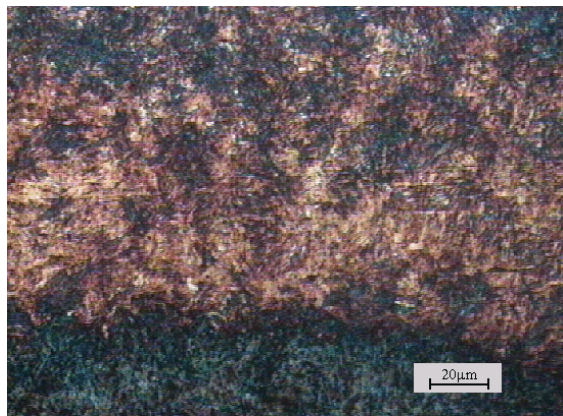

c

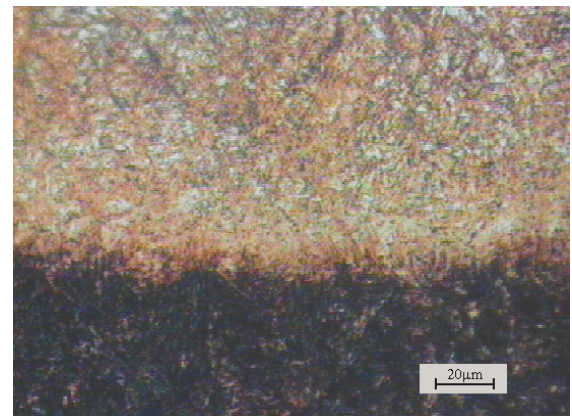

d

Fig. 3 Microstructures of layers overlay welded with powder electrodes containing: a – 6%C, 25%Cr; b – 8%C, 20%Cr; c – 10%C, 15%Cr; d – 10%C, 25%Cr. Additionally, grade P6M5 steel powder was put into electrodes

Durability of punches manufactured from overlay welded grade 45 steel was determined by cutting of steel plates.

The punches after heating at 850°C temperature were hardened by cooling them in to oil and then tempered

at 150°C temperature. Hardness of the layers of 55-57 HRC units was obtained the amount of retained austenite in layers was from 12 to 37%.

For comparison of testing results, one punch was manufactured from standard XBF steel (Table 3).

Table 3

Wearing of overlay welded punches depending on the number of blows

Composition of electrodes filling, %			Amount of retained austenite, %	Number of punch blows, x1000				Wearing	Number of specimen
C	Cr	P6M5		5	10	15	20		
6.0	25.0	69.0	37.0	0.0025	0.011	0.018	0.02	Edge	1
				0.002	0.009	0.012	0.018	Rake	
8.0	20.0	72.0	14.0	0.024	0.04	0.043	0.052	Edge	2
				0.015	0.025	0.03	0.031	Rake	
10.0	15.0	75.0	27.0	0.01	0.019	0.022	0.028	Edge	3
				0.003	0.01	0.015	0.018	Rake	
10.0	25.0	65.0	12.0	0.01	0.02	0.027	0.032	Edge	4
				0.008	0.018	0.021	0.023	Rake	
Standard steel XBF				0.03	0.045	0.055	0.059	Edge	XBF
				0.021	0.038	0.042	0.049	Rake	

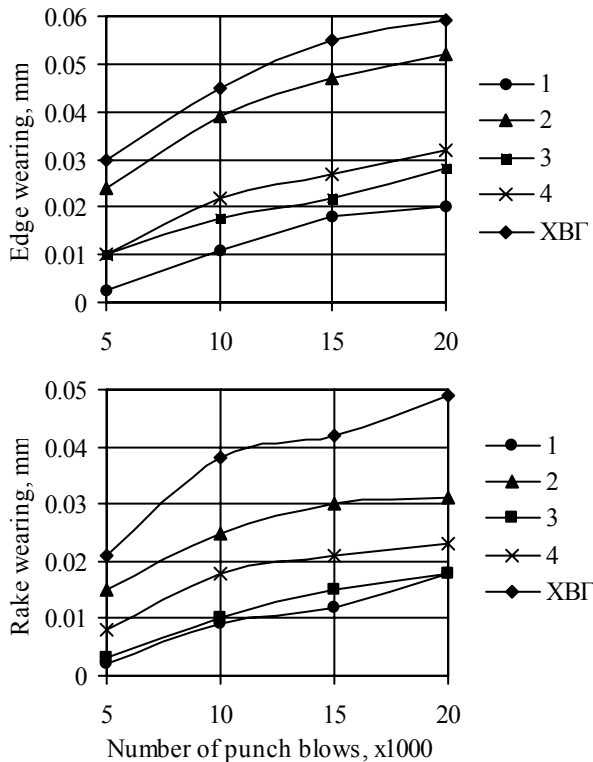

Fig. 4 Wearing of overlay welded punches depending on the number of blows

Wear resistance of steel depends on its structure and hardness. Testing of the punches was performed by experimental stamp. Hardness of the punches was similar, but the amount of retained austenite differed widely.

The punch overlay welded with electrode containing 6%C, 25Cr % and 69% grade P6M5 steel powder filler wore less (Table 3, Fig. 4). This layer contained 37% of retained austenite and wore at least. That allows confirming that this amount of retained austenite increases wear resistance. The punch overlay welded with electrode containing the 10%C, 25%Cr and 65%P6M5 steel powder filler wore less though the amount of retained austenite

in the overlay welded layer was 12%. This might be explained by greater amount of carbon, chromium and carbides increase resistance to wear. The overlay welded punches wore less in comparison with the punches manufactured from standard XBF steel. Depending on the composition of powder electrodes filler, wear resistance of overlay welded punches is higher twice than of the punches manufactured from XBF steel.

#### 4. Conclusions

1. Alloyed layers containing tungsten and molybdenum were obtained by using P6M5 steel powder manufactured from drills grinding wastes. Tungsten and molybdenum are basic elements for alloying tool steels. That is a good possibility to save expensive tungsten and molybdenum industrial production powder.

2. The layers with the hardness of 57 HRC units but with different amount of retained austenite were obtained by overlay welding of structural steel 45 with powder electrodes containing grade P6M5 steel, chromium, and graphite powder filler under the flux.

3. The testing results of experimental stamp show that the overlay welded layers are resistant to impact loads. Retained austenite has an influence on wearability of layers with the same hardness. Wear resistance of the layers containing more retained austenite is higher. The layers containing more carbide wore less, too.

#### References

1. **Shan-Ping Lu, Oh-Yang Kwon, Tal\_Bum Kim, Kwon-Hu Kim.** Microstructure and wear property of Fe-Mn-Cr-Mo-V alloy cladding by submerged arc welding. -J. of Materials Processing Technology, 2004, v.147, issue 2, p.2-6.
2. **Jankauskas, V., Kreivaitis, R.** Study of wear prediction by applying surface microgeometric parameters. -Mechanika. -Kaunas: Technologija, 2007, No.5(67), p.65-70.

3. **Tušek, J., Suban, M.** High productivity multiple wires submerged arc welding and cladding with metal powder addition. -J. of Material Processing Technology, 2003, v.133, p.207-213.
4. **Dwivedč, D.K.** Microstructure and abrasive wear behavior of iron base hard facing.-Materials Science and Technology, 2004, v.20, p.1326-1330.
5. **Ren, Z., Xuan, Z., Sun, D.** Erosion resistance of Fe-C-Cr weld surfacing layers.-China Welding (English Edition), 2001, v.10, issue 1, p.8-13.
6. **Atamert, S. and Bhadeshia, H.K.D.A.** Microstructure and stability of Fe-Cr-C hard facing alloys. -Materials Science and Engineering, 1990, v.130, issue 1. p.101-111.
7. **Buchanan, V.E., Shipway, P.H., McCartney, D.C.** Microstructure and abrasive wear behavior of shielded metal arc welding hard facing used in sugarcane industry. -Wear, 2007, v.263, p.99-110.
8. **Bendikienė, R.** Investigation of carbide phase morphology in to microstructure of casted and rolled steel. -Mechanika. -Kaunas: Technologija, 1999, No.5(20), p.64-68.
9. **Chodočinskas, S.** Investigation of the Influence of Microstructure, Heat and Chemical Heat Treatment on Wear Resistant of Punch.-Doctoral Dissertation.-Kaunas: Technologija, 1992, p.9-23.

P. Ambroza, T. Pilkaitė, S.J. Chodočinskas

#### CHEMINĖS SUDĖTIES IR STRUKTŪROS ĮTAKA APVIRINTO KONSTRUKCINIO PLIENO SAVYBĖMS

##### Reziumė

Darbe ištirta lankinių būdu milteliniais elektrodais po flisu apvirinto plieno 45 struktūra ir savybės. Miltelinių elektrodų užpildui panaudoti plieno P6M5 milteliai, išskirti iš gražtų šlifavimo šlamo, bei chromo ir grafito pramoninės gamybos milteliai. Apvirintų sluoksnių struktūra ir savybės ištirtos metalografiniu ir rentgenografiniu būdais, matuojant kietumą, spektrine analize nustatant cheminę sudėtį. Eksperimentiniu štampu nustatytas apvirintų puansonų patvarumas. Karpant elektrotechninį plieną, apvirinti puansonai, palyginti su įrankiniu plienu ХВГ, dilo mažiau.

P. Ambroza, T. Pilkaitė, S.-J. Chodočinskas

#### INFLUENCE OF CHEMICAL COMPOSITION AND STRUCTURE ON THE PROPERTIES OF OVERLAY WELDED STRUCTURAL STEEL

##### Summary

In presented work the structure and properties of overlay welded structural grade 45 steel by using arc welding method under the coating of the flux was investigated.

Drills grinding wastes of grade P6M5 steel powder, chromium and graphite industrial production powder were used for powder electrodes filler. The structure and properties of the layers was investigated by using metallographic, roentgen-structure methods, measurements of hardness. Chemical composition of overlay welded layer was obtained by spectral analysis. Wear investigations of overlay welded punches were performed by using experimental stamp.

The overlay welded punches in accordance with wear testing results is higher twice than of punches manufactured from grade ХВГ steel.

П. Амброза, Т. Пилкайте, С.-Й. Ходочинскас

#### ВЛИЯНИЕ ХИМИЧЕСКОГО СОСТАВА И МИКРОСТРУКТУРЫ НА СВОЙСТВА НАПЛАВЛЕННОЙ КОНСТРУКЦИОННОЙ СТАЛИ

##### Резюме

В работе исследована структура и свойства конструкционной стали 45, наплавленной порошковыми электродами дуговым способом под флюсом. Для заполнителей порошковых электродов был использован порошок стали P6M5, полученный из шлама шлифования сверл, а также порошок хрома и графита промышленного производства. Структура и свойства наплавленных слоев исследованы металлографическим, рентгенографическим способами, измерением твердости, спектральным анализом химического состава. Экспериментальным штампом определена стойкость наплавленных слоев. Наплавленные пуансоны при резке электротехнической стали меньше изнашивались по сравнению с пуансоном, изготовленным из инструментальной стали ХВГ.

Received September 11, 2008

Accepted October 24, 2008

DOI: 10.5755/j02.mech.15178