

# Basic aspects concerning modular design of reconfigurable parallel manipulators for assembly tasks at nanoscale

R. Pacurari\*, A. Csizar\*\*, C. Brisani\*\*\*

\*Technical University of Cluj-Napoca, C. Daicoviciu 15, 400020 Cluj-Napoca, Romania,  
E-mail: radu.pacurari@yahoo.com

\*\*Technical University of Cluj-Napoca, C. Daicoviciu 15, 400020 Cluj-Napoca, Romania,  
E-mail: ak0s@yahoo.com

\*\*\*Technical University of Cluj-Napoca, C. Daicoviciu 15, 400020 Cluj-Napoca, Romania,  
E-mail: Cornel.Brisan@mmfm.utcluj.ro

## 1. Introduction

Most existing precision assembly robots are very expensive, so there is a clear need for simple, cost-effective assembly automation. There is a trend to place the complete assembly system inside of a clean room environment, leading to the requirement for very compact, modular assembly automation. Until now, there have been developed a variety of different technical solutions for dealing with the above mentioned trends.

The state of the art for precision robots can be summarized as shown in Fig. 1.

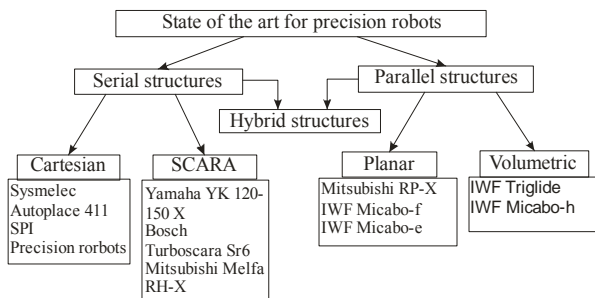

Fig. 1 Classification of precision assembly / manipulation robots

The simplest classification is into serial, parallel and hybrid structures, which in turn can be subdivided into further categories [1].

The first category covers Cartesian robots. These are typically very large in comparison to their components to be handled and are often as a result, very expensive. However, they do provide repeatability between 1 and 3 micrometers, as demonstrated by, for example, the "Sysmelec Autoplance 411".

The second category covers SCARA robots, which have a large workspace in relation to their physical size, but only achieve a repeatability of  $\pm 5$  micrometers, even in the case of the most accurate designs. In the field of parallel robots, there are few examples in industrial use. The Mitsubishi RP-X is an exception, achieving a repeatability of  $\pm 5$  micrometers. The majority of developments in this area are limited to university research projects, for example with the Triglide robot [2], which has achieved a better repeatability than 1 micrometer.

These existing solutions have the common feature of being very expensive and very large and there is now growing market demand for smaller, cheaper robotic de-

vices for positioning, manipulation and assembly. The development of such robots is now being made possible by new enabling technologies, in particular zero-backlash microgears and highly dynamic micro-motors with integrated incremental encoders, which are allowing proven robot arm structures to be miniaturized.

The trend to miniaturization is leading to yearly growth of the world market for products based on micro-system technology of 20% and therefore the interest in microproduction technologies is also increasing [3].

Let NaHybMan be the name of the Hybrid robot for Nano Manipulation. It consists of two important components (Fig. 2). The first one is a parallel reconfigurable component which is able to succeed operations with micrometer precision and have the role of assuring the positioning and orienting of the mobile platform. Let NaPaMan (Nano Parallel Manipulator) be the name of this component. The second one is a serial component constituted with the use of piezo actuators and is capable to realize operations with nanometer precision. After assembling the whole system, it is capable of achieving operations with nanometer precision.

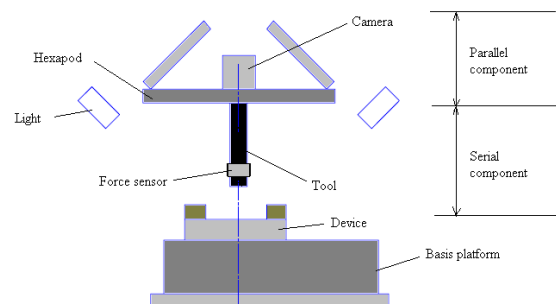

Fig. 2 The NaHybMan model

As it was mentioned above, the NaHybMan robot variant is able of achieving micrometer precision operations through its parallel component and it gets to achieve nanometer precision operations through its serial component. Because the object that is supposed to be manipulated may have very small dimensions, even unobservable dimensions, this must be localized first based on its physical or chemical properties. Therefore, NaHybMan will have to "follow" these properties until the detection is taking place, a fact that implies the satisfaction of gripping conditions. Thus results the novelty character in the means of mathematical model which has to be developed similarly to tracking systems. Therefore, a sensorial system must be

also considered in order to “search” the volume where the manipulated object is predicted to be located.

The main goal of this paper is to develop mathematical and virtual models for a new class of parallel reconfigurable robots (NaPaMan) that are designed with the purpose to be used for nanomanipulation and/or nanoassembly.

## 2. Theoretical aspects

Structural synthesis of parallel mechanisms could be made if the relation of the number of degrees of freedom (DOF) is considered

$$M = (6 - m)n - \sum_{k=1}^5 (k - m)C_k - M_p \quad (1)$$

where  $m$  is the number of common constrains for all elements,  $n$  is the number of the mobile elements,  $k$  is the number of constrains which define a joint,  $C_k$  is the number of joints with  $(6 - k)$  degrees of freedom and  $M_p$  is the number of identical degrees of freedom.

In the case of parallel mechanisms without common constrains and also without identical degrees of freedom the relation (1) becomes

$$M = 6n - \sum_{k=1}^5 kC_k \quad (2)$$

Let  $N$  be the number of mobile platforms and  $D_k$  – the number of joints with  $(6 - k)$  degrees of freedom which directly connect the platforms of the mechanism. With these notations it results

$$M = 6(n_1 + N) - \sum_{k=1}^5 k(C_k + D_k) \quad (3)$$

where  $n_1$  is the number of the elements which compose the loops which connect the platforms of the mechanism.

We can also assume three types of basic modules (named basic legs) which can connect the platforms of the mechanism [4]. Let  $a_1$  be the number of the loops with prismatic – universal – spherical (PUS) topology, let  $a_2$  be the number of the loops with prismatic – rotational – spherical (PRS) topology, and also let  $a_3$  be the number of the loops with prismatic – 2 universal – 2 spherical (P2U2S) topology.

In the case of parallel mechanisms which are used in the field of manipulation and/or assembly operations, it is common to consider

$$N = 1, D_k = 0, k = \{1, \dots, 5\} \quad (4)$$

With these notations, the relation (3) becomes

$$M = 6 - a_2 - 3a_3 \quad (5)$$

Also, each loop contains only one degree of freedom. Thus, it results

$$M = a_1 + a_2 + a_3 \quad (6)$$

Integer solutions of the equations

$$\begin{cases} M - 6 + a_2 + 3a_3 = 0 \\ a_1 - M + a_2 + a_3 = 0 \end{cases} \quad (7)$$

gives all variants of parallel mechanisms with assumed hypothesis.

The system of Eqs. (7) has many solutions. Also, if other parameters are taken into consideration (the order of the joints in the loop, geometrical parameters of the loops, etc) the topology problem becomes very complex. The relation (7) defines the topology of parallel robots in a modular manner. Table presents variants of NaPaMan robots, solutions of (7), with  $a_3 = 0$  and  $6 \geq M \geq 3$ .

Table  
Solutions for NaPaMan robots

No	$M$	$a_1$	$a_2$	Remarks
1	6	6	0	Stewart Platform
2	5	4	1	
3	4	2	2	
4	3	0	3	

Also, Fig. 3 presents kinematic loops of those variants (Fig. 3, a – robots with 6 DOF, Fig. 3, b – robots with 5 DOF, Fig. 3, c – robots with 4 DOF, Fig. 3, d – robots with 3 DOF). The major advantage when using this type of displacement of the joints consists in the fact that the weight of the moving masses is smaller. This happens because the actuators are directly connected to the fixed platform.

For a different order of the joints in the loop, the variants shown in Fig. 4 are obtained: Fig. 4, a – robot with 6 DOF, Fig. 4, b – robot with 5 DOF, Fig. 4, c – robot with 4 DOF, Fig. 4, d – robot with 3 DOF. The most important advantage when using this type of topology is elimination of the guides of the actuators mobile elements (actuator rod guide). This type of NaPaMan robots will be named “NaPaMan – hexapod type”.

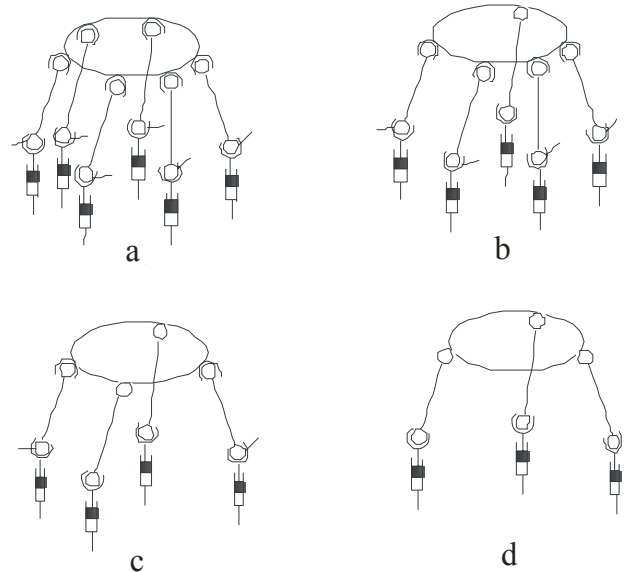

Fig. 3 Variants of NaPaMan with fixed actuators: a – 6 DOF, b – 5 DOF, c – 4 DOF, d – 3 DOF

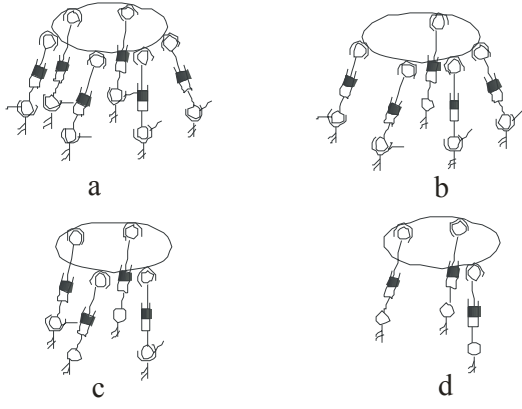

Fig. 4 Variants of NaPaMan – hexapod type: a – 6 DOF, b – 5 DOF, c – 4 DOF, d – 3 DOF

### 3. Kinematics

General algorithms used to solve direct kinematics in the case of parallel mechanisms consider that for each independent loop of the mechanism one vector equation can be written [5, 6]. Thus, a nonlinear system of scalar equations is obtained. Usually, this system of equations can be solved only with numerical methods and for that an accurate initial value of the solution is required. Of course, this initial value of the solution is strongly related to geometrical parameters of the mechanism. When the geometric parameters of the mechanism are changed also the initial solution must be changed. According to that, the kinematics of the parallel mechanism will be developed in a modular manner, based on kinematics of the legs which connect the platforms and in order to ensure an analytical value for the initial solution. Each leg is in fact the right (or left) side of one independent closed loop and can be described by two coordinate systems: one attached to the frame and the other one attached to the mobile platform (Fig. 5).

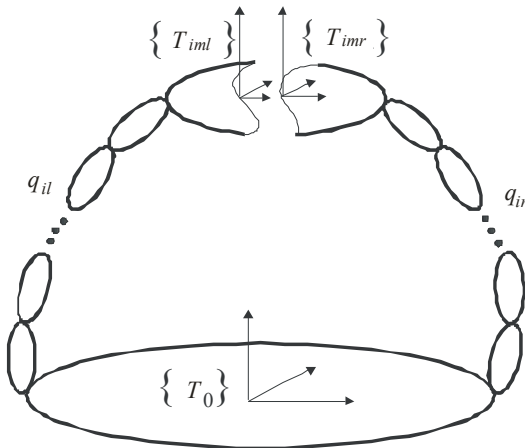

Fig. 5 “Cut body” method

where  $T_0$  is fixed coordinate system,  $T_{iml}$  is coordinate system attached to the last element of the left side of the “ $i$ ” independent loop,  $T_{imr}$  is coordinate system attached to the last element of the right side of the “ $i$ ” independent loop.

The relationship between these coordinate systems is given by

$$H_{iml} = \prod A_{il}(q_{il}) \quad (8)$$

for the left part of the independent loop and

$$H_{imr} = \prod A_{ir}(q_{ir}) \quad (9)$$

for the right part.  $H_{iml}$ ,  $H_{imr}$  are absolute transformation matrices and  $A_{il}(q_{il})$ ,  $A_{ir}(q_{ir})$  are relative transformation matrices.

For an independent loop it results

$$H_{iml} = H_{imr} \quad (10)$$

Matrix (10) leads to six independent scalar equations. For the whole parallel mechanism, a nonlinear system of equations (with  $6n$  independent scalar equations, where  $n$  is the number of independent loops) will be obtained. This system of equations can be solved only with numerical methods. Generally, the legs of the parallel component have the same topology. It results that the relative transformation matrices for the left and right part of each loop are formally similar. Therefore, for each topology of the legs, a formal mathematical entity (named LMM - Leg Mathematical Model) was developed. Similarly a modular kinetostatic model was also developed. This mathematical model leads to nonlinear system of equations. Classic algorithms of numerical methods, e.g. Newton-Raphson, can be used in order to solve this system of equations.

### 4. Control algorithm

The control algorithm, that was developed, has as goal to assure a precise ( $1\mu\text{m}$ ) positioning and orienting of the mobile platform for the NaPaMan part, and even more precise positioning for the whole NaHybMan structure. In Fig. 6, the control concept for the NaPaMan part is presented. This concept is hybrid force – position control algorithm and was developed in correlation with the overall concept for the whole structure, in a modular manner.

As any complex control system this is also built up from interconnected elements.

A PC deserves the role of a human machine interface (HMI). The input from the user comes from this PC. For convenience, the input data can be introduced in multiple ways: numerical input from keyboard; incremental input from keyboard; via joystick, with force feedback; using the mouse, with less precision.

The input variables are Cartesian coordinates of the end effector of NaHybMan or of the mobile platform of NaPaMan. For force controlled applications the forces constraints (and/or maximum force limits) will be introduced.

Also the graphical user interface (GUI) displays a 3D representation of the manipulator, and plotting coordinates (both Cartesian and motor positions) versus time is possible. The response from the force sensors is also visualized here.

For position control the solution for inverse kinematics problem is necessary. Force distributions for different actuators are obtained based on the stiffness matrix

$$K = \frac{F}{X} \quad (11)$$

where  $K$  is the stiffness matrix,  $F$  is the generalized force that actuates the mobile platform,  $X$  is the generalized displacement of the mobile platform.

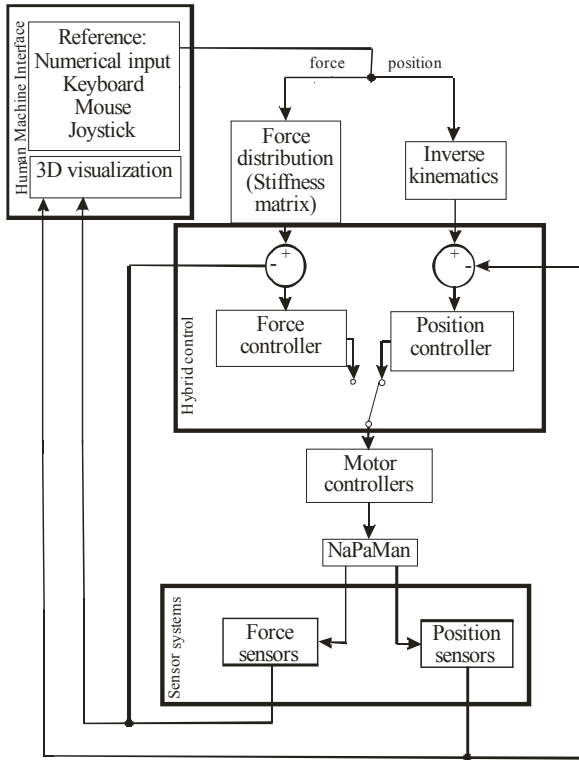

Fig. 6 Control concept

Hybrid control is necessary for very high precision manipulation. This type of control is based on the existence of a rapid commutation between force and position control.

These control strategies generate the input values for the actuator controllers. Motor controllers are devices that govern the electric motors. A motor controller might include a manual or automatic means for starting and stopping the motor, selecting forward or reverse rotation, selecting and regulating speed, regulating or limiting torque, and protecting against overloads and faults.

High precision linear motors assure reliable motion of the manipulator.

Feedback from the manipulator for closed loop control comes from high precision sensors, both for position and force.

## 5. Implementation

Implementation of the control algorithm is done in MATLAB/Simulink. Matlab is a numerical computing environment and programming language. Maintained by The MathWorks, MATLAB allows easy matrix manipulation, plotting of functions and data, implementation of algorithms, creation of user interfaces, and interfacing with programs in other languages. An additional package, Simulink, adds graphical multidomain simulation and Model-Based Design for dynamic and embedded systems.

Implementation in Matlab raises distinct problems especially in the case of implementation of direct problems, the solution of which in the case of parallel robots leads to nonlinear equation systems.

In the case of NaPaMan this system of equations

(given by (10)) has 18 nonlinear equations with 18 unknowns. For implementation in Simulink, the predefined Matlab function Fsolve will be used. For the implementation in the virtual model, direct kinematic problem will be resolved with the help of the Newton-Raphson method.

Utilizing the implemented model, it will be possible to develop a virtual model, useful in first stages of the theoretical model testing.

Experimental study of the manipulator and the control algorithm is done using a dSpace development board. The main advantage of dSpace is that it is a real-time system. Other advantages consist in the effortless transition from a virtual control system to a physical one. Trouble-free communication with the Matlab/Simulink environment is managed by a Matlab module called Real-Time Workshop, and also an HMI can easily be built up, using ControlDesk, dSpace's HMI development tool.

For experimental determination of positioning and orienting precision a state space control system will be implemented. In this sense a sensorial system that permits the experimental determination of absolute position and orientation of the mobile platform will be developed.

We consider that this type of approach offers more exact data, compared with a control algorithm in joint space, the case in which position sensors offer relative values as information, from every actuator. Based on experimental research, it will be possible to optimize the control algorithm.

## 6. Virtual models and numerical results

Usually a virtual model must be designed in order to ensure a friendly way to cooperate with the customer.

Related to the virtual parallel mechanisms and in order to ensure this property, the virtual model of LMM must include an automatic way to find an initial solution for the nonlinear system of equations. Without losing the generality of the problem, a leg with PUS topology is considered (Fig. 7). An analytical solution of the initial values of the angular parameters of the joints of the leg means that a solution of the inverse geometric model for the initial position must be determined. This solution is also the initial solution for the nonlinear system of equations for the whole mechanism.

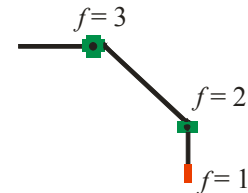

Fig. 7 Virtual model of the PUS loop

Thus, for the leg from Fig. 7, it results

$$\begin{cases} H = A_1, \dots, A_6 \\ A_1^{-1} H = A_2, \dots, A_6 \\ A_2^{-1} A_1^{-1} H = A_3, \dots, A_6 \\ A_3^{-1} A_2^{-1} A_1^{-1} H = A_4, \dots, A_6 \\ A_4^{-1} A_3^{-1} A_2^{-1} A_1^{-1} H = A_5, A_6 \\ A_5^{-1} A_4^{-1} A_3^{-1} A_2^{-1} A_1^{-1} H = A_6 \end{cases} \quad (11)$$

where  $H$  is the absolute transformation matrix, which describes absolute position and orientation of the mobile platform (known for the initial position of the mechanism),  $A_i (i = 1, \dots, 6)$  is the relative transformation matrix. The elements of the  $A_i$  are functions of the joint coordinate ( $q_i$  for the prismatic joint and  $ij$  for all other joints of the leg). Using relations (11) a set of initial values for the parameters which describe the leg from Fig. 7 can be found.

The NaPaMan is composed from a fixed platform and a mobile platform that are connected by independent designed modules. These modules consist of actuators, passive joints and links. According to the number of the independent modules that are used in the constitution of the parallel component of the robot, it can result a variety of different parallel robot topologies.

The main advantages when using a modular design consists of great flexibility, ease of maintenance, short time for construction of a new robot structure with other topology different than the previous one. The modular manner when designing the NaPaMan ensures full reconfigurability and is adopted because of the customers different wishes.

Further, some characteristics of the main components of the NaPaMan are presented. The components that will be described are the ones that will be purchased from specific companies and will be parts of the parallel robot, such as the actuators, the universal joints and the spherical joints.

The actuators used in the constitution of the NaPaMan are the M-235.52S model [7], made by PI, as shown in Fig. 8. The M-235.52S is an ultra-high-resolution linear actuator providing linear motion of up to 50 mm with submicron resolution. It consists of a preloaded ultra-low-friction, heavy-duty ball screw which is driven by a high-power, low-vibration 2-phase stepper motor. The operating voltage is 24 V and the electrical power is 4.75 W. This actuator has a design resolution of 0.156  $\mu\text{m}$  with a minimum incremental motion of 0.1  $\mu\text{m}$ , unidirectional repeatability of 0.2  $\mu\text{m}$  and bidirectional repeatability of 1  $\mu\text{m}$ . It can achieve a maximum speed of 20 mm/s and the maximum travel range is 50 mm. The maximum push/pull force and lateral force is 100 N. It has a weight of 0.8 kg and the operating temperature range is between -20 and +65°C.



Fig. 8 The M-235.52S actuators

The universal joints used in the constitution of the robot are the UJ-HD20 model from Belden universal joints [8]. These joints are manufactured from quality, high-grade alloy steel and can operate at angles up to 45°. The spherical joints chosen to be used when designing the NaPaMan are the TBS6 model produced by THK [9].

The following geometrical dimensions were considered:

- the fixed and the mobile platform have the following geometry ("f" is used when referring to the fixed platform and "m" is used when referring to the mobile platform) (Fig. 9)

$$A_f B_f = C_f D_f = E_f F_f = 266.5 \text{ mm}$$

$$B_f C_f = D_f E_f = A_f F_f = 160 \text{ mm}$$

- the mobile platform has the same geometry with the fixed platform and has the following dimensions

$$A_m B_m = C_m D_m = E_m F_m = 160 \text{ mm}$$

$$B_m C_m = D_m E_m = A_m F_m = 84 \text{ mm}$$

- the distance between the fixed platform and the mobile platform when the actuators are situated at their initial position is 360 mm.

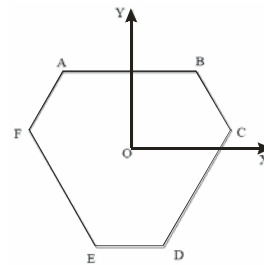

Fig. 9 The geometry of the fixed and mobile platform

Using the properties that were described previously, a CAD model was developed. The components used in the structure of the parallel robot (fixed platform, mobile platform, prismatic joints – actuators, spherical joints, universal joints, links between the joints) were designed and modeled in Solid Works.

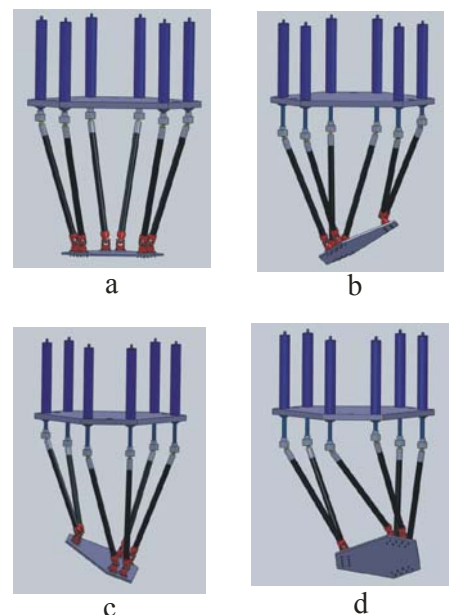

Fig. 10 The NaPaMan with 6 DOF and vertical actuators for different orientations of the mobile platform (NaPaMan 6x PSU)

In order to make difference between the diverse variants, further it will be utilized the following notation: NaPaMan ( $n \times \text{PSU} + k \times \text{PSR}$ ). For example, the variant from Fig. 10 will be notated NaPaMan  $6 \times \text{PSU}$ .

Fig. 10, a, b, c, d presents the variant of NaPaMan  $6 \times \text{PSU}$  with 6 DOF with vertical actuators for different orientations of the mobile platform according to the travel range of the actuators.

In order to demonstrate reconfigurability property of the NaPaMan, Fig. 11 illustrates four variants of parallel robots with vertical actuators (Fig. 10, a – NaPaMan with 6 DOF – NaPaMan  $6 \times \text{PSU}$ , Fig. 10, b – NaPaMan with 5 DOF – NaPaMan  $4 \times \text{PSU} + 1 \times \text{PSR}$ , Fig. 10, c – NaPaMan with 4 DOF – NaPaMan  $2 \times \text{PSU} + 2 \times \text{PSR}$ , Fig. 10, d – NaPaMan with 3 DOF – NaPaMan  $3 \times \text{PSR}$ ). Notations P, S, U and R come from prismatic, spherical, universal and rotational respectively.

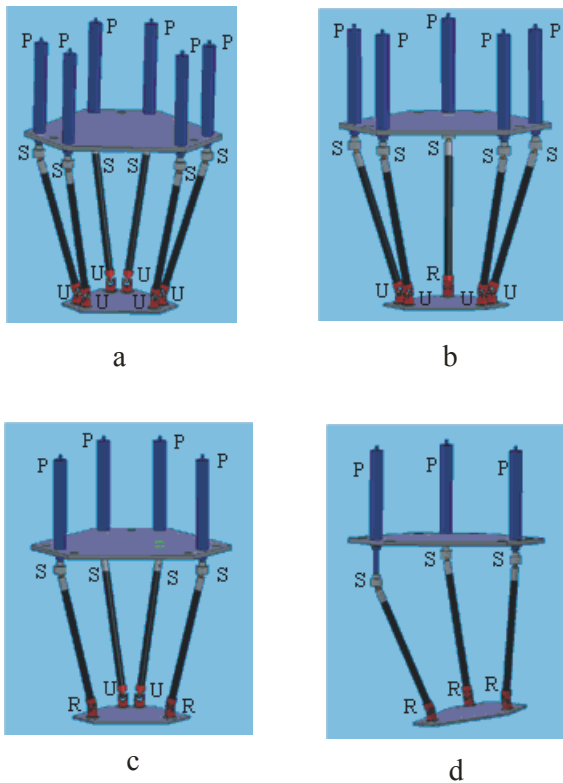

Fig. 11 The NaPaMan with vertical actuators: a – 6 DOF, b – 5 DOF, c – 4 DOF, d – 3 DOF

As we had also mentioned before, NaPaMan is a modular parallel robot. To clearly present this feature of the robot, another variant of NaPaMan was designed, but this time, the order of the joints in the loop is different. Thus, the actuators are mounted between the spherical joints (that are connected to the fixed platform) and the universal / rotational joints (that are connected to the mobile platform). This variant of NaPaMan is the "hexapod type" and it is also respecting the reconfigurability feature. In Fig. 12, four variants of the NaPaMan with the topology described above are presented, (Fig. 12, a – NaPaMan "hexapod type" with 6 DOF – NaPaMan  $6 \times \text{SPU}$ , Fig. 12, b – NaPaMan "hexapod type" with 5 DOF – NaPaMan  $4 \times \text{SPU} + 1 \times \text{SPR}$ , Fig. 12, c – NaPaMan "hexapod type" with 4 DOF – NaPaMan  $2 \times \text{SPU} + 2 \times \text{SPR}$ , Fig. 12, d – NaPaMan "hexapod type" with 3 DOF – NaPaMan  $3 \times \text{SPR}$ ).

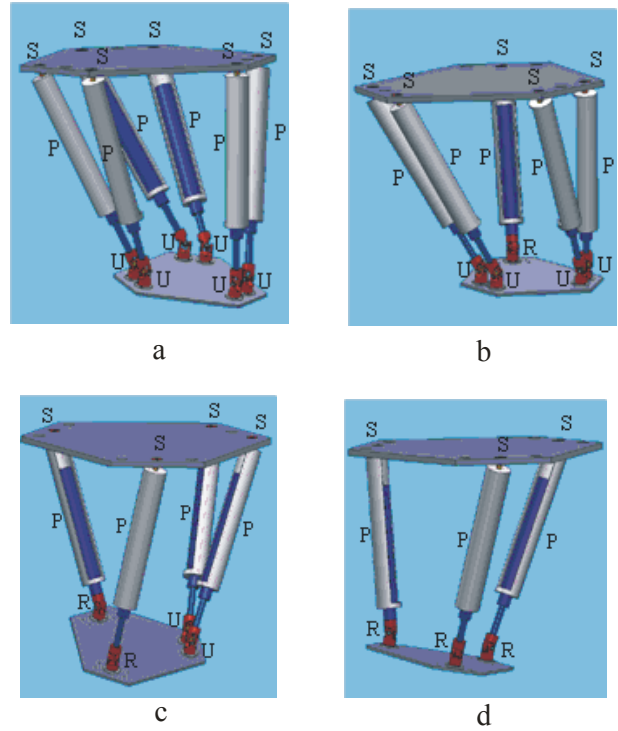

Fig. 12 The NaPaMan "hexapod type": a – 6 DOF, b – 5 DOF, c – 4 DOF, d – 3 DOF

The following numerical results were obtained for the NaPaMan robot variant with vertical fixed actuators. It was also intended the implementation in Matlab of solving the inverse kinematics problem, that will be utilized in the future works to develop control algorithm of the NaPaMan robot.

For solving the inverse kinematics, positions of the motor elements were determined with respect to the end-effector's position.

For the robot with 6 DOF the unknowns are the generalized coordinates  $q_i$ , ( $i = 1, \dots, 6$ ) and  $x_{B_i}, y_{B_i}, z_{B_i}$ , ( $i = 1, \dots, 6$ ) the coordinates of the points  $B_i$ , belonging to the mobile platform of the robot with respect to  $O_{x_0y_0z_0}$  coordinate system, are given (Fig. 13).

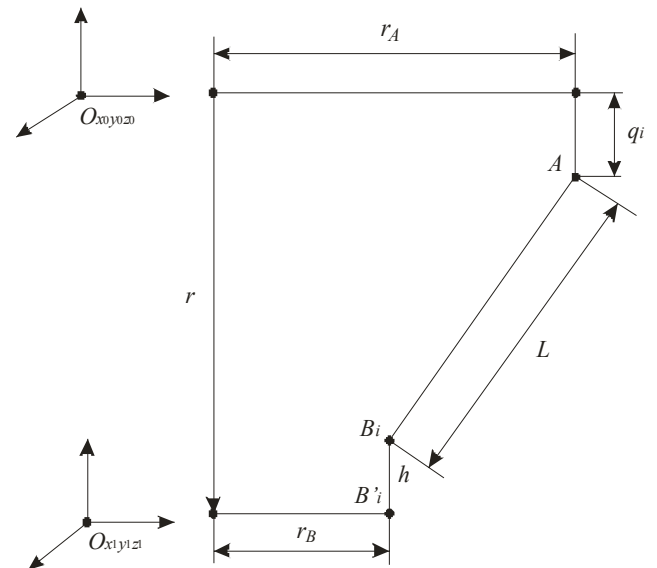

Fig. 13 Kinematical chain of the NaPaMan with 6 DOF and vertical actuators

Fig. 13 presents an arbitrary kinematical chain of the robot with 6 DOF where  $r$  denotes the position vector making the link between  $O_{x_0y_0z_0}$  coordinate system and  $O_{x_1y_1z_1}$  coordinate system,  $h$  denotes the distance between  $B_i$  and  $B'_i$  and  $r_A$  denotes the radius of the circle that defines the fix platform's hexagon of the robot with 6 DOF.

$O_{x_0y_0z_0}$  is the fix coordinate system, attached to the base of the robot with 6 DOF, with the centre in  $O$  and  $O_{x_1y_1z_1}$  is the mobile coordinate system, attached to the mobile platform of the robot with 6 DOF, with the centre in  $O_1$ .

Solution algorithm of inverse kinematics for the NaPaMan with 6 DOF is based on:

- finding  $x_{B'_i}, y_{B'_i}, z_{B'_i}$ , the coordinates of the points

$B'_i$ , belonging to the mobile platform of the robot with respect to  $O_{x_1y_1z_1}$  coordinate system ( $i = 1, \dots, 6$ ), knowing  $r_B$ , the radius of the circle that defines the mobile platform's hexagon of the robot with 6 DOF and the hexagon's angles;

- finding  $x_{B_i}, y_{B_i}, z_{B_i}$  by multiplying the coordinates vectors of the points  $B'_i$  with  $R$ , the transfer matrix from coordinates system  $O_{x_1y_1z_1}$  to  $O_{x_0y_0z_0}$  coordinate system:

$$R = \begin{pmatrix} c\psi c\theta & c\psi s\theta c\phi - s\psi c\phi & c\psi s\theta c\phi + s\psi s\phi & x \\ s\psi c\theta & s\psi s\theta s\phi + c\psi c\phi & s\psi s\theta c\phi - s\psi s\phi & y \\ -s\theta & c\theta s\phi & c\theta c\phi & z \\ 0 & 0 & 0 & 1 \end{pmatrix} \quad (12)$$

where 'c' and 's' denote 'cos' and 'sin' and  $\psi, \theta, \phi$  are Euler's angles.

- finding the  $q_i$  parameters using equation of the sphere

$$q_i = z_{B_i} \pm \sqrt{(L^2 - (x_{B_i} - x_{A_i})^2 - (y_{B_i} - y_{A_i})^2)} \quad (13)$$

where  $x_{A_i}, y_{A_i}, z_{A_i}$  are coordinates of the points  $A_i$ , belonging to the fix platform of the robot with 6 DOF, with respect to  $O_{x_0y_0z_0}$  coordinate system ( $i = 1, \dots, 6$ ) and  $L$  is the length of the segment  $A_iB_i$ .

This algorithm of solving the inverse kinematics was implemented in Matlab/Simulink. In order to get numerical values, a trajectory was assumed and implemented in the solving block. The following values were introduced in the solving block:  $r_A = 185$  mm;  $r_B = 97.30$  mm;  $L = 333$  mm;  $h = 30.5$  mm.

Fig. 14 presents the values of the generalized coordinates,  $q_i$  ( $i = 1, \dots, 6$ ) in a simulation obtained in Matlab/Simulink using the algorithm described above. The mobile platform is performing a movement along  $z$  axis following the position vectors  $r_{initial} = [0, 0, 360, 1]^T$ ,  $r_{final} = [0, 0, 500, 1]^T$ ,  $r = r(t)$  with a linear variation and Euler angles:  $\psi = 0^\circ, \theta = 0^\circ, \phi = 0^\circ$ .

Fig. 15 presents the values of the generalized coordinates,  $q_i$  ( $i = 1, \dots, 6$ ) in a simulation where the mobile platform is performing a movement along  $x$  axis following

the position vectors  $r_{initial} = [0, 0, 360, 1]^T$ ,  $r_{final} = [50, 0, 360, 1]^T$ ,  $r = r(t)$  with a linear variation and Euler angles:  $\psi = 0^\circ, \theta = 0^\circ, \phi = 0^\circ$ .

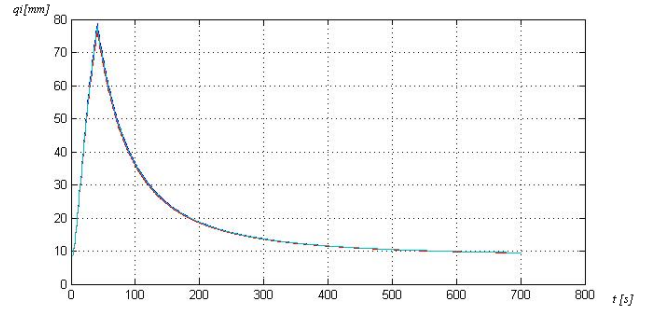

Fig. 14 Actuators displacement when the mobile platform is moving along  $z$  axis

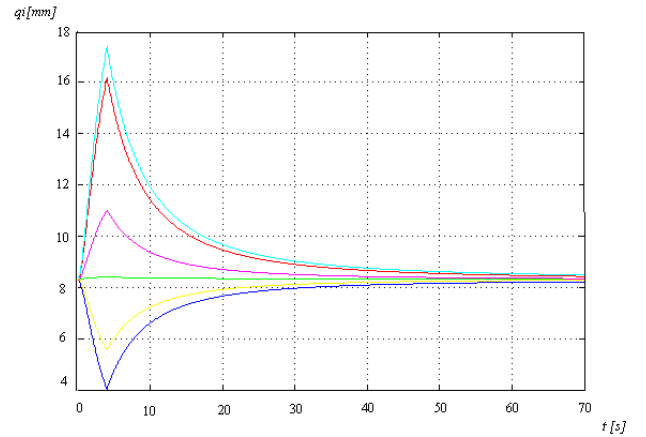

Fig. 15 Actuators displacement when the mobile platform is moving along  $x$  axis

## 7. Conclusions

The hybrid structures can be successfully used for realizing the automated nanomanipulation and nanoassembly.

Utilizing a parallel component, the needed precision can be considerably improved.

The manner of reconfigurable construction of the parallel component is increasing the number of possible applications in which these robots may be used.

The control algorithm can be also developed into modular manner.

## References

1. **Burisch, A., Soetebier, S., Wrege, J., Slatter, R.** Design of a parallel hybrid micro-scarpa robot for high precision assembly. -International IEEE Conference Mechatronics&Robotics, 2004, p.1370-1380.
2. **Hesselbach, J., Raatz, A., Wrege, J., Soetebier, S.** Design and analyses of a macro parallel robot with flexure hinges for micro assembly tasks. -CD Proceedings of 35<sup>th</sup> International Symposium on Robotics (ISR), No. TU 14-041fp, 2004.
3. **Hesselbach, J., Pokar, G., Wrege, J., Heuer, K.** Some aspects on the assembly of active micro systems. -Production Engineering, 2004, v.XI/1, p.159-164.
4. **Brisan, C.** Practical aspects of developing Partner robotic system. -The 3<sup>rd</sup> International Conference on

- Robotics, 2006, p.10-20.
5. **Carretero, J.A.** Kinematic Analysis And Optimization of a New Three-Degree-of-Freedom Spatial Parallel Manipulator.-ASME Journal of Mechanical Design, 2000, v.122, No.1 , p.17-24.
  6. **Hiller, M.** Mechanische Systeme: Eine Einführung in die analytische Mechanik und Systemdynamik. -Berlin, Heidelberg: Springer-Verlag, 1983.
  7. [http://www.physikinstrumente.com/en/pdf/M235\\_Data\\_sheet.pdf](http://www.physikinstrumente.com/en/pdf/M235_Data_sheet.pdf).
  8. [http://www.beldenuniversal.com/pdf/Belden\\_Catalog.pdf](http://www.beldenuniversal.com/pdf/Belden_Catalog.pdf) (p. 16).
  9. <http://www.thk.eu/pdf/BL-300E.pdf> (p. 39).

R. Pacurari, A. Csiszar, C. Brisán

#### KINTAMOS KONFIGŪRACIJOS MODULINIO LYGIAGREČIOJO NANOMANIPULIAORIAUS PAGRINDINĖS PROJEKTAVIMO KRYPTYS

##### R e z i u m ė

Operacijos, atliekamos surenkant vis labiau populiarėjančius miniatiūrinius objektus, didina prietaisų, galinčių mažesniu nei vieno mikrometro tikslumu pozicionuoti ir surinkti mikrodetales, poreikį. Kartu išaugo poreikis projektuoti robotus, kurie gali sėkmingai atlikti šias operacijas. Tokioms operacijoms atlikti rekomenduojama naudoti hibridinės konstrukcijos robotus. Hibridinė konstrukcija sudaryta iš dviejų blokų, kurių pirmasis yra kintamos konfigūracijos blokas, galintis atlikti operacijas mikrometro tikslumu, o antrasis – pjezopavara, galinti atlikti operacijas nanometro tikslumu. Pagrindinis šio straipsnio tikslas – aprašyti hibridinės architektūros robotų, skirtų preciziniam valdymui ir surinkimui, projektavimo principus, ypač daug dėmesio skiriant jo lygiagretiesiems blokams.

R. Pacurari, A. Csiszar, C. Brisán

#### BASIC ASPECTS CONCERNING MODULAR DESIGN OF RECONFIGURABLE PARALLEL MANIPULATORS FOR ASSEMBLY TASKS AT NANOSCALE

##### S u m m a r y

The trend to miniaturization in the field of objects assembly and manipulation is leading to increasing de-

mand for devices that can precisely position and assemble microcomponents with an accuracy of less than one micrometer. Therefore the interest of designing such robots that are able to successfully succeed with these operations is also increasing. For this kind of operations, hybrid structures are recommended. The hybrid structure is composed of two components; the first one is a parallel reconfigurable component which is able to succeed operations with micrometer precision and the second one is a serial component constituted with the use of piezo actuators and is capable to realize operations with nanometer precision. The main interest of this paper is the basic design of a robot with hybrid architecture for precision assembly and manipulation but is focused mainly on its parallel component.

Р. Пацурари, А. Цсисзар, Ц. Брисан

#### ОСНОВНЫЕ АСПЕКТЫ ПРОЕКТИРОВАНИЯ ПЕРЕКОНФИГУРИРУЕМОГО МОДУЛЬНОГО ПАРАЛЛЕЛЬНОГО НАНО МАНИПУЛЯТОРА

##### Р е з ю м е

Тенденция к миниатюризации в области сборки объектов и манипуляции с ними приводит к увеличенному спросу на устройства, которые могут с точностью меньше одного микрометра позиционировать и собрать микрокомпоненты. Поэтому увеличился интерес к проектированию роботов, которые могут успешно справиться с операциями такого рода. Для выполнения такого вида операций рекомендуются гибридные конструкции роботов. Гибридная конструкция робота состоит из двух блоков, первый из которых является блоком с переменной конфигурацией, способный осуществить операции с точностью до одного микрометра, а второй – пьезодвижок, способный осуществить операции с точностью одного нанометра. Цель этой статьи описать основные аспекты проектирования роботов гибридной архитектуры, предназначенных для прецизионной сборки и ее управления. Основное внимание при этом уделено параллельным компонентам.

Received January 29, 2009

Accepted March 27, 2009

DOI: 10.5755/j02.mech.15209