

# Simulation possibilities of controlled rowing force generated by hydraulic loading unit of training facility

V. Grigas\*, A. Legha\*\*, R.T. Tolocka\*\*\*

\*Kaunas University of Technology, Mickeviciaus 37, 44244 Kaunas, Lithuania, E-mail: vytautas.grigas@ktu.lt

\*\*Kaunas University of Technology, Mickeviciaus 37, 44244 Kaunas, Lithuania, E-mail: aleksandra.legha@ktu.lt

\*\*\*Kaunas University of Technology, Mickeviciaus 37, 44244 Kaunas, Lithuania, E-mail: tadas.tolocka@ktu.lt

## 1. Introduction

Nowadays a lot of investigations are devoted to the analysis of a various kind of a biomechanical systems [1, 2, 3]. Indoor rowing machines are widely used for training amateurs and professionals of all kinds, not only rowers, because they give general body loading, and allow to train indoors. In case the machines are meant specifically for training rowers, it is very important to design them making the loading as close to real conditions of rowing as possible. This depends more or less on successful design of the loading unit. The analysis of the existing designs [4] shows that although loading of the rower is analyzed comprehensively [5-7], none of them [8] allows to simulate the real loading on the oar sufficiently.

Basing on the prototype exploited in Kaunas Academy of Physical education, the authors are working on the rowing machine which is able to simulate the loading on the oar quite adequately [9, 10]. Its rotational hydraulic loading unit (Fig. 1) consists of two chambers, divided by two plates: immobile and movable, which is connected to the oar. The moving plate is equipped with the channel or channels of changeable diameter for work liquid access from one chamber into another. The oar loading is achieved due to the working liquid pressure on the moving plate, arising when the plate moves together with the oar during exercising. Its control is realized by changing diameter of the channels. Development of such rowing machine requires to define the law of change of the channel diameter, based on the known law of oar loading during the rowing stroke.

The primary problem of the ongoing development of the rowing machine loading unit is to establish what geometric parameters of the unit allow to achieve the re-

quired values of loading on the oar at different intensity of rowing. The paper presents the results of computer aided analysis of the possibilities to put the chosen method of loading into practice, and to develop the loading unit.

## 2. Hydrodynamic analysis of loading unit

The rowing force and parameters of real academic rowing cycle have been measured experimentally [10]. It was defined that the rowing cycle lasts 1 - 1.5 s, the oar handle linear velocity is 0.5 - 2 m/s and the sportsman is able to develop the rowing force up to 2000 N. It allowed us to calculate the maximum values of the necessary velocity of the moving plate and the force on it as 0.2 m/s and 20000 N, respectively.

The hydrodynamic analysis of the loading unit was carried out in order to define the channel diameter in the moving plate of the loading unit to achieve the determined load and to vary it in the necessary range. In order to determine the influence of the working liquid viscosity on the loading, calculations were carried out with water and industrial oil I-40 A as working liquid (finite element method was used in both cases). The main parameters of the work liquids are given in Table 1.

Table 1

Working fluid parameters

Parameter	Water	Oil I - 40 A
Kinematical viscosity, mm <sup>2</sup> /s	1.79	35-45
Dynamic viscosity, Pa·s	1.79·10 <sup>-3</sup>	(51-75)·10 <sup>-3</sup>
Density, kg/m <sup>3</sup>	1000	900

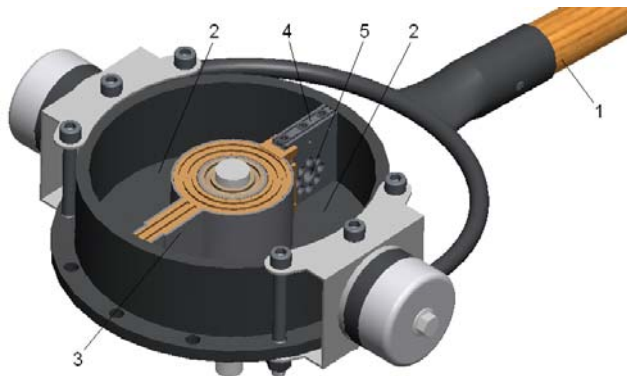

Fig. 1 Loading unit of the rowing machine: 1 - oar handle; 2 - chambers; 3 - immobile plate; 4 - moving plate (diaphragm); 5 - channel

The simplified parametrical geometric model of a hydraulic loading unit was developed by geometrical modeling software SolidWorks. The working volume of the loading unit was simplified assuming it as a parallelepiped with a cross-section corresponding the size of moving plate in hydraulic loading unit (55x60 mm), and consisting of two 100 mm length chambers, separated by the diaphragm having a changeable diameter circular channel (from 3 to 12 mm). The computational model was prepared and computations of the working liquid pressure acting upon the plate were completed by using COSMOSFlowworks software. The inverse model was used assuming that the liquid flows through plate which is unmovable. The total hydrodynamic force acting the plate was obtained by integrating the pressure of liquid.

The internal volume of the model was meshed by 3 mm size finite elements mesh, refined to 0.5 mm near the diaphragm and in the channel. The geometrical and computational finite element models are shown in Fig. 2. The boundary conditions were defined by describing the inlet velocity on the rectangular area of one end geometrical model and the outlet pressure (equal to environmental, i.e. atmospherical, 101325 Pa) on the internal rectangular area at the opposite end of model, thus simulating the movement of the diaphragm with an appropriate velocity in the channel, filled with the working liquid.

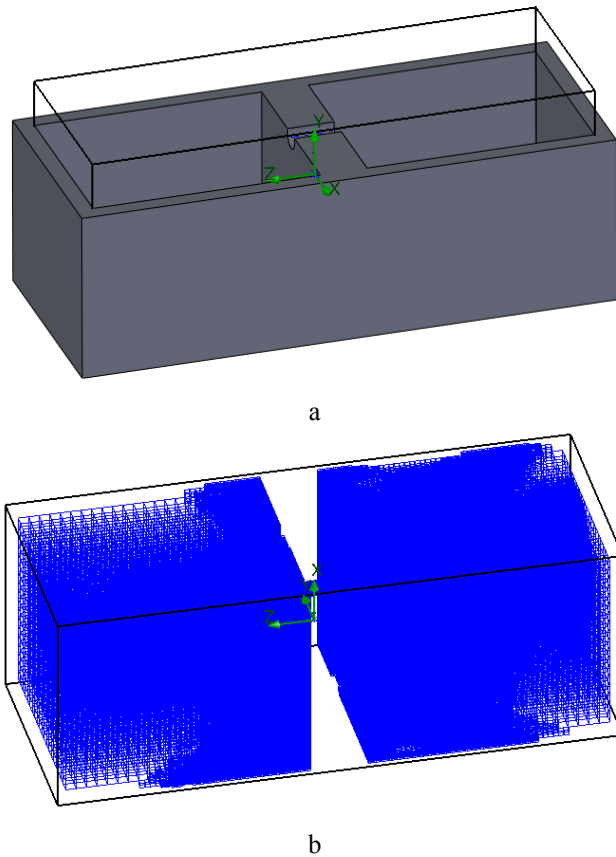

Fig. 2 Geometrical (a) and computational finite element (b) models for loading unit hydrodynamic analysis

The internal flow analysis was carried out and computations fulfilled at the following parameters:

- working liquid flow velocity range 0.05 - 0.25 m/s with 0.05 m/s step;
- primary temperature 20°C;
- channel wall roughness 0.05 mm;
- channel diameter variation range 3 - 12 mm.

Pressure on the moving plate of the loading unit, total velocity of the working liquid and its components and flow trajectories were obtained at different channel diameters and flow velocities for two working liquids. Some results corresponding to the channel diameter 6 mm and water flow velocity 0.25 m/s are presented in Figs. 3 and 4.

The results of great practical importance are the relationships (Figs. 5 and 6) between the channel diameter and the achieved loading force.

The investigation showed that viscosity of the working liquid is the factor having small effect on the value of the generated loading force. For example, at the channel cross-section area 28.27 mm<sup>2</sup> and flow velocity

0.25 m/s, the force achieved using oil I-40 A and water force differs only 10% approximately, while dynamic viscosity differs 75 times.

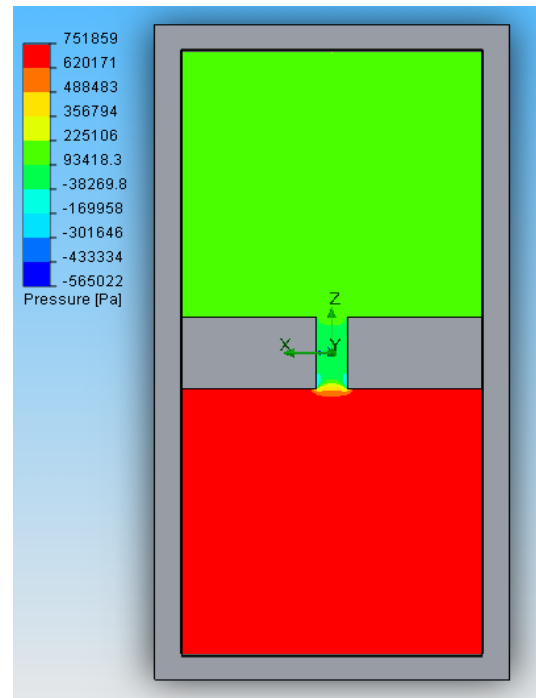

Fig. 3 Distribution of the water pressure in the loading unit

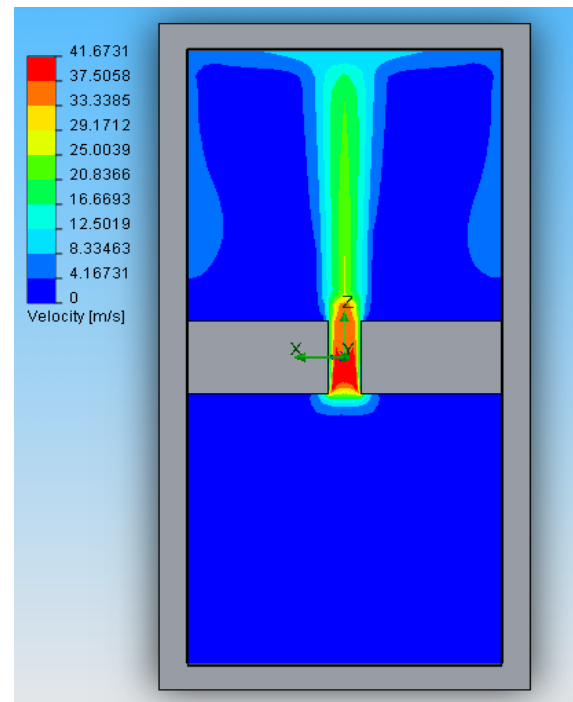

Fig. 4 Total velocity distribution of the working liquid (water) flow

By changing the channel cross-section area in the range of 8.04 - 113.1 mm<sup>2</sup> (what corresponds to the channel diameter variation range 3 - 12 mm) and the working liquid flow velocity in the range 0.05 - 0.25 m/s, the loading force on the working plate of the loading unit was varying in the range 6.7008 - 31187 N, which exceeds the necessary maximal force.

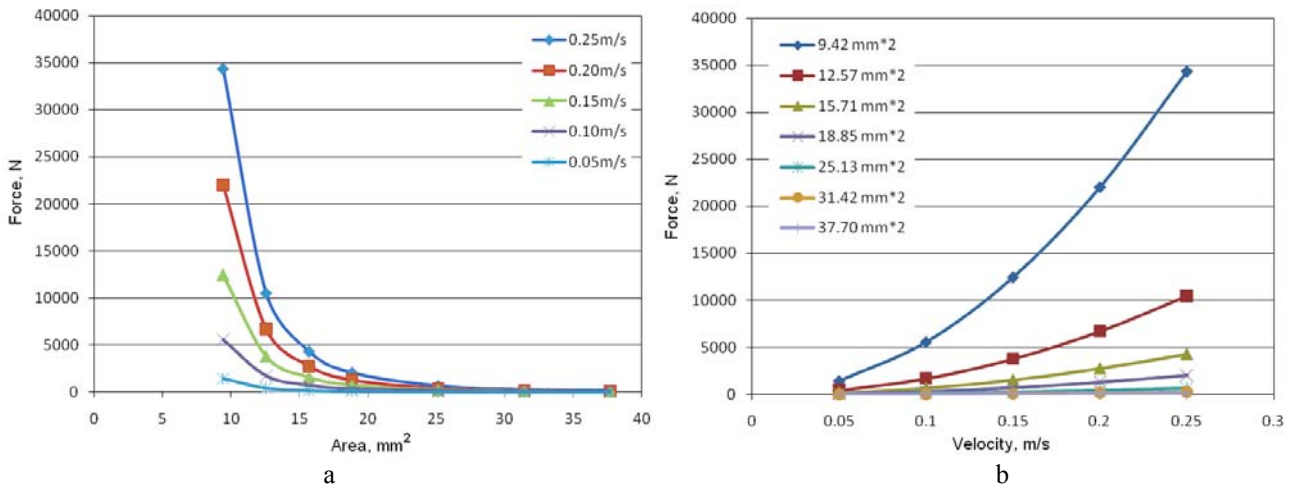

Fig. 5 Relationships load force vs. channel cross-section area (a) and load force vs. flow velocity (b) for water as working liquid

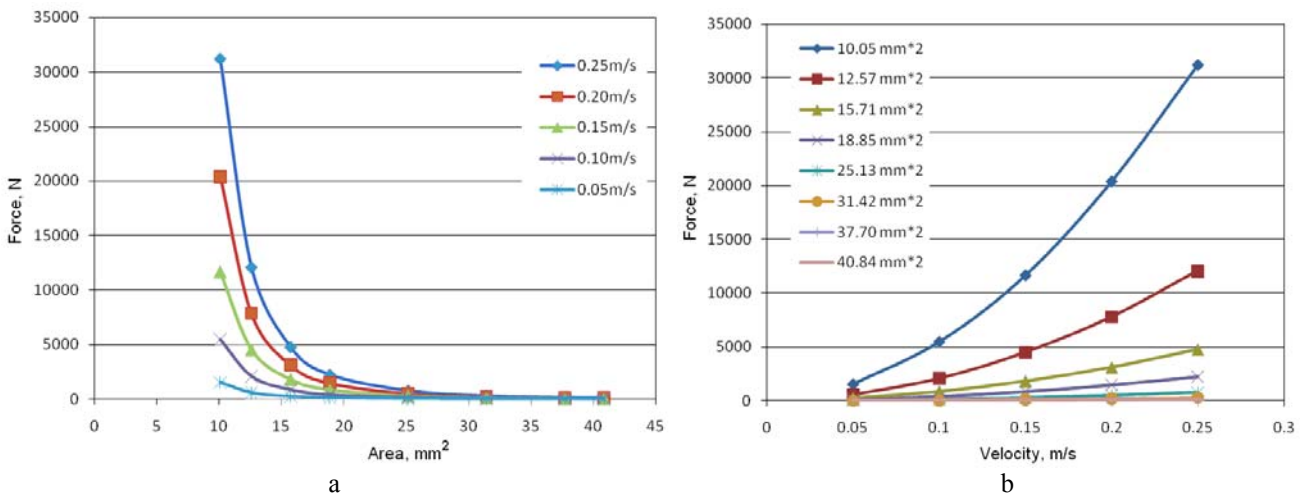

Fig. 6 Relationships load force vs. channel cross section area (a) and load force vs. flow velocity (b) for oil I-40A as working liquid

### 3. Loading control by computerized hydraulic system

Control of oar load during the rowing cycle is complicated enough – it is necessary to simulate the real law of its change and synchronize the load on both oars. The computerized hydraulic system is proposed for it, the principal scheme of which is given in Fig. 7.

The system is measuring angular position and angular velocity of the oar and controlling channel diameter of loading unit corresponding to it. It can be easily expanded to accumulate and store the information on the parameters of exercising. The channel diameter control may be performed by using a proportional flow valve. The main factors for its selection are the flow yield and fast enough response. In accordance with this, it was defined that Rexroth Bosch Group valve FRE 6 B -2X/25QK4RV with maximum flow rate 25 L/min is suitable in this case.

The ongoing investigation is foreseen to define the law of flow channel diameter control to make the rower loading as close as possible to natural and to carry out experimental investigation of the training facility equipped with the controlled loading unit.

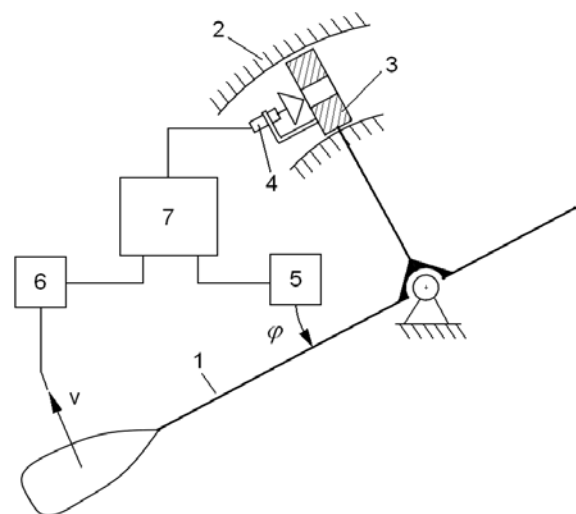

Fig. 7 Computerized system of the loading unit control: 1 - oar; 2 - hydraulic loading unit; 3 - moving plate; 4 - proportional flow control valve; 5, 6 - oar angular position and velocity sensors; 7 - controller

#### 4. Conclusions

The oar loading simulating the natural one may be achieved by a hydraulic unit of rowing training facility. The loading unit has been proposed, in which force value during the rowing stroke is regulated by the control of the working liquid flow channel diameter by using a computerized system equipped with the oar angular position and velocity sensors and proportional flow valve.

Loading on the oar generated by the unit has been investigated by finite element analysis using CosmosFloWorks software and it has been stated that such a unit is able to generate the loading force on the oar in the range of practical values. The range of channel diameter variation at different flow velocities of working liquid (which corresponds to the different velocity of the ship) was determined. It was defined that working liquid viscosity at practical regimes is not much influencing the load force.

The obtained results are primary for ongoing development of the loading unit, and the law of channel diameter variation for natural load on the oar simulation will be defined in the next investigation.

#### References

1. **O'Toole, K.T., McGrath, M.M., Hatchett, D.W.** Transient characterisation and analysis of shape memory alloy wire bundles for the actuation of finger joints in prosthesis design. -Mechanika. -Kaunas: Technologija, 2007, Nr.6(68), p.65-69.
2. **Rukiža, E., Eidukynas, V., Dulevičius, J.** The influence of seat pad stiffness and damping on the intervertebral forces in the junction of thoracic and lumbar spinal curves. -Mechanika. -Kaunas: Technologija, 2008, Nr.6(74), p.52-55.
3. **Grigas, V., Domeika, A., Legha, A., Satkunskienė, D., Toločka, R.T.** Rowing force and its simulation on training facility. -Solid State Phenomena: Mechatronics Systems and Materials III. Uetikon-Zuerich: Trans Tech Publications Ltd, 2009, v.147-149, p.712-715.
4. **Muckus, K., Kriščiukaitis, A., Legha, A., Toločka, R.T.** Indoor rowing machine with training data analysis system. -Journal of Vibroengineering, 2007, v.9, No.3, p.69-73.
5. **Van Holst, M.** Simulation of Rowing, <http://home.hccnet.nl/m.holst/report.html> (2004).
6. **Baca, A., Kornfeind, P., Heller, M.** Feedback systems in Rowing. The Engineering of Sport 6. 2006, v.1: developments for Sports. Ed. :E. F. Moritz and S. Haake. Springer Science+Business Media, LLC, p.407-412.
7. **Zatsiorsky, V.M.** Science and Practice of Strength Training. -Human Kinetics, 1995.-243p.
8. **Legha, A., Muckus, K., Toločka, R.T.** Development of indoor rowing machine. -Vibroengineering 2006: proceedings of the 6th International Conference, October 12 - 14, 2006, Kaunas, Lithuania, 2006, p.81-83.
9. **Domeika, A., Grigas, V., Toločka, R.T.; Žiliukas, P.** Developing academic rowing simulators. -Transport Means - 2008: proceedings of the 12th international conference, October 23-24, 2008, Kaunas, Lithuania, 2008, p.114 -117.
10. **Grigas, V., Domeika, A., Legha, A., Satkunskienė, D., Toločka, R.T.** Rowing force and its simulation on training facility. -MSM 2008: 4th International Conference, Mechatronic Systems and Materials, Bialystok, Poland, July, 14 -17, 2008, p.228-229.

V. Grigas, A. Legha, R. T. Toločka

REALIOS APKROVOS IRKLAVIMO TRENIRUOKLIO HIDRAULINIŲ MECHANIZMU IMITAVIMO GALIMYBĖS

Re z i u m ė

Atlikti originalaus irklavimo treniruoklio apkrovos mazgo, kuriuo galima imituoti realią ciklo metu irklą veikiančią apkrovą, tyrimai. Naudojant SolidWorks ir CosmosFloWorks programinę įrangą sumodeliuota apkrovos mazgo darbinė aplinka ir apskaičiuotos mazgo išvystomos apkrovos priklausomybės nuo jo geometrinių parametrų ir apkrovimo greičio.

V. Grigas, A. Legha, R. T. Toločka

CONTROLLED ROWING FORCE SIMULATION POSSIBILITIES BY HYDRAULIC LOADING UNIT OF TRAINING FACILITY

S u m m a r y

Investigation of a novel loading unit in rowing training facility which simulates real load on the oar during the rowing stroke, has been carried out. The work environment has been simulated by software SolidWorks and CosmosFloWorks. The load force and unit geometry, and loading velocity relationships have been defined.

В. Григас, А. Легха, Р. Т. Толочка

ИССЛЕДОВАНИЕ ВОЗМОЖНОСТЕЙ ИМИТИРОВАНИЯ РЕАЛЬНОЙ НАГРУЗКИ ГИДРАВЛИЧЕСКИМ НАГРУЗОЧНЫМ УЗЛОМ ГРЕБНОГО ТРЕНИРОВОЧНОГО УСТРОЙСТВА

Р е з ю м е

Проведено исследование оригинального гидравлического нагрузочного узла гребного тренировочного устройства, позволяющего имитировать реальную нагрузку на весло во время гребка. Смоделировано рабочее пространство узла нагрузки и определены зависимости усилия нагрузки от геометрических параметров узла и скорости нагружения.

Received December 11, 2008

Accepted March 05, 2009