

Investigation of compression of cylindrical packages

E. Kibirškis*, V. Bivainis**, L. Ragulskis***, A. Dabkevičius****

*Kaunas University of Technology, Studentų 56, 51424 Kaunas, Lithuania, E-mail: edmundas.kibirsktis@ktu.lt

**Kaunas University of Technology, Studentų 56, 51424 Kaunas, Lithuania, E-mail: vaidas.bivainis@ktu.lt

***Vytautas Magnus University, Vileikos 8, 44404 Kaunas, Lithuania, E-mail: l.ragulskis@if.vdu.lt

****Kaunas University of Technology, Studentų 56, 51424 Kaunas, Lithuania, E-mail: arturas.dabkevicius@ktu.lt

1. Introduction

In this paper some of the more important results investigating the possibilities of improving the ecological level of packages, which were obtained while performing the joint Lithuanian–Ukrainian research project [1], are analyzed. One of the main requirements is to produce packages in such a way that their volume and weight would be small while at the same time the strength parameters of the package would remain sufficient. In this paper the influence of the package shape on mechanical characteristics in the process of its compression is investigated.

In the process of analyzing the research papers of similar character one can note that the research papers [2-4] where the results of experimental and numerical investigation of cardboard packages of rectangular shape are presented. In the paper [5] the relationship between the deformations of plastic packages of cut conical shape under axial load is investigated. Experimental and theoretical investigations of static axial compression of circular plastic PVC pipes and two-layer hollow bars are presented in the research papers [6, 7]. The behaviour of deformation of their shape is being very similar to the deformation of the surface of cardboard packages of cylindrical shape. In the paper [8] the behaviour of cardboard as of an anisotropic material under the action of loading is analyzed, and the investigation is performed by using the finite element method. Similar investigations of elements buckling are presented in the paper [9].

However, the research papers investigating resistance to compression of the paper/paperboard packages of cylindrical shape were not found. Thus the purpose of this paper is to perform numerical and experimental investigations of cylindrical packages by determining the peculiarities of deformation of the cylinder surface.

The analysis of stability of cylindrical packages using three dimensional elements is based on the relationships described in [10, 11]. The analysis of stability of a shell type structure using a three dimensional element consists of two stages. Static problem by assuming the displacements at the lower and upper edges of the analyzed structure to be given is solved. Stability of the structure because of the additional stiffness due to the static compression determined in the previous stage of analysis is investigated. The model for the analysis of axial loading of a package is based on the analysis of an axi-symmetric elastic structure. Geometric nonlinearity is taken into account by the method of initial strains [10-12]. The force is increased by small steps and thus graphical relationship of displacement-force is calculated.

2. Model for the analysis of the shell type structure stability

The nodal coordinates of a three dimensional element are obtained from the nodal coordinates of a two dimensional element. So a node of a two dimensional element corresponds to three nodes of a three dimensional element: on the lower surface, on the middle surface (coinciding with the node of the two dimensional element) and on the upper surface.

First, the static problem is analyzed. It is assumed that the displacements on the lower and upper boundary of the analyzed structure are given and they produce the loading vector. Thus the vector of displacements is determined by solving the system of linear algebraic equations. In the second stage of the analysis, the eigenproblem of stability of the structure with additional stiffness due to the static compression is solved.

Further x , y and z denote the axes of the system of coordinates. In order to obtain the coordinates of the nodes on the lower surface of the shell and on the upper surface of the shell for each node of the two dimensional element, the derivatives of x , y and z with respect to the local coordinates ζ and η are calculated as

$$\begin{bmatrix} \frac{\partial N_1}{\partial \xi} & \frac{\partial N_2}{\partial \xi} & \dots \\ \frac{\partial N_1}{\partial \eta} & \frac{\partial N_2}{\partial \eta} & \dots \end{bmatrix} \begin{bmatrix} x_1 & y_1 & z_1 \\ x_2 & y_2 & z_2 \\ \vdots & \vdots & \vdots \end{bmatrix} = \begin{bmatrix} \frac{\partial x}{\partial \xi} & \frac{\partial y}{\partial \xi} & \frac{\partial z}{\partial \xi} \\ \frac{\partial x}{\partial \eta} & \frac{\partial y}{\partial \eta} & \frac{\partial z}{\partial \eta} \end{bmatrix} \quad (1)$$

where N are the shape functions of the analyzed two dimensional finite element, x_i , y_i , z_i are the nodal coordinates of the finite element.

The vector $\begin{Bmatrix} n_x \\ n_y \\ n_z \end{Bmatrix}$ is the unit vector in the direction

of vector product of $\begin{Bmatrix} \frac{\partial x}{\partial \xi} \\ \frac{\partial y}{\partial \xi} \\ \frac{\partial z}{\partial \xi} \end{Bmatrix}$ and $\begin{Bmatrix} \frac{\partial x}{\partial \eta} \\ \frac{\partial y}{\partial \eta} \\ \frac{\partial z}{\partial \eta} \end{Bmatrix}$.

So the coordinates of the node on the lower surface of the shell are $\begin{Bmatrix} x_i \\ y_i \\ z_i \end{Bmatrix} - \begin{Bmatrix} n_x \\ n_y \\ n_z \end{Bmatrix} \frac{h}{2}$, where h denotes thickness of the shell.

The coordinates of the node on the upper surface

of the shell are $\begin{Bmatrix} x_i \\ y_i \\ z_i \end{Bmatrix} + \begin{Bmatrix} n_x \\ n_y \\ n_z \end{Bmatrix} \frac{h}{2}$.

3. Model for the analysis of axial loading of the packages

Further x denotes radial coordinate and y denotes axial coordinate of the cylindrical system of coordinates. The element has two nodal degrees of freedom: the displacements u and v in the directions of the axes x and y .

The vector of displacements $\{\delta\}$ is determined by solving the system of linear algebraic equations. The force is increased by small steps.

The following derivatives are calculated

$$\begin{Bmatrix} \frac{\partial u}{\partial x} \\ \frac{\partial v}{\partial x} \\ \frac{\partial u}{\partial y} \\ \frac{\partial v}{\partial y} \\ \frac{u}{x} \end{Bmatrix} = [G]\{\delta\} \quad (2)$$

where

$$[G] = \begin{bmatrix} \frac{\partial N_1}{\partial x} & 0 & \dots \\ 0 & \frac{\partial N_1}{\partial x} & \dots \\ \frac{\partial N_1}{\partial y} & 0 & \dots \\ 0 & \frac{\partial N_1}{\partial y} & \dots \\ \frac{N_1}{x} & 0 & \dots \end{bmatrix} \quad (3)$$

where N_i are the shape functions of the finite element.

Then the following matrix is introduced

$$[A] = \begin{bmatrix} \frac{\partial u}{\partial x} & \frac{\partial v}{\partial x} & 0 & 0 & 0 \\ 0 & 0 & \frac{\partial u}{\partial y} & \frac{\partial v}{\partial y} & 0 \\ 0 & 0 & 0 & 0 & \frac{u}{x} \\ \frac{\partial u}{\partial y} & \frac{\partial v}{\partial y} & \frac{\partial u}{\partial x} & \frac{\partial v}{\partial x} & 0 \end{bmatrix} \quad (4)$$

So the geometric nonlinearity can be taken into account by the method of initial strains

$$\{\varepsilon_0\} = -\frac{1}{2}[A][G]\{\delta\} \quad (5)$$

This produces the load vector

$$\{F\} = \int [B]^T [D] \{\varepsilon_0\} 2\pi x dx dy \quad (6)$$

where the matrix $[B]$ is defined from

$$\begin{Bmatrix} \frac{\partial u}{\partial x} \\ \frac{\partial v}{\partial y} \\ \frac{u}{x} \\ \frac{\partial u}{\partial y} + \frac{\partial v}{\partial x} \end{Bmatrix} = [B]\{\delta\} \quad (7)$$

and $[D]$ is the matrix of elastic constants.

4. Results of analysis of the shell type structure stability

A cylindrical structure is analyzed. For the static problem the following boundary conditions are assumed: on the lower boundary all the displacements are equal to 0. On the upper boundary all the displacements are equal to 0 except the displacement in the direction of the z axis which is equal to 1. For the eigenproblem on the lower and the upper boundaries all the displacements are assumed equal to zero.

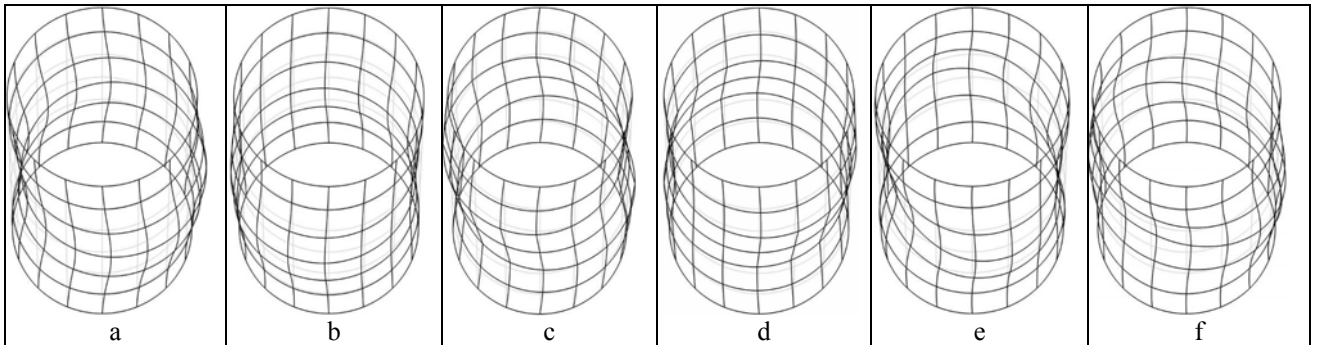

Fig. 1 The six eigenmodes of buckling analysis: a – the first stability eigenmode, b – the second stability eigenmode, c – the third stability eigenmode, d – the fourth stability eigenmode, e – the fifth stability eigenmode, f – the sixth stability eigenmode

Dimensions of the package and mechanical characteristics of the cardboard “*Galerie Card 280*” are presented in Table. Calculations were performed using isotropic model by assuming the physical parameters equal to the averaged values of the corresponding parameters of the orthotropic model.

The first eigenmode of stability is presented in Fig. 1, a, the second – in Fig. 1, b, the sixth – in Fig. 1, f.

The first and the second, the third and the fourth, the fifth and the sixth eigenmodes correspond to the same eigenvalue respectively.

A thin rectangular structure parallel to the axial coordinate is analyzed. On the lower boundary all the displacements are assumed equal to zero. The node at the center of the upper boundary is loaded by a force in the direction of the axial coordinate, the value of the force is negative (it is acting in opposite direction than the y axis).

Graphical relationship from numerical investigations of package walls elements deformation under axial compression is obtained and presented in Fig. 2. The force is represented in the vertical direction, while the displacement of the same degree of freedom is represented in the horizontal direction.

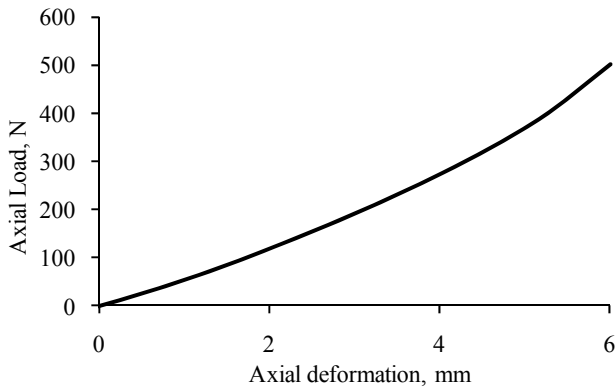

Fig. 2 The displacement–force graphical relationship

5. Method of experimental investigations

In order to perform the experimental tests, cardboard packages of cylindrical and square geometrical shape were produced. For production of the cylindrical packages, two types of cardboard were used; they were chosen on the basis of the recommendations provided by the producer and they are most suitable for the production of packages of the investigated size.

Continuing the research of work [2], cardboard package with the walls of the same height and same area of lateral walls were produced for the experiment. The main characteristics of the samples and of the types of used cardboards are presented in the Table.

The setup used for experimental investigations was of the same type as described in the research paper [4].

Empty (not filled) packages were investigated under the action of static axial load. The direction of cardboard of the side walls of the packages coincided with the direction of compression. During the experimental investigation the highest value of the axial compression, at which the structure of the package loses stability and starts to buckle, was registered. The diagram of the experimental setup is presented in Fig. 3.

From the estimates of the values of the axial compression force obtained in the course of experimental investigations, the maximum value, at which the cylindrical cardboard package loses stability and starts to buckle, is determined. The relationships of package deformation due to axial load are presented graphically in Fig. 4, when the package deforms by the interval of 1 mm. The packages were deformed up to 20 mm. In order to compare the behaviour of the geometrical shape of the experimental samples during the process of compression, the sample was photographed by the digital camera with a fixed interval of photographing.

The tests were carried out at the ambient temperature of $20\pm 2^\circ\text{C}$ and air humidity $65\pm 2\%$.

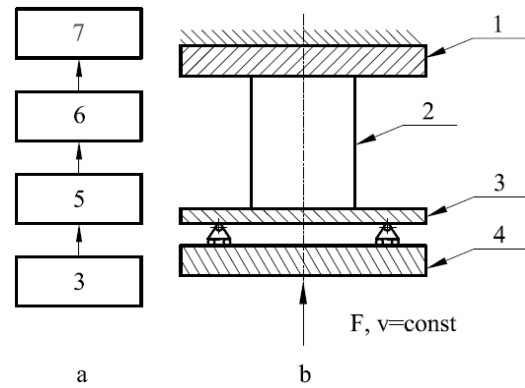

Fig. 3 Structural scheme of measuring equipment (a) and simplified scheme of package compression (b): 1 – immovable support; 2 – package under compression, 3 – supporting plate with tensometrical converters; 4 – moving lower background support; 5 – tensometric amplifier TS-3; 6 – oscilloscope PicoScope 3424; 7 – personal computer

6. Results of experimental investigations and their analysis

The obtained relationship of the deformation of samples of packages of cylindrical and rectangular shape from axial load F is presented in Fig. 4.

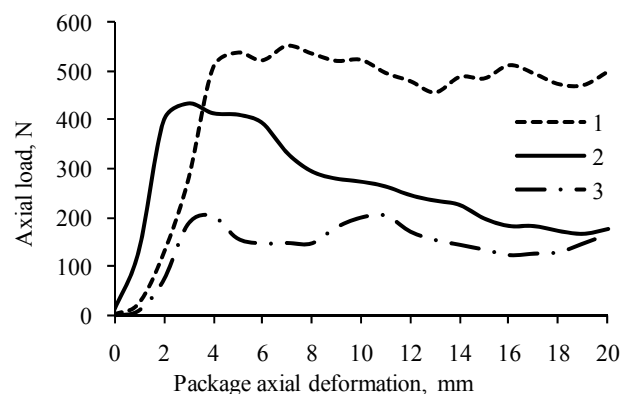
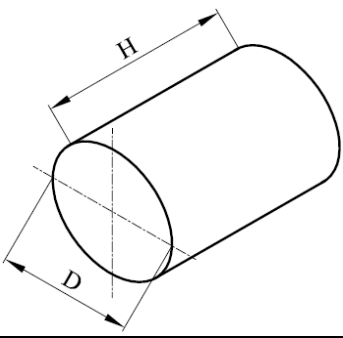
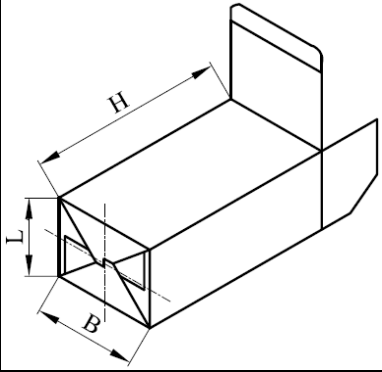

Fig. 4 Relationship of the deformation of the package due to vertical axial load: 1 – packages made of “*Galerie Card 280*”; 2 – packages made of „*Alaska 275*“. Curves 1 - 2 – packages of cylindrical shape, 3 – packages of rectangular shape made of the cardboard “*Galerie Card 280*”

Technical characteristics of experimental samples and experimental results

Geometrical shape of the package:			
Material of the package:	Cardboard of the GC-2 type "Alaska 275"	Cardboard of the FBB type "Galerie Card 280"	Cardboard of the FBB type "Galerie Card 280"
Number of samples, units:	10	10	10
Surface weight of cardboard, g/m ² :	275	280	280
Thickness of cardboard, mm:	0.456	0.450	0.450
Poisson's ratio of cardboard, ν :	0.3	0.3	0.3
Stiffness of cardboard in the MD/CD directions according to the method of "Tabber 15 ^{0c} ", mNm:	21.7/10.4	24.0/11.6	24.0/11.6
Dimensions of packages (arithmetic mean of the values is presented), mm:	$H=138.9$ $D=72.6$	$H=138.8$ $D=72.7$	$H=138.6$ $L, B=57.6$
Perimeter of package base, mm:	228.1	228.4	230.4
Area of package base, mm ² :	4139.6	4151.1	3317.8
Axial moment of inertia, mm ⁴ :	6.9×10^4	6.8×10^4	5.7×10^4
Radius of inertia, mm:	25.7	25.7	23.5
Highest axial load value at which package deformations start, N:	433	554	205
Axial load value per length of perimeter, N/mm:	1.9	2.4	0.9
Axial load value per unit of base area, N/mm ² :	0.10	0.13	0.06
Axial load value per unit of moment of inertia, N/mm ⁴ :	6.3×10^{-3}	8.2×10^{-3}	3.6×10^{-3}
Axial load value per unit of radius of inertia, N/mm:	16.9	21.6	8.7

Packages of cylindrical shape made of the cardboard "Galerie Card 280" start to buckle under the vertical axial load at about 554 N, while packages made of the cardboard "Alaska 275" start to buckle under the axial compression of about 433 N. The latter package starts to buckle under the axial compression force which is about 22% lower. Packages of rectangular shape produced from the cardboard "Galerie Card 280" lose stability under the action of the axial load at about 205 N. As it is seen from the results of experimental investigations, the shape of the package has substantial influence on the allowable vertical axi-symmetric compression load. Under axial load per perimeter, area, moment of inertia and radius of inertia units, the package of cylindrical shape resists the axial load, which is about 2.4 times higher when compared with the package of rectangular type (see Fig. 4, curves 1 and 3, Table 1).

The character of variation of the compression force in the region of elastic zone is almost linear.

In Fig. 5 the photos of the compression process of the cylindrical package are presented, which show the be-

haviour of the package during its deformation, and in Fig. 5, e the photo of the deformed rectangular package is presented.

When analyzing the obtained results of numerical and experimental investigation (Figs. 2 and 4), it is possible to make a conclusion that the deformation of the material of the package in the region of elastic zone is described by the numerical model with acceptable precision. However, the model does not take into account plastic deformations and thus is not applicable in the region of plastic deformations. In the investigations of packages the zone of plastic deformations is of secondary importance because the package with plastic irreversible deformations is unsuitable for use.

By comparing the image of the outer walls of the cylindrical and rectangular packages deformed during the process of axial compression, one can note that the character of deformation in the vertical direction of the packages presented in Fig. 5, d and in Fig. 5, e is different.

By comparing the obtained results of numerical (Fig. 1) and experimental (Fig. 5, a-d) investigations of the

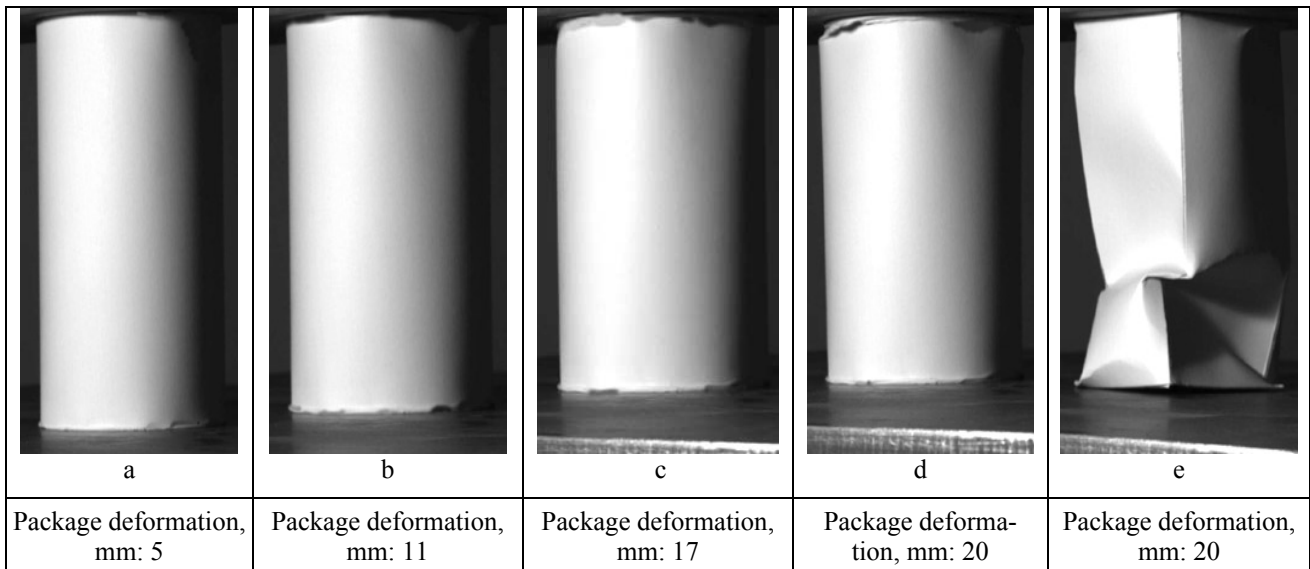

Fig. 5 Photos of the deformation process of the package when the value of deformation is presented, mm: *a–d*: deformation of the cylindrical package, *e*–deformation of the rectangular package. Material of the cylindrical and rectangular packages–cardboard “Galerie Card 280”

cylindrical package, one can see that the numerical model describing the axial compression of the cylindrical package should be improved because the photos of deformation of the walls obtained during the experimental investigations (Fig. 5, a-d) indicate the development of deformations in the upper and lower parts of the package.

7. Conclusions

Results of the experimental investigations indicated that the shape of the package has substantial influence on the allowable vertical axial load. The package of cylindrical shape under axial load per perimeter, area, moment of inertia and radius of inertia units resists the axial load, which is about 2.4 times higher when compared with the package of rectangular type of the similar mass and the same base perimeter and height.

It is determined that the character of surface deformation of the packages of cylindrical shape under the action of vertical axial load is essentially different from the image of the deformation of the walls of the packages of rectangular type.

As indicated by the results of experimental investigations, the presented numerical model of the investigation of cylindrical package does not fully describe the process of deformation under axial compression in the vertical direction. Thus more complicated models might be applied for the solution of this problem.

The problem for the analysis of package stability as of a cylindrical shell type structure is solved using three dimensional elements. The nodal coordinates of the three dimensional elements are obtained from the two dimensional ones which represent the middle surface of the shell.

The static problem by assuming the displacements at the edges of the analyzed structure to be given is solved. Then the stability of the investigated structure because of the additional stiffness due to the static compression determined previously is analyzed.

The axial loading of an axi-symmetric package is analyzed. Geometric nonlinearity is taken into account by the method of initial strains.

The graphical relationship of displacement – force is obtained.

The obtained results are used in the process of design of package elements.

References

1. Lithuanian-Ukrainian research project: Study of Special Printing and Packaging Production Technologies, Considering their Ecological and Operational Qualities (No. V-23/2007, No. V-36/2008).
2. **Kibirkštis, E., Lebedys, A., Kabelkaitė, A., Havenko, S.** Experimental study of paperboard package resistance to compression. -Mechanika. -Kaunas: Technologija, 2007, No.1(63), p.27-33.
3. **Kabelkaitė, A., Kibirkštis, E., Ragulskis, L.** Investigation of compression of packages. -Journal of Vibroengineering, 2008, v.10, issue 1, p.104-113.
4. **Kibirkštis, E., Mizyuk, O., Havenko, S.** Compressive strength of flock-coated packages. -Mechanika. -Kaunas: Technologija, 2008, No.4(72), p.28-33.
5. **Kibirkštis, E., Lebedys, A., Dabkevičius, A., Maik, V.** Experimental study of polystyrene packaging compression resistance. -Mechanika. -Kaunas: Technologija, 2007, No.3(65), p.22-29.
6. **Alhamati, A.,A.,N., Ghazali, A.,H., Mohammed, J.,N.,T.,A., Kadir, M.,R.,A.** Investigation on the behavior of rigid polivinylchloride pipes subjected to uniaxial compression load. -American Journal of Applied Sciences, 2006, No.3(7), p.1916-1923.
7. **Partaukas, N., Bareišis, J.** The stress state in two-layer hollow cylindrical bars. -Mechanika. -Kaunas: Technologija, 2009, No.1(75), p.5-12.
8. **Nygårds, M., Hallbäck, N., Just, M., Tryding, J.** A finite element model for simulations of creasing and folding of paperboard. -ABAQUS User's Conference 2005. <http://www.simulia.com/> (visited 5th March 2009).

9. **Žiliukas, A.** Plate buckling under complex loading. -Mechanika. -Kaunas: Technologija, 2008, No.6(74), p.17-20.
10. **Zienkiewicz, O.,C.** The Finite Element Method in Engineering Science. -Moscow: Mir, 1975. -520p. (in Russian).
11. **Gallagher, R.,H.** Finite Element Analysis Fundamentals. -Moscow: Mir, 1984.-420p. (in Russian).
12. **Bathe, K.,J.** Finite Element Procedures in Engineering Analysis. -New Jersey: Prentice-Hall, 1982.-735p.

E. Kibirkštis, V. Bivainis, L. Ragulskis, A. Dabkevičius

CILINDRO FORMOS KARTONINIŲ PAKUOČIŲ TYRIMAI

R e z i u m ė

Skaitmeniniais metodais, naudojant trimačius elementus, ištirtas cilindro formos kartono pakuotės, kaip kevalo tipo konstrukcijos, stabilumas.

Atlikti cilindro ir stačiakampio formos kartoninių pakuočių eksperimentiniai tyrimai. Nustatyta formos - cilindro ir stačiakampio - įtaka pakuotės mechaninėms charakteristikoms. Parodyta, kad cilindrinė pakuotė atlaiko apie 2.4 karto didesnę vertikaliąją ašinę gniuždymo apkrovą, nei stačiakampė, panašios masės ir geometrinių parametrų pakuotė. Atlikti naudojamos medžiagos - kartono savybių įtakos pakuotės atsparumui gniuždymui tyrimai. Pateiktas skaitmeninių cilindrinės pakuotės tyrimų duomenų ir eksperimentinių tyrimų rezultatų, taip pat pakuočių šoninio paviršiaus deformacijų pobūdžio palyginimas. Gauti tyrimų rezultatai taikomi pakuotėms projektuoti.

E. Kibirkštis, V. Bivainis, L. Ragulskis, A. Dabkevičius

INVESTIGATION OF COMPRESSION OF CYLINDRICAL PACKAGES

S u m m a r y

The problem for the analysis of stability of a package of cylindrical shape as of a shell type structure is solved using three dimensional elements.

Experimental investigations of cardboard packa-

ges of cylindrical and rectangular shape are performed. The influence of package shape – cylinder or rectangle - to its mechanical characteristics is determined. It is determined that the package of cylindrical shape resists the axial load, which is about 2.4 times higher when compared with the package of rectangular type of the similar mass and geometrical parameters. The influence of the qualities of the used material (cardboard) to the strength of compression of the packages is investigated. The comparison of the numerical and experimental investigation of packages is performed and the character of deformations of the packages surface is compared. The obtained results are used in the process of package design.

Э. Кибиркштис, В. Бивайнис, Л. Рагульскис, А. Дабквичюс

ИССЛЕДОВАНИЕ СЖАТИЯ ЦИЛИНДРИЧЕСКИХ УПАКОВОК

Р е з ю м е

Устойчивость цилиндрической формы упаковки, как оболочки из картона, исследовано численными методами используя трехмерные элементы.

Проведены экспериментальные исследования упаковок цилиндрической и прямоугольной формы. Установлено влияние формы упаковки – цилиндра или прямоугольника - на механические характеристики упаковки. Установлено, что цилиндрическая упаковка выдерживает на 2.4 раза большую вертикальную нагрузку сжатия, чем прямоугольная упаковка примерно той же массы и геометрических параметров. Исследовано влияние свойств используемого материала- картона на прочность при сжатии упаковки. Приведено сравнение численных результатов исследований цилиндрической упаковки с результатами экспериментальных исследований, и также характера деформаций боковой поверхности упаковок. Результаты исследований применяются при проектировании упаковок.

Received March 16, 2009

Accepted May 11, 2009

DOI: 10.5755/j02.mech.15231