

# Study of design, kinematics and accuracy modelling of 3 degrees of freedom robot

C. Szep\*, S.-D. Stan\*\*, V. Csibi\*\*\*, R. Bălan\*\*\*\*

\*Technical University of Cluj-Napoca, C. Daicoviciu no. 15, 400020 Cluj-Napoca, Romania,

E-mail: szep\_crysty84@yahoo.com

\*\*Technical University of Cluj-Napoca, C. Daicoviciu no. 15, 400020 Cluj-Napoca, Romania,

E-mail: sergiustan@ieee.org

\*\*\*Technical University of Cluj-Napoca, C. Daicoviciu no. 15, 400020 Cluj-Napoca, Romania,

E-mail: csibiven@yahoo.com

\*\*\*\*Technical University of Cluj-Napoca, C. Daicoviciu no. 15, 400020 Cluj-Napoca, Romania,

E-mail: radubalan@yahoo.com

## 1. Introduction

Improvement of the accuracy modelling has been a topic of interest in the last years due to its importance in the calibration process and especially in the case of serial robots with significant errors [1-5].

First is presented the kinematic modelling of the studied robots, then a general modelling of errors in serial robot chain is applied and generated for 3 DOF serial robot.

The model is based on the use of error Jacobian matrices. By the error model, the end-effector positioning and accuracy can be more accurately estimated. Jacobian matrix was also used in obtaining errors [6-8].

Robot calibration is a process during which robot accuracy can be improved by modifying the robot positioning software, i.e. identifying a more accurate functional relationship between the joint variable and the actual position of the end-effector in workspace and using these identified changes to update the robot positioning software rather than altering the structure design of the robot or its control system.

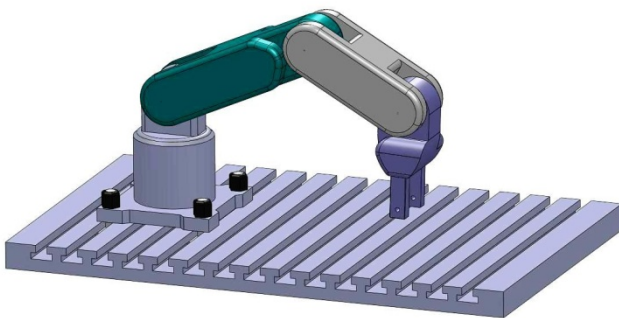

Fig. 1 3 DOF serial robot

In general, in the structure of the industrial robots, we find kinematic joints with 5 degrees of freedom (rotation **R** or translation **T**). These joints are practically realized as motor joints in a modular form. The position and orientation of a robot's end-effector are derived from the joint positions by means of a geometric model of the robot arm. For serial robots, the mapping from joint positions to end-effector pose is easy; the inverse mapping is more difficult. Therefore, most industrial robots have special designs that reduce the complexity of the inverse mapping. Their main disadvantages are:

- the low stiffness inherent to open kinematic structure;
- errors are accumulated and amplified from link to link;
- the fact that they have to carry and move large weight of most of the actuators.

As it was demonstrated, robot accuracy can be improved, without structural or constructive improvements, through calibration, that permits the use in the control process of a correct model, more accurately related to the real robot.

## 2. Direct kinematics problem (DKP)

In the next section the direct kinematic problem for 3 DOF robot with 3 rotation joints (Fig. 1) is presented. The kinematic equations of the end-effector are given by

$$\begin{aligned} x &= L_1 \cos(q_1) + L_2 \cos(q_1 + q_2) + L_3 \cos(q_1 + q_2 + q_3) \\ y &= L_1 \sin(q_1) + L_2 \sin(q_1 + q_2) + L_3 \sin(q_1 + q_2 + q_3) \end{aligned} \quad (1)$$

The general Jacobian matrix looks like this

$$J = \begin{pmatrix} \frac{\partial k_1}{\partial q_1} & \frac{\partial k_1}{\partial q_2} & \dots & \frac{\partial k_1}{\partial q_3} \\ \frac{\partial k_2}{\partial q_1} & \frac{\partial k_2}{\partial q_2} & \dots & \frac{\partial k_2}{\partial q_3} \\ \frac{\partial k_3}{\partial q_1} & \frac{\partial k_3}{\partial q_2} & \dots & \frac{\partial k_3}{\partial q_3} \end{pmatrix} \quad (2)$$

The Jacobian matrix of the 3 DOF serial robot is

$$J(q_1, q_2, q_3) = \begin{pmatrix} \frac{\partial x}{\partial q_1} & \frac{\partial x}{\partial q_2} & \frac{\partial x}{\partial q_3} \\ \frac{\partial y}{\partial q_1} & \frac{\partial y}{\partial q_2} & \frac{\partial y}{\partial q_3} \end{pmatrix} \quad (3)$$

where

$$\frac{\partial x}{\partial q_1} = -L_1 \sin(q_1) - L_2 \sin(q_1 + q_2) - L_3 \sin(q_1 + q_2 + q_3)$$

$$\frac{\partial x}{\partial q_2} = -L_2 \sin(q_1 + q_2) - L_3 \sin(q_1 + q_2 + q_3)$$

$$\frac{\partial x}{\partial q_3} = -L_3 \sin(q_1 + q_2 + q_3)$$

$$\frac{\partial y}{\partial q_1} = L_1 \cos(q_1) + L_2 \cos(q_1 + q_2) + L_3 \cos(q_1 + q_2 + q_3)$$

$$\frac{\partial y}{\partial q_2} = L_2 \cos(q_1 + q_2) + L_3 \cos(q_1 + q_2 + q_3)$$

$$\frac{\partial y}{\partial q_3} = L_3 \cos(q_1 + q_2 + q_3).$$

### 3. Error modeling

Kinematic modeling and error modeling are established with all errors using Jacobian matrix method for the 3 link serial robot. In error analysis, error sensitivity is represented by the Jacobian matrix. The Jacobian approximation method is established. Using this method, error analysis, calibration, compensation, and on-line control model can be established.

In the next paragraph the Jacobian will be used to find the effect of errors in the joint angles. An error of  $\Delta q$  in joint angles will produce positional error of  $\Delta x = J \Delta q$ . The effect of errors will be different at different position, because the map is nonlinear.

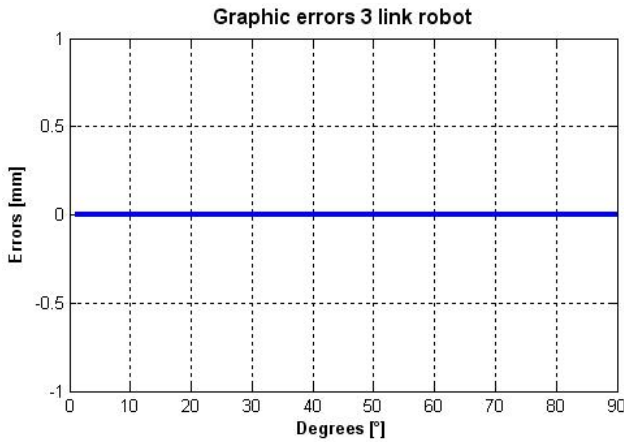

Fig. 2 Graphic errors for 3 link serial robot

For the first case we will consider that the planar manipulator is in position:  $q_1 = q_2 = q_3 = 0$ . The graph will look like this when the error does not exist (Fig. 2). All the links are aligned horizontally.

To the first order, no joint error can produce an error in the x-direction. An error of  $1/10$  of a radian in  $q_2$ ,  $\Delta q = (0, 0.1, 0)^T$ , will give a y-error of

$$\delta y \approx 0.1(L_2 + L_3) \quad (4)$$

In a different example, when,  $q_1 = q_3 = 0$ ,  $q_2 = \frac{\pi}{2}$ , the Jacobian matrix will look like this

$$J\left(0, \frac{\pi}{2}, 0\right) = \begin{pmatrix} -L_2 - L_3 & -L_2 - L_3 & -L_3 \\ L_1 & 0 & 0 \end{pmatrix} \quad (5)$$

Graphic errors for 3 link serial robot are presented in the Figs. 2 - 4. In Fig. 3, every different type of lines presents the values of position error for the three joints.

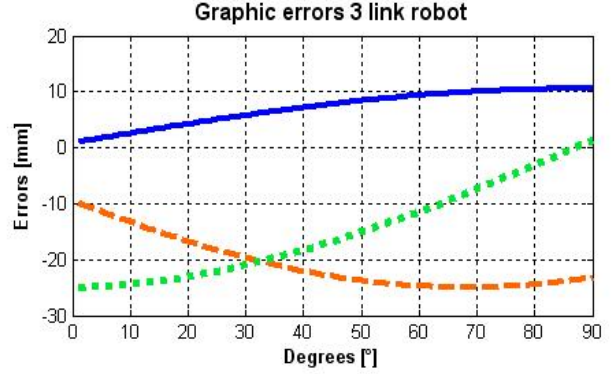

Fig. 3 Graphic errors for 3 link serial robot

Now putting an error in  $\Delta q = (0, 0.1, 0)^T$ , will give a positional error of

$$\Delta x \approx J\left(0, \frac{\pi}{2}, 0\right) \Delta q = \begin{pmatrix} -\frac{1}{10(L_2 + L_3)} \\ 0 \end{pmatrix} \quad (6)$$

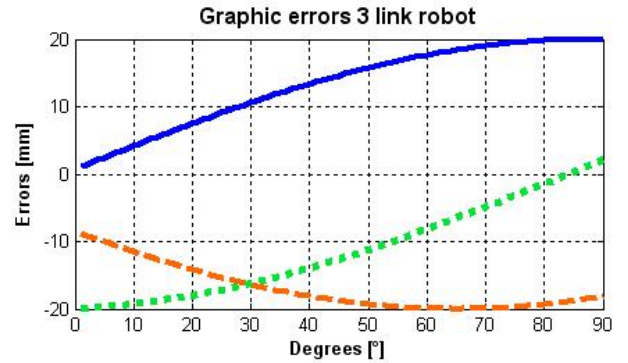

Fig. 4 Graphic errors for 3 link serial robot

In Fig. 4, every different type of lines presents the values of position error for the three joints.

The forward and inverse kinematics problems were solved under the MATLAB environment and it contains a user friendly graphical interface.

The user can visualize different solutions and different geometric parameters of the robot can be modified to investigate their effect on kinematics of the robot.

This graphical user interface can be a valuable and effective tool for the accuracy analysis and kinematics of parallel robots (Fig. 5).

The designer can enhance the performance of his design using the results given by the presented graphical user interface.

The MATLAB-based program is written to compute the forward and inverse kinematics as well as Jacobian matrix value, and computed errors of the serial robot with 3 degrees of freedom. Computed errors at given de-

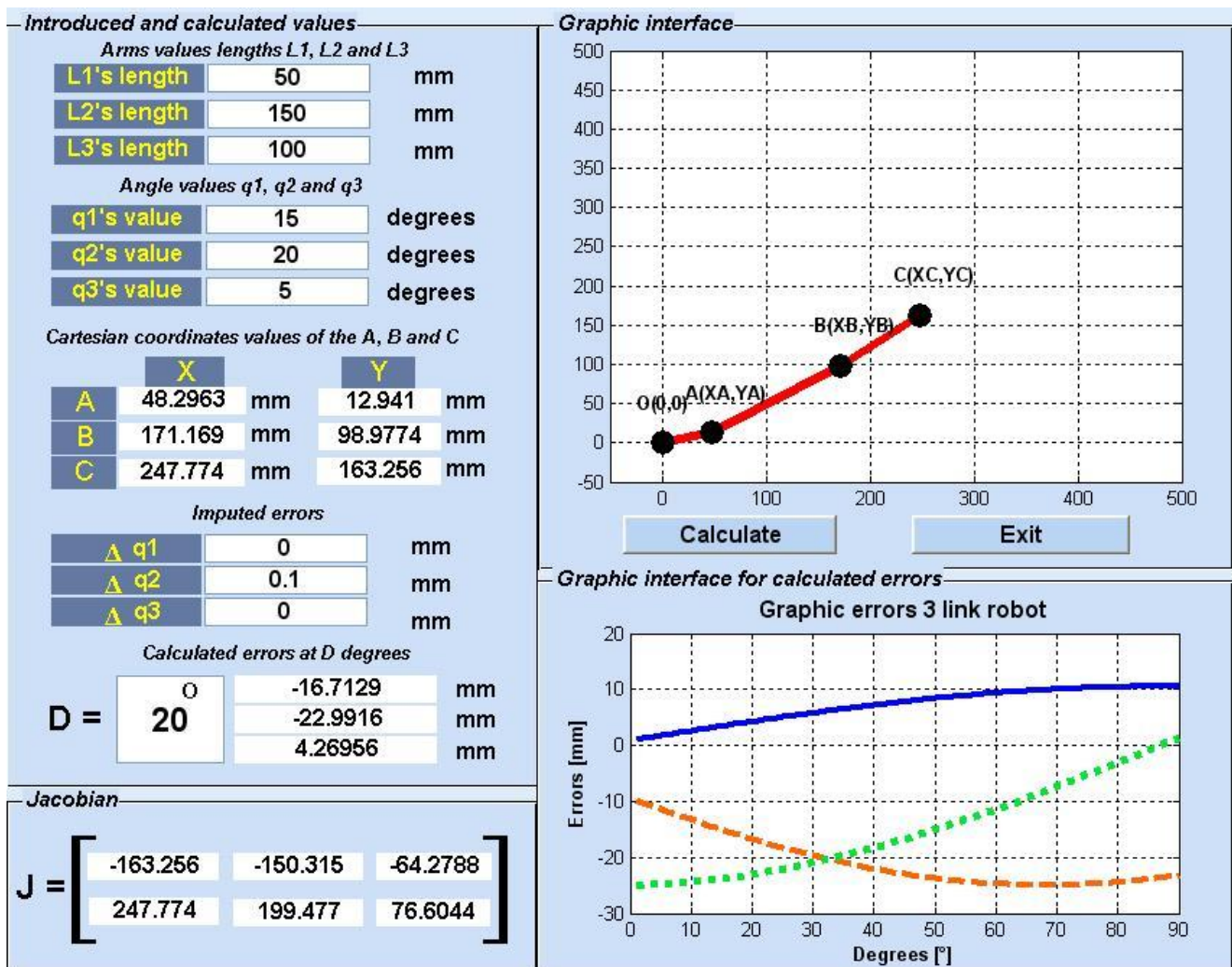

Fig. 5 Graphical User Interface for design, kinematics and error modelling of 3 link serial robot

degrees can be read directly from the Graphical User Interface. Resulted error graphics is shown in the right-down corner of the Graphical User Interface. Every type of line represents a calculated error.

Briefly, according to the present paper, a method and system for computing and modeling the errors of the end-effector of a 3 DOF robot is proposed.

#### 4. Conclusions

In this paper, the kinematic modeling and error modeling are performed with all errors considered using Jacobian matrix method for the robot. Based on the precision modeling and numerical simulations made on a 3 link serial robot, it was drawn the following conclusions: accuracy modeling of robot errors and its application is presented in first part of the paper. The definition of the robot accuracy is usually related to robot positioning, so that the accuracy is defined as a measure of robot ability to attain a required position with respect to a fixed absolute reference coordinate frame. Such a definition is easily extended to trajectory tracking. Then, the accuracy can be defined as a measure of robot ability to track the prescribed trajectory with respect to the absolute coordinate frame.

#### 5. Acknowledgment

This work was financially supported by CNMP through the grants no. 3280 (PARTENERIATE type), title of the project "Complex mechatronics systems for medical applications" and CNCISIS 1072 (IDEI type), title of the project 'Researches regarding the advanced control with applications in mechatronics'.

#### References

1. Stan, S.-D., Manic, M., Mătieș, M., Bălan, R. Evolutionary approach to optimal design of 3 DOF translation exoskeleton and medical parallel robots. -HSI 2008, IEEE Conference on Human System Interaction. -Krakow, Poland, May 25-27, 2008, p.720-725.
2. Stan, S., Mătieș, V., Bălan, R. Optimal design of 2 DOF Parallel Kinematics Machines. -Berlin: Willey PAMM, 2006, p.705-706.
3. Brisan, C., Rusu, C. Aspects concerning modeling of self-reconfigurable parallel robots. -Mechanika. -Kaunas: Technologija, 2008, Nr.1(69), p.59-62.
4. Tatar, O., Mandru, D., Ardelean I. Development of mobile minirobots for in pipe inspection tasks. -Mechanika. -Kaunas: Technologija, 2007, Nr.6(68), p.60-64.
5. Stan, S.-D. R. Bălan, V. Mătieș. Modelling, design

- and control of 3DOF medical parallel robot. -Mechanika. -Kaunas: Technologija, 2008, Nr.6(74), p.68-71.
6. **Stan, S.-D., Manic, M., Mătieș, M., Bălan, R.** Kinematics analysis, design, and control of an Isoglide3 parallel robot (IG3PR). -IECON 2008, The 34th Annual Conference of the IEEE Industrial Electronics Society.- Orlando, USA, November 10-13, 2008.
  7. **Neagoe, M., Gogu, G., Diaconescu, D.** High degree accuracy modelling and calibration of serial robots with large errors. -Product Engineering. -Springer-Verlag, p.397-408.
  8. **Gogu, G.** Structural synthesis of fully-isotropic translational parallel robots via theory of linear transformations. -European Journal of Mechanics, A –Solids, 2004, v.23, p.1021-1039.

C. Szep, S.-D. Stan, V. Csibi, R. Bălan

#### TRIJŲ LAISVĖS LAIPSNIŲ ROBOTO KONSTRUKCIJOS, KINEMATIKOS IR TIKSLUMO MODELIAVIMO TYRIMAI

##### R e z i ū m ė

Neturintys specialaus teorinio paruošimo roboto kinematikos derinimo metodai iššaukia jo kinematinio modelio linijines diferencialines paklaidas. Šis modelis parremtas Jakobino tiesioginiu kinematinium modeliu, atsižvelgiant į kuriamo modelio parametrus. Roboto tikslumas susijęs su jo pozicionavimu, jis nusakomas roboto gebėjimu pasiekti reikalingą padėtį atžvilgiu fiksuotos absoliutinės koordinačių sistemos tam tikru dydžiu. Toks apibrėžimas lengvai išplečiamas į trajektorijos sekimą. Taigi roboto tikslumas gali būti apibrėžiamas kaip jo gebėjimas sekti reikiamą trajektoriją atžvilgiu absoliutinės fiksuotos koordinačių sistemos tam tikru matu.

C. Szep, S.-D. Stan, V. Csibi, R. Bălan

#### STUDY OF DESIGN, KINEMATICS AND ACCURACY MODELLING OF 3 DEGREES OF FREEDOM ROBOT

##### S u m m a r y

Practical methods of kinematic's calibration make use of the linear differential error of the kinematics' model.

This model is based on the Jacobian of direct kinematics' model with respect to the parameters of this model. The definition of robot accuracy is usually related to robot positioning, so that the accuracy is defined as a measure of robot ability to attain a required position with respect to a fixed absolute reference coordinate frame. Such a definition is easily extended to trajectory tracking. Then, accuracy can be defined as a measure of robot ability to track the prescribed trajectory with respect to the absolute coordinate frame.

Ц. Сзеп, С.-Д. Стан, В. Цсиби, Р. Балан

##### Р е з ю м е

#### ИССЛЕДОВАНИЯ МОДЕЛИРОВАНИЯ КОНСТРУКЦИИ, КИНЕМАТИКИ И ТОЧНОСТИ РОБОТА С ТРЕМЯ СТЕПЕНЯМИ СВОБОДЫ

##### Р е з ю м е

Практические методы кинематической настройки робота без специальной теоретической подготовки вызывают линейные дифференциальные погрешности его кинематической модели. Эта модель обоснована на прямой кинематической модели Якобиана с учетом параметров создаваемой модели. Точностная характеристика робота связана с позиционированием, так как точность определяется его способностью достичь заданного положения относительно фиксированной абсолютной системы координат с определенной величиной. Такое определение легко расширяется до траектории слежения. Таким образом точность робота может быть характеризована его способностью следить за заданной траекторией относительно абсолютной системы координат с определенной величиной.

Received December 22, 2008

Accepted April 20, 2009

DOI: 10.5755/j02.mech.15234