

## Finite element analysis of three-hole socket with a shutter

Tong Yifei\*, Li Dongbo\*\*, Yu Fei\*\*\*, He Yong\*\*\*\*

\*Nanjing University of Science and Technology, School of Mechanical Engineering 402, 210094 Nanjing, People's Republic of China, E-mail: tyf51129@yahoo.com.cn

\*\*Nanjing University of Science and Technology, School of Mechanical Engineering 402, 210094 Nanjing, People's Republic of China, E-mail: db\_callar@yahoo.com.cn

\*\*\*Nanjing University of Science and Technology, School of Mechanical Engineering 226, 210094 Nanjing, People's Republic of China, E-mail: feiyu.2008@163.com

\*\*\*\*Nanjing University of Science and Technology, School of Mechanical Engineering 402, 210094 Nanjing, People's Republic of China, E-mail: yhe1964@mail.njust.edu.cn

### 1. Introduction

Socket is an important low voltage electrical component, which is the key link of obtaining electric power as a daily necessity. The security of sockets is always focused on when being used. Traditional sockets have the biggest security risk of electric shock, imperfect contact and ablation [1]. The presser-ability against electric shock is one of the important indexes of socket security performance. So it is of importance to research on the three-hole socket with a shutter by means of finite element analysis [2, 3].

The present work was carried out in order to obtain simulation data of the socket. In the next section, the structure of three-hole socket with a shutter is described as well as its operation principles. FE model of three-hole socket with a shutter is developed using commercial program LS-DYNA [4-6] in Section 3. The results of finite element analysis are given and discussed in Section 4. Finally, research conclusions are summarized.

### 2. Description of the three-hole socket with a shutter

Three-hole socket with a shutter is mainly composed of a shutter, a spring, a bolt and a sleeve, whose structure is added with a shutter design on the basis of three-hole socket so as to increase the security performance. Compared with common sockets, three-hole socket has the following advantages:

- when ready for use, the plug socket is closed by the shutter, which can prevent bodies or other objects from touching the conductor in the hole against electric shock;
- when the plug is pulled out, the plastic chip in the sockets will automatically cover the plug socket, thus the socket is dust-free.

The structure of three-hole socket with a shutter is illustrated briefly in Fig. 1. The bolt through the plug socket

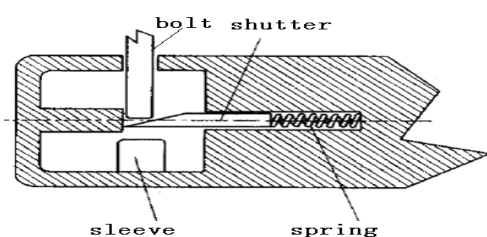

Fig. 1 Brief sketch map of three-hole socket with a shutter

act on the bevel of the shutter vertically. The decomposed horizontal thrust push the spring, then the shutter opens and the bolt plugs into the sleeve. When the bolt is pulled out, the resilience acts on the shutter and make it close.

### 3. Development of FE model of three-hole socket with a shutter

Before FE analysis on the socket, its structure should be simplified. Then select suitable unit type or unit combination to partition reason mesh and define constraints so as to conform the developed FE model to its structure itself. The simplified structure model is shown in Fig. 2.

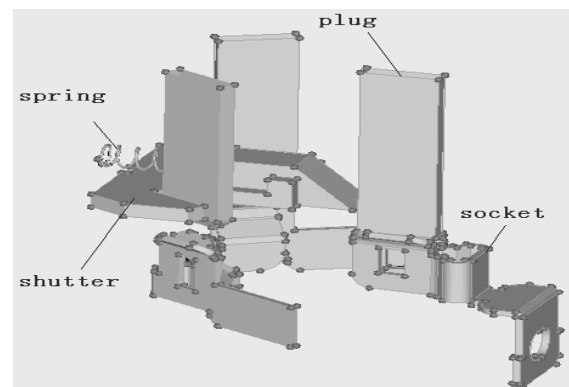

Fig. 2 Simplified structure model of three-hole socket with a shutter

#### 3.1. Mesh partitioning of three-hole socket with a shutter

Relatively complex components are selected to be reported in this paper.

- Mesh partitioning of the ram.

Geometric model of the ram is given in Fig. 3.

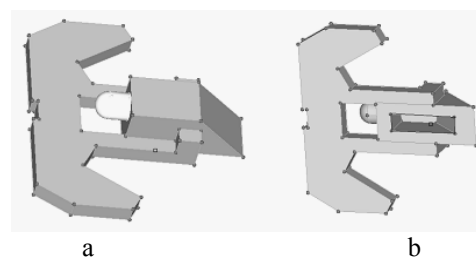

Fig. 3 Geometric model of the ram: a - front view; b - back view

From Fig. 3, a it can be seen that the cylinder is only to constrain the spring's freedom, so the cylinder can be omitted. The hole in Fig. 3, b won't cause any effects in working conditions, so it can be seamed.

The mesh partitioning of the ram is shown in Fig. 4.

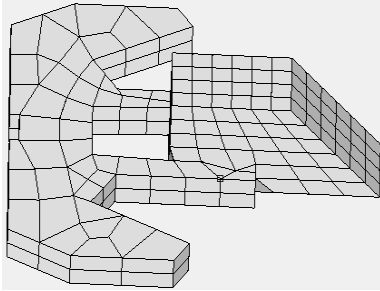

Fig. 4 Mesh partitioning of the ram

- Mesh partitioning of the spring.

The spring is an important component of three-hole socket with a shutter, and its demand of mesh partitioning is relatively high because it is very thin. Owing to the irregular shape of the spring end and the trend of the spring axis lessening, "Solid map" is used to partition the spring end firstly and the steps are as follows:

- 1) partition two-dimensional mesh of the face shown in Fig. 5, a using "Spline";
- 2) make the line shown in Fig. 5, b combination with the cylinder into a face;
- 3) set the parameters of each face shown in Fig. 5, c using "Solid map";
- 4) generate the meshes as in Fig. 5, d.

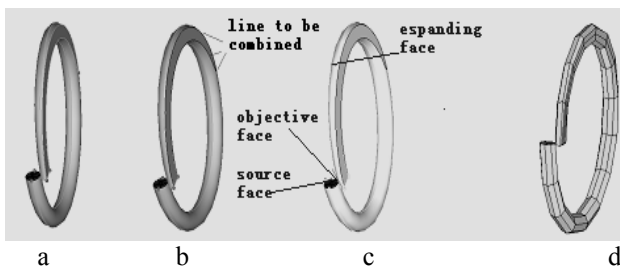

Fig. 5 Partition of the spring end: a – step 1; b – step 2; c – step 3; d – step 4

Secondly, "Line drag" is used to partition the helical cylinder. Here, two-dimensional unit is the source face mesh generated above and a centre line as in Fig. 6 is generated to stretch the two-dimensional mesh. Finally, set the tolerance parameter be 0.01 using "edges" panel and search the coincident nodes using "Preview equiv" and seam the nodes found using "equivalence" so that the end and the cylinder of the spring can be combined and processed as the spring. The partitioned result is shown in Fig. 7.

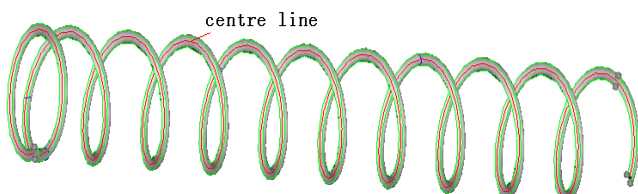

Fig. 6 Centre line to sketch two-dimensional mesh

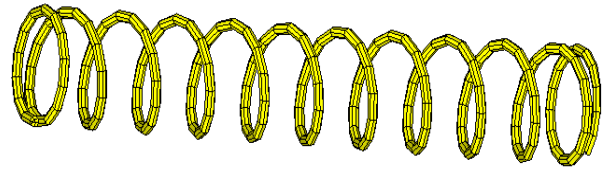

Fig. 7 Mesh partitioning of the spring

- Mesh partitioning of the socket.

Shell unit is used to partition the socket. Generate a neuter faces using "midsurf" panel as in Fig. 8 and partition two-dimensional mesh of the neuter faces as in Fig. 9. Then reflect the left neuter face and the overall mesh model of the socket can be obtained as shown in Fig. 10.

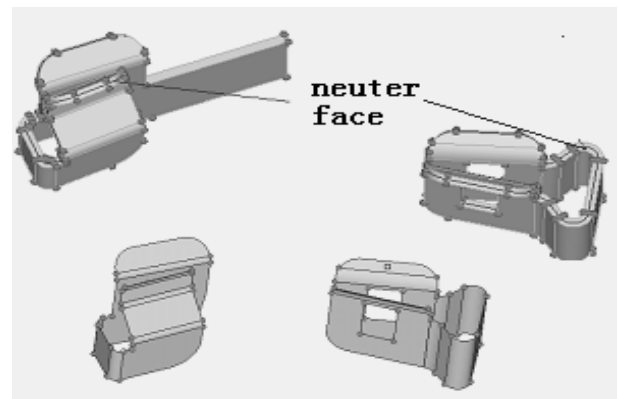

Fig. 8 Neuter faces generation

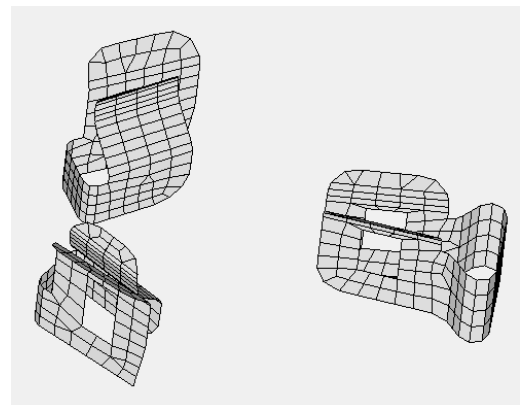

Fig. 9 Mesh partitioning and reflection of the neuter face

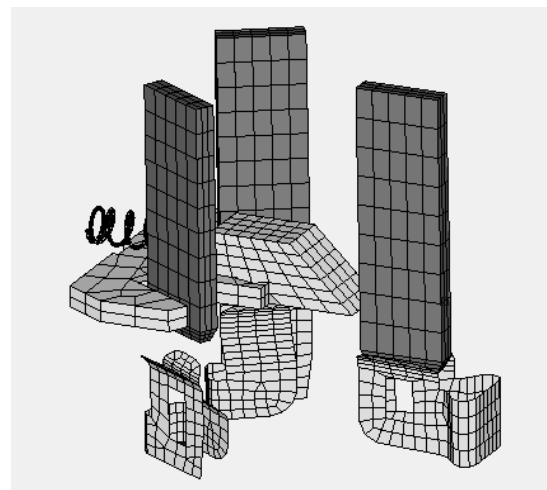

Fig. 10 Overall mesh model of the socket

### 3.2. Loading and solving

- Materials definition.

In our research, the materials of the plug, socket and spring are defined as bronze, whose parameters are as follows:

Rho(density): $8.8 \times 10^3 \text{ kg/m}^3$ ;  
 E:  $130 \text{ KN/mm}^2$ ;  
 Nu: 0.2.

The material of the ram is defined as engineering plastic and its parameters are as follows:

Rho(density): $1.2 \times 10^3 \text{ kg/m}^3$ ;  
 E:  $10 \text{ KN/mm}^2$ ;  
 Nu: 0.2.

The units of the plug, spring and ram are processed using “section\_solid” and the socket using “section\_shell”. Also the contact between the plug and socket is defined as well as the contact between the spring and the ram.

- Constraint loading:
  1. the socket root is fixed;
  2. the plug can move only in the direction of Y;
  3. the ram can move only along the spring;
  4. the spring can only expand and contract in the direction of its axis.
- Force loading.

In our research, the force is relatively complex. After detailed analyzing the simulation process, the operation starting time, ending time, distances and direction can be seen. The contexts of the spring load curve are as follows:

```
xydata,
0e0,0e0
5e-1,-1.1e0
3.5e0,-1.1e0
Endata
```

and the contexts of the plug load curve are as follows:

```
xydata,
5e-1,0
2.5e0,-1.6e1
Endata
```

The process of the loading according to the above contexts is illustrated in Fig. 11. Here, the red line is spring load curve and the black line is plug load curve. It can be seen easily that the spring remains pre-tightened with the pre-tightening distance equalling to 1.1 mm before the plug operating and then the plug move 16 mm toward the direction of Y.

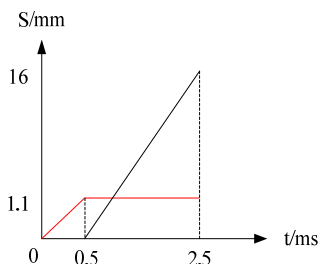

Fig. 11 Illustrative graph of loading process

- Solving.

Firstly, set parameters using “control card” panel and then generate “\*.Key” file used for solving to output the solving results [7].

### 4. Results and discussion

The stress during the whole plugging procedure can be obtained through Is-prepost as in Fig. 12. Here, the unit of strain values is GPa.

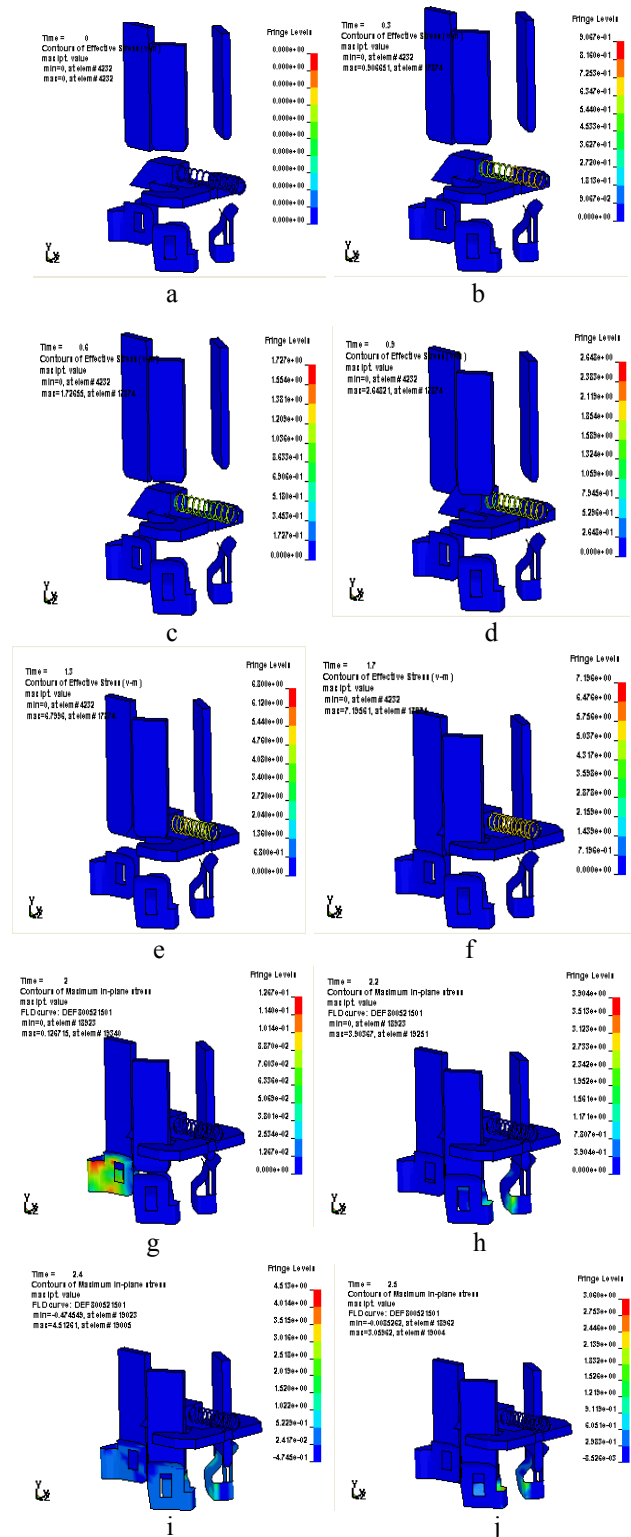

Fig. 12 Stress diagram during the whole plugging procedure: a - time=0; b - time=0.3; c - time=0.6; d - time=0.9; e - time=1.3; f - time=1.7; g - time=2; h - time=2.2; i - time=2.4; j - time=2.5

After analyzing the stress diagram, stress concentration can be found as marked in red in Fig. 13.

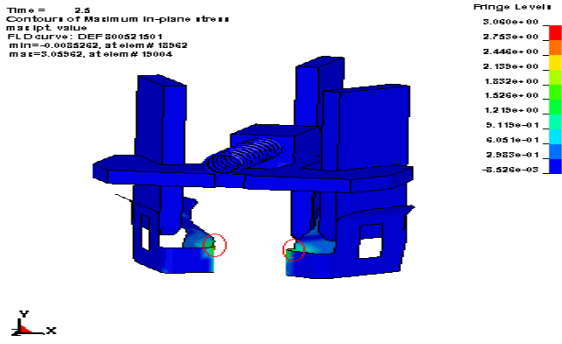

Fig. 13 Stress concentration during the whole plugging procedure

➤ The thrust opening the shutter calculation.  
 Open the node force file "nodfor.txt" and search the force of nodes on the spring as shown in Table 1. Here, the force refers to the node force of z direction.

Table 1  
 Force record of nodes on the spring

NODE	FORCE, N	NODE	FORCE, N
1575	5.7	1580	5.8
1576	5.7	1581	5.7
1577	5.6	1582	5.7
1578	5.6	1583	5.7
1579	5.7	1584	5.7
Average	5.7		

From the force analysis diagram as shown in Fig. 14, the relationship between the forces acting on the shutter can be concluded easily. That is

$$F \sin^{-1} \theta = T$$

where  $F$  denotes the thrust,  $T$  denotes the node force of z direction,  $N$  denotes the sustentation from the base and  $\theta$  equals to  $41.6^\circ$ . According to Table 1,  $T$  equals to 5.7 N, then the thrust  $F$  equals to 8.58 N.

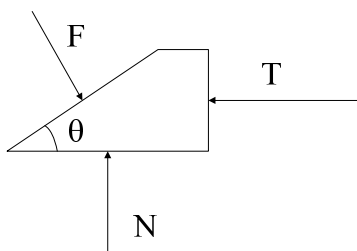

Fig. 14 Force diagram of the shutter

It can be concluded that the vertical force  $F$  acting on the shutter decreases with  $\theta$  increasing. If  $\theta$  is too large, the bolt can easily push and make the shutter open and the shutter will lose the function of guarding against electric shock; if  $\theta$  is too small,  $F$  will increase and as well as the difficulty of opening the shutter and the shutter will be easy of breaking down. So, the force  $F$  can be controlled by adjusting  $\theta$  reasonably so as to bring the shutter into reason action of guarding against electric shock.

- The force plugging into the sleeve.

The node force between the three pairs of bolts and sleeves can be found in output file "nodefor.txt". The records of the force of Y direction are given as in Table 2, 3, 4.

Table 2  
 Force record of nodes between bolt1 and sleeve1

NODE	FORCE, N	NODE	FORCE, N
1344	3.2	1349	3.5
1345	3.2	1350	3.5
1346	3.3	1351	3.3
1347	3.4	1352	3.6
1348	3.1	1353	3.2
Average	3.33		

Table 3  
 Force record of nodes between bolt2 and sleeve2

NODE	FORCE, N	NODE	FORCE, N
1921	2.2	1926	3.2
1922	3.0	1927	2.8
1923	2.4	1928	2.4
1924	2.4	1929	2.4
1925	2.8	1930	2.2
Average	2.58		

Table 4  
 Force record of nodes between bolt3 and sleeve3

NODE	FORCE, N	NODE	FORCE, N
2713	2.3	2718	2.0
2714	2.1	2719	2.3
2715	2.3	2720	2.3
2716	2.3	2721	2.4
2717	2.1	2722	2.1
Average	2.11		

Thus, the force plugging into the sleeve by the bolt can be obtained:  $3.33 + 2.58 + 2.11 = 8$  N.

### 5. Conclusions

The work reported here on finite element analysis of three-hole socket with a shutter is an analysis and optimization part of socket products development by the authors and cooperative enterprises. This research seeks to confirm the reasonableness and effectiveness of designed sockets, and to analyze the factors affecting the design parameters and structure so as to provide design references for designers. The main results of this research can be concluded as follows.

1. Finite element analysis results show the stress concentration zero during the whole plugging procedure which can provide reference for structure design and optimization.

2. The shutter angle significantly affects the force during the whole plugging procedure. If the angle  $\theta$  is too large, the bolt can easily push and make the shutter open and the shutter will lose the function of guarding against electric shock, if  $\theta$  is too small, the shutter will be

easy of breaking down.

3. In our research,  $\theta = 41.6^\circ$ . The vertical thrust  $F$  acting on the shutter equals to 8.58 N and the force plugging into the sleeve by the bolt equals to 8 N. The results are conformed to national standard.

4. Designers can reasonably control  $\theta$  to control the spring thrust and the force plugging into the sleeve, and to make full use of the presservability against electric shock.

## References

1. **Xu Zhihong, Zhang Peiming, Lei De.** Development and expectation of low voltage electrical apparatus technology in our country. -Electrotechnical Journal, 2002, 5, p.1-4.
2. **Styles, M., Comston, P., Kalyanasundaram, S.** Finite element modeling of core thickness effects in aluminum foam/composite sandwich structures under flexural loading. -Composite Structures, 2008, 86, p.227-232.
3. **Wang, Z.W., Zeng, S.Q., Yang, X.H., Cheng, C.** The key technology and realization of virtual ring rolling. -Journal of Materials Processing Technology, 2007, 182, p.374-381.
4. **Leslaw Kwasniewski, Hongyi Li, Jerry Wekezer, Jerzy Malachowski.** Finite element analysis of vehicle-bridge interaction. -Finite Element in Analysis and Design, 2006, 42, p.950-959.
5. **Ankenas, R, Barauskas, R.** Finite element investigation on parameters influencing the springback during sheet metal forming. -Mechanika. -Kaunas: Technologija, 2006, Nr.5(61), p.57-61.
6. **Zhao Haiou.** LS-DYNA Mechanical Analysis Guide. -Beijing: Weapon Industry Press, 2003.-793p.
7. **Fedaravicius, A., Saulys, P., Griskevicius, P.** Research of mine imitator interaction with nondeformable surface. -Mechanika. -Kaunas: Technologija, 2008, Nr.6(74), p.25-29.

Tong Yifei, Li Dongbo, Yu Fei, He Yong

## TRIJŲ SKYLIŲ KONTAKTINIO LIZDO SU UŽRAKTU TYRIMAS BAIGTINIŲ ELEMENTŲ METODU

### Reziumė

Kontaktinis lizdas yra svarbi grandis naudojant žemos įtampos elektros energiją. Kontaktinio lizdo saugumui skiriama daug dėmesio. Įprastiniams kontaktiniams lizdams pavojinga elektrinos iškrova, jie sugadinami arba pablogėja kontakto savybės. Vienas pagrindinių kontaktinio lizdo saugumo rodiklių yra jo apsauga nuo elektrinos iškrovos.

Trijų skylių kontaktinį lizdą su užraktu paprastai sudaro slankiklis, spyruoklė, varžtas ir įvorė. Ši konstrukcija taikoma trijų skylių kontaktiniam lizdui, siekiant padidinti jo naudojimo saugumą. Šiame straipsnyje aprašyta įrenginio konstrukcija, veikimo principas. Trijų skylių kontaktinio lizdo su užraktu konstrukcija supaprastinta, kad ją būtų galima tyrinėti baigtinių elementų metodu. Sudarytas trijų skylių kontaktinio lizdo su užraktu baigtinių elementų modelis. Skaidymo tinklo tipai tinkamai pasirinkti pasirink-

tos kompleksinės detalės – slankiklis, spyruoklė, kontaktinis lizdas. Dinaminis procesus modeliuojant baigtinių elementų metodu, kontaktinio lizdo junginėjimo metu pavojingo įtempių koncentracijos nesusidarė. Išanalizuotas ir skaičiuotos jėgos, veikiančios užraktą, spyruoklinę atramą, įvorę. Nustatyti veiksniai, turintys įtakos minėtai jėgai. Modeliavimas ir skaičiavimai rodo, kad konstrukcija atitinka valstybinį standartą, atliktos analizės rezultatais gali remtis projektuotojai.

Tong Yifei, Li Dongbo, Yu Fei, He Yong

## FINITE ELEMENT ANALYSIS OF THREE-HOLE SOCKET WITH A SHUTTER

### Summary

Socket is an important low voltage electrical component, which is the key link of obtaining electric power as a daily necessity. The security of sockets is always focused on when being used. Traditional sockets have the biggest security risks of electric shock, imperfect contact and ablation. The preservability against electric shock is one of the important indexes of socket security performance.

Three-hole socket with a shutter is mainly composed of a shutter, a spring, a bolt and a sleeve, whose structure is added with a shutter design on the basis of three-hole socket so as to increase the security performance. So it is of importance to research on the three-hole socket with a shutter by means of finite element analysis. In this paper, firstly the structure and operation principles of three-hole socket with a shutter are described.

Secondly, the structure of three-hole socket with a shutter is simplified out of finite element analysis necessity. Thirdly, the FE model of three-hole socket with a shutter is developed. Relatively complex components are selected for detailed discussion about mesh partition in this paper including the ram, the spring and the socket. The finite element dynamic simulation results show the stress concentration zero during the whole plugging procedure. Fourthly, the forces acting on the shutter are analyzed and the spring thrust and the force plugging into the sleeve are calculated. Finally the factors affecting the thrust and the plugging force are analyzed. The simulation and calculated results show that the design conforms to the national standard and the analysis can provide design references for designers.

Тонг Ифей, Ли Донгбо, Ю Фей, Ге Йонг

## ИССЛЕДОВАНИЕ КОНТАКТНОГО ГНЕЗДА С ТРЕМЯ ОТВЕРСТИЯМИ И ЗАМКОН МЕТОДОМ КОНЕЧНЫХ ЭЛЕМЕНТОВ

### Резюме

Контактное гнездо является важным звеном при потреблении электричества низкого напряжения и передачи ее мощности потребителю. При употреблении контактного гнезда большое внимание уделяется его безопасности. Для традиционных контактных гнезд электрический разряд является опасным, гнездо пор-

тится или ухудшается его контактные свойства. Одной из основных характеристик безопасности контактного гнезда является его защита от электрического разряда.

В общем случае контактное гнездо с тремя отверстиями и замком состоит из движка, пружины, болта и втулки. Эта конструкция применяется для контактного гнезда с целью увеличения безопасности его пользования. Таким образом, важно его конструкцию исследовать, применяя метод конечных элементов. В этой статье описана конструкция устройства, принцип его действия. Конструкция контактного гнезда с тремя отверстиями упрощена с целью ее исследования методом конечных элементов. Составлена модель конечных элементов контактного гнезда с тремя отверстиями и замком. Для подбора подходящего типа сети раз-

деления подобраны комплексные детали – движок, пружина, контактное гнездо. При моделировании методом конечных элементов динамических процессов, возникающих при переключении контактного гнезда, никаких опасных зон концентрации напряжений напряжения не установлено. Проанализированы и определены силы, действующие на замок, пружинную опору, втулку. Определены факторы, влияющие на упомянутые силы. Моделирование и расчеты показывают, что конструкция соответствует государственному стандарту и результатами произведенных исследований могут пользоваться проектировщики.

Received April 29, 2009

Accepted August 21, 2009

DOI: 10.5755/j02.mech.15273