

The Smart Stick adaptive structure

K. Pilkauskas*, R. Gaidys**, C. Lira***

*Kaunas University of Technology, Mickėvičiaus 37, 442445 Kaunas, Lithuania, E-mail: kestutis.pilkauskas@ktu.lt

**Kaunas University of Technology, Studentų 50, 51368 Kaunas, Lithuania, E-mail: rimvydas.gaidys@ktu.lt

***University of Bristol, Queen's Building, University Walk, BS8 1TR Bristol, UK, E-mail: c.lira@bristol.ac.uk

1. Introduction

Nowadays we observe the development of modern technologies in different fields such as industrial manufacture, transport, services, house facilities, public security, space exploration which stimulate the generation of new conceptual ideas in many fields of engineering. The field which becomes the basic for different mentioned areas is mechatronics. The characteristic (basic) components of mechatronic systems are: actuators, sensors, control systems, interfaces and materials [1-3]. At present in industrial robotic applications the oleo-hydraulic pump system mechanisms is mainly actuated by electromagnetic servo drives. The tendency to use more electro hydraulic motors is observed as well. However such conventional concept represents a major bottleneck towards high precision, light weight, flexible and adaptive component development. The conventional scheme consists of motors, gears, sensors and numerous connectors. Such architecture makes the system complicated and expensive to manufacture. An entire new approach to the robot design, using new types of advanced materials, new actuators, bioinspired or biomimetic structures seems to be the more promising way to obtain a reliable mechatronic system.

Efforts to build precision mechanisms based on elastically deformed frames, elastically hinged structures with the features of mechanical advantages (displacement amplification) results in promising structures for precision engineering [4]. Their integration with micro fluidic systems or basically micro fluidic actuation, as well as active material actuated systems seems to be perspective way for micro mechatronic systems development [5, 6].

With the aim to obtain adaptive structures with

the distributed compliance numerous research attempts are made to develop actuators the functioning features of which mimics biological muscles. Mainly they can be classified into two major groups: actuators based on fluidic principles of operation and actuators based on electro-active polymers.

One of the first well known results in the development of actuators based on fluidic principle is the McKibben Artificial Muscle [7] which contracts like a real muscle developing axial force when pressure is supplied. Its application for robot arm and leg articulation is reported in [8]. The novel type of actuator which consists of two rigid links joined by rotational hinge and inflatable ball placed between them can be used for an ultra light anthropomorphic hand development. The application of fluidic actuator is reported as well in variable structure fabric – the fabric which can change shape or mechanical parameters (stiffness) when actuated [9, 10]. The current research aims to investigate the interaction process of a mini pipe and rigid U-shaped link which serves as a structural unit (or brick) for constructing the adaptive structure “Smart Stick” both at the stage of mini pipe insertion and the operation stage when the mini pipe is inflated using external pressure source.

2. Mechanical design of the module

Mechanical part of the structure under investigation consists of a number of periodically arranged in longitudinal direction U-shaped structural elements (Fig. 1) manufactured of high elasticity material (e.g. alloyed steel).

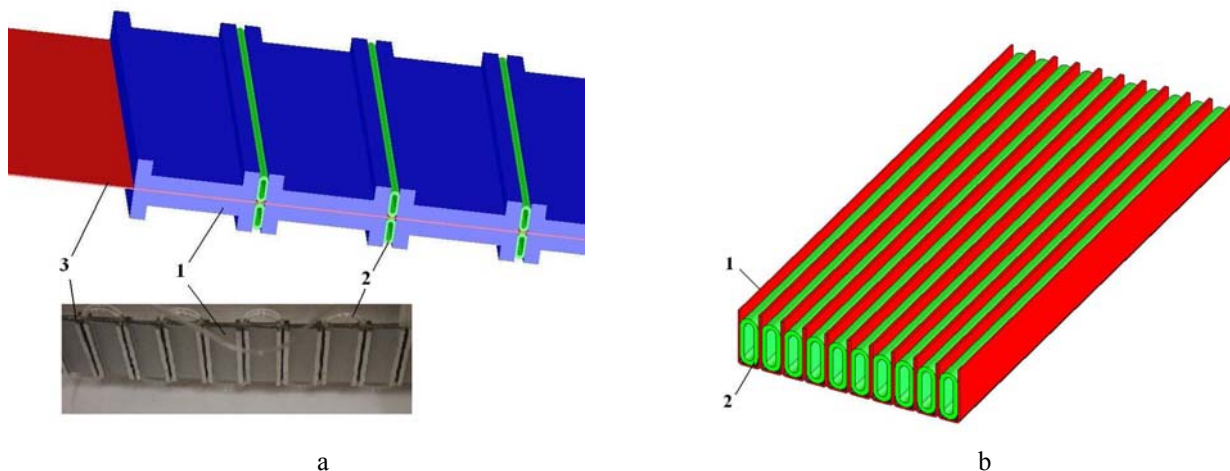

Fig. 1 Mechanical structure of “Smart Stick”: a – embodiment 1: 1 – rigid spacer, 2 – fluidic actuator, 3 – elastic foil; b – embodiment 2: 1 – U-shaped link, 2 – fluidic actuator

The two basic arrangements with the functioning of both of them based on the same operational principle are developed for the investigation (Fig. 2, a, b). The first embodiment employs U-shaped member (link) considered as absolutely rigid body which is rigidly fixed on a foil considered as elastic element in a series manner. A single tube inserted in between the members (links) acts as a fluidic actuator which when inflated expands causing angular displacement of one element with respect to another. Total motion (displacement) of the whole “Smart Stick” is the resultant (sum) of angular displacements of all the structural units (U-shaped spacer – tube - U-shaped spacer).

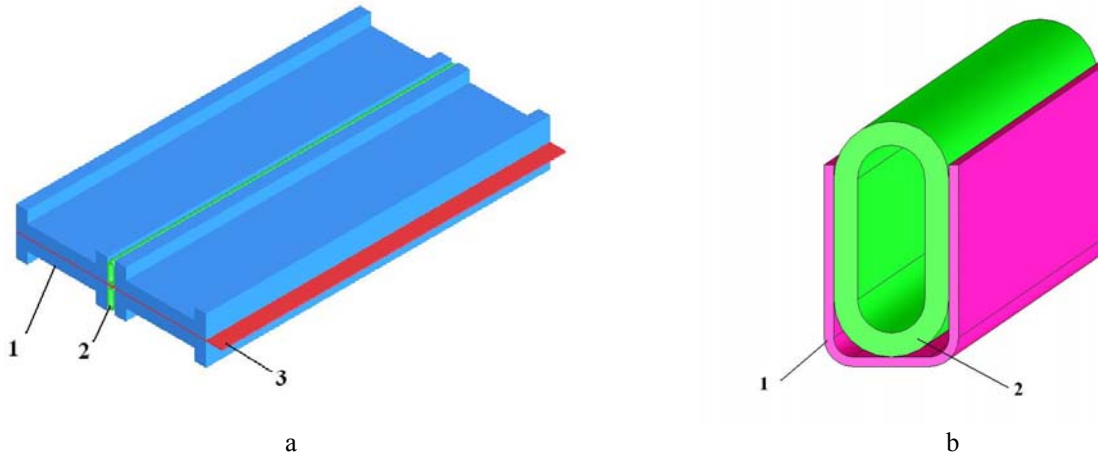

Fig. 2 Elementary unit of “Smart Stick”: a – embodiment 1: 1 – rigid spacer, 2 – fluidic actuator, 3 – elastic foil; b – embodiment 2: 1 – U-shaped link, 2 – fluidic actuator

The application of a single tubular actuator folded in between rigid side parts of U-shaped members is an effective means for actuating the “Smart Stick”. Nevertheless to seek for the best performance circular shape of its cross-section is least favourable and the favourable shape is shown in Fig. 3. Sequentially the tubular actuator should periodically have the second type cross-sections (elliptical shape).

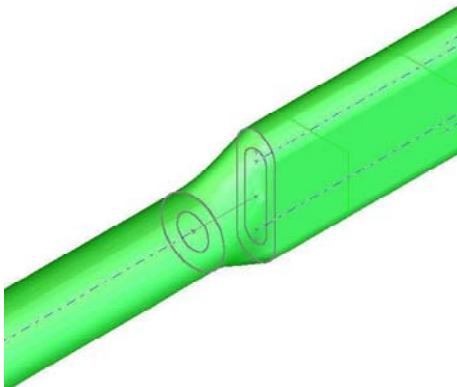

Fig. 3 Cross-section of tubular actuator

Basically the two main cases have been already analysed for functioning principles. According the first case the necessary parts of tubular actuator are initially plastically deformed and in further modelling an assumption of perfect shape as in Fig. 3 was used [11, 12]. According the second assumption a min pipe of circular

The second embodiment employs U-shaped member the side parts of which are relatively thick and the bottom part relatively thin what implies an assumption the side parts to be treated as rigid and the bottom part as elastic. The fluidic actuator in the form of mini tube inserted in between the side parts of U shape when inflated expands causing angular displacement of one side of the U shape with respect to another. The U-shaped links attached rigidly one to another by their sides form the mechanical structure of “Smart Stick”. The resultant displacement (movement) is the sum of angular displacements of all the U-shaped members forming the stick.

cross-section was used and it was elastically deformed (approaching the shape of Fig. 3) during assembly process. Two stages were modelled and simulated – elastic deformation during assembly with no inner pressure and operation stage when the inner pressure was supplied causing angular displacement of the structure [13].

In the current research with the aim of interaction process analysis of the mini tube with rigid element the initially pre-stressed arrangement was analysed. The angle of expansion due to tube insertion into the elastic joint and subsequent inflation is obtained and compared with experimental results.

It is worth mentioning that such arrangement is easy to manufacture and the application of a single tube for actuation avoiding mechanical connectors makes the system simple reliable and light weight.

3. Computational model

Performance of the whole “Smart Stick” is predefined by the behaviour of its single cell – structural unit. For the embodiments of both cases described earlier the single unit can be represented in Fig. 2 FEM analysis of the system shown in Fig. 2, a was performed. The computational model corresponding it is shown in Fig. 4, a. It represents one rigid spacer (embodiment No. 1) or one rigid side of the U element (embodiment No. 2) half of the tube and elastic element (foil or bottom part of U-shaped element) the length of which is half gap width between the spacers or half U span.

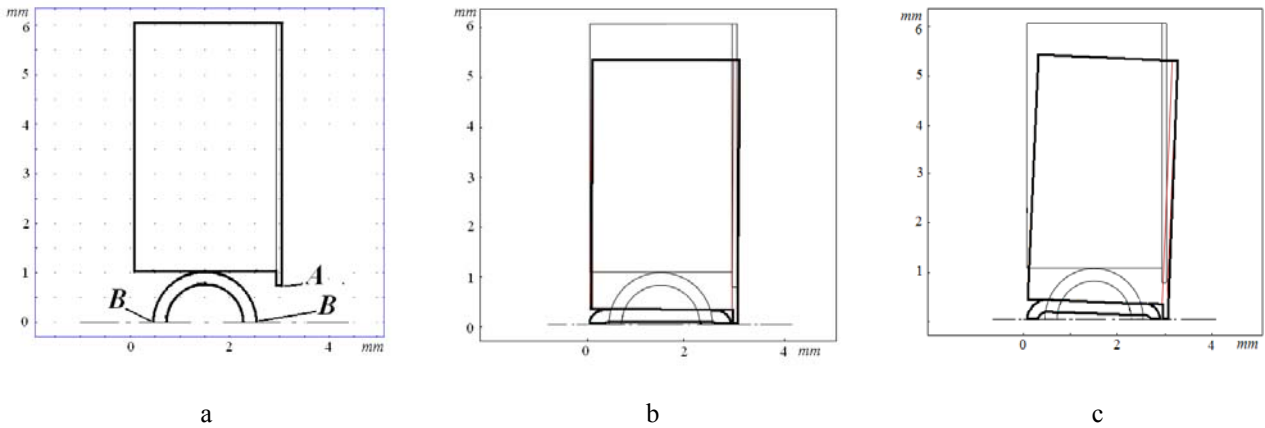

Fig. 4 Simulation of the behaviour of “Smart Stick” single cell: a – initial position; b – the phase of tube insertion; c – the phase of operation

Mechanical characteristics of the materials of U-shaped element are given in Table 1.

Table 1

Element	
Elastic link Material: AISI 301	Fluidic Actuator Material: Polivynil
$E = 193 \text{ GPa}$	$E = 19.3 \text{ MPa}$
$\nu = 0.33$	$\mu = 0.28$
$\rho = 7900 \text{ kg/m}^3$	$\rho = 1010 \text{ kg/m}^3$
$\sigma_y = 352 \cdot 10^6 \text{ Pa}$	$\sigma_y = 17 \cdot 10^6 \text{ Pa}$

The following dimensions were used for simulation with the aim of experimental data benchmark:

- spacer height 2 mm,

- foil thickness 0.1 mm,
- outside diameter of the tube 2.08 mm,
- Tube wall thickness 0.255 mm

The width of the elastic elements is 50 mm.

Behaviour of the cell - elementary unit was analyzed by FEM using the software code FEMLAB 3.1. The first simulation phase - the tube insertion was performed as follows. Assuming that there is no pressure on the inner tube wall at initial position shown in Fig. 4, a the end point A was moved vertically downwards deforming the system elements elastically and allowing the points B of the half tube contour to move freely in horizontal direction (Fig. 4, b). At the second simulation phase – system operation pressure on the inner surface of the half tube was applied further deforming elements of the system (Fig. 4, c) what resulted in angular position change of the spacer after pressure is supplied as shown in Fig. 4, c. Resultant displacements of the system elements for the both simulation phases are shown in Fig. 5.

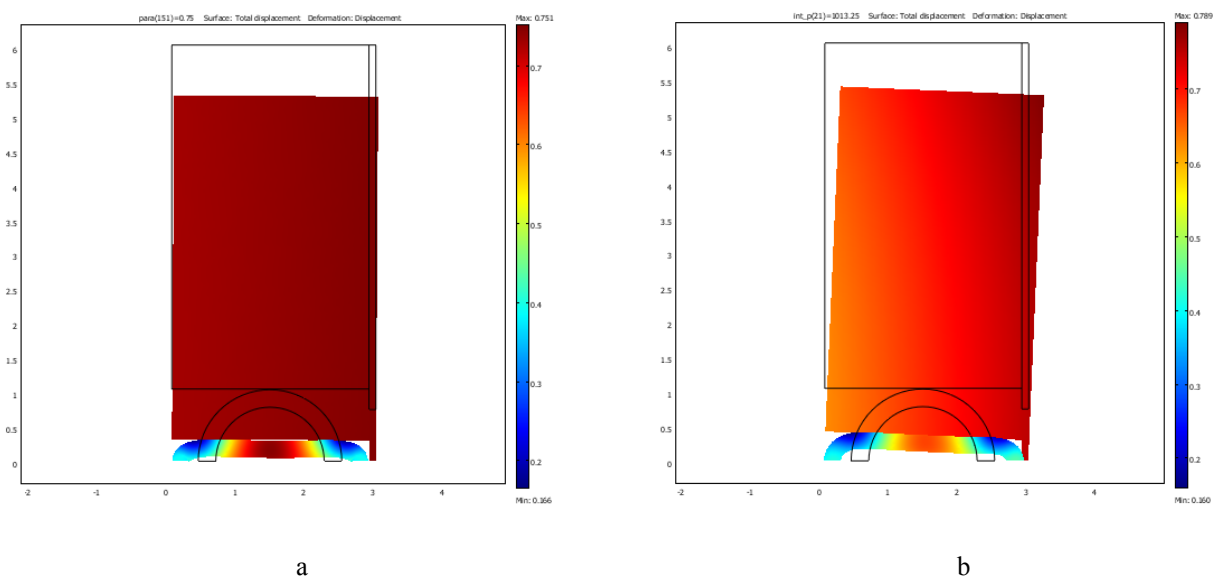

Fig. 5 Resultant displacements of the structural elements: a – after tube insertion process; b – at operation phase

4. Experimental research

The degree to which the system deforms under various pressures within the tubing was measured and compared against results from previous experimentation and finite element analysis. A mechanical pump was used to maintain the pressure at a constant while the results were recorded. The deformation of a single joint (i.e. one tube between two spacers) was recorded as described below. Although the fluidic actuator is suitable for gas or liquid it was decided to carry out pressure testing using liquid, as this fluid best suited the available equipment. As the increase of pressure caused the actuation, thus the particular working fluid type was irrelevant for characterisation.

4.1. Optical test rig

In order to calculate the angle of rotation of a single elastic joint the smart stick was fixed so that only one joint was free to rotate, a mirror was mounted on the front of the spacer. A tube as described earlier was inserted between the free to rotate spacer and a fixed spacer, the pressure in this tube was then controlled via a hand pump that was connected to a pressure sensor. The pressure sensor was attached to a voltmeter to give voltage changes which could then be converted into pressure change. The laser was aimed at the mirror and focused a board covered with graduated paper behind the laser. As the pressure increased the smart stick joint rotated and the position of the laser point moved. The position was recorded at specific voltages. The diagram below (Fig. 6, 7) outlines the rig setup.

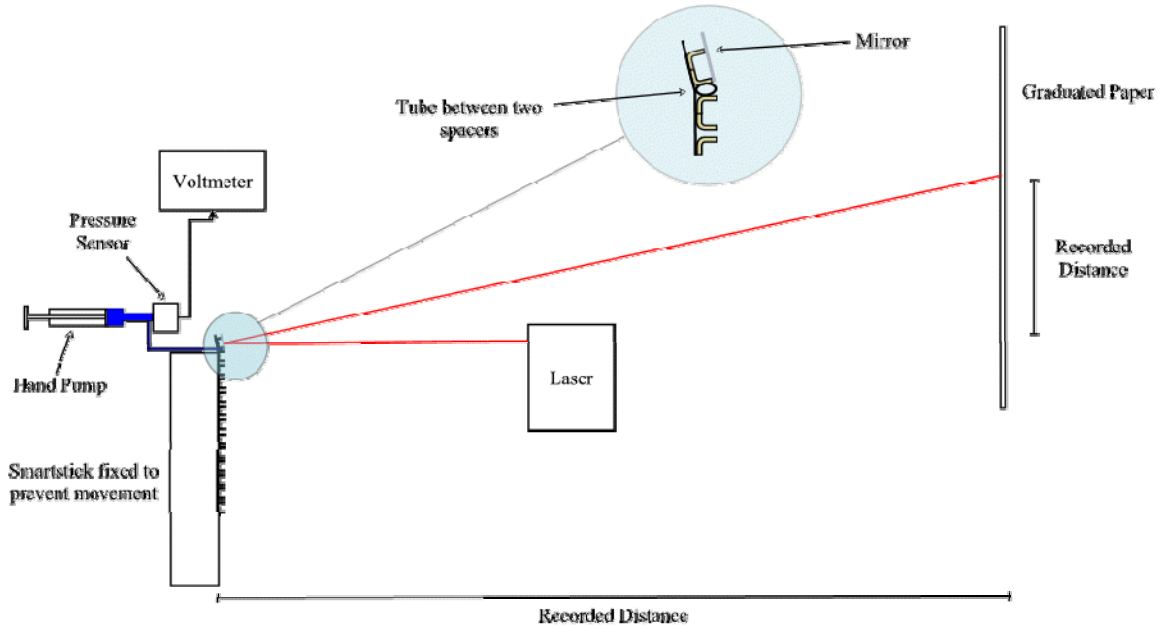

Fig. 6 Rig set up for recording the rotation of a single joint of the Smart Stick

In order to calculate the rotation the law of refraction was applied

$$\theta_i = \theta_r \quad (1)$$

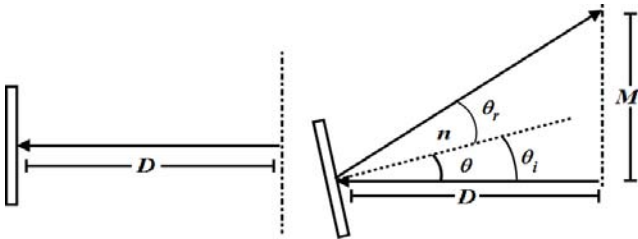

Fig. 7 Calculation of angle of rotation

Where n is perpendicular to the surface, θ_i is the angle to the normal at which the beam hits the reflective surface and θ_r is the angle to the normal at which the beam is reflected.

As a result the angle of rotation can be calculated using the following equation

$$\theta = \frac{1}{2} \arctan\left(\frac{M}{D}\right) \quad (2)$$

But assuming θ is small:

$$\theta \approx \frac{1}{2} \left(\frac{M}{D}\right) \quad (3)$$

To calculating the uncertainty in θ , we require the uncertainty in D and M and using the relationship in [14].

$$D = 6300 \text{ mm} \quad \delta_D = 2 \text{ m}$$

$$M_{max} = 0.445 \text{ mm} \quad \delta_M = 1 \text{ m}$$

$$\delta_\theta = \sqrt{\left[\left(\frac{\partial \theta}{\partial M}\right) \times \delta_M\right]^2 + \left[\left(\frac{\partial \theta}{\partial D}\right) \times \delta_D\right]^2} =$$

$$= \sqrt{\left[\left(\frac{1}{2D}\right) \times \delta_M\right]^2 + \left[\left(-\frac{1}{2D^2}\right) \times \delta_D\right]^2} \quad (4)$$

Numerically

$$i_{c\theta} = \sqrt{\left[\left(\frac{1}{2} \cdot \frac{1}{6.3}\right) \cdot 0.001\right]^2 - \left[\left(\frac{1}{2} \cdot \frac{0.445}{6.8^2}\right) \cdot 0.002\right]^2} \approx 0.00008 \text{ rad} = 0.045^\circ \quad (5)$$

It was assumed that extended uncertainty $i_\theta = \pm 0.125$ degrees and uncertainty in direct measure of pressure $i_p = \pm 0.0025$ MPa is suitable for test rig.

4.2. Experimental results

This is not especially useful for data analysis so consequentially the cycles were averaged, in order to obtain a cycle that could then be assessed. The following graph shows the averaged cycles for the single sided ABS spacer (Fig. 8). The uncertainty in pressure was calculated using [14] as ± 0.002 MPa per reading and the uncertainty in angle was calculated as 0.25° per measurement. These values were constant throughout the experiment and are shown on the graph in the form of error boxes (indicating that the true value lies at some position within these boundaries). It can be seen from this graph that the loading and unloading cycles are different, the loading cycle begins at the zero position however on returning to ambient pressure there is a rotational offset.

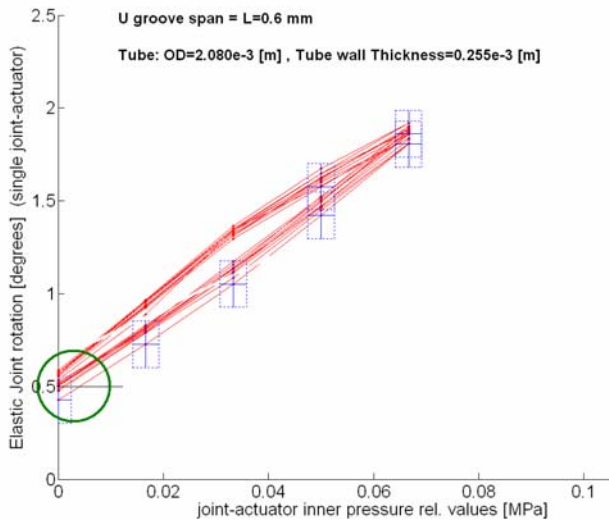

Fig. 8 Angular displacement vs. applied pressure at loading and unloading cycles

5. Results and conclusions

The results of experimental research and simulation were used to obtain performance characteristics of “Smart Stick”. The most important of them “angular displacement vs. applied pressure” is shown in Fig. 9

Sufficient agreement of experimental and simulation results proves the validity of the selected computational model. Sequentially the presented simulation approach can be applied for the investigation of structures of different architectures built on the basics of structural unit (units) the research of which is presented in the paper.

Compliant in its nature foil spacer or U-shaped elements periodic arrangement actuated by a single tube

with no connectors together with active material pressurization block are the basic elements for mechatronic modules development which are embeddable into different structure systems.

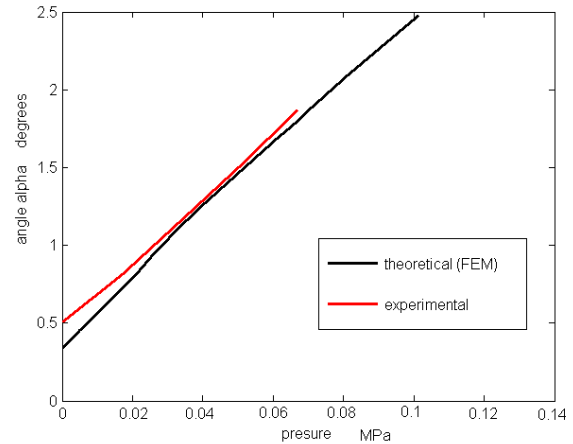

Fig. 9 Angular displacement vs. applied pressure - comparison of experimental and theoretical results

Multimodule realization of “Smart Stick”, with corresponding control unit, is the way to develop multi DOF actuation structures.

References

1. **Barontini, G., Segurini, G., et al.** Building EUROP, the European Robotics Platform. The High Level View, July 2005, Issue 1. -15p.
2. **Berns, K., Ilg, W., Deck, M., Albiez, J., Dillmann, R.** Mechanical construction and computer architecture of the four legged walking machine BISAM. -IEEE Transactions on Mechatronics, 1999, 4(1), p.1-7.
3. **Berns, K., Kepplin, V., Muller, R., Schalenbach, M.** Six-legged robot actuated by fluidic muscles. -In CLAWAR 2000 – Climbing and Walking Robots and the Support Technologies for Mobile Machines, 2000, p.545-550.
4. **Wang, G., Wang, S., Xu, W.** On using Flexure-hinge Five-bar linkages to develop novel walking mechanisms and small scale grippers for microrobots. -Journal of Robotics Systems, 2004, 21(10), p.531-538.
5. **Zhurauski, M.A., Dragašius, E., Korobko, E.V., Novikova, Z.A.** Mechanical properties of smart fluids under combined electrical and magnetic fields. -Mechanika. -Kaunas: Technologija, 2008, Nr.6(74), p.21-24.
6. **Bansevičius, R., Zhurauski, M., Dragašius, E., Chodočinskas, S.** Destruction of chains in magnetorheological fluids by high frequency oscillation. -Mechanika. -Kaunas: Technologija, 2008, Nr.5(73), p.23-26.
7. **Tondu B., Lopez P.** The McKibben muscle and its use in actuating robot arms showing similarities with human arm behavior. -Industrial Robot, 1997, v.24, No.6, p.432-439.
8. **Schulz, S., Pylatiuk, C., Reischl, M., Martin, J., Mikut, R. Bretthauer, G.** A hydraulically driven multifunctional prosthetic hand. -Robotica, 2005, v.23, p.293-299.
9. **Lira, C.,** Variable structure fabric and uses for it. Pat-

- ent Document WO02099172. (2002)
10. **Lira, C., Pilkauskas, K.** Embedded Novel Actuators for Toy Applications.-Proc. 6th International Conference of the European Society for Precision Engineering and Nanotechnology, Baden bei Wien, Austria, 2006, p.228-231.
 11. **Pilkauskas, K., Gaidys, R., Lira, C.** Adaptive structures based on smart stick concept for robotic applications.-Proc. IMAC XXV Conference on Structural Dynamics, Orlando, Florida, February 19-22, 2007, on CD. -7p.
 12. **Lira, C., Scarpa, F.** Adaptive structures for manipulation in clean room.-Proc. SPIE 15th International Symposium on Smart Structures and Materials, San Diego, California. Industrial and Commercial Applications of Smart Structures Technologies, 2008, p.9-13.
 13. **Lira, C., Menon, C., Kianfar, K., Scarpa, F., Mani, M.** Mining smartness from the hydraulic system of spiders: a bioinspired actuator for advanced applications.-Advances in Science and Technology, Trans Tech Publications, 2008, v.58, p.114-119.
 14. **Menon, C., Lira, C.** Active articulation for future space applications inspired by the hydraulic system of spiders. -Institute of Physics Publishing Bioinsp. Biomim, 2006, 1, p.52-61.

K. Pilkauskas, R. Gaidys, C. Lira

„SMART STICK“ ADAPTYVI KONSTRUKCIJA

Re z i u m ė

Straipsnyje nagrinėjama „Smart Stick“ adaptyvi konstrukcija, kurios varančiojo mechanizmo darbo principas paremtas įterptais vamzdelio pavidalo vykdikliais. Šiai mechaninei konstrukcijai būdingas paslankumas, nes ji sudaryta iš tampriaisiais lankstais sujungtų standžių grandžių, tarp kurių įterpiamas tamprus vamzdelis. Darbe modeliuojamas mini vamzdelio įterpimo tarp standžių grandžių, jį tampriai deformuojant, procesas bei jo sąveika su standžia grandimi, kai vamzdelio viduje sukuriama slėgis. Naudojant optinį standą, atliktas eksperimentinis tyrimas, kurio tikslas nustatyti grandies posūkio kampo priklausomybę nuo slėgio. Gauti rezultatai rodo sudaryto skaičiuojamojo modelio adekvatumą nagrinėjamajai konstrukcijai. Tai sudaro prielaidas modeliuoti sistemą esant išorinei apkrovai ir kai slėgiui sukurti naudojamas išorinis šaltinis.

K. Pilkauskas, R. Gaidys, C. Lira

THE SMART STICK ADAPTIVE STRUCTURE

S u m m a r y

This paper describes the smart stick adaptive structure driving mechanism and its operation since the insertion of the tubular actuators. Inserting single tubular element between rigid links, which are elastically hinged, the mechanical structure exhibits compliant nature. The processes of the minitube insertion in between the links elastically deforming it and its interaction with link in contact when pressurized are modelled and simulated. The experimental research conducted using optical test rig with the aim to determine pressure – displacement function of the structure proved the validity of the developed computational model. The fact makes it possible simulation and analysis of further expansion due to the preload of the investigated system using an external source of pressure.

К. Пилкаускас, Р. Гаидис, С. Лира

АДАПТИВНАЯ КОНСТРУКЦИЯ „SMART STICK“

Р е з ю м е

В настоящей работе представлена адаптивная конструкция „Smart Stick“, принцип работы движущего механизма которой основан на применении внедренных трубчатых актуаторов. Исследуемая конструкция эластична так как она состоит из соединенных между собой упругими шарнирами жестких звеньев, между которыми вставляется трубообразный эластичный элемент. В работе представлено моделирование процесса вставления трубообразного элемента между жесткими звеньями упруго деформируя его, а также моделирование процесса взаимодействия последнего с жестким звеном при создании давления внутри трубообразного элемента. С целью установления зависимости между подаваемым давлением и углом поворота жесткого звена проведено экспериментальное исследование конструкции на оптическом стенде. Получены результаты доказывают адекватность составленной модели вычисления исследуемой конструкции. Это создаёт условие для последующего моделирования конструкции, когда применяется внешняя предварительная нагрузка и внешний источник давления.

Received May 25, 2009

Accepted August 21, 2009

DOI: 10.5755/j02.mech.15280