

Arrangement for vertical angle calibration of geodetic instruments

V. Giniotis*, D. Bručas**, L. Šiaudinytė***

*Vilnius Gediminas Technical University, Saulėtekio al. 11, 10223 Vilnius, Lithuania, E-mail: gi@ap.vtu.lt

**Vilnius Gediminas Technical University, Saulėtekio al. 11, 10223 Vilnius, Lithuania, E-mail: domka@ktv.lt

***Vilnius Gediminas Technical University, Saulėtekio al. 11, 10223 Vilnius, Lithuania, E-mail: lauryna@inbox.lt

1. Introduction

Many opto-electronic digital instruments, such as rotary encoders, theodolites, total stations, laser trackers, etc. are used in machine engineering and instrumentation, geodesy, surveying, robotics and other branches of industry. Most of optical - electronic geodetic measuring instruments consist, among the other elements, of the circular scales and angular transducers for angle determination in two perpendicular planes – horizontal and vertical. Accuracy of the instrument mostly depends on the accuracy of these angle measuring instruments. Metrology of the optical instruments for horizontal and vertical angle measurements has some specific features and needs specific arrangements for its calibration, especially this concerns for vertical angle calibration [1, 2]. Here we present a new approach to methodology and means that can be used for the vertical angle calibration of geodetic instruments.

Most of geodetic instruments have two angle reading devices installed – for horizontal and vertical angle measurement. A number of methods of calibration of the horizontal angle measurements are implemented in practice, their origin comes from the circular scales and rotary encoders calibration [3 - 5]. Here we analyse a proposal for arrangement to create the reference standard for angle measurement suitable for vertical angle calibration purposes in laboratory environment. Calibration and testing of the geodetic angle measuring instruments has always been a serious problem and if calibration of the horizontal angle measurements could be quite efficiently accomplished using standard precise turn tables (quite widely implemented in metrology and industry), the calibration of vertical angle measures required some special instrumentation.

Calibration of the accuracy of vertical angle measurements by the geodetic instrument is usually performed using a special test bench composed of autocollimators attached at the different vertical angles to the calibrated instrument (Fig. 1, a). In this case the test bench is extremely bulky and able to measure only very limited number of vertical angles [2, 3]. A new design of the object was implementation of the precise angle encoder as the reference angle standard (Fig. 1, b). In this case it was possible to create unlimited number of reference angle values although the equipment is extremely expensive.

The field testing [1] of accuracy of vertical angle measurement of geodetic instrument is arranged by geometric angle consisting from horizontal and vertical lines previously measured with high accuracy. As they are usually of long distances, it is obvious that assurance of high accuracy of these lines remains a complicated problem both in accuracy and technical aspects. Its use is

not simple and depends on various factors, as temperature changes of environment atmosphere, precipitation, summer or winter atmosphere, etc.

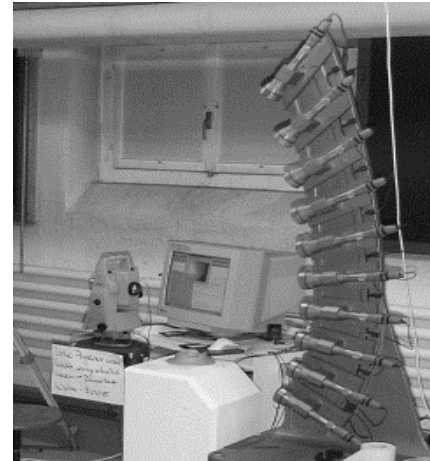

a



b

Fig. 1 Equipment for vertical angle calibration of geodetic measuring instruments: a - implementing a number of autocollimators positioned at certain angle; b - implementing the precision angle encoder

Here we present some development of the new arrangement for vertical angle calibration of geodetic instruments [4 - 6] based on the trigonometric method (angle determination by means of linear measurements) and requires minimal amount of complicated instrumentation.

The reference measure used for the calibration of vertical angle measurement accuracy for machine engineering and geodetic instruments is based mainly on the use of multiangle prism – polygon [4, 7] or precision rotary encoder connected to the axis of the test bench and equipped with an autocollimator placed in front of the axis

of optical tube of the instrument. Such equipment is used at the most famous optical companies producing geodetic instruments with vertical angle measuring facilities. Some inconveniences here also exist, the first one being of very expensive arrangement to be constructed and produced with expensive reference measure used in it. Using the big number of autocollimators also is not convenient, as they

must be placed at different (fixed) angular positions and must be supplied of coaxial attached rotary encoder or polygon for readings to be taken. One of advantages of such arrangement is that the instrument to be checked is pointed to the reticule of the autocollimator, in such way ensuring the strict direction of the instrument's optical axis pointed to the infinity of the autocollimator axis.

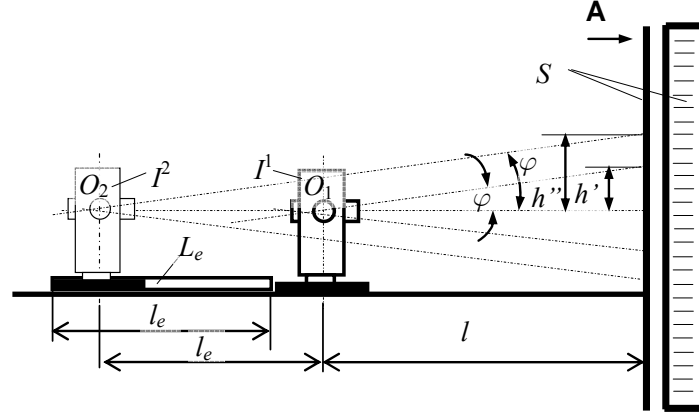

Fig. 2 Arrangement for vertical angle calibration of geodetic instruments

2. Arrangement for vertical angle calibration

The proposed arrangement for vertical angle calibration is based on the trigonometric angle determination using the reference scale of the length for vertical readings by the tacheometer and another reference measure of length – for distance from the tacheometer's axis to the vertical scale determination. The arrangement for calibration is shown in Fig. 2.

The designations in Fig. 2 are: I^1 – initial instrument's position with the axis of rotation of the spyglass O_1 ; I^2 – auxiliary instrument's position with the axis of rotation of the spyglass O_2 . This position is achieved by moving the instrument along the slideways of the test bench for geodetic instruments testing [7, 8]. At the distance l from the axis of the instrument the linear scale S is fixed in vertical position to the instrument's horizontal axis. The distance from the instrument's both positions l_e is fixed by using reference measure of length, for example, end length gauge (length standard). The linear photoelectrical transducer, laser interferometer or even precise linear optical scale (with microscope) can be used for this purpose. It is used for the determination of the distance from the axis of the instrument to the surface of the scale, as it is quite complicated task to do that initially. For the precise vertical angle measurements the distance from instrument to be calibrated (tacheometer) and the reference measure (linear scale) l_m has to be determined quite precisely (down to 0.01 mm) [9-11]. The accuracy of distance determination influences the results of measurements considerably giving a bias of reference data [3].

At the position I^1 of the instrument the reading h' from the scale is taken at the angle ϕ of the axis of telescope of the instrument and horizontal line.

The reading h' from the scale is taken. The angle of interest is expressed

$$\phi = \arctg \frac{h'}{l} \quad (1)$$

After displacement of the instrument linearly to the subsidiary positions I^2 keeping the same vertical angle ϕ , the next reading h'' is taken and the distance l can be determined

$$\phi = \arctg \left(\frac{h''}{l} + l_e \right) \quad (2)$$

and substituting the equations (1) and (2) will yield to

$$l = \frac{h'l_e}{h'' - h'} \quad \text{or} \quad (3)$$

$$l = \frac{l_e}{\frac{h''}{h'} - 1}$$

After taking the readings h' and h'' from the scale S , the true value of the distance l will be determined. Further measurements can be performed determining every tested vertical angle of the instrument operating with known distance and using the readings h_i from the scale. A full range of vertical angles of the geodetic instrument can be tested at laboratory environment in such way improving the accuracy of calibration and with a possibility to perform this at every desired time in spite of meteorological conditions.

3. The experiment

The test of calibration of vertical angle measurements of the geodetic angle measuring instrument (tacheometer) was performed. The calibrated instrument *Trimble 5503* tacheometer with the stated standard deviation of angular measurements of 5" (arc sec) was used.

The arrangement for the experiment was composed according to Fig. 2; the tacheometer was mounted on the linear slideways and aimed to the linear scale posi-

tioned vertically at a distance of approximately 2.5 m for the tacheometer. The industrial laboratory linear scale of high accuracy f 1 m in length with the scale strokes at every 1 mm was used. The linear displacement of the tacheometer to be calibrated was performed using the end length gauge of 200 mm. Optical scale of 1 m in length was used for other tests. After the measurement and calculation of linear distance from tacheometer to the scale performed according to the previous chapter, it was determined that the distance l equals to 2.4215 m.

The main objective of experiment was to test the calibration method and obtain preliminary results of the systematic errors (biases) of the vertical angle measurements using *Trimble 5503* tacheometer.

The calibration was performed using 1 m precise linear scale collimating the spyglass to the scale strokes at a pitch of 10 mm and 12 mm. The resulting calculated deviations of tacheometer readings are shown if Fig. 3 (10 mm pitch) and Fig. 4 (12 mm pitch).

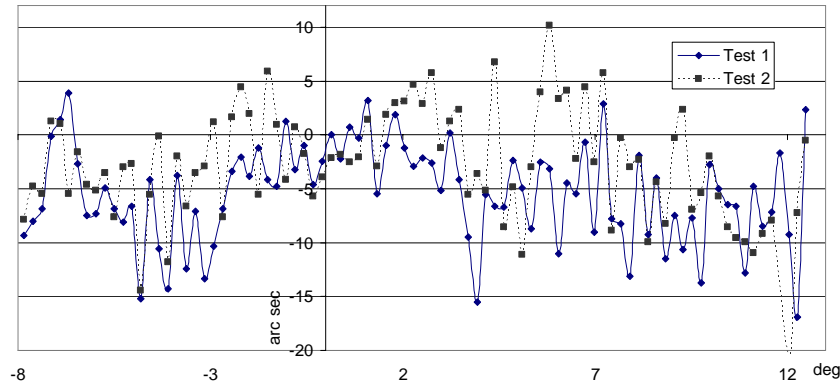

Fig. 3 Deviations of vertical angle readings taken at the linear pitch of 10 mm

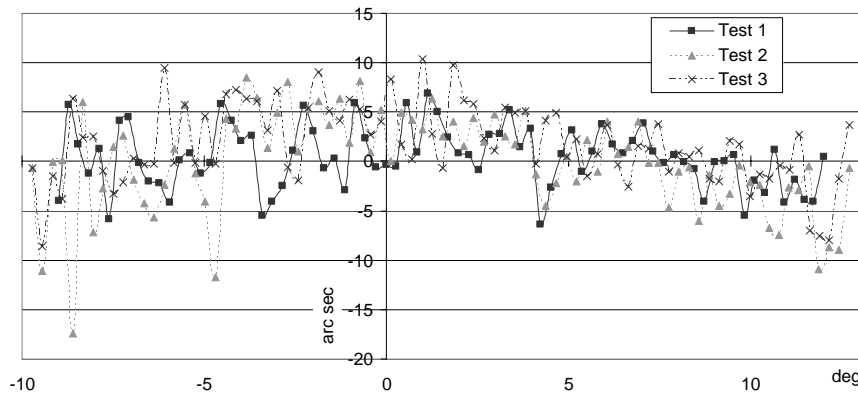

Fig. 4 Deviations of vertical angle readings taken at the linear pitch of 12 mm

Evaluate of the standard deviation of a collimation error (pointing to the scale stroke) is equal to $2.15''$, when the evaluate of general standard deviation of entire measurement procedure is $2.31''$ [9]. Experimental standard deviation [1] of a vertical angle amounts to

$$s_i = \sqrt{\frac{\sum r_i^2}{v_i}} \quad (4)$$

where r_i is the sum of squares of the residuals of the i th series of measurements; v_i is the number of degrees of freedom, which is determined as

$$v_i = (n-1)t$$

where n is sets of vertical angles; t is targets, in our case – the strokes of the reference linear scale.

As can be seen from Fig. 3 and 4, there can hardly be the short period systematic constituent noticed according to deviations (though there should be more measure-

ments performed to finally state that). Still there can be noticed a tendency for decrease of the accuracy towards the limits of the measurements (-10° and 12°), which is quite common for the tacheometers both due to the errors of collimation at steep angles and the principle of action of vertical angle encoder of the tacheometer though more tests should be performed at that item too.

4. Conclusions

1. A simple method of calibration of vertical angle measurements accuracy of geodetic instruments was proposed.
2. Similar method of angle measurement calibration could be implemented for all angle measurements, both vertical and horizontal of collimated instruments such as theodolites, tacheometers, etc.
3. The calibration of accuracy of vertical angle measurement of *Trimble 5503* tacheometer was performed using 1 m precise linear scale positioned at a distance of 2.4215 m to the instrument to be calibrated.
4. Results of the calibration show real biases of

measurement which give an information of the accuracy parameters of the instrument.

Acknowledgments

This work has been funded by the Lithuanian State Science and Studies Foundation, Project B-32/2009.

References

1. **ISO 17123-5:2005.** Optics and optical instruments – Field procedures for testing geodetic and surveying instruments – Part 5: Electronic tacheometers. Geneva: ISO, 2005.-11p.
2. **Walser, B.H.** Development and Calibration of an Image Assisted Total Station: Dissertation.-Zurich: ETH, 2004. -190p.
3. **Ingensand, H.** A new method of theodolite calibration.-XIX International Congress.-Helsinki, Finland, 1990, p.91-100.
4. **Jablonski, R., Shimokohbe, A., Nagai, A.** Calibration system for precision angle standards.-Bull. P.M.E. (T.I.T.), No45, 1980, p.17-24.
5. **Giniotis, V.** Position and Displacement Measurements. -Vilnius: Technika, 2005.-215p. (in Lithuanian).
6. **Cooper, M.A.R.** Modern Theodolites and Levels. Second ed. BSP Professional Books, 1987.-197p.
7. **Giniotis, V., Rybokas, M., Petroškevičius, P.** Investigations into the Accuracy of Angle Calibration. -Geodesy and Cartography, 2004, Nr.3(30), p.65-70.
8. **Bansevičius, R., Giniotis, V., Knight, J.** The application of mechatronics for machines accuracy improvement. -Mechanika. -Kaunas: Technologija, 2001, Nr.3(29), p.44-49.
9. **Bručas, D., Giniotis, V.** Circular scale eccentricity analysis. -Mechanika. -Kaunas: Technologija, 2008, Nr.5(73), p.48-53.
10. **Bručas, D., Sužiedelytė-Vysockienė, J.** Limited accuracy reference free angular position determination. -Mechanika. -Kaunas: Technologija, 2009, Nr.1(75), p.67-72.
11. **Marcinkevičius, A.H.** Automatic control of longitudinal form accuracy of a shaft at grinding. -Mechanika. -Kaunas: Technologija, 2008, Nr.1(69), p.63-68.

V. Giniotis, D. Bručas, L. Šiaudinytė

ĮRENGINYS GEODEZINIŲ PRIETAISŲ VERTIKALIESIEMS KAMPAMS KALIBRUOTI

Резюме

Daugybė optoelektroninių prietaisų, tokių kaip kampo keitikliai, teodolitai, totaliosios stotys ir kt., naudojami mašinų pramonėje bei geodezijoje, robotų technikoje ir kitose pramonės šakose. Daugumą optoelektroninių geodezinių matavimo prietaisų, be kitų elementų, sudaro apskritiminės skalės bei kampo keitikliai, skirti kampinei padėčiai nustatyti dviejose statmenose plokštumose – horizontaliojoje ir vertikaliojoje. Prietaiso tikslumas daugiausia priklauso nuo minėtųjų kampo padėties nustatymo priemo-

nių. Kampo keitiklių, įskaitant ir rastrines skales, metrologija yra gana specifinė ir reikalauja specifinės kalibravimo įrangos. Šiame straipsnyje pateikiama trumpa apžvalga bei kai kurie paprasti būdai ir priemonės, kuriuos galima pritaikyti kampų metrologijai, ypač vertikaliajam plokščiajam kampui kalibruoti.

V. Giniotis, D. Bručas, L. Šiaudinytė

ARRANGEMENT FOR VERTICAL ANGLE CALIBRATION OF GEODETIC INSTRUMENTS

Summary

Many opto-electronic digital instruments, such as rotary encoders, theodolites, total stations, laser trackers, etc. are used in machine engineering and instrumentation, geodesy, surveying, robotics and other branches of industry. Most of optical - electronic geodetic measuring instruments consist, among the other elements, of the circular scales and angular transducers for angle determination in two perpendicular planes – horizontal and vertical. Accuracy of the instrument mostly depends on the accuracy of these means for angle measurement. Metrology of the angular transducers including the raster scales has some specific features and needs the specific arrangements for its calibration. Here we present a review and some simple means and methods that can be used in the angle measurement metrology, especially for vertical plane angle calibration.

В. Гиниотис, Д. Бручас, Л. Шяудините

УСТРОЙСТВО ДЛЯ КАЛИБРОВАНИЯ ВЕРИКАЛЬНОГО УГЛА ГЕОДЕЗИЧЕСКИХ ИНСТРУМЕНТОВ

Резюме

Многие оптоэлектронные цифровые измерительные инструменты, такие как угловые преобразователи, теодолиты, тотальные станции, лазерные трекеры и т. п., применяются в машиностроении, геодезии, робототехнике и прочих отраслях промышленности. Многие из оптоэлектронных геодезических измерительных инструментов, содержат круговые шкалы и угловые преобразователи для определения углов в двух перпендикулярных плоскостях – горизонтальной и вертикальной. Точность инструмента в основном зависит от точности этих угломерных приспособлений. Метрология угловых преобразователей, включая растровые шкалы, довольно специфическая и требует специфических приспособлений для калибрования. В данной статье представлен обзор и рассмотрены некоторые простые способы и приспособления, которые могут использоваться в метрологии углов, в частности, для калибрования вертикального плоского угла.

Received July 24, 2009

Accepted September 30, 2009

DOI: 10.5755/j02.mech.15491