

Parametric analysis of hermetic refrigeration compressors

V. Dagilis*, L. Vaitkus**

*Kaunas University of Technology, K. Donelaicio g., 44239 Kaunas, Lithuania, E-mail: vytautas.dagilis@ktu.lt

**Kaunas University of Technology, K. Donelaicio g., 44239 Kaunas, Lithuania, E-mail: liutauras.vaitkus@ktu.lt

1. Introduction

J. Rigola and C.D. Perez-Segarra propose several comprehensive works [1-5] focused on presenting different parametric studies of hermetic reciprocating compressors, based on the numerical simulation model developed. Results presented show the influence of different aspects such as main geometry parameters, valves characteristics, working conditions, motor efficiency, etc. on the compressor volumetric efficiency and coefficient of performance. However, there are no investigations either on the interdependency of different factors impacting the efficiency of compressors or losses of friction.

Relevance of friction and wear to environment impact represented in [6, 7] is of particular importance in achieving the requirements of Kyoto Protocol. There are same studies [8-11] providing an experimental material related to the evaluation of friction losses in pairs that work most severely. The calculations of indicated losses in the valves were presented in [12-14]. The calculations were based on some experimentally determined relationships such as flow force coefficient and flow rate coefficient. The simulation of valve performance and calculation of indicated power were presented in [14, 15].

The authors of this article in their previous works [16-21] have described the mathematical model of complete compressor, taking into account also friction forces. The articles also give analysis of friction forces. Validation of simulation results together with comparison of theoretical and experimental results is given in [17, 20]. The satisfactory agreement was obtained.

Energy consumption for vapour compression was determined through mathematical modelling and estimated using known relationships from [12, 23-25]. Since this consumption is the main component, the special attention was taken for accuracy estimation and analysis.

The articles [17, 20] give calculations of all three components of energy consumption (energy consumption for vapour compression, indicated losses and friction losses). Separated measurement of every component is hardly possible – only their sum may be measured. Measured energy consumption of these components and angular velocity was in good agreement with simulated results [20]. However, some doubts considering accuracy of the simulation still existed. The errors of calculation may still be high if they mutually compensates.

In this article the estimation and analysis of energy consumption components for particular hermetic compressor is given. For experimental investigation and analysis the slider-link driven compressor with the volume of 8.60 cm³ was chosen (piston's diameter 24 mm, stroke 19 mm). At ASHRAE conditions the average compressors capacity was 148.6 W, power consumption was 104.7 W and efficiency or COP was 1.42.

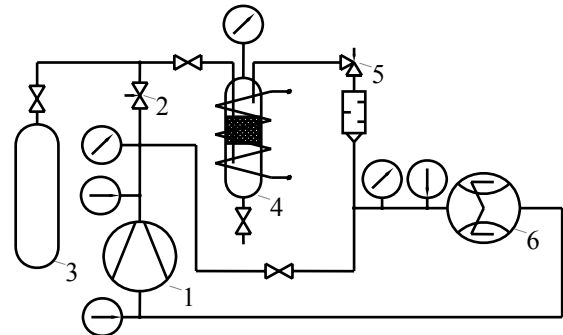

Fig. 1 Calorimetric test-rig; 1 – compressor, 2 – discharge pressure regulating valve, 3 – receiver, 4 – intermediate pressure receiver with heater and oil separator, 5 – suction pressure regulator, 6 – flow meter

A refrigerating compressor calorimetric test-rig (Fig. 1) was designed and manufactured in order to investigate compressors by determining not only refrigerating capacity and coefficient of performance, but also friction losses, efficiency of electric motor, amount of the discharged oil and suction pressure drop. The test-rig allows determining characteristics of the compressor sufficiently quickly providing the possibility to record data from the very beginning of the testing. A little thermal inertia of testing is achieved by avoiding processes of condensation and evaporation during the working cycle. The capacity of compressor is estimated by determining flow of refrigerant through the flowmeter. Special valves maintain pressures at the suction and discharge sides. Inside the main part of the test-rig some intermediate pressure is maintained; there gas condensation does not occur, and oil can be separated from refrigerant quite easily. The possibility to vary pressures during a test allows obtaining data very quickly. When the pressure difference between condensation and evaporation is lower, maintaining suction pressure at high accuracy is much easier. In this case, the suction pressure is maintained not from condensation pressure but from some intermediate pressure. The accuracy of test-rig is high enough and error does not exceed 1%.

2. Cycle energy consumption estimation and analysis

Compressor's energy consumption for working cycle consists of energy used for vapour compression and energy used for suction / discharge through valves (indicated losses).

There are a few ways to find the cycle energy consumption. The most accurate way would be the integration of real diagram of compressor's cycle. However, getting such diagram is difficult.

The second way is theoretical simulation. The pressure in the cylinder is obtained numerically solving differential pressure change equations. The accuracy of

such method depends on how detailed all four processes (compression, discharge, expansion of dead volume and suction) are simulated. For example, the simulation may be done taking into account movement of the valves and / or taking into account blow – by losses through the clearance between the cylinder and the piston. The problems were analysed by the authors in [13, 14].

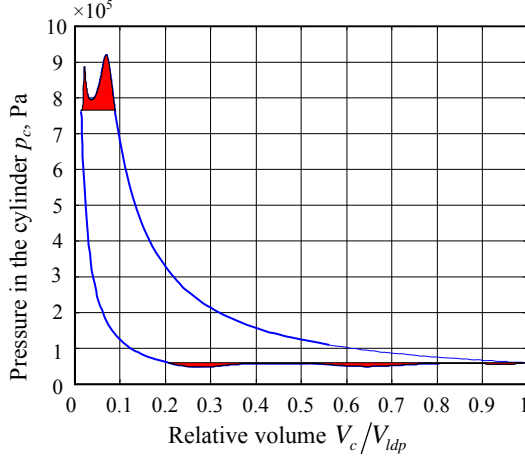

Energy consumption for vapour compression, W	70.20
Energy returned from expanding dead volume, W	13.29
Energy consumption for suction, W	1.62
Energy consumption for discharge, W	2.39
Indicated losses, W	3.93
Energy consumption for the whole cycle, W	60.86

Fig. 2 Indicated diagram, obtained for analysed compressor at ASHRAE conditions [15]

The theoretical simulation of compressor's cycle was presented in previous works of the authors [13-15]. It was based on theory and experimental relationships of the valve's flow rate coefficient [13], flow force coefficient [14], semi-empirical relationship for the calculation of blow-by losses through the clearance between the piston and the cylinder. The detailed model of valve's dynamics was presented in doctoral thesis [15]. The Fig. 2 gives indicated diagram obtained for analysed compressor working with R600a at ASHRAE test conditions.

The third way is related to theoretical equation of adiabatic process, which is modified to take into account the decrease of vapour density in a suction process. The vapour density in a suction process decreases because of pressure losses in a suction muffle and the valve.

The obtained cycle diagram qualitatively is very close to the diagrams, presented by other authors in [1, 3, 4, 12]. At the same conditions the discharge valve makes two moves, and does not reach the seat at the first move back. Also it could be admitted that less energy is consumed for suction than for discharge, in spite of the fact, that the suction valve makes more moves. For the analysed compressor the simulation results are given on Fig. 2.

The Fig. 3 gives cycle diagrams at three different condensing pressures. One of the diagrams is for condensing pressure at 55°C which correspond to compressors test conditions (at CECOMAF conditions). At lower condensing temperature relative energy consumption increases; especially increase the discharge valves indicated losses. If at 55°C condensing temperature they make 3.7% from consumption for the whole cycle, at 45 and 35°C they increase to 4.8% and 6.0% correspondingly. The Fig. 4 gives

relationship of indicated losses subject to operation conditions of the compressor. These relationships were obtained using the mathematical modelling for the specific valves. The geometrical and physical properties of the valves (mass distribution, stiffness etc.) were determined experimentally and presented in the work [15]. The chart was obtained for the specific valve, but it displays the relative value of indicated losses and their change at various operating conditions.

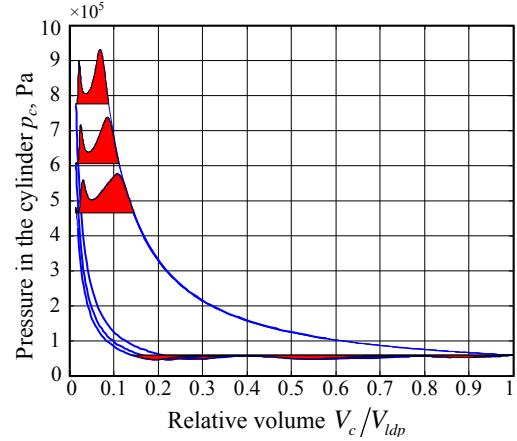

	$t_c = 55^\circ\text{C}$	45°C	35°C
Consumption for vapour compression, W	70.9	63.0	55.0
Returned from expanding dead volume, W	13.57	9.50	3.40
Consumption for suction, W	1.610	1.706	1.745
Consumption for discharge, W	2.29	2.76	3.42
Indicated losses, W	3.90	4.47	5.17
Consumption for the whole cycle, W	61.2	57.9	56.8

Fig. 3 Indicated diagram at various condensing temperatures: a - $t_k = 55^\circ\text{C}$; b - $t_k = 45^\circ\text{C}$; c - $t_k = 35^\circ\text{C}$

Compressor's cycle energy consumption can be calculated by the equation of isentropic compression. However, the specific heat ratio k and polytropic exponent for expansion process m for real processes should be used. One should also take into account that vapours pressure before the compressor shell is higher than the pressure in the cylinder at the beginning of compression process. It is higher by the value Δp_s which is pressure losses on the suction side (at the entrance of compressor's shell, in suction muffle and through suction valve).

The equation is given in [24]

$$W = p_1 V_h \left\{ (1+c) \frac{k}{k-1} \left[\left(\frac{p_2}{p_1} \right)^{\frac{k-1}{k}} - 1 \right] - \frac{cm}{m-1} \left[\left(\frac{p_2}{p_1} \right) - \left(\frac{p_2}{p_1} \right)^{\frac{1}{m}} \right] \right\} \quad (1)$$

where $p_1 = p_s - \Delta p_s$ and $p_2 = p_d$ is pressure in the cylinder at the beginning of compression and at the end of compression correspondingly; $V_h = (\pi D^2/4) S n$ is the piston displacement ($V_h = 0.000418 \text{ m}^3/\text{s}$); D is the cylinder diameter; S is the stroke; n is rotation speed of crankshaft; k and m are correspondingly polytropic exponent for compression process and expansion process; c is relative dead volume ($c = 0.018$ [15]). Pressure at the end of compression p_d here is equal to condensing pressure, since the equation does not take into account the indicated losses.

If polytropic exponents for compression and expansion processes are assumed equal to specific heat ratio $n_c \cong n_e \cong k$, the Eq. (1) can be simplified

$$W = (p_s - \Delta p_s) V_h \theta \frac{k}{k-1} \left[\left(p_d / (p_s - \Delta p_s) \right)^{\frac{k-1}{k}} - 1 \right] \quad (2)$$

here θ is coefficient, evaluating energy returned by the expanding gas from the dead volume. It can be calculated according to the following equation

$$\theta = 1 - c \left[\left(p_d / (p_s - \Delta p_s) \right)^{\frac{1}{m}} - 1 \right] \quad (3)$$

During the calorimetric test we can determine the total volumetric losses, which are made of losses because of dead volume, losses because of gas heating, blow-by losses and volumetric losses because of pressure drop on suction side Δp_s .

To determine Δp_s we have to find other volumetric losses or measure Δp_s in such a way, that other volumetric losses would be equal to zero. With the mentioned test-rig it is possible to measure Δp_s . This is done measuring volumetric capacity of idle running compressor. Compressor's suction and discharge is connected to the same receiver and volumetric capacity is measured. Since the vapour is not compressed, the losses because of the dead volume or blow-by losses are very small and may be neglected. Losses because of vapour heating may be eliminated by measuring for a short period immediately after the compressors start. The measured cylinder's temperature of idle-running compressor through the first 10 minutes increases by the 15°C, and through the first minute only by 2.5°C. We did our measurements 30 seconds after the start, when the flow is already steady, but the temperature is low and volumetric losses due to vapour heating did not exceed 0.5%. Since the pressure ratio for idle-running compressor is just 1.4, volumetric losses because of dead volume also are small and do not exceed 0.8%. At such conditions estimated volumetric losses were 9.5%. After subtracting 0.8% for dead volume and 0.7% for vapour heating, the losses Δp_s are 8.0%. Thus $p_s = 0.92 \times p_o = 0.581$ bar where p_o is evaporation pressure.

In Eq. (1) the big influence has specific heat ratio k and polytropic exponent m . Usually the specific heat ratio, given in manuals for isobutane is $k = 1.1$. This value is close to actual value at suction conditions - $k = 1.098$. However, when temperature increases the k value decreases. A real vapour temperature in the cylinder is about 80°C (at the end of suction process). Temperature at the end of the suction (or at the beginning of the compression) is assumed according to experimental measurements. Measurement of this temperature is complicated, but the temperature of vapour before it enters the cylinder was measured during the calorimetric tests. This temperature at ASHRAE test conditions was 76°C. According to works [22, 25] the temperature increase from the walls of the cylinder was preliminary assumed equal to 4°C. In such case enthalpy of the vapour before it enters the cylinder is $h_1' = 692.5$ kJ/kg and at the beginning of compression the

temperature is 80°C and specific heat ratio k of isobutane is 1.083. At the end of compression process the temperature further increases and k value decreases.

The Eq. (1) is based on ideal gas model. In order to decrease inaccuracy of calculation according the Eq. (1) such k value should be found, which at the end of compression gives the same temperature and enthalpy as obtained from the diagram. For example, according to the reference information after the isentropic compression from the state of 80°C and 0.585 bar to 7.702 bar the vapour temperature is 152°C and enthalpy is $h_2 = 839.4$ kJ/kg. If temperature is calculated according to adiabatic process equation $T_2 = T_1 \left[p_d / (p_s - \Delta p_s) \right]^{(k-1)/k}$, using average k value for such compression process ($k = 1.087$), calculated temperature at the end of compression process is $T_2 = 160.5$ °C and enthalpy is $h_2 = 859.4$ kJ/kg. Compression work in such case is major by 14%. Using k value at the average temperature ($k = 1.081$), the calculated temperature at the end of compression process is $T_2 = 155.3$ °C. So, in our opinion the value of k should be calculated from the condition that temperature at the end of compression is $T_2 = 152$ °C. In such case $k = 1.078$.

The expansion from the dead volume significantly decreases cycle's energy consumption. The amount of returned work is determined by the polytropic exponent of expansion process m . Often it is assumed that $m = k$, but such assumption is not accurate. In [24] for the gas with p_s below 1.5 bar the relation $m = 1 + 0.5(k - 1)$ is given. In such case for $k = 1.078$ the polytropic exponent of expansion process is $m = 1.039$.

Energy consumption for vapour compression calculated according to Eq. (1) is equal to 70.32 W, and energy return from expanding dead volume is 13.60 W. Then compressor's cycle energy consumption is $W_{iso} = 56.72$ W. This value coincides with the results obtained by the means of mathematical modelling. Taking into account calculated indicated losses (Fig. 4) the energy consumption for the whole cycle is 60.52 W.

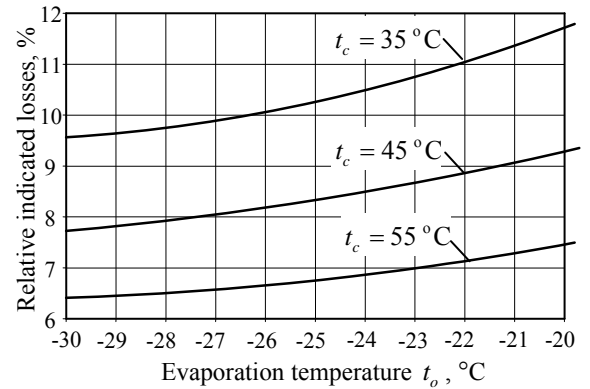

Fig. 4 Relative indicated losses subject to evaporation temperature t_o and condensing temperature t_c

Energy consumption for the whole cycle can also be calculated according to equation $W = g(h_1' - h_2)$ where h_1' and h_2 are enthalpies of vapour correspondingly before

entering the cylinder and after the discharge valve. Enthalpy after the discharge valve in this case is $h_2 = 839.8$ kJ/kg. The enthalpy h_1 is taken according to experimentally determined temperature 76°C , thus $h_1 = 692.5$ kJ/kg. In the equation the term g is compressor's mass flow, which for the ASHRAE test conditions and for 148.6 W cold capacity is equal to 0.000441 kg/s. Then energy consumption is $W = 65.96$ W. Adding the same indicated losses (according to the Fig. 4) and distracting energy returned from expanding of the dead volume (13.6 W) we get 56.78 W. Thus, all three methods give similar value of energy consumption for the whole cycle.

Therefore we can state, that compressor's energy consumption for vapour compression cycle may be estimated with reasonable accuracy. This accuracy is also confirmed by the parametrical analysis. The value of the compressor's input power obtained after estimation of friction losses and electrical losses is close to the value determined experimentally during the calorimetric test, i.e. 104.7 W.

3. Evaluation of friction and electrical losses

Calculation of the compressor's friction losses is quite complicated. Friction pairs are working at the boundary or the mixed lubrication conditions [9]. This is not only caused by high loads, but also by the fact that moving parts in the friction pairs are almost always misaligned. Mathematical modelling of the friction pairs under such conditions requires experimentally determining or assuming friction coefficients. Experimental validation of friction losses calculation is complicated as well since during the calorimetric test the friction losses can not be directly measured. All components of total input power may be evaluated through experimental and analytical methods. For example, electrical losses of specific motor may be found experimentally. Fig. 5 gives measured parameters of electric motor for the investigated compressor.

Mathematical modelling and analysis of friction losses was presented by the authors in their previous works [16-20]. In the works the CKH-130H5 compressor („ATLANT“, Byelorussia) with displacement of 9.55 cm³ (piston's diameter 26 mm, stroke 18 mm) was analysed. In this article we analyse compressor with the displacement of 8.6 cm³ (piston's diameter 24 mm, stroke 19 mm). It was selected due to big amount of available experimental data, including measurements of friction losses

For calculating friction losses the friction coefficients μ are required. The authors in their previous works [16, 17] presented a mathematical model of compressor and considered the methods for determining friction coefficients. The model allows calculating all the reactions, friction and inertia forces subject to rotation angle. The model was used for the calculation of the forces and friction losses for the investigated compressor with the displacement of 8.6 cm³.

Fig. 6 gives reactions exerted on piston for one revolution of crankshaft. As can be seen, the forces F_{GN1} and F_{GN2} during the revolution change their direction four times. The directions of the forces mostly depend on the position of reaction F_{BN} relatively to the cylinders (pistons) axis. The reaction point of the force F_{BN} during one

revolution passes through the axis twice – at the end of compression and at the end of suction. The third direction change of F_{GN1} and F_{GN2} forces occurs at the end of gas expansion from the dead volume. The last direction change is related to the change of direction of the piston's and slider's inertia forces in suction process. The slider – link driven compressors have heavy pistons and sliders, therefore the inertia forces have a big influence. The inertia force also causes the direction change of the main force F_{BN} in the middle of suction process.

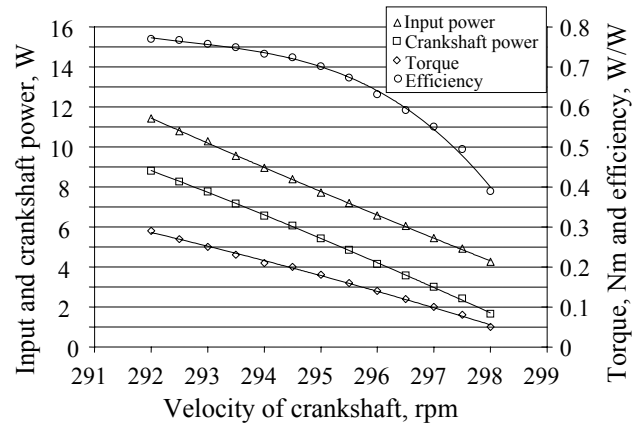

Fig. 5 Measured characteristics of electrical motor

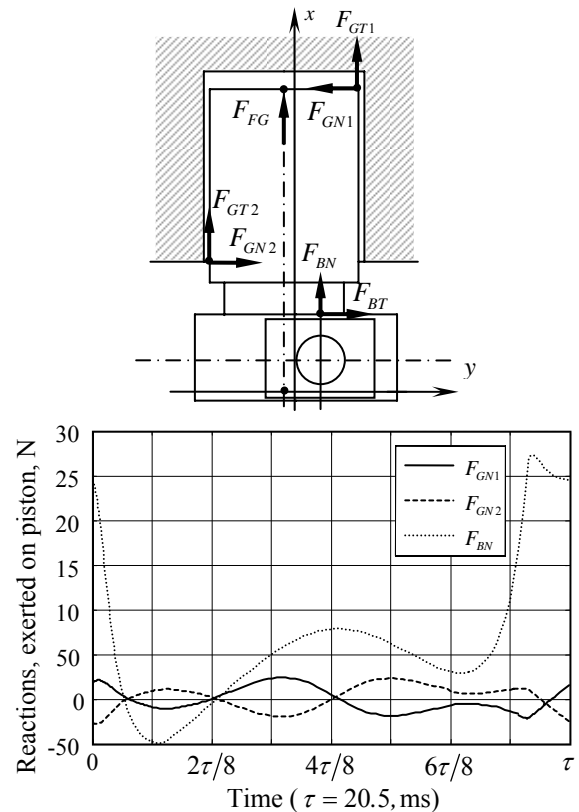

Fig. 6 Diagram of piston with exerted reactions (on the top) and calculated reactions for one revolution

Fig. 7 gives friction forces exerted on the piston including the force of viscous friction between the piston and the cylinder F_{FG} . This force is big because of small clearance between the piston and the cylinder. On the other hand, the friction force F_{FG} is decreased since the viscosity of oil in the clearance is lower than the viscosity in other friction pairs due to high temperature and big amount

of solved refrigerant. The biggest friction force F_{BT} occurs between the link and the slider. This force changes its direction twice due to changed direction of sliders velocity. The Fig. 8 gives the friction power of piston forces.

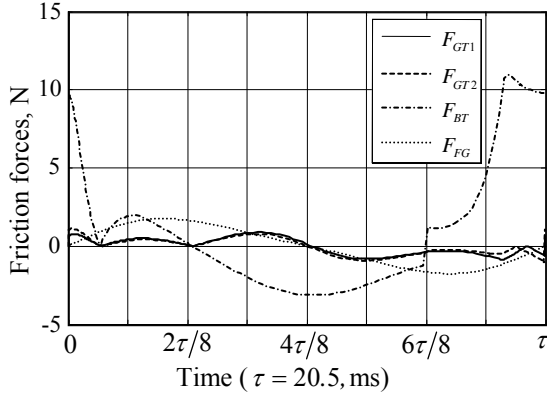

Fig. 7 Friction forces exerted on the piston

Other two figures Figs. 9 and 10 display the loads of the bearings and corresponding friction moments. Three main reactions are exerted on the crankshaft. The reaction F_k is exerted on crankpin from the side of the slider and is related to piston forces. Other two forces F_a and F_b are reactions of upper and lower bearings. As it can be seen, the highest load F_a is exerted on the upper bearing, and the sum of the other two reactions is approximately equal to F_a .

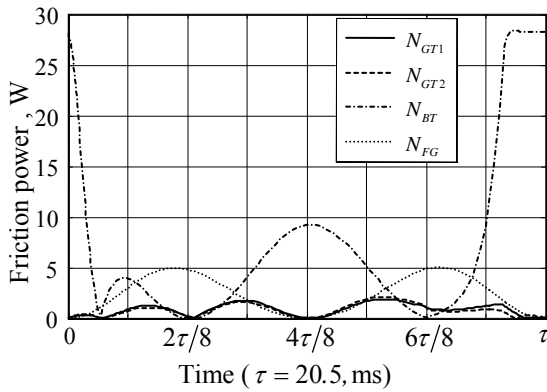

Fig. 8 Friction power of piston forces

Average friction losses for every friction pair (W) are used not only for the calculation of total friction losses, but also for qualitative analysis (Table).

Table

Average (integral) friction losses for friction pairs (W)

N_{GT1}	N_{GT2}	N_{FG}	N_{BT}	N_{MR}	N_{MS}	N_{MK}	N_{MZ}
0.895	0.839	2.42	7.02	1.55	1.49	1.40	1.47

The biggest friction losses are in slider – link friction pair – 7.02 W. Their deeper analysis can be done using Fig. 7. The change of these losses during one revolution explains why they are the biggest: when friction force F_{BT} is the biggest, the sliding velocity in corresponding friction pair is also the biggest. At this moment the end of compression, discharge processes and beginning of expansion of the dead volume occurs. However, this does not mean

that friction losses of slider – link driven compressor exceed these of a connected rod driven compressor. A connecting rod driven compressor has significantly higher friction losses in the connecting rod – crankpin friction pair due to higher sliding velocity in this pair. If for analysed

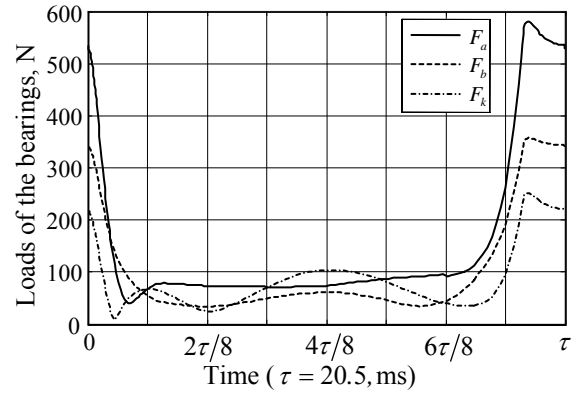
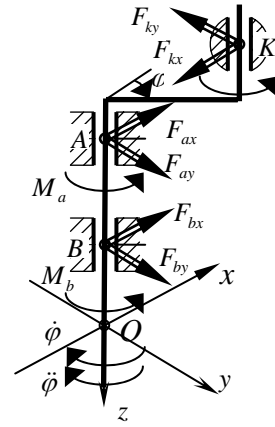

Fig. 9 Diagram of crankshaft under load (on the top) and calculated loads of the bearings for one revolution

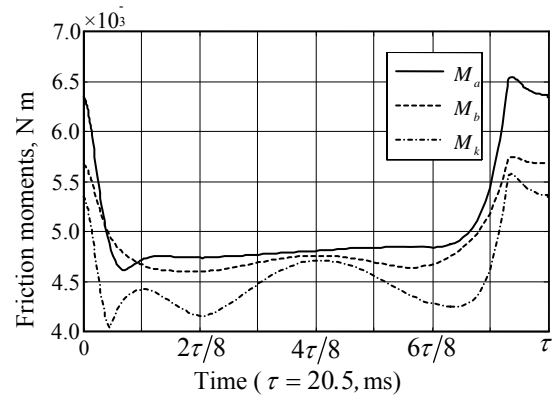

Fig. 10 Friction moments of the bearings

compressor $N_{MK} = 1.40$ W, for connecting rod driven compressor it would be almost 3 W. In addition to that the connecting rod driven compressors have gudgeon-pin friction pair which is friction pair under the heaviest load conditions in the compressor. The laboratory tests show that in this case the difference of friction losses between the slider-link driven and connecting rod driven compressors is about 2 - 2.5 W (tests were done with RL10H oil).

4. Analysis and conclusions

Efficiency of the hermetic refrigerating compressor strongly depends on its energy consumption, which

does consist of three main components. The biggest component is energy consumption in vapour compression cycle, which on its own is made of energy used for compression, indicated losses and energy returned from expanding dead volume. Other two components are related to losses – friction losses in the compressors friction pairs and electrical losses in the motor. The efficiency of the compressor is evaluated through measurement of its input power, which is the sum of all mentioned components. Experimental determination of each component separately from the others is complicated. Only the motor's electrical losses may be determined experimentally.

The presented comprehensive analysis of the compressors working cycle shows that energy consumption may be accurately determined by the means of mathematical modelling if vapour temperature and pressure before it enters the cylinder is known. The article gives simulation results for the specific compressor, for which valve characteristics, pressure losses on the suction side and dead volume was determined experimentally. The analysis of cycle shows that specific heat ratio of refrigerant k should be calculated from the condition that temperature at the end of compression should be equal to its actual temperature. At such conditions the results of mathematical modelling are reasonably accurate. They were compared to the results, calculated according to classical equations and reasonable agreement was obtained.

The article also gives estimated friction losses of the analyzed compressor, obtained through the use of mathematical modelling. The mathematical model itself and details of simulation were presented in previous works of the authors. The simulation results of friction losses in various friction pairs, presented here, allow deeper analysis of the losses and points out the ways and means for their decrease.

Energy consumption for vapour compression cycle was evaluated according to two methods (the obtained results are 60.9 W, 60.52 W and 56.78 W). Its sum with friction losses (17.1 W) gives reasonable agreement with crankshaft power of the motor (80.1 W), when the input power of the motor is 104.7 W. Such input power of the compressor was experimentally determined at ASHRAE test conditions.

It's clear, that most accurate parametric analysis can be done through the thorough mathematical modelling and simulation. However, the mathematical model required for this should include simulation of working cycle taking into account valve dynamics, blow-by losses and heat exchange as well as compressors dynamics simulation taking into account friction losses. Such mathematical model is a powerful tool, but its development and validation is complicated and time consuming.

However, sometimes it would be very interesting to have equipment and test procedure allowing "express" parametric analysis. The results could not be so accurate, but analysis could be done in a few hours. We believe that presented parametric analysis and test rig is a step in that direction. The test procedure could be as following:

- testing of idle running cold compressor to determine losses due to pressure drop;
- testing of idle running hot compressor to determine losses due to gas heating;
- calorimetric test to determine cold capacity and

total power consumption;

- calculation of cycle power consumption. Here we believe the k value should be calculated from the condition that temperature at the end of compression should be equal to actual temperature;
- measuring parameters of electrical motor;
- friction losses then may be estimated through subtracting electrical losses and cycle energy consumption from total energy consumption.

Accuracy of such procedure may be further improved using more advanced mathematical model of compressor valves. This would allow more thorough validation of the steps 1, 2 and 4.

References

1. **Rigola, J., Perez-Segarra, C.D., Oliva, A.** Parametric studies on hermetic reciprocating compressors. -International Journal of Refrigeration, 2005, 28, p.253-266.
2. **Perez-Segarra, C.D., Escanes, F., Oliva, A.** Numerical study of the thermal and fluid dynamic behaviour of reciprocating compressors. -Proceedings of the International Compressor Engineering Conference.-Purdue University, IN, USA, 1994, p.145-150.
3. **Perez-Segarra, C.D., Rigola, J., Oliva, A.** Modelling and numerical simulation of the thermal and fluid dynamic behaviour of hermetic reciprocating compressors. Part 1: Theoretical basis.-Int. J. Heat Ventilation Air Conditioning Refrig. Res., 2003, 9(2), p.215-236.
4. **Rigola, J., Perez-Segarra, C.D., Oliva, A.** Modelling and numerical simulation of the thermal and fluid dynamic behaviour of hermetic reciprocating compressors. Part 1: Experimental investigation. -Int. J. Heat Ventilation Air Conditioning Refrig. Res., 2003, 9(2), p.237-249.
5. **Rigola, J., Raush, G., Perez-Segarra, C.D., Oliva, A.** Detailed experimental validation of the thermal and fluid dynamic behaviour of hermetic reciprocating compressors. -Int. J. Heat Ventilation Air Conditioning Refrig. Res., 2004, 10(3), p.91-306.
6. **Garland, N.P., Hadfield, M.** Environmental implications of hydrocarbon refrigerants applied to the hermetic compressor. -Materials and Design, 2005, 26, p.576-586.
7. **Granryd, E.** Hydrocarbons as refrigerants. -Int. J. Refrig, 2000, No24, p.15-24.
8. **Safari, S., Hadfield, M.** Wear behavior of the gudgeon pin in hermetic compressor with replacement CFC refrigerant. -Wear, 1998, 219, p.8-15.
9. **Ciantar, C., Hadfield, M., Smith, A.M., Swallow, A.** The influence of lubricant viscosity on the wear of hermetic compressor components in HFC-134a environments. -Wear, 1999, 236, p. 1-8
10. **Nautiyal, P.C., Schey, J.A.** Transfer of aluminum to steel in sliding contact: effects of lubricant. -ASME Journal of Tribology, 1990, 112, p. 282-287.
11. **Vekteris, V., Čereška, A., Jurevičius, M., Striška, V.** Experimental research of rotor axis revolution orbit in rotor systems with adaptive and sleeve sliding-friction bearings. -Mechanika. -Kaunas: Technologija, 2008, Nr. 2(70), p.38-43.
12. **Longo, G.A., Gasparella, A.** Unsteady state analysis

of the compression cycle of a hermetic reciprocating compressor. -International Journal of Refrigeration, 2003, 26, p.681-689.

13. **Dagilis, V., Vaitkus, L., Kireichick, D.** Flapper –type valve’s flow rate coefficient and it’s influence on pressure losses. -Mechanika. -Kaunas: Technologija, 1998, Nr.1(12), p.28-35 [in Lithuanian].
14. **Dagilis, V., Vaitkus, L.** Experimental research of flapper type valve’s flow force coefficient. -Mechanika. -Kaunas: Technologija, 1998, Nr.4(15), p.40-45 [in Lithuanian].
15. **Vaitkus, L.** Research and Simulation of Valve System of Hermetic Refrigerating Compressor. Doctoral thesis. -Kaunas, 1998.-108p.
16. **Dagilis, V., Vaitkus, L., Kirejchick, D.** Slider-link driven compressor (I). Mathematical model. -Mechanika.-Kaunas: Technologija, 2006, Nr.6(62), p.25-31.
17. **Dagilis, V., Vaitkus, L., Kirejchick, D.** Slider-link driven compressor (II). Simulation results. -Mechanika. -Kaunas: Technologija, 2007, Nr.1(63), p.50-57.
18. **Dagilis, V., Vaitkus, L., Balčius, A., Kirejchick, D.** Slider-link driven compressor (III). Optimization. -Mechanika. -Kaunas: Technologija, 2007, Nr.3(65), p.46-50.
19. **Dagilis, V., Vaitkus, L., Kirejchick, D.** Mathematical model of slider-link driven compressor (I). -Compressors 2006: proceedings. -Bratislava: International Institute of Refrigeration, 2006, p.110-118.
20. **Dagilis, V., Vaitkus, L., Kirejchick, D.** Mathematical model of slider-link driven compressor (II). Simulation results. -Compressors 2006: proceedings. -Bratislava: International Institute of Refrigeration, 2006, p.119-127.
21. **Dagilis, V., Vaitkus, L.** Losses because of the leak in the compressors, operating with environmentally friendly refrigerants. -Mechanika. -Kaunas: Technologija, 1997, Nr.3(10), p.26-33 [in Lithuanian].
22. **Porkhial, S., Khastoo, B., Modarres Razavi, M.R.** Transient characteristic of reciprocating compressors in household refrigerators. -Applied Thermal Engineering, 2002, 22, p.1391-1402.
23. **Plastinin, P.I.** Theory and Calculations of Piston Compressors. -Moscow: Agropromizdat, 1987. -271p. [in Russian].
24. **Frenkel, M.I.** Piston Compressors. -Leningrad: Mashinostrojenie, 1969.-742p. [in Russian].
25. **Ooi, K.T.** Heat transfer study of a hermetic refrigeration compressor. -Applied Thermal Engineering, 2003, 23, p.1931-1945.

V. Dagilis, L. Vaitkus

SANDARAUS ŠALDYMO KOMPRESORIAUS PARAMETRINĖ ANALIZĖ

Резюме

Kompresoriaus efektyvumą nulemia keli faktoriai, kurie tarpusavyje susiję ir turi nevienodą įtaką. Didžioji energijos dalis sunaudojama garų suslėgimui. Ši dalis taip pat įtakoja kitas energijos sąnaudas - trinties nuostolius ir garų siurbimo bei slėgimo procesuose susidarancius nuostolius (indikatorinius nuostolius). Šių trijų nuostolių suma

gali būti nustatyta eksperimentiškai, bet juos atskirti yra sudėtinga. Šiame straipsnyje pateikiama kompresoriaus parametrinė analizė. Trinties nuostoliai skaičiuoti ir nustatyti eksperimentiškai. Energijos sąnaudos garų suslėgimui nustatytos matematinio modeliavimu bei apskaičiuotos pagal įprastas lygtis. Taip pat pateikti metodai indikatoriinių nuostolių įvertinimui bei jų palyginamoji analizė. Straipsnis rodo, kad matematinis modeliavimas leidžia pakankamai tiksliai nustatyti trinties nuostolius.

V. Dagilis, L. Vaitkus

PARAMETRIC ANALYSIS OF HERMETIC REFRIGERATION COMPRESSORS

Summary

Compressor’s efficiency consists of several factors, which are interconnected and have different influence. The biggest amount of energy is used for vapour compression. This part also influences other components of energy consumption – losses for friction and losses in the processes of suction and discharge of vapour (indicated losses). The sum of the three components of energy consumption can be determined experimentally, but it is difficult to distinguish them. This article presents parametric analysis of compressor. Friction losses were calculated and determined experimentally. Energy consumption for vapour compression was determined by the means of mathematical modelling and also calculated according to standard equations. Methods for estimation of indicated losses and their comparative analysis are also presented. The article shows that friction losses can be determined through mathematical modelling with reasonable accuracy.

В. Дагилис, Л. Вайткус

ПАРАМЕТРИЧЕСКИЙ АНАЛИЗ ГЕРМЕТИЧНЫХ ХОЛОДИЛЬНЫХ КОМПРЕССОРОВ

Резюме

Эффективность компрессора зависит от нескольких факторов, которые взаимосвязаны и имеют разное влияние. Большая часть энергии расходуется на сжатие паров. Эта часть также влияет на другие компоненты расходов энергии – потери на трение и потери в процессе всасывания и нагнетания паров (индикаторные потери). Сумму всех трех компонентов можно определить экспериментально, однако их разделить сложно. В статье представлен параметрический анализ компрессора. Потери на трение были рассчитаны и определены экспериментально. Энергия для сжатия паров определена при помощи математического моделирования и рассчитана с использованием стандартных уравнений. Также представлены методы для определения индикаторных потерь и их сравнительный анализ. Статья показывает, что потери на трение с достаточной точностью могут быть определены при помощи математического моделирования.

Received September 02, 2009
Accepted December 07, 2009

DOI: 10.5755/j02.mech.15497