

## Calibration of the multiangular prism (polygon)

D. Bručas\*, V. Giniotis\*\*, G. Augustinavičius\*\*\*, J. Stepanovienė\*\*\*\*

\*Vilnius Gediminas Technical University, Saulėtekio al. 11, 10223 Vilnius, Lithuania, E-mail: domka@ktv.lt

\*\*Vilnius Gediminas Technical University, Saulėtekio al. 11, 10223 Vilnius, Lithuania, E-mail: vytautas.giniotis@vgtu.lt

\*\*\*Vilnius Gediminas Technical University, Saulėtekio al. 11, 10223 Vilnius, Lithuania, E-mail: giedaugust@yahoo.com

\*\*\*\*Vilnius Gediminas Technical University, Saulėtekio al. 11, 10223 Vilnius, Lithuania, E-mail: jst@ap.vgtu.lt

### 1. Introduction

The autocollimator/multiangular prism (polygon) angle measurement principle has been considered as the most precise means of angular position determination for a long time. This method of angle determination still remains as the national angle reference in most of the countries. Therefore the calibration of one of the elements of the measurement system – the multiangular prism – is of extreme importance.

The multiangular prism is a precise polygon that has precise flat mirror faces; the angle between the mirrors is being known and very precise. Usually a multiangular prism consists of 12–20 or 24, 36 or even 72 faces (Fig. 1). Multiangular prisms are usually produced from certain steel or quartz glass. Often for the determination of small angles a single measuring mirror is being used instead of the entire multiangular prisms [1].



a



b

Fig. 1 Examples of polygon (pictures taken at PTB):  
a - with 8 mirror faces, b - with 72 mirror faces

The angle between the surfaces of the multiangular prism is considered to be the reference angle and in most cases its error value does not exceed a tenth of an arc second. The main disadvantage of a multiangular prism is

that positioning angles of the tested devices equal to the angles between the polygon edges are measured. Thus with the help of one polygon and one autocollimator it is possible at a certain pitch (depending on the number of polygon edges) to determine edge values of the tested device (test rig in our case) within a full circle. Alternatively the very small angular values can be determined using the same face of the multiangular prism.

While being one of the most accurate means of angular position determination, the autocollimator/multiangular prism is still not free of errors. Main systematic errors (biases) of the measurements can be caused by both the autocollimator and the multiangular prism. To obtain precise angle measurements both of these instruments must be calibrated.

Autocollimators are usually calibrated against small angle generators of various constructions, therefore the calibration curve for each particular autocollimator is obtained [2]. Generally the sources of systematic errors of the measurements performed by autocollimators are:

- influence of the nonparallelism of beams (autocollimator is not focused to infinity);
- systematic errors of the CCD matrix;
- errors caused by the optical system of the autocollimator;
- errors caused by the CCD orientation (CCD matrix is not perpendicular to the beams).

The systematic errors of multiangular prism are usually caused by:

- deviations of the angles between mirror faces;
- pyramidity of mirror faces;
- flatness deviations of the mirror faces.

Since the influence of pyramidity of mirror faces on the accuracy of measurement is not clearly defined by today (though that influence is clearly present) there is still no unambiguous method for elimination of these errors.

Similarly, the effect of flatness deviation of the mirror surfaces can be determined (Fig. 2). Its influence on the measurements however can not be clearly evaluated and the errors compensated. A large number of methods for reduction of mirror flatness deviation errors exist but there is still no single unambiguous method proposed [3].

On the other hand the deviations of angles between the mirror faces of the multiangular prism can be clearly determined, evaluated and quite easily corrected in the course of measurement data processing.

There are various calibration methods of angles between mirror faces of multiangular prism (polygon) most of which are based on the cross, direct comparison or simple calibration principles [4, 5].

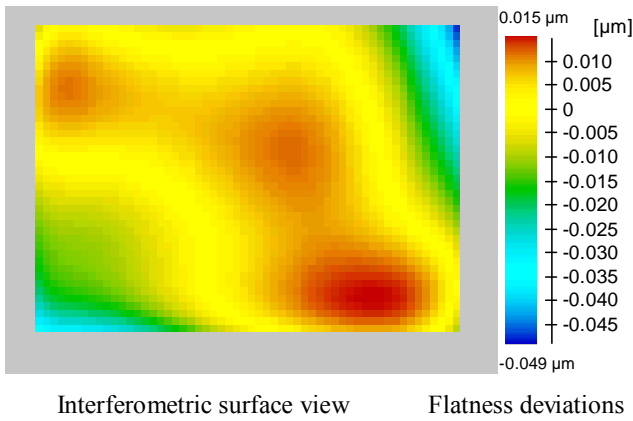

Interferometric surface view Flatness deviations  
Fig. 2 Example of the flatness deviations of the mirror surface

In this paper we describe the experiment of calibration of *Hilger&Watts* based on a 12 sided multiangular prism by the use of a precise automated rotary table produced by the *Wild* company (now *Leica*) and two autocollimators.

## 2. Settlement and the experiment

The *Hilger&Watts* 12 sided (having 12 reflective surfaces) precision polygon is very frequently used for the tasks in the calibration laboratory of the Institute of Geodesy of Vilnius Gediminas Technical University (VGTU). The mentioned polygon has been calibrated at PTB (Physikalische-Technische Bundesanstalt) National Metrology Institute in Braunschweig, Germany in 2007. In order to accomplish the time-span control of the accuracy of the polygon the calibration of the same polygon was performed at VGTU.

For the calibration (of the base table) a rotary table has been constructed by the *Wild Heerbrugg* company (now *Leica*) in Switzerland and transferred to VGTU. It was formerly used by the Swiss Federal Institute of Technology. The rotary table includes a dynamic encoder for angular position determination and was used for testing of geodetic angle measuring instruments in the past [6]. It has a rotation step length of  $4.5''$  and a measuring sensibility of  $0.0324''$ . The theoretical repeatability of the system is in the range of  $0.03''$ , and the experimental standard deviation stated by the manufacturer has never exceeded  $0.32''$  [7]. The systematic errors of the particular rotary table have not yet been determined (since there were no devices of higher accuracy available for use as reference), but the standard deviation of measurements have been experimentally determined and did not exceed  $0.166''$ .

In addition, two autocollimators (initially produced by *Hilger&Watts*) were also used for calibration. Both autocollimators were modified at Kaunas University of Technology by fitting the CCD matrices to the optical autocollimators and thus obtaining the digital output of measurements. Autocollimators return the position (in the horizontal axis) of the reflected mark (stroke) in the form of the number of pixels from the beginning of the axis. In the computer program the view received from the CCD matrix is analyzed and depending on the CCD pixels illumination ( $y$  axis) dependence of pixel position ( $x$  axis) graph is created. The position ( $x$  axis) value of the peak centre is established in pixels; therefore later the device

needs to be calibrated to attribute the pixels values to arc seconds. The experiment performed is especially interesting since two autocollimators calibrated have been constructed by modifying the optical instruments. Since the autocollimators have been custom made, their performances are not clearly known.

Before the polygon calibration, both autocollimators were calibrated at a pitch of  $9''$  using the same rotary table and characteristic curves of autocollimator measurements were determined [8]. Mentioned characteristic curves were evaluated using 3rd order polynomial for autocollimator *I*:

$$y = -1.084 \cdot 10^{-8} x^3 + 1.57 \cdot 10^{-5} x^2 + 0.205x \quad (1)$$

and for autocollimator *II*

$$y = 1.048 \cdot 10^{-8} x^3 - 1.2 \cdot 10^{-5} x^2 - 0.330x \quad (2)$$

where  $x$  is autocollimator measure in pixels, and  $y$  is the value of determined angular position in arc seconds (determined regarding the reference measure).

These equations were used for transformation of pixel measurements to arc seconds during the experiment.



Fig. 3 Instruments arrangement

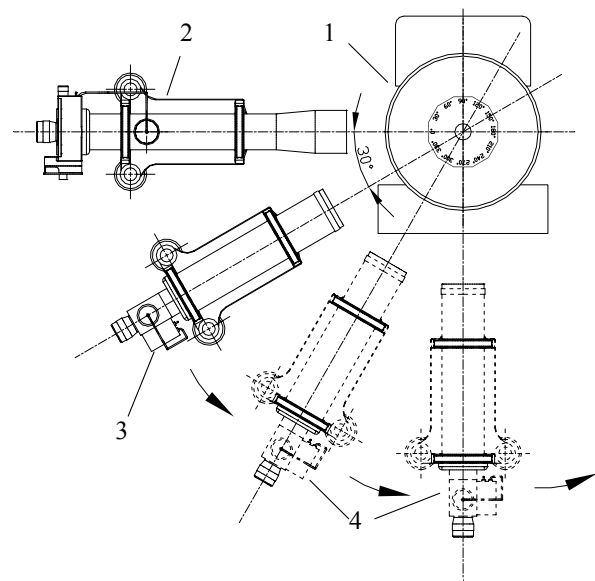

Fig. 4 Instruments arrangement for calibration: 1 - rotary table, 2 — Autocollimator I, 3 - Autocollimator II, 4 - Autocollimator II after repositioning

During experiment the calibrated polygon was placed on the rotary table and two autocollimators were pointed to different mirror faces (of polygon). Initially autocollimator I was pointed to 0° and autocollimator II to 30° mirror surface (Fig. 3). After the full circle measurement (with the measurement stops at every 30°) autocollimator II was pointed to 60° mirror face of polygon and measurements were repeated. Therefore autocollimator II was consequently moved each time next to another polygon surface and full circle measurements were repeated (Fig. 4).

After the mentioned measurements the accuracy of polygon could be determined in two almost independent (disregarding the measures of autocollimator I) ways – direct comparison (comparation) of polygon/autocollimator I (or II) measures to the ones obtained by the encoder of rotary table (i.e. angular position of polygon); and “simple” calibration by means of two autocollimators (Autocollimator I/Autocollimator II) [5].

### 3. Results of the experiment

After processing of the experiment data (including autocollimators calibration data) the results were ob-

tained. It was determined that standard deviation of measurements performed by autocollimators (in this case, since the position of polygon was determined by rotary table encoder, standard deviation could be considered as combined one of the table encoder/polygon/autocollimator) were for Autocollimator I – 0.127” (uncertainty 0.223”) and for Autocollimator II – 0.381” (uncertainty 0.671”). Its obvious that standard deviation of Autocollimator II measurements is much higher (thus accuracy lower) which could be explained by the lower resolution of Autocollimator II (2) therefore accuracy is lower and probably due to the influence of repositioning of the autocollimator along the circle (lower stability of repositioned object temperature changes due to manual repositioning, etc.) according to the calibration method.

The direct comparison of the measurements of Autocollimator I and Autocollimator II (with sequential shift of data by 30°) to the rotary table angular position (measured by the table encoder) are shown in Table and Fig. 5.

After the calculation of “simple” polygon calibration the deviations of the polygon mirror faces were determined disregarding the rotary table positioning errors (Table and Fig. 5).

Table

Results of the angle measurement tests

Polygon face, deg	Polygon face deviation (arc sec), determined by:				Deviations from PTB data, arc sec		
	PTB	"Simple" calibration	Autocollimator I/rotary table	Autocollimator II/rotary table	"Simple" calibration	Autocollimator I/rotary table	Autocollimator II/rotary table
0	1.18	1.299	1.295	1.229	0.119	0.115	0.049
30	-1.70	-1.936	-1.870	-2.015	-0.236	-0.170	-0.315
60	0.27	0.227	0.401	-0.039	-0.043	0.131	-0.309
90	-1.09	-1.237	-1.129	-1.231	-0.147	-0.039	-0.141
120	2.04	2.183	1.923	2.478	0.143	-0.117	0.438
150	0.63	0.670	0.671	0.604	0.040	0.041	-0.026
180	0.11	0.297	0.053	0.528	0.187	-0.057	0.418
210	-1.85	-1.904	-1.919	-1.976	-0.054	-0.069	-0.126
240	1.13	1.125	0.964	1.248	-0.005	-0.166	0.118
270	0.92	0.905	1.047	0.796	-0.015	0.127	-0.124
300	-0.26	-0.352	-0.147	-0.379	-0.092	0.113	-0.119
330	-1.38	-1.277	-1.290	-1.244	0.103	0.090	0.136

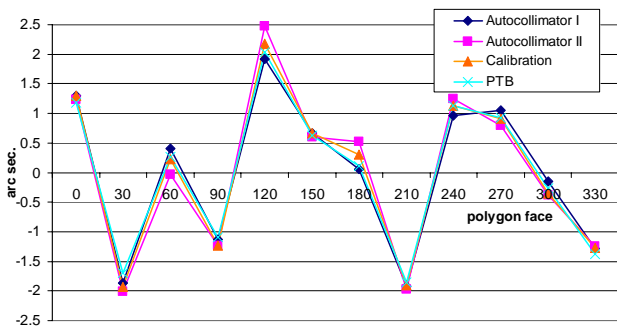

Fig. 5 Polygon mirror face angular deviations determined by different means

As it can be seen from Fig. 5 polygon face angular deviation determined by different means is very similar. Though it should be noted, that according to calibration results the tested polygon is not of a highest quality.

Considering that the polygon calibration data determined by PTB was reference (since the equipment of

much higher stated accuracy was used) the deviations of all types of calibration measurements performed were calculated (Table and Fig. 6).

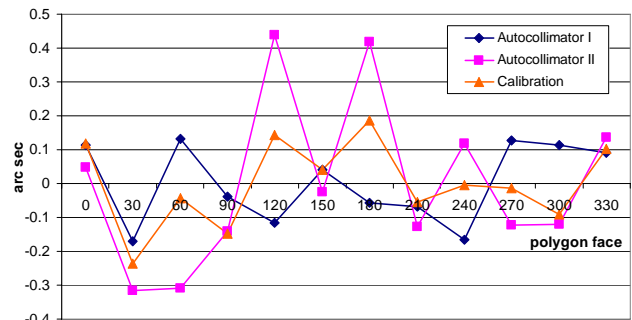

Fig. 6 Deviations of calibration data compared to the PTB data (considered as reference)

As can be seen from Table and Fig. 6 the highest deviations from the reference values (PTB data) are of the

measurements performed by Autocollimator II/rotary table (standard deviation – 0.116", uncertainty – 0.204"), the most accurate measurements being by Autocollimator I/rotary table (standard deviation – 0.245", uncertainty – 0.409") and "simple" calibration has been influenced by both autocollimator measurements (standard deviation – 0.125", uncertainty – 0.220").

According to the results both rotary table encoder and Autocollimator I showed quite high accuracy (which was predictable for Autocollimator I), the deviations from reference values being not larger than 0.17". Since Autocollimator II showed quite poor results (largest deviation 0.438") the results of "simple" calibration (Autocollimator I/Autocollimator II) are also of quite low accuracy (largest deviation – 0.236").

It should be noted that the experiment was held on a sunny day with the sun constantly appearing from the cloud and therefore causing unstable refractions of optical instruments (it was tried to avoid such effect during measurements nonetheless it was present) disturbing the measurements, additionally constant moving of the Autocollimator II by the operator could cause unpredictable fluctuations of air masses of different temperature thus causing instabilities of measurements (such effect was observed during other measurements) [9]. As was mentioned before the instabilities of the placement of Autocollimator II due to its constant movements could also influence the accuracy considerably [10]. Thus avoiding of all of the mentioned factors – shading the sun light, automated moving of the autocollimator without physical interruption of operator and remote control of equipment (without the need for operator to be at the same room) should influence the increasing of general measurements accuracy.

Additionally the deviations of the polygon/autocollimator measurements depend on the flatness deviations of the polygon faces, therefore measurement accuracy depends on the polygon face area autocollimator is pointed at and such influence can not be unambiguously evaluated [3]. Such effect could influence the accuracy of measurements – Autocollimator I was constantly pointed to the same area of mirror faces though Autocollimator II was each time pointed to a different face area (due to repositioning it was impossible to point to the same area). Having in mind that polygon tested has quite significant mirror surface flatness deviation (surface flatness deviations of tested polygon were measured at PTB, Fig. 2), especially at the sides of the mirrors, mentioned errors could be present. Same can be said about the calibration procedure performed at PTB – it is unknown at what areas of polygon mirror surfaces autocollimator (used for calibration) was pointed.

Having in mind that standard deviation of polygon calibration is stated 0.1", calibration performed by Autocollimator I/rotary table can be evaluated as having total standard deviation of 0.151" (uncertainty – 0.266"), Autocollimator II/rotary table – 0.161" (uncertainty – 0.283"), "simple" calibration (Autocollimator I/Autocollimator II) – 0.287" (uncertainty – 0.505").

According to the results of calibration it might be stated that the best results at present conditions can be obtained implementing Autocollimator I and rotary table. "Simple" calibration procedure can not be straightly implemented (despite quite high accuracy) since it depends

on Autocollimator II measurements results of which are quite unpredictable.

It should be also noted that the results obtained can hardly be checked due to the lack of instrumentation of sufficient accuracy not only in Lithuania, but also in the world (there are very few laboratories worldwide capable of high accuracy angle measurements).

## 5. Conclusions

1. Two methods of precision polygon (multangular prism) calibration were tested – "simple" calibration and direct comparison using high accuracy rotary table and an autocollimator;

2. The experimental total standard deviation of the calibration was Autocollimator I/rotary table – 0.151" (uncertainty – 0.266"), Autocollimator II/rotary table – 0.161" (uncertainty – 0.283"), "simple" calibration (Autocollimator I/Autocollimator II) – 0.287" (uncertainty – 0.505");

3. The results of the highest accuracy were obtained by simple comparison between the autocollimator (Autocollimators I) measurements and the angular position of rotary table. This method of polygon calibration can be implemented "as is" at present conditions;

4. Both Autocollimator II/rotary table and "simple" calibrations showed worst results due to the influence of errors of Autocollimator II which can hardly be decreased at present conditions.

5. The accuracy of calibration (and measurements in general) could be increased by implementing better control of the laboratory environment, i.e. increasing the level of automation and the settlement time before the measurement begins.

## Acknowledgments

This work has been funded by the Lithuanian State Science and Studies Foundation, Project No B-32/2008.

## References

1. **Giniotis, V.** Measurements of Position and Displacement. -Vilnius: Technika, 2005.-215p (in Lithuanian).
2. **Just, A., Krause, M., Probst, R., Wittekopf, R.** Calibration of high-resolution electronic autocollimators against an angle comparator. -Metrologia, 2003, 40, p.288-294.
3. **Probst, R., Wittekopf R.** Angle Calibration on Precision Polygons: Final Report of EUROMET Project #371.-Braunschweig: Physikalisch-Technische Bundesanstalt (PTB), 1999.-20p.
4. **Watanabe, T., Fujimoto, H., Nakayama, K., Kajitani, M., Masuda, T.** Calibration of a polygon mirror by the rotary encoder calibration system. -XVII IMEKO World Congress, Dubrovnik, Croatia, 2003, p.1890-1893.
5. **Cook, A.H.** The calibration of circular scales and precision polygons. -British Journal of Applied Physics, 1954, 5, p.367-371.
6. **Ingensand, H.** A new method of theodolite calibration. -XIX International Congress, Helsinki, Finland, 1990, p.91-100.

7. **Katowski, O., Salzman, W.** The angle-measurement system in the Wild Theomat T2000. -Wild Heerbrugg Ltd. Precision Engineering, Optics, Electronics, Heerbrugg, Switzerland, 1983, p.1-10.
8. **Bručas, D., Giniotis, V., Ingensand, H.** Output signal accuracy calibration of autocollimators. -Journal of Vibroengineering, 2009, vol.11(3), p.503-509.
9. **Marcinkevičius, A.H.** Automatic control of longitudinal form accuracy of a shaft at grinding. -Mechanika. -Kaunas: Technologija, 2008, Nr.1(69), p.63-68.
10. **Garjonis, J., Kačianauskas, R., Stupak, E., Vadluga, V.** Investigation of contact behaviour of elastic layered spheres by FEM. -Mechanika. -Kaunas: Technologija, 2009, Nr.3(77), p.5-12.

D. Bručas, V. Giniotis, G. Augustinavičius,  
J. Stepanovienė

#### DAUGIAKAMPĖS PRIZMĖS KALIBRAVIMAS

##### Re z i u m ė

Daugiakampės prizmės iki šiol laikomos tiksliausiomis iš plačiai prieinamų kampų matavimo priemonių. Daugiakampės prizmės ir autokolimatoriaus matavimo sistema labai plačiai taikoma kampų matavimo prietaisų, sukamųjų staliukų ir kitų įrenginių tikslumui tikrinti ir jiems kalibruoti. Dėl šių priežasčių daugiakampės prizmės kalibravimas ir tikslumo tyrimas nagrinėjamas daugelyje pasaulinio lygio metrologijos laboratorijų. Literatūroje aprašoma daug daugiakampės prizmės kalibravimo metodų. Šiame darbe, naudojantis turimais matavimo prietaisais, lyginamas dviejų kalibravimo metodų – „paprastojo“ kalibravimo ir komparavimo tikslumas. Remiantis tyrimo rezultatais didžiausias kalibravimo tikslumas (0.151" standartinė nuokrypa, lyginti su PTB atlikto kalibravimo rezultatais) buvo pasiektas naudojantis didelio tikslumo sukamojo staliuko bei daugiakampės prizmės ir autokolimatoriaus rodmenų komparavimu. Kitas kalibravimo metodas („paprastasis“ kalibravimas) dėl laboratorijos aplinkos sąlygų netobulumo ir automatizavimo stokos yra ne toks tikslus. Eksperimento rezultatai parodė, jog gana didelis daugiakampių prizmių kalibravimo tikslumas gali būti pasiektas esamomis laboratorijos sąlygomis, naudojantis turima matavimo įranga.

D. Bručas, V. Giniotis, G. Augustinavičius,  
J. Stepanovienė

#### CALIBRATION OF THE MULTIANGULAR PRISM (POLYGON)

##### S u m m a r y

Precision polygons (multiangular prism) are by now considered to be the most accurate relatively widely available mean of angle measurement. Polygon/autocollimator measurement system is implemented for various tasks such as accuracy testing and calibration

angle measuring instruments, rotary tables etc. Therefore determination of accuracy and calibration of the polygons is an important task analysed and performed at most of the high level metrology laboratory worldwide. There are various methods of calibration of precision polygons described in the literature; here in this paper we present the comparison test of two calibration methods – “simple” calibration and comparison, with the use of instrumentation available. According to the results the highest accuracy (standard deviation of 0.151" compared to the results of calibration performed at PTB) was reached implementing comparison of high accuracy rotary table measurements with tested polygon/autocollimator. Other calibration method (“simple” calibration) showed worst accuracy due to the imperfection of measurement environment. The results of the experiment showed that relatively high accuracy of precision polygon calibration can be reached even with available level of instrumentation, automation and environmental conditions control.

Д. Бручас, В. Гиниотис, Г. Аугустинавичус,  
Я. Степановиене

#### КАЛИБРИРОВАНИЕ МНОГОГРАННЫХ ПРИЗМ (ПОЛИГОНОВ)

##### Р е з ю м е

Полигоны (многогранные призмы) до сих пор считаются самыми точными из широко доступных угломерных приспособлений. Измерительная система полигон/автоколлиматор используется для разных целей, таких как проверка точности и калибрование угломерных приборов, поворотных столиков и т.п., в связи с чем установление характеристик точности и калибрование полигонов является важной задачей, которую исследуют и выполняют многие метрологические лаборатории во всём мире. В литературе описано несколько разных методов калибрования полигонов. В данной статье описывается сравнение двух методов калибрования – “простое” калибрование и компарирование с использованием доступных средств и инструментов. По результатам исследования наилучшая точность (стандартная девиация 0,151" по сравнению с результатами калибрования проведенного в РТВ) была достигнута применяя компарирование измерений высокоточного поворотного столика и тестируемого полигона/автоколлиматора. Другой метод калибрования (“простое” калибрование) не дало желаемой точности в связи с несовершенством окружающей среды лаборатории и недостатком автоматизации. Результаты эксперимента показали, что возможно достичь довольно высоких результатов точности калибрования полигонов даже при ныне имеющемся уровне инструментов, автоматизации и контроле окружающей среды.

Received March 17, 2010  
Accepted June 21, 2010

DOI: 10.5755/j02.mech.15922