

Pneumatic transport of granular materials over plane using concentrated air flow

M. Palšauskas*, J. Bozys**, E. Jotautienė***

*Lithuanian University of Agriculture, Studentų 11, 53361 Akademija Kauno dist., Lithuania, E-mail: mecys@meruva.lt

**Lithuanian University of Agriculture, Studentų 11, 53361 Akademija Kauno dist., Lithuania, E-mail: mm@lzuu.lt

***Lithuanian University of Agriculture, Studentų 11, 53361 Akademija Kauno dist., Lithuania,

E-mail: egle.jotautiene@lzuu.lt

1. Introduction

Agricultural products of granular materials are often transported by air flow over a plane surface. The application of this process allows the material to be transported to a destination and at the same time the substance is cooled providing in most cases a positive effect on the output persistence [1-4].

The pneumatic transport plane depends on air flow that is controlled by the number and shape of holes and the flow velocity [5, 6]. However, this transport process is not well defined often resulting in a difficulty of selecting the appropriate equipment [5]. A number of authors of various firms in different countries provide description of the required transport facilities in their patent promotional material [7, 8]. However, data on the selection on aerodynamic parameters are not completely specified. This paper provides an analysis on the interaction of air flow with granular agriculture products that are transported by a pneumatic plane.

2. Theoretical analysis

For analysis of pneumatic transport of bulk materials process, the plane was invoked mathematical expressions used to calculate the initial velocity of air needed to inflate the transported material from a certain area [6].

The process of moving bulk of granular materials by pneumatic transport plane mainly depends on air flow, which is formed by a number of holes and speed [3-5]. The critical air velocity V_{cr} can be calculated from [6]

$$V_{cr} = \sqrt{\frac{2mg}{kF\rho}} \quad (1)$$

where m is particle mass, kg; g is acceleration due to gravity, m/s^2 ; k is proportionality factor; F is particle surface area, m^2 ; ρ is air density, kg/m^3 .

The air blown through the hole in the plane is provided by air flow velocity torch. The air flow velocity V_{ij} at a selected location can be determined from [6]

$$V_{ij} = V_0 e^{-2\sqrt{x_i^2 + y_j^2}} \left[1 - \left(\frac{y_j}{\frac{a}{2} - S_0 + x_i(tg\beta + 1)} \right)^{1.5} \right]^2 \quad (2)$$

where V_0 is the initial air velocity, m/s; a is air flow width

of the hole, m; S_0 is air traffic walkway from the hole before the collision with the plane, m; x, y are the reference point coordinates, m; β is air flow lateral dispersion angle, in degrees.

The transport plane will inflate the substance in the torch shaped area, that will define the parameters of air flow velocity of $V_{ij} = V_{cr}$. The initial air speed required to inflate the material transported from the parameters space can be calculated [6]

$$V_0 = \frac{\sqrt{\frac{2mg}{kF\rho}}}{e^{-2\sqrt{x_i^2 + y_j^2}} \left[1 - \left(\frac{y_j}{\frac{a}{2} - S_0 + x_i(tg\beta + 1)} \right)^{1.5} \right]^2} \quad (3)$$

The results shown in Fig. 1 indicate a good agreement between the theoretical predictions and experimental measurements. Thus, the mathematical expressions provide a realistic procedure to estimate the required parameters for air flow transport of granular agriculture products.

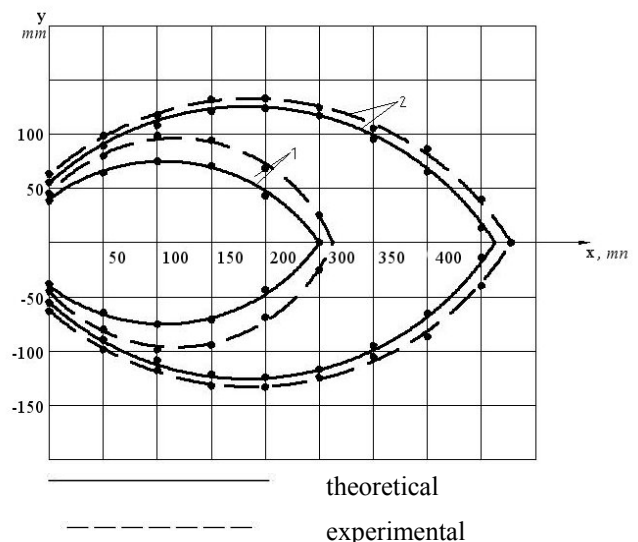

Fig. 1 Theoretical and experimental diagrams, the inflated air flow grain layer, the dependence on the initial air velocity V_0 : 1- $V_0 = 30$ m/s; 2- $V_0 = 40$ m/s

The authors set itself the objective to explore different forms of openings that form air flow, power transported material.

At the examination of different forms and dimen-

sions of holes (circular, triangular, square, rectangular with a different aspect ratio) settings in the tunnels it was found that the most effective is a rectangular hole with an aspect ratio of 1:62, [3].

The air jet streams flowing from such openings are parallel, and their speed depends on the volume of air passing through the hole and on the cross-sectional area. The speed for different system parameters can theoretically increase the bend of rectangular (slit) opening under the form of a transverse projection axis. Then, the air flow through F is reduced in the projection area perpendicular to the plane of the cross-sectional area without holes.

The air flow velocity projection plane is found as follows:

$$V = \frac{Q}{F_\gamma \sin \gamma} \quad (4)$$

where V is air velocity, m/s, Q is effluent flow from the outlet air volume, m^3/s ; F_γ is slit-shaped opening area at the bent angle, m^2 ; γ is the bend angle, in degrees.

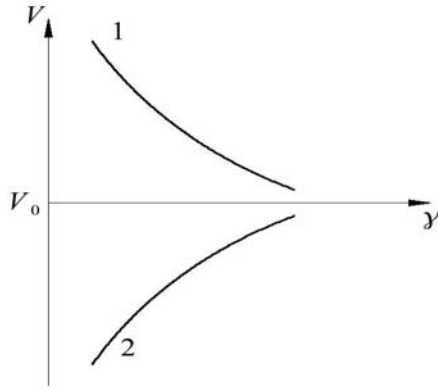

Fig. 2 Air flow rate dependence on the gap bending angle

In Fig. 2 curve 1 shows the air flow velocity dependence on the gap bending angle. When angle γ is approaching zero, the velocity increased. On the other hand, bent in the slot can be viewed as a complex consisting of two rectangular openings connected to each other at an angle γ . Then, the effluent from an outlet should be split into two interacting (competing) air flows. The collision of air particles lose some of their kinetic energy and velocity decreases. In this case $\gamma \rightarrow 0$, the velocity decrease as shown in Fig. 2, curve 2.

It can be expected to decrease the angle γ down to a certain value γ' . The air flow rate increase at the expense of the projection area decline is greater than the rate of reduction of energy loss in the face particles. This phenomenon is explained by the fact that the initial phase angle downward flow of air is as if the jet slip against each other without significant particle collisions.

The depleted air stream torch base width of the slit-fold increase in pressure at the centre. This phenomenon can be explained by the fragmentation of air flow into two distinct streams, which at a certain angle of bending gap faces torch at the centre and slip relative to one another. The emerging force is at the time due to the outermost layer boundaries γ_r spread at an angle $\Delta\beta$ relative

to the expansion of air flow at an angle, where $\gamma = 180^\circ$ (Fig. 3). Thus, $\Delta\beta = f(\gamma)$.

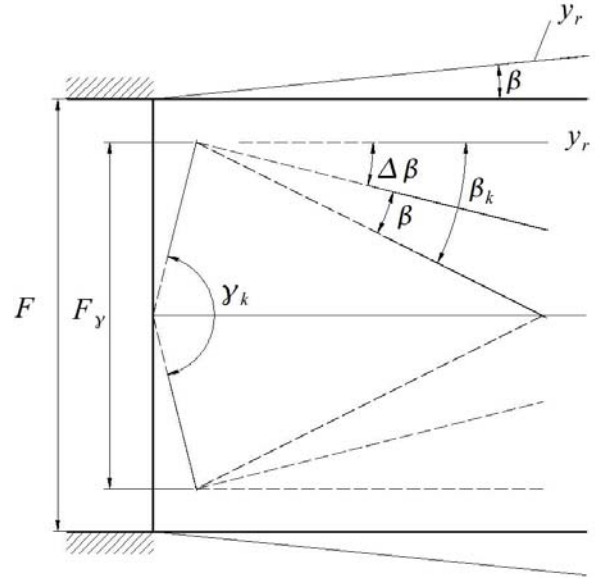

Fig. 3 Air traffic collision scheme, bent slot: F is the gap width, $\gamma = 180^\circ$, m ; F_γ is the gap width when it is bent at an angle γ , m

Torch wide change analysis showed that this functional dependence can be expressed as follows

$$\Delta\beta = \frac{\pi}{4} \cos \frac{\gamma}{2} \quad (5)$$

and

$$\beta_k = \beta \frac{\pi}{4} \cos \frac{\gamma_k}{2} \quad (6)$$

where β_k is lateral expansion of the air flow torch angle, k -th gap bending angle, in degrees; β is air flow torch lateral expansion angle at $\gamma = 180^\circ$, in degrees; γ_k is k -th gap bending angle, in degrees.

In this case, the air flow speed field V_{ij} , where $\gamma = 180^\circ$, was previously described in Eq. (2). The distance S_0 from the gap for air traffic collision with the plane is

$$S_0 = \frac{h}{\sin \alpha} \quad (7)$$

where h is the distance from the gap before the plane, m ; α is the angle at which the air flow is directed into the plane, in degrees.

The proportionality factor C based on experimental studies was determined to have the following relationship

$$C = \frac{1}{k_1 \gamma^2 + k_2 \gamma + k_3} \quad (8)$$

where k_1, k_2, k_3 are the regression coefficients.

Using the proportionality factor, the suitable an-

gles γ was determined. Then, at V_{ij} will be the highest volume of air passing when

$$V_{ij} = \frac{V_0}{k_1\gamma^2 + k_1\gamma + k_3} e^{-2\sqrt{x_i^2 + y_j^2}} \times \left[1 - \left(\frac{y_j}{\frac{a_0}{2} \sin \frac{\gamma}{2} - \frac{h}{\sin \alpha} + x_i \left[\operatorname{tg} \left(\beta - \frac{\pi}{4} \cos \frac{\gamma}{2} \right) + 1 \right]} \right)^{1.5} \right]^2 \quad (10)$$

The complete information on the initial air velocity needed to inflate the material was obtained by experiments. Measurements were performed using special laboratory stand (Fig. 4). For an excited air flow in the pipe the fan was used. The grain was used for investigation the bulk material transport over plane. The values of $V_0 = 30, 40, 50, 60$ m/s, $\alpha = 8^\circ$, $a = 100$ mm; $h = 40$ mm and $\beta = 18^\circ$ were used in Eq. (10) to calculate the air flow velocity at

the points located on the longitudinal axis of air flow torch at a distance of 0.1, 0.2, 0.3 m from its base on the plane. The gap bending angle was changed from 180° to 150° every 5° (Table).

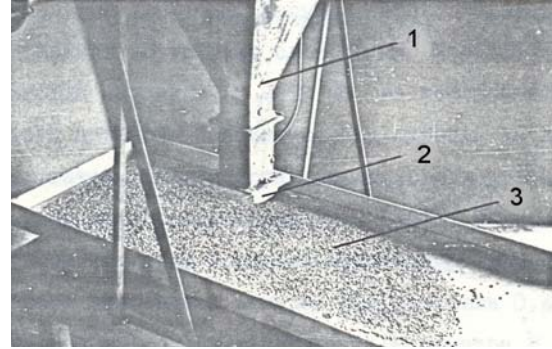

Fig. 4 General view of the laboratory stand: 1 - pressure chamber, 2 - pressure chamber nozzle, 3 - capacity with grain

The above results show that the maximum velocity of the air flow is at the angle $\gamma = 165^\circ$. Further reduction of the gap bending angle decreases the air flow velocity.

Table

The air flow velocity on the x-axis of the torch

Opening the bending angle, $^\circ$	Air flow inlet velocity V_0 , m/s			
	30	40	50	60
V_1 , distance of 0.1 m, m/s				
180	19.84	26.46	33.08	39.70
175	20.96	27.95	34.94	41.92
170	21.57	28.76	35.96	43.15
165	21.58	28.77	35.97	43.15
160	20.99	27.96	34.98	41.97
155	19.87	26.50	33.12	39.75
150	19.42	24.56	30.70	36.84
V_2 , distance of 0.2 m, m/s				
180	16.25	21.66	27.08	32.50
175	17.16	22.88	28.60	34.32
170	17.66	23.55	29.44	35.33
165	17.67	23.56	29.45	35.34
160	17.18	22.91	28.64	34.37
155	16.27	21.69	27.12	32.54
150	15.08	20.11	25.13	30.16
V_3 , distance of 0.3 m, m/s				
180	13.30	17.74	22.17	28.61
175	14.05	18.73	23.42	28.10
170	14.46	19.28	24.10	28.92
165	14.47	19.29	24.11	28.93
160	14.07	18.76	23.45	28.14
155	13.32	17.76	22.20	26.64
150	12.35	16.46	20.58	24.69

Using the developed formulas, it is possible to construct suitable parameters for transport of agricultural products. The presented calculation results show a good agreement with experimental measurements, confirming a practical and realistic application of this method for air transport of granular materials. This approach will allow to reduce energy needs when transporting bulk volume of materials by air flow.

4. Conclusions

1. The initial air velocity needed to inflate the material to be transported from the surface area is obtained by a theoretical study and confirmed experimentally.
2. The examination of different forms and dimensions of the opening aerodynamic parameters of the suitable form at which the air flow velocity is the highest. The

suitable angles γ was determined using the proportionality factor.

3. The derived mathematical expressions of granular material transport by air flow enables to determine the best transport mode and to design parameters that can reduce energy needs.

References

1. **Alibi, B., Salau, T.A.O., Oke, S.A.** Fractal dynamics of a bouncing ball on accelerating lift tabletop with both constrained to vertical motion. -Mechanika. -Kaunas: Technologija, 2008, p.50-53.
2. **Bakšys, B., Kinzhebayeva D.** Displacement of the body on the oscillatory plane. -Mechanika. -Kaunas: Technologija, 2008, p.45-50.
3. **Kajalavičius, A.** Shredded Wood Pneumatic Transport. -Kaunas: Technologija, 2001.-69p (in Lithuanian).
4. **Malevic, I. P., Matveev, A. I.** Building Materials Pneumatic Transport. -Moscow: Strojizdat, 1979.-142p. (in Russian).
5. **Petrusevicius, V., Raila, A.** Production of Plants Drying Thick, Rigid Layer: monograph /: Lithuanian University of Agriculture. - The Academy (Kaunas district): Lithuanian Land University Publishing Center, 2009.-262p. (in Lithuanian).
6. **Palšauskas, M., Bozys, J., Jotautienė, E.** Analysis of assumptions and possibilities of pneumatic transport plane. ISSN 1822-2951. -Proc. of 15th International Conference "Mechanika 2010". -Kaunas: Technologija, 2010, p.338-340.
7. **Lee, L.Y., Quek, T.Y., Deng, R., Ray, M.B., Wang, C.H.** Pneumatic transport of granular materials through a 90° bend. Chemical Engineering Science.-Elsevier, 2004. p.4637-4651.
8. **Louge, M.Y., Mastorakos, E., Jenkins J. T.** The role of particle collisions in pneumatic transport. **231**:345-359. -J. of Fluid Mechanics. -Cambridge University Press. Published Online 2006.

M. Palšauskas, J. Bozys, E. Jotautienė

BIRIŲJŲ MEDŽIAGŲ PNEUMATINIS TRANSPORTAVIMAS PLOKŠTUMA KONCENTRUOTU ORO SRAUTU

Резюме

Straipsnyje nagrinėjamas biriųjų medžiagų pneumaticinis transportavimas plokštuma. Šis procesas daugiausia priklauso nuo oro srauto greičio, kurį formuoja tam tikros formos anga. Teoriškai apskaičiuotas pradinis oro greitis, reikalingas transportuojamai medžiagai išpūsti iš nustatyto paviršiaus ploto, bei eksperimentais patvirtinta, kad sudarytos matematinės medžiagų transportavimo oro srautu išraiškos atitinka realų procesą. Eksperimentais nustatyta tinkamiausia angos forma, kuriai esant oro srauto greitis yra didžiausias. Naudojantis gautomis formulėmis

nustatytas biriųjų produktų transportavimo oro srautu geriausias režimas ir naudojamos įrangos konstrukciniai parametrai, kas leidžia sumažinti šio technologinio proceso energijos poreikius.

M. Palšauskas, J. Bozys, E. Jotautienė

PNEUMATIC TRANSPORT OF GRANULAR MATERIALS OVER PLANE USING CONCENTRATED AIR FLOW

Summary

The article provides the granular material pneumatic transport by a plane. Since this process mainly depends on air flow velocity, which is formed by certain holes, a theoretical procedure is provided estimate the initial velocity that is needed to inflate the transported material from the plane surface and by experiments it was confirmed that the presented mathematical expressions of material transport by air flow are a realistic process. The suitable opening of the holes at which the air flow velocity is at maximum has been determined by experiments. The developed mathematical equations were used to improve air flow for granular material transport and to obtain construction parameters of the required industrial equipment. The method will provide means to reduce the energy needs for this technological process.

М. Палшаускас, Й. Бозис, Е. Йотаугене

ПНЕВМАТИЧЕСКОЕ ТРАНСПОРТИРОВАНИЕ СЫПУЧИХ МАТЕРИАЛОВ ПО ПЛОСКОСТИ КОНЦЕНТРИРОВАННЫМ ПОТОКОМ ВОЗДУХА

Резюме

В статье рассматривается пневматическое транспортирование сыпучих материалов по плоскости. Поскольку этот процесс в значительной мере зависит от скорости воздуха, который формируется отверстием определенной формы, нами теоретически определена начальная скорость воздуха, необходимая для выдувания транспортируемого материала из установленной плоскости и экспериментами подтверждено, что математические выражения транспортирования материалов воздушным потоком соответствуют реальному процессу. Экспериментами установлена наилучшая форма отверстия, при которой скорость потока воздуха является максимальной. При помощи полученных формул определен наилучший режим транспортирования сыпучих материалов воздушным потоком, а также конструктивные параметры оборудования, что позволяет уменьшить энергоемкость технологического процесса.

Received May 10, 2010

Accepted August 27, 2010

DOI: 10.5755/j02.mech.15925