

# Investigation of low cycle asymmetric torsion

M. Daunys\*, R. Česnavičius\*\*

\*Kaunas University of Technology, Kęstučio 27, Kaunas, 44312, Lithuania, E-mail: mykolas.daunys@ktu.lt

\*\*Kaunas University of Technology, Kęstučio 27, Kaunas, 44312, Lithuania, E-mail: ramunas.cesnavicius@ktu.lt

## 1. Introduction

During exploitation the materials of constructions start gradually accumulate the damage, which finally causes fracture of the construction. The accumulation of damage occurs as a result of the high cycle and low cycle damage due to the cyclic overloads, which cause the elastic-plastic deformation. Especially dangerous is the overload as cyclically varying stresses exceed the proportional limit of the material and plastic strain starts, which results the hysteresis loop of the plastic strain and causes the reduction in material fatigue life up to thousands or hundreds cycles. It is defined that 75% of fracture of the mechanical systems' constructions occurs due to material fatigue [1 - 6].

The problems of metal fracture remain actual despite years of long-lasting investigation of the cyclic loading of metals. While selecting the material, it is necessary to know properties of the material and the laws change of their characteristics under different type loading in the areas of periodically varying elastic-plastic strain. In majority of the modern mechanisms and devices under loading the elastic-plastic deformation takes place in the stress concentration areas, near sudden change of the shape, e.g. in key seats, near shafts diameter changing places, as a result of incorrectly chosen fillet radius, in welded joints, because of the various welding defects and etc. [1, 7].

The considerable part of experiments related with the low cycle fatigue damage were carried out under the axial loading, i.e. under tension-compression and less of them at pure bending and the smallest part of scientific publications consider the torsion. The considerable amounts of the parts, operating in real exploitation conditions, are exactly under cyclically varying torsion loading (shafts of the mechanisms, springs and etc.).

Though the cyclically loaded parts work following the symmetrical cycle, however, different transitional forms also frequently occur. In real constructions the most common is asymmetrical loading (e.g. in the stress concentration areas, the crack areas), which results that both the hysteresis loop's width and also the fatigue life are highly dependent on the stress ratio [1, 7, 8].

## 2. Experimental setup and used specimens

The experimental analysis of the monotonic and also the low cycle torsion, considered in this paper, were carried out at room temperature. The specimens were tested under symmetric and asymmetric loading and strain data was recorded up to crack initiation. For the experimental fatigue analysis under monotonic and symmetric and asymmetric low cycle torsion the experimental low cycle setup, designed and made at Engineering design department of Kaunas University of Technology, was used.

Experimental setup consists of the testing machine with maximum possible  $T = 5$  kNm moment of torsion and the electronic part, which records the stress strain diagrams, semicycles and controls the motor reversal.

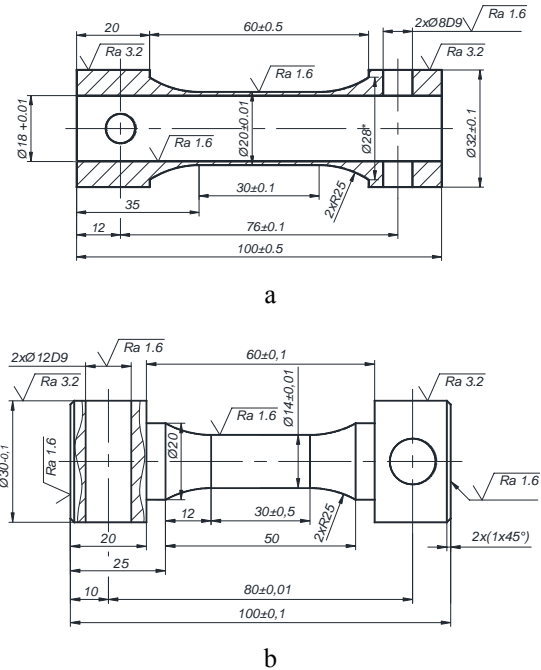

Fig. 1 Specimen for monotonic and low cycle torsion: a – hollow, b – solid

For the monotonic and low cycle symmetric torsion experiments the tubular shape specimens with  $t/d = 1/20$  working part were used. The specimens were made of grade 45 steel rod, following the dimensions shown in Fig. 1, a. During the cyclic torsion in the wall of the tubular specimen is uniform stress state, i.e. there is no influence of the stress gradient. The working part of the specimen ( $l = 30$  mm) was chosen taking into account the previously used torsion specimens. The fillet radius while passing into the working part of the specimen, was  $R = 25$  mm, aiming to decrease the stress concentration to minimum (the theoretical stress ratio  $\alpha_\sigma \approx 1.03$ ). For the asymmetric low cycle torsion experiments the solid circular cross-section specimens have been used. All specimens were made of the same grade 45 steel rod following the dimensions presented in the Fig. 1, b.

To determine the torque  $T$ , the resistance wire gauges were glued on the surface of the tenzometer device with cylindrical working part  $d = 18.0$  mm. The tenzometer device was made of thermal treatment grade 60S2A spring steel (HRC 42-45). The working strain gauges were glued to the cylinder's surface along the main strain directions  $e_1$  and  $e_3$  (at  $45^\circ$  angle, in opposite sides).

Table 1

Mechanical characteristics of grade 45 steel

Series	$\tau_{pr}$ , MPa	$\tau_{0.3}$ , MPa	$\tau_{0.2}$ , MPa	$\gamma_{0.2}$ , %
1	174	226	4245	23.4
2	224	209	435	25.2
3	188	211	420	19.7
Mean				
$\bar{x}$	195	215	426	22.7

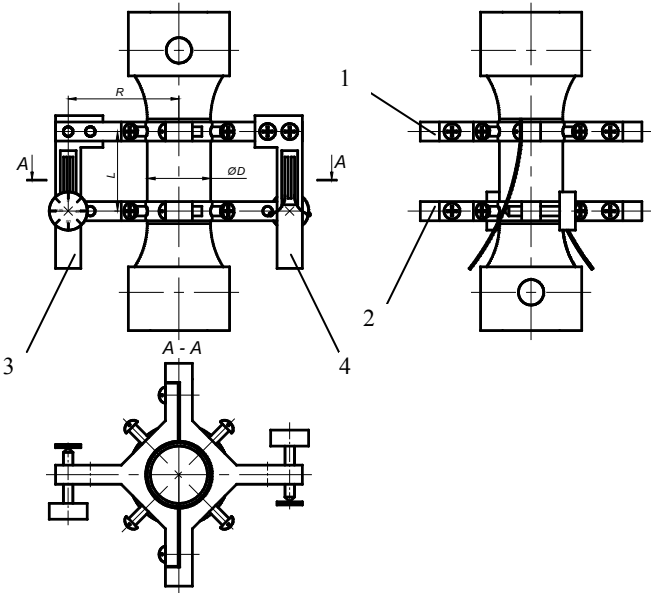

Fig. 2 Tenzometer for torsion angle measurements

The torsion strain is measured by the attachment, which identifies torsion angle  $\varphi$  in the working part of the specimen. The device for torsion angle measurements, presented in Fig. 2, consists of two rings 1 and 2, each of them has bolt fastened half rings, that are attached to the specimen by means of the 4 conical tip bolts, locating them at identical angles. Two spring steel plates 3 and 4 are fastened to the top ring. Working gauges ( $R = 100 \Omega$ ) are glued along tension-compression sides of the plates. Free end of each plate rests on bolt-adjusted bottom retainer ring. During torsion of the specimen, the rings turn relative to each other and sprung steel plates act as cantilever rods during bending [9].

### 3. Experimental analysis

#### 3.1 Monotonic loading

During the monotonic torsion experiments the monotonic torsion curve was defined. The monotonic torsion curve in  $\tau_{max} - \gamma_{max}$  coordinates is shown in Fig. 3. The defined mechanical characteristics of grade 45 steel under torsion are presented in Table 1.

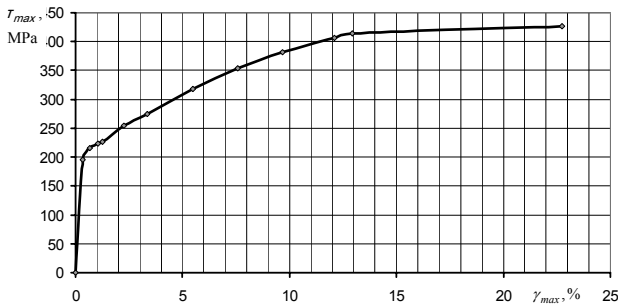

Fig. 3 Monotonic torsion curve

#### 3.1 Asymmetric low cycle loading

It was mentioned earlier, that in real constructions most common is the asymmetric loading, which results that hysteresis loop's width  $\bar{\delta}_k$  is highly dependent on the stress

ratio  $r_\sigma$ . Fig. 4 shows the stress amplitude dependence both on the mean stress and the stress ratio [7].

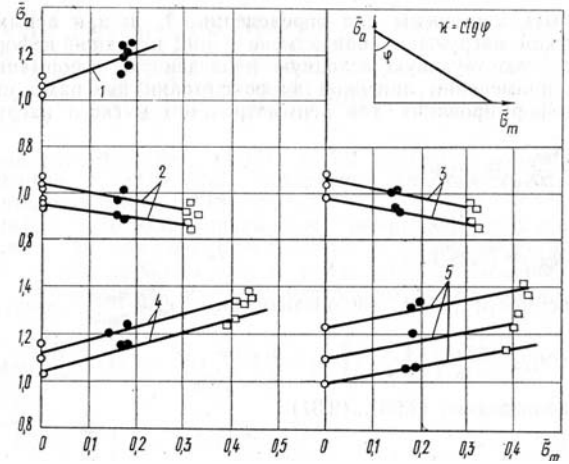

Fig. 4 Stress amplitude dependence both on the mean stress and stress ratio  $r_\sigma$ , when  $\delta_1 = const$ : 1 – grade D16T1 aluminium alloy; 2,3 – grade 15Ch2MF steel after thermal treatment and tempering; 4,5 – delivered state grade 45 steel;  $\circ - r_\sigma = -1.0$ ;  $\bullet - r_\sigma = -0.75$ ;  $\square - r_\sigma = -0.5$

The hysteresis loop's width  $\bar{\delta}_k$  of the semicycles depends both on the stress amplitude  $\bar{\sigma}_a$  and mean stress  $\bar{\sigma}_m$ . These equations and the method for their determination (Fig. 4) have been used in research works of M. Daunys, H. Medekšas and R. Šneiderovic to calculate the results of tension-compression experiments [1, 7, 8]. Thus this dependence may be written

$$\bar{\sigma} = -tg(90 - \varphi)\bar{\sigma}_m + \bar{\sigma}_a \quad (1)$$

or

$$\bar{\sigma} = ctg\varphi\bar{\sigma}_m + \bar{\sigma}_a \quad (2)$$

and introducing the notations  $ctg\varphi = \kappa$  and  $\bar{\sigma} = \bar{\sigma}_{con}$ , the following is obtained

$$\bar{\sigma}_{con} = \bar{\sigma}_a + \kappa\bar{\sigma}_m \quad (3)$$

where  $\bar{\sigma}_{con}$  is conditional stress.

For symmetric cycle,  $\bar{\sigma}_m = 0$  and results

$$\bar{\sigma}_{con} = \bar{\sigma}_a = \bar{\sigma} \quad (4)$$

While using the earlier mentioned equations, the experimental results, despite the stress ratio in coordinates

$\bar{e}_{con} - \bar{\delta}_1$  are coincident with the results of the symmetric cycle and the following may be written

$$\bar{\delta}_k = A_{1,2} \left( \bar{e}_{con_{1,2}} - \frac{\bar{s}_T}{2} \right) \quad (5)$$

To simplify the calculations, it was taken, that cyclic proportional limit  $\bar{s}_T$  is independent on  $\bar{e}_{con}$  [1], the number of semicycles  $k$  and on stress ratio  $r_\sigma$ . Therefore, for the asymmetrical cycle, in all the equations used for the symmetrical cycle, the initial strain  $\bar{e}_0$  is replaced by  $\bar{e}_{con}$ , which is defined from the monotonic diagram by  $\bar{\sigma}_{con}$ .

For anisotropic materials, two parameters  $\kappa_1$  for uneven and  $\kappa_2$  for even semicycles and consequently  $\bar{e}_{con_1}$  for uneven and  $\bar{e}_{con_2}$  for even semicycles. These parameters characterize the dependence of the strain diagrams on the stress ratio  $r_\sigma$  [8].

The experiments were carried out under negative asymmetric loading cycles. The cycles were corresponding to loading of the real constructions and the following stress ratio were chosen:  $r_\tau = -0.75$  and  $r_\tau = -0.5$ .

The experiments of the asymmetric low cycle torsion were carried out under constant hysteresis loop's width of the first semicycle ( $\bar{\delta}_1 = const$ ). The calculated amplitude stress dependence both on the mean stress and the stress ratio  $r_\sigma$  is shown in Fig. 5.

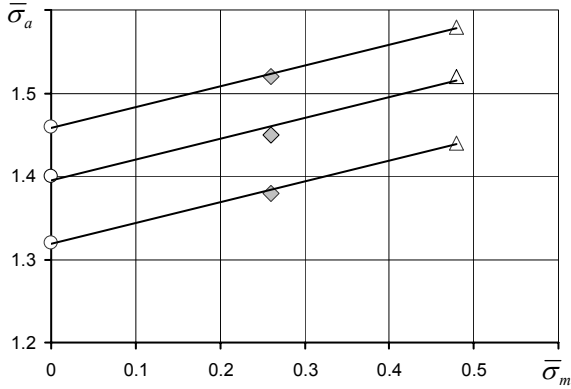

Fig. 5 Calculated amplitude stress dependence both on the mean stress and the stress ratio  $r_\sigma$ ;  $\delta_1 = const$  for grade 45 steel;  $\circ - r_\sigma = -1.0$ ;  $\diamond - r_\sigma = -0.75$ ;  $\Delta - r_\sigma = -0.5$

From the Eq. (2), as  $r_\sigma = \frac{\sigma_{min}}{\sigma_{max}}$ , we can express

$$p_{1,2} = 1 + \kappa_{1,2} \frac{1+r_\sigma}{1-r_\sigma} \quad (6)$$

where

$$\bar{\sigma}_{con_{1,2}} = \bar{\sigma} p_{1,2} = \bar{\sigma}_a p_{1,2} \quad (7)$$

During the symmetric ( $r_\tau = -1.0$ ) and asymmetric stress-limited torsion experiments under stress ratio

( $r_\tau = -0.75$  and  $r_\tau = -0.5$ ), the hysteresis loop's width dependence on the number of loading semicycles  $k$  was determined. Fig. 6 shows, that as the number of the loading semicycles  $k$  increases, for grade 45 steel, the loop width  $\bar{\delta}_k$  remains constant, thus we have a cyclic stable material.

Where

$$\bar{\tau}_0 = \frac{\tau_0}{\tau_{pl}}; \bar{\delta}_k = \frac{\delta_k}{\gamma_{pl}} \quad (8)$$

here  $\tau_0$  is shear stress at the initial semicycle,  $\tau_{pl}$  and  $\gamma_{pl}$  are the stress and strain of proportional limit under torsion.

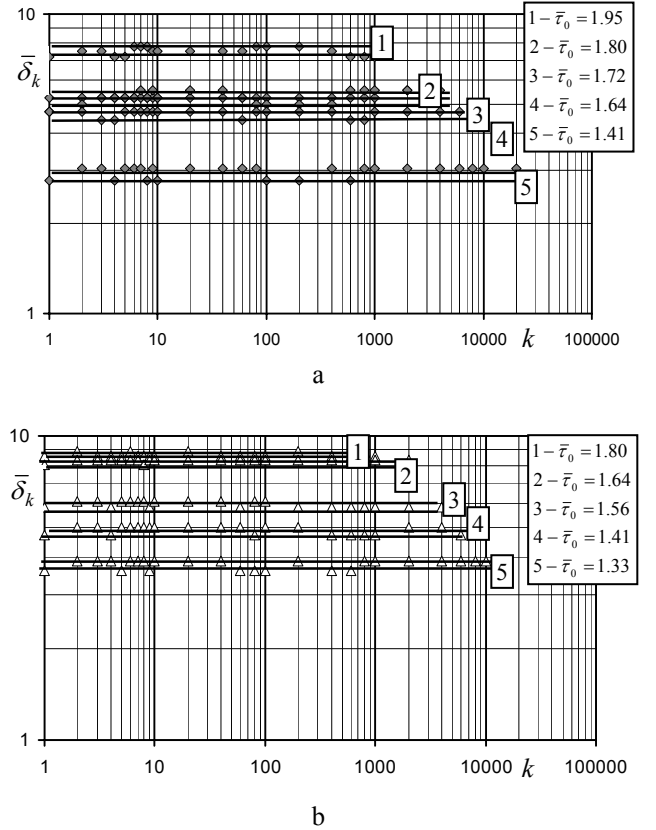

Fig. 6 Dependence of hysteresis loop width both on the number  $k$  of the loading semicycles and loading level  $\bar{\tau}_0$  for solid specimens made of grade 45 steel under low cycle torsion:  $a - r_\tau = -0.75$  ( $\bar{\delta}_1, \bar{\delta}_2$ );  $b - r_\tau = -0.5$  ( $\bar{\delta}_1, \bar{\delta}_2$ )

Table 2  
Cyclic characteristics of the grade 45 steel

Hollow specimens, $r_\tau = -1.0$			Solid specimens, $r_\tau = -1.0$		
$A$	$\bar{s}_T$	$\alpha$	$A$	$\bar{s}_T$	$\alpha$
1.1	1.40	0	1.1	1.40	0
Solid specimens, $r = -0.75$					
$A_1$	$A_2$	$\bar{s}_T$	$\alpha$	$\kappa_1$	$\kappa_2$
0.51	0.55	1.45	0	-0.25	-0.26
Solid specimens, $r_\tau = -0.5$					
$A_1$	$A_2$	$\bar{s}_T$	$\alpha$	$\kappa_1$	$\kappa_2$
0.23	0.29	1.40	0	-0.25	-0.26

During the experiments of the low cycle asymmetrical torsion, differently than under symmetrical torsion, it was determined, that grade 45 steel accumulates plastic strain along the initial torsion direction (Fig. 7, a, b). Then the accumulated plastic strain in initial torsion direction after  $k$  loading semicycles is calculated as follows

$$\bar{e}_{pk} = \bar{e}_0 - \bar{\sigma}_0 + \sum_1^k (-1)^k \bar{\delta}_k \quad (9)$$

where  $\bar{\sigma}_0$  is stress of the initial semicycle.

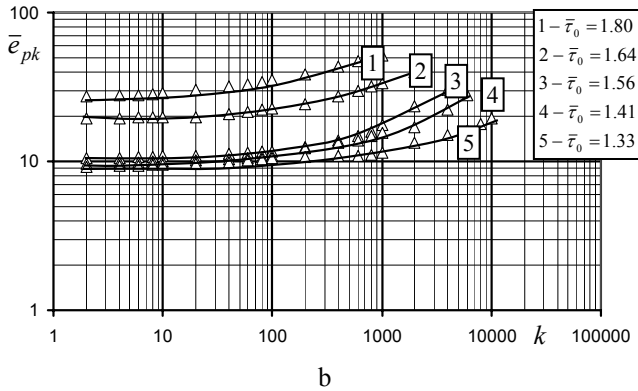
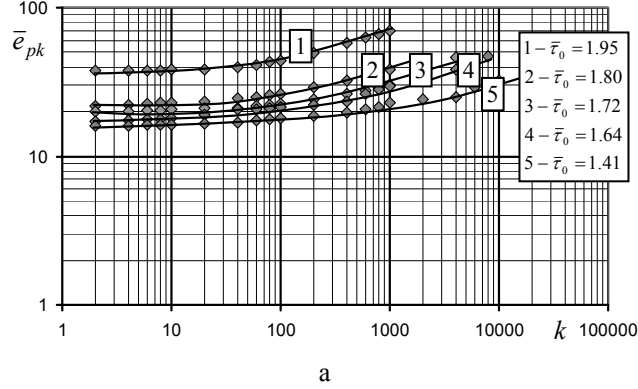

Fig. 7 Curves of the accumulated plastic strain till crack initiation for solid specimens of grade 45 steel under low cycle torsion: a –  $r_\tau = -0.5$ ; b –  $r_\tau = -0.75$

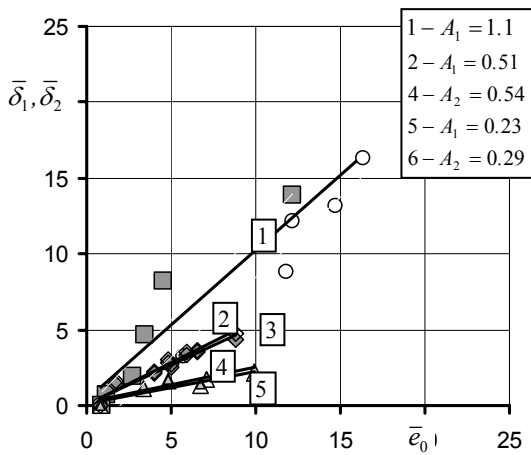

Fig. 8 Loop width dependences of first and second semicycles on the conditional initial stress for grade 45 steel under low cycle torsion: 1 – hollow and solid specimens  $A_1$  ( $r_\tau = -1.0$ ); 2,3 – solid specimens  $A_1, A_2$  ( $r_\tau = -0.75$ ); 4,5 – solid specimens  $A_1, A_2$  ( $r_\tau = -0.5$ )

Loop width dependences of the first and second semicycles on the conditional initial strain are presented in Fig. 8. The defined cyclic characteristics of the material are given in Table 2.

#### 4. Accumulated damage under stress-limited loading

Thus, the specimen under stress limited torsion fractures due to quasistatic damage  $d_K$ , caused by the accumulated plastic strain  $\bar{e}_{pk}$ , and due to fatigue damage  $d_N$ , resulted by the cyclic plastic strain, which is characterized by the hysteresis loop's width  $\bar{\delta}_k$ . Therefore total damage  $d$  may be written

$$d = d_K^q + d_N^l \quad (10)$$

Fatigue damage is calculated using the following equation

$$d_N = \frac{\sum_1^k \bar{\delta}_k}{\sum_1^{k_c} \bar{\delta}_k} \quad (11)$$

where  $\sum_1^k \bar{\delta}_k$  is fatigue damage accumulated during  $k$  loading semicycles,  $\sum_1^{k_c} \bar{\delta}_k$  is fatigue damage accumulated till the crack initiation.

Quasistatic damage

$$d_K = \frac{\bar{e}_{pk}}{\bar{e}_{u_2}} \quad (12)$$

where  $\bar{e}_{pk}$  is accumulated plastic strain after  $k$  loading semicycles, whereas  $\bar{e}_{u_2}$  is uniform strain under monotonic loading.

The analytical curves of the cyclically stable grade 45 steel, as only fatigue damage is taken into account, were calculated applying the following equation [7, 9, 10]

$$\frac{\bar{\delta}_1 \cdot \bar{\epsilon}_1^{\alpha_3}}{C_2 \cdot C_3^{\alpha_3}} + \frac{\bar{\delta}_2 \cdot \bar{\epsilon}_2^{\alpha_3}}{C_2 \cdot C_3^{\alpha_3}} + \dots + \frac{\bar{\delta}_{k_c} \cdot \bar{\epsilon}_{k_c}^{\alpha_3}}{C_2 \cdot C_3^{\alpha_3}} = 1 \quad (13)$$

Table 3 presents characteristics of the Coffin's curves  $C_2, C_3, m_1, m_2, m_3$ , which were obtained from the experimental data [9] for the grade 45 steel under low cycle strain limited torsion loading.

Table 3

Values of Coffin's constants  $C$  and  $m$

$C_2$	$C_3$	$m_1$	$m_2$	$m_3$
727	440	0.49	0.58	0.88

Fig. 9 shows graphical relationship between the quasi-static and fatigue damage for the analysed grade 45 steel under different stress ratio. The mentioned figure in-

indicates, that Eq. (10) constants are  $q = l = 1$ , whereas damage accumulation by using Eqs. (10)-(12) is presented in Table 4.

It is seen from Fig. 9 and Table 4, that under asymmetric loading the quasistatic damage depends on the stress level and is increased at highest loading levels ( $r_{\tau} = -0.75$ , when  $\bar{\tau} = 1.80 - 70.6\%$ ;  $r_{\tau} = -0.5$ , when  $\bar{\tau} = 1.95 - 82.2\%$ ). When stress level decreases, the part of quasi-static damage also decreases ( $r_{\tau} = -0.75$ , when  $\bar{\tau} = 1.33 - 27.8\%$ ;  $r_{\tau} = -0.5$ , when  $\bar{\tau} = 1.41 - 48.1\%$ ).

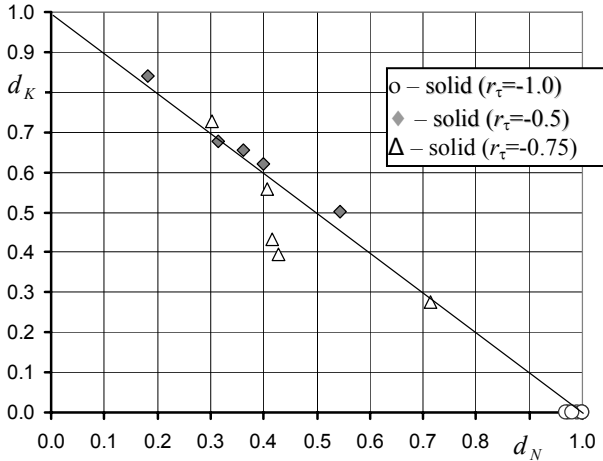

Fig. 9 Quasistatic and fatigue damage relation under stress limited symmetric and asymmetric loading

Table 4

Accumulated damage under asymmetric loading

Solid specimens, $r_{\tau} = -0.75$					
$\bar{\tau}$	1.80	1.64	1.56	1.41	1.33
$d_N$	0.303	0.406	0.416	0.428	0.715
$d_K$	0.728	0.559	0.432	0.395	0.275
$d$	1.031	0.966	0.847	0.823	0.990
Solid specimens, $r_{\tau} = -0.5$					
$\bar{\tau}$	1.95	1.80	1.72	1.64	1.41
$d_N$	0.182	0.314	0.362	0.400	0.544
$d_K$	0.839	0.678	0.656	0.622	0.503
$d$	1.021	0.992	1.018	1.022	1.047

Fig. 10 shows the experimental low cycle fatigue curves for symmetric and asymmetric cycles and also the fatigue curves, as only fatigue damage is taken into account. It is seen from this figure, the same as from the Table 4, that quasistatic damage more significant decrease in the fatigue life under higher strain level. At medium loading levels, when  $\bar{\tau} = 1.60$  and asymmetry  $r_{\tau} = -0.75$ , the experimental curves show, that fatigue life, if compared to the theoretical fatigue curves, diminishes from  $N_c = 2840$  to  $N_c = 1830$  cycles. Under the same loading level  $\bar{\tau} = 1.60$  and asymmetry  $r_{\tau} = -0.5$ , results decrease in fatigue life from  $N_c = 9050$  to  $N_c = 5010$  cycles.

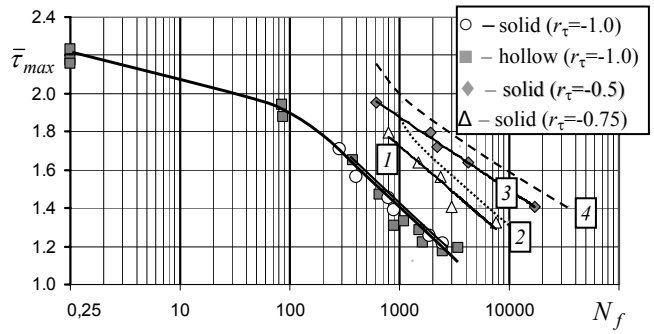

Fig. 10 Experimental curve for grade 45 steel under stress-limited asymmetric loading ( $r_{\tau} = -0.75$ ;  $-0.5$ ): low cycle ( $r_{\tau} = -0.75$ ) fatigue curves (1) compared to theoretical (2), as only fatigue damage is taken into account, low cycle ( $r_{\tau} = -0.5$ ) fatigue damage (3) compared to theoretical (4), as only fatigue damage is taken into account

## 5. Conclusions

Grade 45 steel under stress-limited monotonic torsion, low cycle symmetric and asymmetric torsion loading was analysed, using hollow and solid specimens of the circular cross-section.

1. It was determined that for the analysed grade 45 steel the hysteresis loop width is independent on the number of the loading semicycles  $k$  under symmetric ( $r_{\tau} = -1.0$ ) and asymmetric ( $r_{\tau} = -0.75, -0.5$ ) torsion, i.e. this steel is cyclically stable and parameter  $\alpha = 0$ .

2. Under the asymmetric loading, when stress ratio are  $r_{\tau} = -0.75$  and  $r_{\tau} = -0.5$ , the accumulation of the plastic strain in the direction of the initial loading, which does not occur during the symmetric loading cycle was determined.

3. The analysed case of the symmetric loading showed smaller fatigue life if compared to that of the asymmetric loading, whereas under asymmetric loading, due to the accumulation of plastic strain, the quasistatic damage occurs, which reduces the fatigue life at the highest levels of loading ( $r_{\tau} = -0.75$ , as  $\bar{\tau} = 1.80 - 70.6\%$ ;  $r_{\tau} = -0.5$ , when  $\bar{\tau} = 1.95 - 82.2\%$ ) and at low levels of loading ( $r_{\tau} = -0.75$ , as  $\bar{\tau} = 1.33 - 27.8\%$ ;  $r_{\tau} = -0.5$ , when  $\bar{\tau} = 1.41 - 48.1\%$ ).

## References

1. **Daunys, M.** Strength and Fatigue Life under Low Cycle Non-Stationary Loading. -Vilnius: Mokslas, 1989. - 256p. (in Russian).
2. **Krenevičius, A., Juchnevičius, Ž.** Load distribution in the threaded joint subjected to bending. -Mechanika. -Kaunas: Technologija, 2009, No.4(78), p.12-16.
3. **Djakov, I., Prentkovskis, O.** Optimization problems in designing automobiles. -Transport. -Vilnius: Technika, 2008, vol.23, No.4, p.316-322.
4. **Kala, Z., Melcher, J., Puklický, L.** Material and geometrical characteristics of structural steels based on statistical analysis of metallurgical products. -Journal of civil engineering and management. -International re-

- search and Achievements. -Vilnius: Technika, 2009, vol.15, No.3, p.299-307.
5. **Gasiak, G., Pawliczek, R.** Application of an energy model for fatigue life prediction of construction steels under bending, torsion and synchronous bending and torsion. -International Journal of Fatigue 25. -Elsevier, 2003; p.1339=1346.
  6. **Bražėnas, A., Vaičiulis, D.** Determination of stresses and strains in two-layer mechanically inhomogeneous pipe subjected to internal pressure at elastic plastic loading. -Mechanika. -Kaunas: Technologija, 2009, No.6(80), p.12-17.
  7. **Daunys, M.** Cycle Strength and Durability of Structures. -Kaunas: Technologija, 2005. -286p. (in Lithuanian).
  8. **Medekšas, H.** Strength and fracture under low cycle loading at elevated temperatures: summary: mechanics thesis for degree of Doctors of habilitation. -Kaunas: Technologija, 1994.-25p.
  9. **Daunys, M., Česnavičius, R.** Low cycle stress strain curves and fatigue under tension-compression and torsion. -Mechanika, -Kaunas: Technologija, 2009, No.6(80), p.5-11.
  10. **Daunys, M., Rimovskis, S.** Analysis of circular cross-section element, loaded by static and cyclic elastic-plastic pure bending. -International Journal of Fatigue. -Elsevier, 2006, 28, p.211-222.

M. Daunys, R. Česnavičius

#### MAŽACIKLIO ASIMETRINIO SUKIMO TYRIMAS

##### Reziumė

Straipsnyje nagrinėjamas plieno 45, apkrauto simetriniu ( $r_r = -1.0$ ) ir asimetriniu ( $r_r = -0.75; -0.5$ ) sukimu, mažaciklis nuovargis esant apribotiems šlyties įtempiams. Nustatyta, kad medžiaga yra cikliškai stabili, nes histerezės kilpos plotis tiek simetrinio, tiek asimetrinio apkrovimo atveju yra pastovus. Esant simetriniam ciklui, vienpusė plastinė deformacija nekaupiama, t. y. nėra kvazistatinių pažeidimų, o asimetrinio apkrovimo metu ima kauptis vienpusė plastinė deformacija. Pasiūlytos analitinės priklausomybės apskaičiuoti ilgalaikiškumui, esant asimetriniam apkrovimui, įvertinant sukauptos vienpusės plastinės deformacijos sukeltus nuovarginius ir kvazistatinius pažeidimus. Nustatyta, kad kvazistatiniai pažeidimai didėja, didėjant apkrovimo lygiui ir, esant vidutiniams apkrovimo lygiams, ilgalaikiškumas sumažėja nuo  $N_c = 2840$  iki  $N_c = 1830$  ( $\bar{\tau} = 1.60; r_r = -0.75$ ) ir nuo  $N_c = 9050$  iki  $N_c = 5010$  ( $\bar{\tau} = 1.60; r_r = -0.5$ ).

M. Daunys, R. Česnavičius

#### INVESTIGATION OF LOW CYCLE ASYMMETRIC TORSION

##### Summary

The presented paper considers low cycle fatigue of the grade 45 steel under symmetric ( $r_r = -1.0$ ) and asymmetric ( $r_r = -0.75; -0.5$ ) stress limited torsion. It was defined, that the material is cyclically stable, because the hysteresis loop width during symmetric and asymmetric loading cycles is constant. Under the symmetric cyclic loading, the plastic strain is not accumulated, i.e. quasi-static damage does not occur, whereas under the asymmetric loading the accumulation of plastic strain takes place. The analytical dependences were proposed to calculate the fatigue life under asymmetric loadings, taking into account the fatigue and quasi-static damage due to accumulated plastic strain. It was determined, that quasi-static damage increases, while loading level increases and results at the middle levels decrease of the fatigue life from  $N_c = 2840$  to  $N_c = 1830$  ( $\bar{\tau} = 1.60; r_r = -0.75$ ) and from  $N_c = 9050$  to  $N_c = 5010$  ( $\bar{\tau} = 1.60; r_r = -0.5$ ).

М. Даунис, Р. Чеснавичюс

#### ИССЛЕДОВАНИЕ МАЛОЦИКЛОВОГО АСИМЕТРИЧНОГО КРУЧЕНИЯ

##### Резюме

В статье рассматривается малоцикловое кручение стали 45 при симметрическом ( $r_r = -1.0$ ) и асимметрическом ( $r_r = -0.75; -0.5$ ) циклах мягкого нагружения. Установлено, что исследуемая сталь является циклически стабильным материалом, так как ширина петли упругопластического гистерезиса является постоянной как при симметрическом, так и при асимметрическом нагружениях. При симметричном нагружении накопление односторонней пластической деформации отсутствует, а при асимметричном нагружении эта деформация накапливается. Предложены аналитические зависимости для расчета долговечности при асимметричном нагружении, учитывая усталостные и квазистатические повреждения, инициированные односторонней пластической деформацией. Определено, что квазистатические повреждения увеличиваются при увеличении уровня мягкого нагружения и при средних уровнях уменьшают долговечность от  $N_c = 2840$  до  $N_c = 1830$  ( $\bar{\tau} = 1.60; r_r = -0.75$ ) и от  $N_c = 9050$  до  $N_c = 5010$  ( $\bar{\tau} = 1.60; r_r = -0.5$ ).

Received August 30, 2010

Accepted December 07, 2010

DOI: 10.5755/j02.mech.15968