

Computational analysis of the magnetorheological fluid loading unit of rowing simulator

V. Grigas*, K. Kazlauskienė**, A. Šulginas***, R.T. Toločka****

*Kaunas University of Technology, A. Mickevičiaus 37, 44244 Kaunas, Lithuania, E-mail: vytautas.grigas@ktu.lt

**Kaunas University of Technology, A. Mickevičiaus 37, 44244 Kaunas, Lithuania, E-mail: kristina.kazlauskiene@ktu.lt

***Kaunas University of Technology, A. Mickevičiaus 37, 44244 Kaunas, Lithuania, E-mail: toskai@gmail.com

****Kaunas University of Technology, A. Mickevičiaus 37, 44244 Kaunas, Lithuania, E-mail: tadas.tolocka@ktu.lt

1. Introduction

The area of implementation of modern technologies and materials (like a smart fluids [1]) expands constantly. Thus the usage of magnetorheological fluid (MRF) technology [2], which has started from automotive applications [3], spreaded on such objects as intelligent prosthesis [4] or sports equipment [5]. The training facility for academic rowers is under discussion of this paper.

A lot of different rowing machines are built for exercising at home, in sports clubs and for preparing high-level sportsmen. In the simplest ones the weight stack or the mass of the athlete is used to generate the resisting force acting the levers simulating the oars, in more sophisticated – rotational or linear motion magnetic, inertial/pneumatic or hydraulic loading units are employed. In all cases one of the most technical problems is the reproduction of the physics of rowing, i.e. the rowing kinematics and the pattern of resistant force, because these factors have quite large influence on rowing performance [6-11]. Therefore when the weight stack or similar simple rowing machine is suitable enough for maintaining general physical condition, professional athletes prefer improving their physical abilities and technique by rowing a boat fixed in the pool [12, 13]. In this case the kinematics of rower movements and the variation of force conforms the real rowing, but such equipment seems to be too cumbersome and too expensive (especially when there is a need to train in the sports club or at home). For such purposes a more acceptable solution of the problem is offered by well known rowing simulators “Concept2” [14] or “Rowperfect” [15]: “Rowperfect is the first rowing machine to accurately reproduce the physics of the rowing. Whether you are a World Championship aspirant or a non rower who just wants to get fit fast – and stay that way – the Rowperfect rowing machine represents the safest and the most effective way to get there”. They are widely used by advanced sportsmen in general and in a great request among the rowers. Again, they are often of service during the research of rowing process [16, 17].

However the law of change of the resistant force, generated by machines in use, is still not the same, as when rowing in the water – there are discrepancies [8]. Thus the research has been initiated having the aim to develop a controllable loading unit, able to ensure the law of the resisting force on the handle of simulator as much as possible close to real. Some attempts made before led to quite simple but not plausible solutions, so this paper presents the results of the further investigations.

2. Controllable hydraulic loading unit for rowing simulator

The controllable hydraulic loading unit for academic rowing simulator has been proposed earlier by the authors which is able to generate the chosen (programmed) pattern of the rowing force, dependent on various parameters, including rower strength, intensity of rowing, velocity of the boat, etc. [6-11]. A stationary rotational hydraulic cylinder (square cross-section) in which two chambers are separated by movable diaphragm having the channel, connecting them, is used for generating of the resistant force on the handle of the oar, connected to the diaphragm (Fig. 1, a). The control of the force on the oar handle is ensured by the computerized system equipped with the oar position and velocity sensors and proportional flow control valve *FCV* (Fig. 1, b), regulating the cross-section area of the channel made in hydraulic cylinder depending on the position and the velocity of the oar $s = f(\varphi, \dot{\varphi})$ [18, 19].

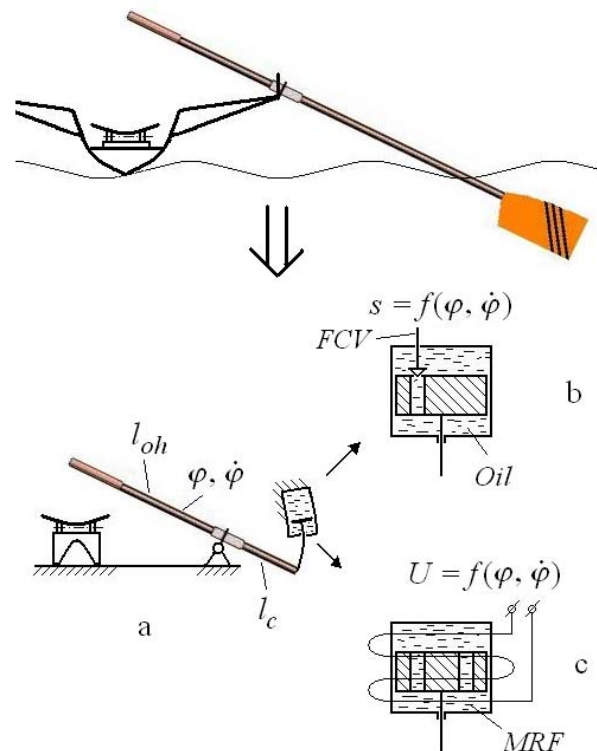

Fig. 1 Rowing simulator loading unit with the controllable resisting force: $\varphi, \dot{\varphi}$ are angular position and velocity of the oar handle; l_c is lever arm of the rotational cylinder diaphragm; l_{oh} is lever arm of the oar handle

When developing this loading unit its simplified (straightened) 3D geometrical model has been created by means of SolidWorks 3D CAD software and basing on it the dependence of the size of resisting force on the velocity of movement of the diaphragm in the cylinder at a constant diaphragm channel cross-section area was derived by means of computational hydrodynamic analysis, performed by using CosmosFloWorks CFD (computational fluid dy-

namics) software. The inversion principle was utilized during computations: the fluid flow of determined velocity through the channel in unmovable diaphragm was analyzed. It means that the force, arising due to hydrodynamic pressure of the fluid acting on the diaphragm was computed at different velocities of flow, corresponding the velocity of movement of diaphragm in the cylinder (Fig. 2).

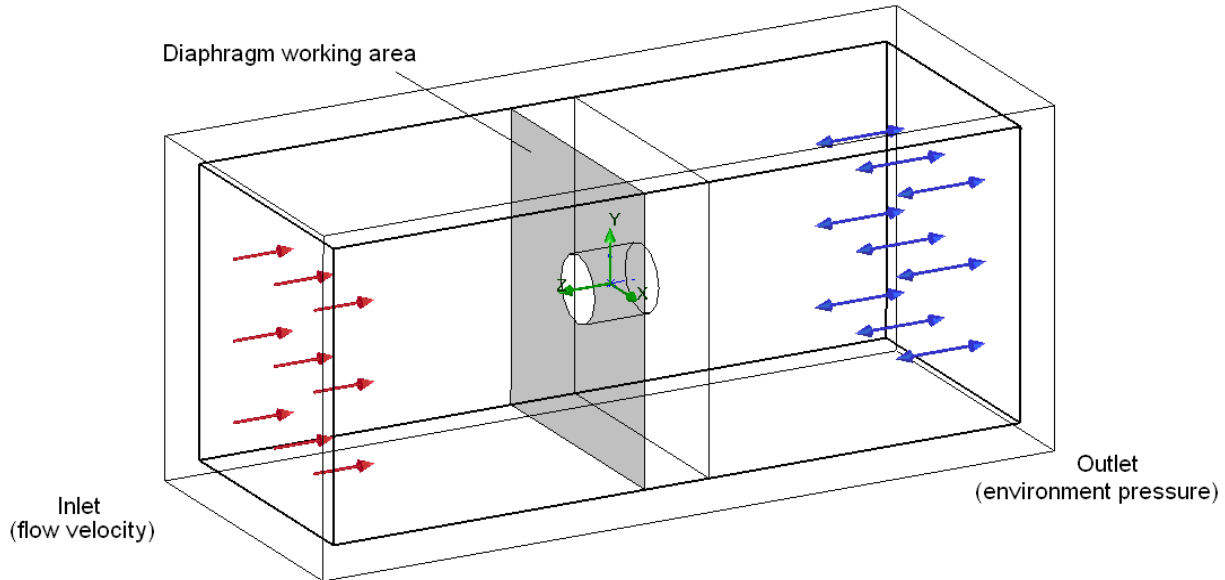

Fig. 2 Simplified computational model of the rowing simulator controllable loading unit hydraulic cylinder

By combining the results of experimental measurement of the academic rowing kinematic parameters (oar angular velocity during rowing stroke or the corresponding linear velocity of the diaphragm) and the data obtained by means of computational hydrodynamic analysis of resisting force generated by the loading unit at corresponding velocity of the flow), the law of resisting force generated by the unit at a constant diaphragm channel cross-section area was derived. Subsequently the law of change of this parameter leading to superposing the laws of resisting forces (measured when exercising on an academic (sculling) rowing simulator in the pool and generated by loading unit) was obtained [20].

Thus the ability of proposed scheme to realize idea of the quite simple mechanical control of the resisting force on the oar handle of rowing simulator has been proved. However, the rapidity of rowing process raises doubts about plausibility of such approach due to possible heaviness of hydraulic system. That is why the further step in improvement of the loading unit of the academic rowing simulator has been taken – an attempt to build the system, where the control of the force generated by loading unit is realized in completely different way: instead of controlling the force on simulators oar handle by means of changing the cross-section area of the channel in the diaphragm between the chambers of hydraulic cylinder, the variation of the viscosity of the magnetorheological working fluid flowing through the channel between the chambers of the hydraulic cylinder is offered (*MRF*, Fig. 1, c). In this case the cross-section area of the channel in the diaphragm separating these chambers remains constant, so the proportional flow control valve (*FCV*, Fig. 1, b) is now expendable.

3. Magnetorheological fluid loading unit

Having the aim to evaluate the possibility to realize MRF technology in the existing hydraulic loading unit of the academic rowing simulator (or replace it without significant changes of simulator) a computational finite element analysis of the MRF through the diaphragm connecting the chambers of loading unit and a resultant hydrodynamic force, acting the surface of the diaphragm has been performed. The first approach was also intended to find out, if it is possible to obtain the necessary range of resistant force, which should be 200-10000 N in order to ensure 20-1000 N force on simulator oar handle due to the ratio of arms $l_c / l_{oh} = 1/10$ (Fig. 1, a) (maximal – during drive stroke, minimal – during recovery).

The computations, in general very similar to those described in section 2, were performed by means of the SolidWorks Flow Simulation CFD software. The geometrical and computational models were practically the same, as mentioned above. The only difference was the properties of the fluid – they were described adequate to the properties of magnetorheological fluid MRF-140CG (minimal dynamic viscosity – 0.28 Pa s [21], maximal dynamic viscosity – 70 Pa s [22]), this way achieving a possibility to manipulate this parameter during the computations and to identify the dependence of the size of hydrodynamic force, acting the working surface of the diaphragm, upon the velocity of the flow of fluid having different viscosity. The finite element mesh (~17000 fluid cells, ~ 9000 partial cells) of MRF loading unit, corresponding the computational model, presented on Fig. 2, is shown on Fig. 3.

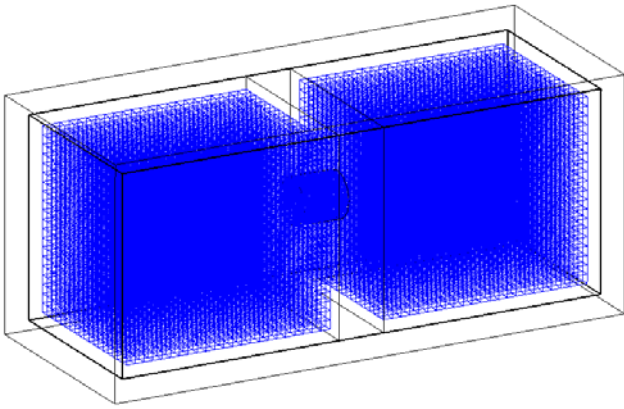

Fig. 3 Finite element model of MRF loading unit (fluid cells only)

The internal fluid flow computational analysis was carried out at the following parameters:

- cross-section of the cylinder (diaphragm working area) 55x60 mm;
- working liquid flow velocity range 0.05 - 0.25 m/s with 0.05 m/s step;
- initial temperature 200°C;
- channel wall roughness 0,05 mm;
- viscosity of the fluid 0.28-70 Pa·s;
- hydrodynamic force on the diaphragm working surface – 200-10000 N.

At first a set of initial computations with different values of the fluid viscosity and configurations of the channel between chambers has been performed (Fig. 4, a) having the aim to find out if it is possible to obtain the necessary range of force acting diaphragm working area (approximately from 20 to 1000 N [18, 19]).

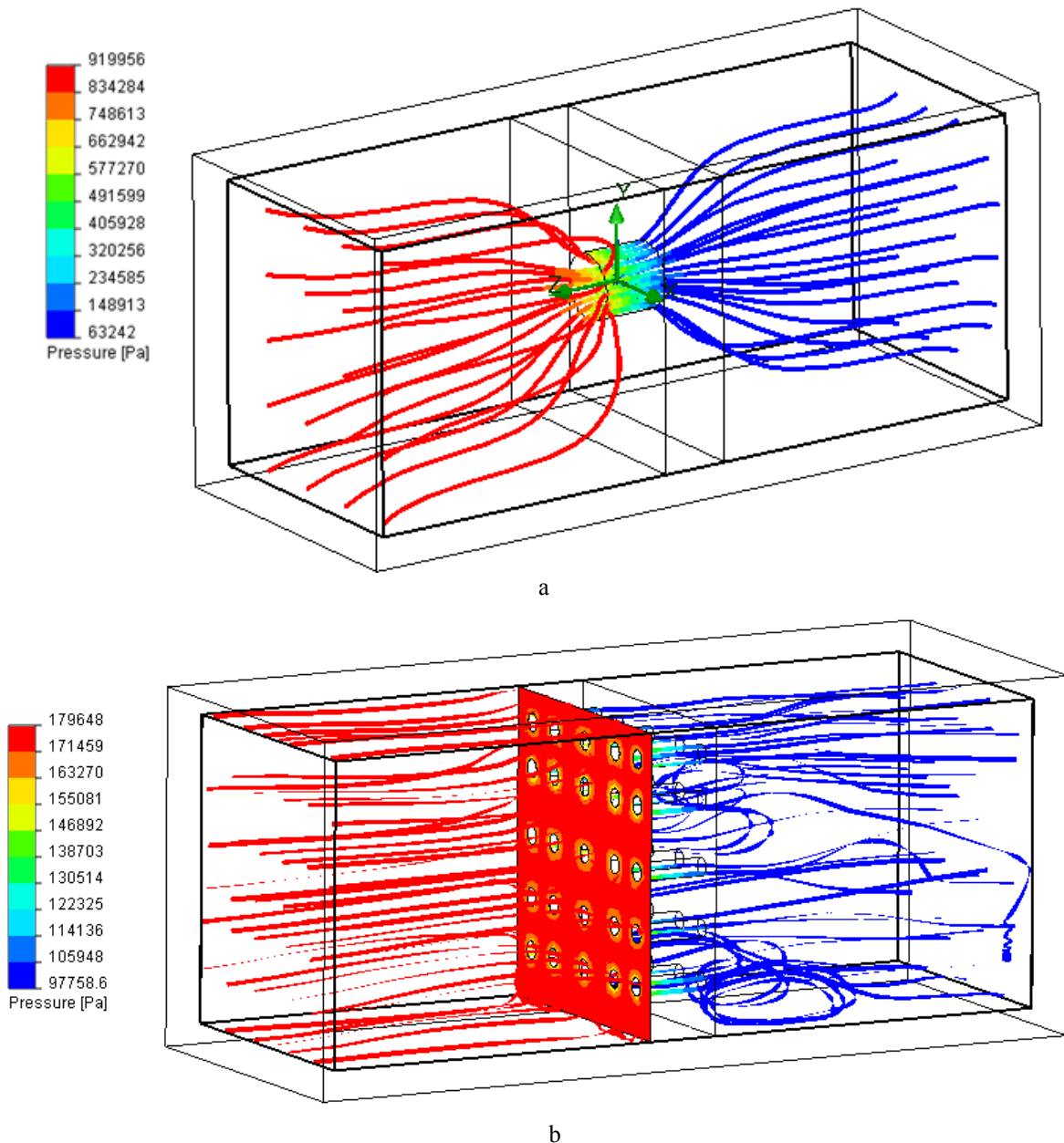

Fig. 4 Flow trajectories and pressure distribution of the magnetorheological fluid MRF-140CG (dynamic viscosity 0.5 Pa s), flow (velocity 0.2 m/s) through the diaphragms having 1 (a) and 25 (b) round channels connecting the chambers of loading unit

The problem is that the maximal velocity of the oar (and the flow in the cylinder) during recovery phase is slightly larger, than the velocity during drive stroke (0.2 and 0.15 m/s correspondingly), meanwhile the force should be, in opposite, maximal in drive stroke, and almost intangible during recovery, so in the first case the viscosity should be increased to receive higher value of the force, and in the second – reduced to minimum to obtain minimal value.

It was found out, that the minimal, 200 N force (for recovery phase, flow velocity – 0.2 m/s), can be obtained when the diameter of the round channel in the diaphragm is 14 mm (when the viscosity of the fluid is minimal, 0.28 Pa s). But in this case increasing the viscosity up to its maximal value (70 Pa s) gives only 2240 N force of at 0.15 m/s flow velocity (drive phase), what is 4 times lower value than required 10000 N. The situation is opposite when the diameter of the channel is reduced to the value, which gives the necessary maximal force during drive phase (flow velocity 0.15 m/s, viscosity 70 Pa s) – i.e. 9.3 mm. Here reduction of the viscosity to the lowest value gives 1200 N minimal force (at 0.2 m/s velocity and 0.28 Pa·s viscosity), what is more than 6 times larger than necessary (200 N).

So it can be seen, that the necessary range of force can not be achieved by a single channel in the diaphragm when the fluid viscosity and the velocities of the flow are within the range named above. Therefore additional computations have been performed during which the modified model (with several channels connecting the chambers of hydraulic cylinder) was analyzed. As a result of the analysis performed on models having different numbers of different diameter channels, the decision fulfilling the requirements stated at the beginning of the research has been found. It was obtained, that 25 channels of diameter of 3.6 mm ensure the 200–10000 N hydrodynamic force acting the working surface of diaphragm of hydraulic cylinder with the MRF which viscosity is changed correspondingly from 0.28 to 70 Pa·s (Fig. 4, b).

4. Conclusions

The simplified computational finite element model of the rotational hydraulic cylinder loading unit of the academic rowing simulator was built and the computations performed having the aim to evaluate the possibility to realize MRF technology in the hydraulic loading unit of the academic rowing simulator.

It was defined that the necessary range of force (200-10000 N on diaphragm of hydraulic cylinder or 20-1000 N on the oar handle) generated by loading unit can not be achieved by a single channel in the diaphragm separating chambers of the cylinder when the MRF viscosity is within the range of 0.28 to 70 Pa s, because when the diameter of the channel is reduced to ensure maximal force with maximal viscosity of the fluid, the minimum force can not be obtained, and, inversely, when the channel diameter is increased to obtain minimal necessary force with minimal viscosity, the maximal force (at maximal viscosity) is too small.

An additional computations performed on the variety of modified models having different number of different diameter channels led to the conclusion, that 25 channels of diameter 3.6 mm ensure necessary range of

hydrodynamic force acting the working surface of diaphragm of hydraulic cylinder with the MRF which viscosity can be changed correspondingly from 0.28 to 70 Pa·s, as for magnetorheological fluid MRF-140CG.

The further computational analysis of such system is prefigured where the more sophisticated description of the MRF (non-Newtonian) should be used and the law of change of fluid viscosity ensuring necessary law of force on oar handle should be found.

References

1. **Zhurauski, M., Dragašius, E., Korobko, E., Novikova, Z.** Mechanical properties of smart fluids under combined electrical and magnetic fields -Mechanika. -Kaunas: Technologija, 2008, Nr.6(74), p.21-24.
2. **Deheri, G.M., Nihilkumar, D. Abhangi.** Magnetic fluid based squeeze film between curved rough circular plates. -Mechanika. -Kaunas: Technologija. 2008, Nr.4(72), p.34-40.
3. Lord Corporation. Magnetorheological Fluid Applications. Available from <http://www.lord.com/Home/MagnetoRheologicalMRFluid/Applications/tabid/3327/Default.aspx>.
4. Materials of IEEE Systems and Information Engineering Design Symposium (SIEDS'07). April 27, 2007, University of Virginia, Charlottesville, USA. Available from http://www.sys.virginia.edu/sieds07/papers/SIEDS07_0042_FI.pdf.
5. **Kelson, N.A., Doocey, J.M., Rogers, A.A., Brown, R.J.** Initial CFD investigation of an MR fluid in a bicycle ergometer. -In: The 13th Biennial Computational Techniques and Applications Conference, 2-5 July 2006, James Cook University, Townsville, Queensland.
6. **Zatsiorsky, V.M.** Science and Practice of Strength Training. Human Kinetics, 1995, p. 243, ISBN 0-87322-474-4.
7. **Pulman, C.** The Physics of Rowing. Gonville & Caius College, University of Cambridge. Available from: <http://www.atm.ox.ac.uk/rowing/physics/rowing.pdf>.
8. **Bartlett, R.** Sport biomechanics: preventing injury and improving performance. -Routledge. -New York, 1999, p.11-21.
9. **Baudouin, A. and Hawkins, D.** A biomechanical review of factors affecting rowing performance. -Br. J. Sport Med., 2002, 36(6), p.396-402.
10. **Kleshnev, V.** Boat acceleration, temporal structure of the stroke cycle, and effectiveness in rowing. -Journal of Sports Engineering and Technology, volume 224, Number 1 / 2010. ISSN 1754-3371, p.63-74.
11. **Marinus Van Holst.** On Rowing. Revision 2009. Available from <http://home.hccnet.nl/m.holst/RoeiWeb.html>.
12. Indoor rowing pool. Available from: <http://www.northeastern.edu/leadershipcampaign/donors/barletta.html>.
13. Bohler Gymnasium Rowing Tank. Washington State University, Pullman, WA. Available from: <http://www.peterson-architects.com/>.
14. Indoor rowing machine Concept2. Available from: <http://www.concept2.com/us/default.asp>.
15. Indoor rowing machine Rowperfect. Available from: <http://www.rowperfect.com.au/>.

16. Elliott, B., Lyttle, A., Birkett, O. The RowPerfect ergometer: a training aid for on-water single scull rowing. -Sport Biomech., 2002, 1(2), p.123-134.
17. Hislop, S., Cummins, K., Bull, A.M.J., McGregor, A.H. Significant influence of the design of the rowing ergometer on elite athlete kinematics. -Journal of Sports Engineering and Technology, volume 224, Number 1 / 2010. ISSN 1754-3371, p.101-107.
18. Grigas, V., Domeika, A., Legha, A., Satkunskiene, D., Tolocka, R.T. Rowing force and its simulation on training facility. -"Mechatronic Systems and Materials 2008": 4th International Conference, July14 -17, 2008. Bialystok, Poland, p.228-229.
19. Grigas, V., Legha, A., Toločka, R.T. Simulation possibilities of controlled rowing force generated by hydraulic loading unit of training facility -Mechanika. -Kaunas: Technologija, 2009, Nr.2(76), p.65-68.
20. Grigas, V., Legha, A., Sulginas, A., Tolocka, R.T. Rowing force simulation and control system. -Solid State Phenomena, vol.164, 2010, p.161-164.
21. Lord technical data. MRF-140CG Magneto-Rheological Fluid. Available from <http://www.lordfulfillment.com/upload/DS7012.pdf>.
22. Roszkowski, A., Bogdan, M., Skoczynski, W., Marek, B. Testing viscosity of MR fluid in magnetic field. -Measurement Science Review, volume 8, Section 3, No.3, 2008, p.58-60.

V. Grigas, K. Kazlauskienė, A. Šulginas, R. T. Toločka

IRKLAVIMO TRENIRUOKLIO MAGNETOREOLOGINIO APKROVOS ĮRENGINIO SKAITINĖ ANALIZĖ

Reziumė

Straipsnyje pateikiami originalaus irklavimo treniruoklio magnetoreologinio apkrovos įrenginio skaičiavimo srautų analizės (CFD) metodu, naudojant „SolidWorks“ ir „CosmosFloWorks“ programinę įrangą, gauti rezultatai. Tyrimo tikslas – nustatyti, ar tokiu įrenginiu keičiant apkrovos įrenginio sukamojo judesio hidrauliniame cilindre esančio skysčio dinaminę klampą galima sudaryti tokią kintamą pasipriešinimo jėgą, kuri imituotų realią ciklo metu irklą veikiančią apkrovą. Nustatyta, kad reikiamas irklo rankeną veikiančios pasipriešinimo jėgos diapazonas (20-1000 N) negali būti užtikrintas, kai tiriamo 55x60 mm skerspjūvio cilindro diafragmoje yra tik vienas kanalas, pro kurį skystis išteka iš vienos kameros į kitą (naudojant magnetoreologinį skystį MRF-140CG, kurio klampa gali būti nuo 0.28 iki 70 Pa s). Reikiamas pasipriešinimo jėgos diapazonas gali būti gautas, diafragmoje suformuojant dvidešimt penkis 3.6 mm skersmens kanalus.

V. Grigas, K. Kazlauskienė, A. Šulginas, R. T. Toločka

COMPUTATIONAL ANALYSIS OF THE MAGNETORHEOLOGICAL FLUID LOADING UNIT OF ROWING SIMULATOR

Summary

The magnetorheological loading unit of rowing simulator has been investigated by using computational fluid dynamic (CFD) simulation by using SolidWorks and CosmosFloWorks software. The possibility to generate the variable resisting force, corresponding the force acting the oar handle during real rowing, by varying dynamic viscosity of the magnetorheological fluid in the rotational hydraulic cylinder of the loading unit has been examined. It was defined that the necessary range of force generated by loading unit (20-1000 N force on simulator oar handle) can not be achieved by single channel in the 55x60 mm cross-section diaphragm separating chambers of the cylinder under research when the MR fluid viscosity is within the range of 0.28 to 70 Pa s (MRF-140CG). It was found out also that 25 channels of diameter 3.6 mm ensure solution of a problem.

В. Григас, К. Казлаускене, А. Шульгинас, Р.Т. Толочка

ЧИСЛЕННЫЙ АНАЛИЗ МАГНЕТОРЕОЛОГИЧЕСКОГО УЗЛА НАГРУЖЕНИЯ ТРЕНАЖЕРА ГРЕБЛИ

Резюме

В статье приводятся результаты анализа магнитореологического узла гребного тренировочного устройства, проведенного методом вычислительной гидродинамики с использованием программ SolidWorks и CosmosFloWorks. Исследование имело цель проверить возможность генерировать таким узлом переменное усилие, соответствующее усилию на рукоятке весла во время настоящей гребли, путем изменения вязкости жидкости, которой заполнен вращательный гидравлический цилиндр нагрузочного узла. Получено, что необходимый диапазон силы сопротивления на рукоятке (20-1000 Н) не может быть достигнут, когда в диафрагме цилиндра сечением 55x60 мм образован лишь один канал, через который магнитореологическая жидкость MRF-140CG (с вязкостью от 0.28 до 70 Па с) перетекает из одной полости цилиндра в другую. Установлено, что необходимый диапазон силы сопротивления достигается при наличии в диафрагме 25-и каналов диаметром 3.6 мм каждый.

Received August 29, 2010

Accepted December 07, 2010

DOI: 10.5755/j02.mech.15969