

Investigation of anti-intrusion beams in vehicle side doors

E. Černiauskas*, A. Keršys**, V. Lukoševičius***, J. Sapragonas****

*Kaunas University of Technology, Kęstučio 27, 44312 Kaunas, Lithuania, E-mail: egidijus.cerniauskas@stud.ktu.lt

**Kaunas University of Technology, Kęstučio 27, 44312 Kaunas, Lithuania, E-mail: arturas.kersys@ktu.lt

***JSC CADEIS, Kanto 24, 44296 Kaunas, Lithuania, E-mail: vaidas.lukosevicius@cadeis.lt

****Kaunas University of Technology, Kęstučio 27, 44312 Kaunas, Lithuania, E-mail: jonas.sapragonas@ktu.lt

1. Introduction

As the number of vehicles determining accident rate is increasing and higher and higher requirements are raised to their impact estimation and passengers' security, investigations on the above-ground vehicles safety elements and energy absorbing structures are very actual [1]. With the improvement of fast manufacture methods and technologies, application of structures welded and cast of light aluminum profiles and composites has growing popularity in car industry.

Investigations of safety elements absorbing energy were initiated for the cases most often occurring during accidents – crashes and runs down. As a result of this investigation, recommendations for deformation elements of front zones of vehicle, later used for rear body zones, were performed. Gradually investigations of other safety elements were performed.

Side impact case considered in the article – analysis of car accidents testifies, that side impacts make up 30% of all impacts and 35% of them are fatal ones [2-5]. Anti-intrusion beams, designed to save passengers from side impact while strange object intrudes into the cabin space, are mounted within internal door cavity of a vehicle at external plane and fixed to front and rear door supports (Fig. 1). These beams are bent outward slightly – thus impact deformation energy absorbed firstly is directed to door sides which rest on the body struts.

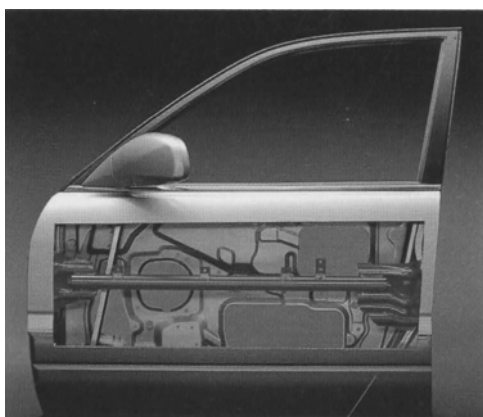

Fig. 1 Car side doors structure

Designing of these elements is considerably complex. Unlike front and rear deformation zones, it is rather complex to arrange in body sides elements, able to deform hardly while absorbing energy. Designing is difficult due to double purpose of these elements – apart from protection against side impact they are used to stiffen the door in order to dissipate impact energy more effectively, in the

case of frontal crash and an impact into the end. Designing is inconvenient as well because there are no completely determined requirements for energy absorbing elements. Investigators in their works analyze side impacts of two types: car to car, and car to pole. In the first case impact of a vehicle moving straight or at some angle or an impact – car impact of the tested vehicle fixed stationary [6] are analysed. In the second case the tested vehicle side impact against stationary fixed pole, imitating tree, lighting pole or other obstacle [7] is analysed.

The first regulated tests of vehicles' impact performed by the company General Motors were oriented more towards behaviour of body structure and strength under short-term impact loading. Though recently in the world there are about ten independent organisations analyzing and evaluating vehicles' safety according to their own rules and standards, no united testing methods exist. Existing standards and regulations substantially differ in strictness of evaluation of tests results.

While improving passive safety means in the case of side impact, side impact test - Federal Motor Vehicles Safety Standard No.214 (FMVSS 214) has been developed by National Highways Traffic Safety Authority (NHTSA) and was extended by including dynamic test with movable obstacle [8] in 1990.

Analyzing behaviour dynamics of completed vehicle and passenger, general requirements to isolated structures are not taken into account [9]. In this work frontal side door anti-intrusion beam behaviour in the sense of safety of the most important car structure combination running into a pole has been investigated.

According to directive FMVSS No.214 in USA quasistatic and dynamic side impact tests have been performed. During quasistatic test the reaction of rigid body intruding into passenger cabin space of the vehicle is determined. The test is performed with a stiff 450 mm cylinder of diameter 300 mm being pushed at constant speed of 0.03 m/s to car doors [10].

According to Euro New Car Assessment Programme (Euro-NCAP) in side impact researches a carriage of 950 kg is deformed (with frontal part of aluminum foam) at 50 km/h strikes against stationary vehicle with dummies in driver and passengers seats.

During the test of side impact against a pole (Fig. 2) a car is fixed on the special carriage and is pushed against stationary fixed pole at the speed of 29 km/h. The car with a dummy in driver's seat is directed towards the pole in such way, that it were in one plane with driver's head. The 254 mm diameter pole during the impact intrudes into the car cabin. Human head injury criteria (HIC) is evaluated.

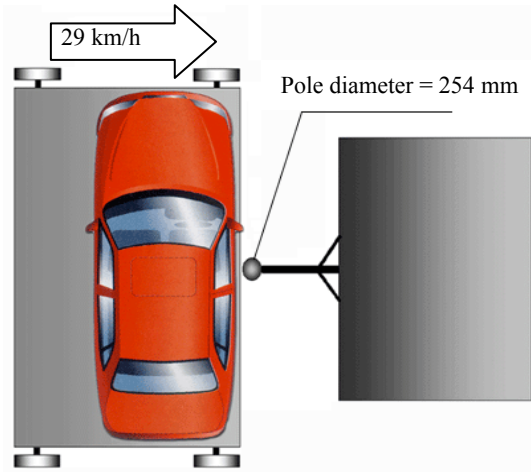

Fig. 2 Test of side impact to the pole according to Euro-NCAP

Fully completed cars of serial production are tested in vehicles side impact research techniques. Anti-intrusion beams are constructive responding doors parts, protecting passengers during an accident with side obstacle, but there are no separate regulations or standards for beams testing. During experimental or computational-experimental side impact researches the interaction of side safety bags, passenger head and central strut and dynamic of the passenger on rear seat cross moving is analysed, but stiffness or strength of side door components is not analysed separately.

2. Experimental and numerical research

Reaction force F deforming car doors by 150 mm without seats and with them mounted is defined by the corresponding expressions. While preparing experimental research, the requirements existing at present and testing methodology was considered. FMVSS directive No.214 foresees a possibility of defining dependence of force-deformations.

Reaction force F deforming car doors by 150 mm without seats and with them mounted is defined by the corresponding expressions:

$$F_{initial} = \frac{\int_0^{150} F d\Delta}{\Delta_{150}} > 5700, \text{ N} \quad (1)$$

$$F_{initial} = \frac{\int_0^{150} F d\Delta}{\Delta_{150}} > 10200, \text{ N} \quad (2)$$

Analogically, when the car is without seats and with them and deformation of the mounted doors is bigger than 300 mm, reaction force makes up:

$$F_{intermediate} = \frac{\int_0^{300} F d\Delta}{\Delta_{300}} > 15870, \text{ N} \quad (3)$$

$$F_{intermediate} = \frac{\int_0^{300} F d\Delta}{\Delta_{300}} > 19840, \text{ N} \quad (4)$$

With the deformation by 450 mm of the car without seats and with them mounted doors, reaction force F_{crush} must be bigger than 31750 and 54420 N, correspondingly.

Experimental investigation of side doors anti-intrusion beams has been performed at Kaunas University of Technology in the laboratory Strength of Materials of K. Vasiliauskas using hydraulic tensile and compression machine of 50 t power (Fig. 3) of the company Amsler.

Experiments were done with real door beams: closed rectangular profile beam of aluminum alloy, circular profile beams with the walls of different thicknesses and with bigger and smaller yield limit and stamped steel beams of different geometric configuration. Their data presented in Fig. 4.

Accuracy of experimental investigation and numerical modelling is determined by approximation of extreme conditions (geometry, loadings and fixing), corresponding real working conditions of side doors beams. Therefore dual fixing systems were chosen for the experiment. Closed cylindrical profiles welded to consoles, which are fixed to lateral bearing structures of the doors, usually are used in vehicles side doors. Because closed aluminum alloy beam is fixed by bolts in a real structure, it was decided to put closed beams on two cylindrical supports. After analogical fixing schemes of anti-intrusion beams have been uniformed, power and stiffness parameters are determined more exactly.

Open profile beams of complicated configuration pressed of sheet steel mostly are welded by spot-welding to door consoles in one or several places. A special frame with reinforcement edges was designed for fixing and placing such beams in the test machine. Open cross-section beams are bolted in the designed frame. It should be admitted, that full uniforming and formalization of supports due to different beams lengths is not avoided. In order to evaluate an effect of supporting surfaces on side door beams stiffness considerably faster and cheaper computational experiments were performed.

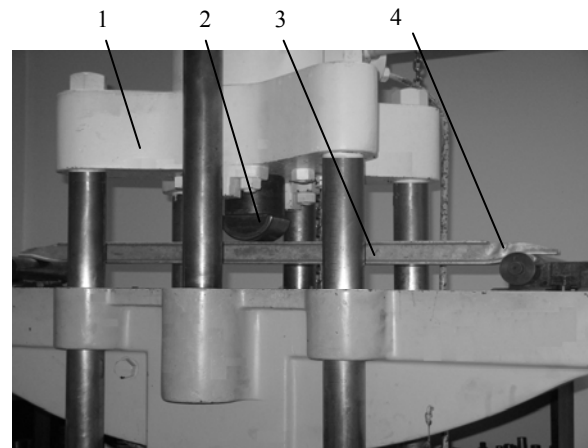
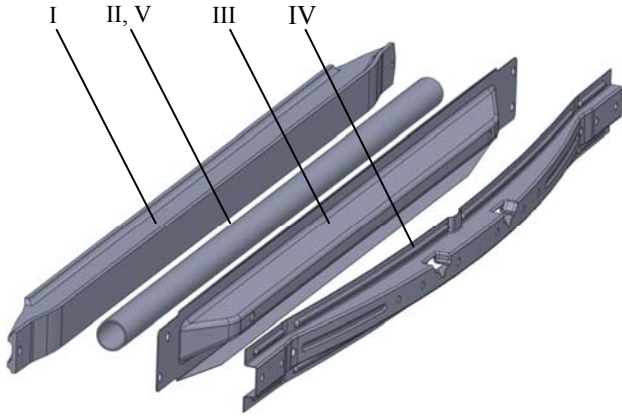

Fig. 3 Anti-intrusion beams testing equipment; 1 - hydraulic tensile/compression testing machine; 2 - punch; 3 - tested anti-intrusion beam; 4 - cylindrical support

For all side door beams experimental research with an uniform punch speed of 0.1 mm/s and stroke of 150 mm has been chosen. A punch of the diameter of 100 mm was pressed at middle point of the beam at the beginning of tests, so eliminating unwanted gaps in the test system and timing beginning of the test.



Profile number and cross-section at the center				
1	2	3	4	5
Distance between supports, mm				
955	760	900	740	820

Fig. 4 CAD models, cross-sections and distance of anti-intrusion beams: I - rectangular aluminum alloy profile; II, V - different length and walls thickness circular steel profiles; III, IV - stamped thin-walled profiles

The experiment was stopped when open profile beams broke at fixing places or closed profile beams lost bending stability. At the same time sudden reaction force decrement till minimum value in displacement diagram was noticed. The obtained results during this experiment confirm preliminary assumptions. Steel beams of pipe type having big yield limit and rectangular beams of aluminum alloy have bending stiffness even several times bigger than open complex configuration pressed steel beams. Prevailing trend, that steel closed pipe beams having spring or high strength welded to side doors consoles right or sideways, used in side door structure system of the most cars, was confirmed.

Though after preliminary analysis of geometry of open profile anti-intrusion beams in the doors is rather difficult to foresee common tendencies prevailing in the structure, that would have some effect on stiffness characteristics, but when idealizing profiles computer models in CATIA system, it was attempted to repeat open profiles geometric and especially reinforcement elements as realistically as possible (Fig. 4).

Experience of calculations by finite elements demonstrates, that local constructive peculiarities ignored in a computational model (rounds off, chamfers and so on), do not have any substantial effect on results accuracy. Finite elements program batch LS-DYNA was used for the calculations.

In this stage, in accordance with common stress distributions and reaction curves, structure rationality un-

der the action of bending loadings and various doors beams fixing conditions was defined. In initial calculations, when there is an attempt to optimize an isolated side door beam according to bending loadings, simplified nonlinear quasistatic calculations may be applied.

Nonlinear tasks usually are solved by explicit or implicit FE methods. The implicit method is steady and does not depend on integration step. But it is complicated to solve short-term nonlinear impact tasks by this method because of solution convergence problems and rather large task size. In this case it is much more rational decision to use explicit method, though due to conditional stability the task solution depends on integration step value, calculated by Courant criteria [7]

$$\Delta t_{max} = a \sqrt{\frac{\rho}{E}} \quad (5)$$

where a is minimum element dimension, ρ is element material density, E is elasticity modulus.

Courant criteria is calculated by the program LS-DYNA automatically so, that minimal integration step condition is always maintained and never violated. But in case of quasistatic tasks, where an impact or punch speed is not big enough, minimal integration step is very small. Because of this reason in order to avoid dynamism effect, dual means are used – punch speed is increased, or density of minimal element is changed.

Whether the task is not dynamical, but static one, is decided according to the ratio of kinetic and internal energy that must be less than 5%. It is provided in recommendations [7] that ≈ 1000 integration steps for one punch step is satisfactory and adequate task fulfilment condition. Therefore, punch speed is increased to 2 mm/ms and such minimal time period is selected, that 1000 integration steps per one punch displacement millimetre are ensured.

While preparing the calculation methodology the known methodologies used for frontal impact, when bearing vehicle structure and main models of longerons absorbing energy and their elements materials are sensitive to deformation velocity were taken into account. Meanwhile in case of side impact, both struts, and door reinforcements are exposed to bending loadings. In this case the influence of deformation velocity may be ignored and structure materials are described by isotropic linear intensifying models.

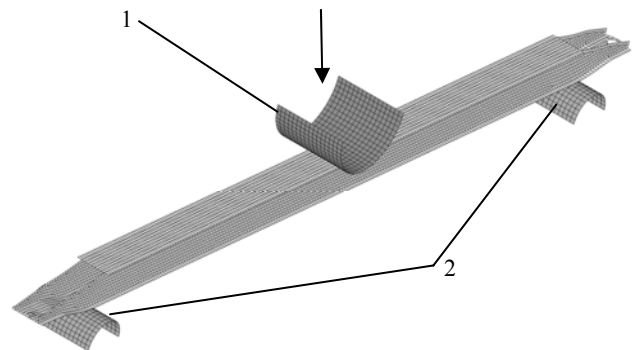

Fig. 5 FE model of anti-intrusion beam calculation: 1 - Ø100 mm rigid punch with intrusion displacement 150 mm; 2 - rigid fixed cylindrical supports

Table
Mechanical properties of side anti-intrusion beam materials

	Profile number and material				
	I	II	III	IV	V
Young's modulus, MPa	69	205	205	205	205
Poisson's ratio	0.33	0.28	0.28	0.29	0.3
Density, kg/m ³	2700	7860	7860	7865	7860
Tangent modulus, MPa	675	5669	1468	763	110
Yield strength, MPa	262	869	430	315	210

Mechanical materials characteristics are presented in Table, computational model is shown in Fig. 5. Using recommendations [9] the uniform LS-DYNA material deformation model of type 3 was selected to all calculation variants. As well, to all FEM calculation variants contact algorithm and Belytschko-Tsay shell elements description in accordance with Mindlin shell theory - elements LS-DYNA of type 2, in the program were chosen as recommended for such tasks. Like in experimental investigation, closed profile beams also are mounted onto absolutely rigid semicylindrical supports, and for open profile beams, using bar elements connection by bolts between profile and absolutely rigid support has been designed.

3. Results and discussions

Strength of vehicle bearing structures, stiffness or energy absorbability is defined by two methods: applying approximate methods and larger assurance factors, and accurate numerical methods and minimized factors. The energetic method is unacceptable in this case, so it is applied wider to various slow cars and structures, the own weight is not actual to them. The second method permits to decrease structures' weight considerably with securing performance safety required, but needs accurate evaluation of all possible structural peculiarities. Simplified calculation schemes were used in initial research stages, with the

evaluation of specific working conditions of vehicle side structure. In simulation by FEM of such complicated structures like vehicle doors, mostly some model simplifications may be realized, with the isolation of specific elements and maintaining extreme conditions, at once accelerating time for the solution without any effect on solution accuracy. In this case some calculation schemes were applied for the same structure, subject to working conditions imitated by the structure. In this stage of investigation the results of experimental and computational research of isolated side door anti-intrusion beams were compared. In this stage of investigation the structure optimality is related to calculation results of power parameters regulated. Bending process diagrams of experimental and computational results of side door closed profile beams are presented in Fig. 6.

Subject to beams stiffness, deformation process may be divided into three typical phases. In the first bending process stage-elastic deformation of a sample is going on, cross-section of the sample grows thinner, the sample deformation is proportional to punch force increment. In the second-plastic deformation stage, with punch force growing, lower force is sufficient to deform the sample. It should be noted, that after deformation of rectangular aluminum alloy beam by 150 mm, the force decrease was not noticed both in experimental, and in computational investigations. Small yield limit of closed circular beams curves characters are quite different, as well. It is very difficult to abstract an elastic deformation zone. With small deformation force, curves tilt gets inconsiderable and larger elastic force increment during beam bending is not noticed.

Though geometric differences among closed profile beams are inconsiderable, nevertheless materials mechanical characteristics change stiffness several times. Besides, it was noticed in initial FEM calculations, that nice mesh has great effect on force characteristics of closed profiles. Therefore while performing numerical experiments on closed profiles it was decided to evaluate the effect of finite elements mesh. In closed high yield limit investigation curves 3 and 4, presented in Fig. 6, we can notice, that curve decline of reaction force obtained by FEM is slightly biased, though the first typical deformation phases intercorrelate quite well.

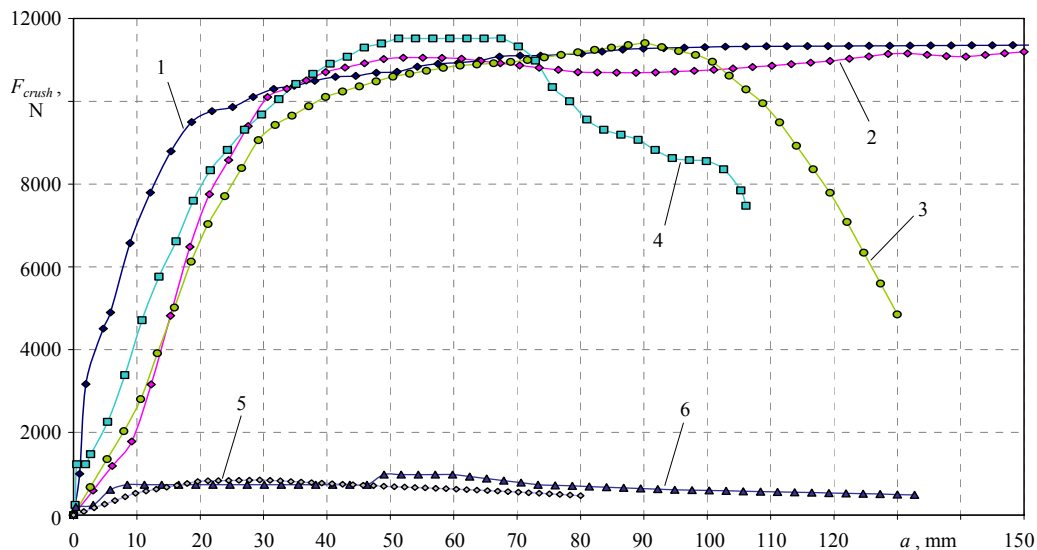

Fig. 6 Relation between reaction force and punch displacement; 1, 3, 5 - experimental curves respectively of I, II, V anti-intrusion beams; 2, 4, 6 - curves obtained by FEM respectively of I, II, V anti-intrusion beams

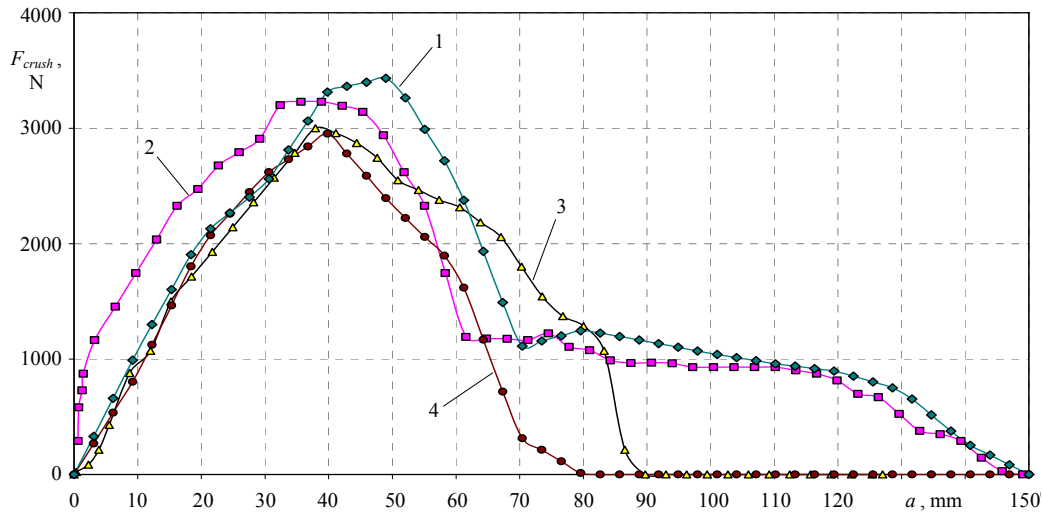

Fig. 7 Relation between reaction force and punch displacement; 1, 3 - experimental curves respectively of III, IV anti-intrusion beams; 2, 4 - curves obtained by FEM respectively of III, IV anti-intrusion beams

With bigger elements used in model the zone of sudden force tilt or bending stability in diagrams moves to the right side, i.e. recedes from defined one experimentally. Therefore in investigations mesh consolidation of 4 levels was applied. A fragment of plastic deformations and mesh consolidation is presented in Fig. 8. We can notice in diagrams of open profile bending experiments and calculations, presented in Fig. 7, that the problem of fixing places emerges – both in experiment, and in computer model, after bending force reaches similar values, plastic strain zone does not separate – the beams suddenly break at bolted connections.

Comparison of the beams of different geometry, but with rather similar mechanical features of materials show that reaction forces both in experimental, and computational diagrams for bending coincide not so bad. The obtained results demonstrate, that detailed computational models reflect experimental investigations adequately.

Emerging problem of beams of different length and fixing was attempted to be solved in the second investigations stage. Distances between beams supports in model were fully uniformed – the selected distance between supports matched the distance used in square profile experiment and investigation. With uniformed distances between beams and supports the results obtained slightly differ from earlier investigations. The problem of degree of freedom of fixing was examined in this stage too – supports in the real side door structure are not absolutely rigid.

A beam fixed in side door can move together with a strut. With the replace of displacement construction used for investigations with absolutely rigid fixing, stiffness of closed profile beams changes inconsiderably. Reaction force of steel beams of II type profile increases slightly, of V type increases up to 1.5 kN, and of open type approximately increases 1.5 times - to 5 kN. Besides, with absolutely rigid fixing of beams considerable strengthening of open profile beams was stated – geometric shape of cross-section has changed at supports and extreme conditions make an isolated structure more rigid considerably. Experimental investigations, as well, confirm the assumption, that the weakest place of stamped anti-intrusion beams is their fixing place. When considering bearing structures of complicated vehicles and calculation schemes it is recommended to investigate stress and deformation state not

only of isolated element and to formulate strength, stiffness and energy absorptivity criteria, but to evaluate behaviour of the whole bearing structure with static lateral loading, as well.

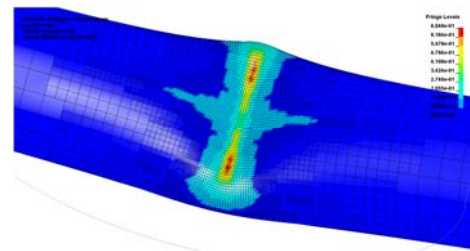

Fig. 8 Plastic strain distribution in circular mild steel anti-intrusion beam

4. Conclusions

1. Standards and regulations used in practise and describing vehicle side impact against an obstacle analyse behaviour of the completed vehicle and passenger dynamics, but common requirements to constructions of an isolated structure are not analyzed.

2. After experimental and numerical investigations, the conclusion should be done, that stiffness of anti-intrusion beams used in various vehicles models differs several times. This makes us to think, that without common requirements to beam strength, usage of sufficiently rigid closed profile beams of different materials and cross-sections might be unreasonable, and open profile beams possibly do not meet minimal stiffness requirements.

3. The designed computational models of side door anti-intrusion beams, allowing to evaluate preliminarily structure stiffness during vehicle impact against side obstacle, reflect experimental investigations of isolated beams rather well. In order to analyze more precisely side vehicle impact against an obstacle and the behaviour of common structure, using developed FE models it is recommended to perform dynamic investigations and analyze force-power characteristics of non-isolated beams.

4. Experiments and FEM calculation results of open profile pressed side door beams confirm, that modeling of fixing places and constructive solution is more ac-

tual than cross-section or material mechanical characteristics of the beams.

5. FE models of side doors anti-intrusion beams demonstrate, that the achieved results depend greatly on material mechanical characteristics, therefore it is advisable to perform corrected mechanical testings of materials used to produce the beams.

References

1. Evaluation of FMVSS 214 - Side Impact Protection: Dynamic Performance Requirement. NHTSA Technical Report, U.S. Department of Transportation, National Highway Traffic Safety Administration, 1999.-238p.
2. **Teng, T.L., Wu, C.H., Wang, S.W.** The injury analysis of occupant in side impact collisions. -Journal of Science and Engineering Technology, 2006, vol.3, No.1, p.33-41.
3. **Rukiža, E., Eidukynas, V., Dulevičius, J.** The influence of seat pad stiffness and damping on the intervertebral forces in the junction of thoracic and lumbar spinal curves. -Mechanika. -Kaunas: Technologija, 2008, Nr.6(74), p.52-55.
4. **Prentkovskis, O., Beliatynskij, A., Prentkovskienė, R., Djakov, I., Dabulevičienė, L.** A study of the deflections of metal road guardrail elements. -Transport. -Vilnius: Technika, 2009, Nr.3, p.225-233.
5. **Rukiža, E., Eidukynas, V.** Investigation of drivers poses influence to the intervertebral forces in the junction of thoracic and lumbar spinal curves. -Mechanika. -Kaunas: Technologija, 2009, Nr.2(76), p.61-64.
6. **Weimer, K.** LS-DYNA User's Guide Cad-Fem GmbH, PwS, 2001.-200p.
7. **Maker, B.N, Zhu, X.** Input parameters for metal forming simulation using LS-DYNA. Livermore Software Technology Corporation, 2000, 10 p.
8. **Prentkovskis, O., Sokolovskij, E., Bartulis, V.** Investigating traffic accidents: a collision of two motor vehicles. -Transport. -Vilnius: Technika, 2010, Nr.2, p.105-115.
9. **Lau, I.V., Capp, J.P., Obermeyer, J.A.** A Comparison of Frontal and Side Impact: Crash Dynamics, Countermeasures and Subsystem Tests. -35th Stapp Car Crash Conference, San Diego, California, p.251, November 18-20 1991. 1991, p.1899-1914.
10. **Teng, T.L., Chang, K.C., Nguyen, T.H.** Crashworthiness evaluation of side-door beam of vehicle. -Technische Mechanik, 2008, Band 28, Heft 3-4, p.268-278.

E. Černiauskas, A. Keršys, V. Lukoševičius, J. Sapragnas
TRANSPORTO PRIEMONIŲ ŠONINIŲ DURŲ
APSAUGINIŲ SIJŲ TYRIMAS

Reziumė

Įvykus šoniniam susidūrimui, priešingai nei priekiniam, nebūna išskirtinių deformacinių zonų. Nors transporto priemonių saugumą apibūdina įvairūs testai ir regla-

mentai, tačiau nė viename iš jų nėra nustatytos šoninių durelių apsauginių sijų stiprumo charakteristikos. Atlikus eksperimentinius skirtingų gamintojų šoninių durelių apsauginių sijų bandymus pastebėta, jog sijų atlaikomos lenkimo apkrovos labai skiriasi, kas leidžia daryti prielaidą, kad montuojama sija ne visuomet atlieka savo funkciją arba mechaninės charakteristikos parenkamos neracionaliai. Sukurti šoninių durelių apsauginių sijų skaitiniai modeliai, leidžiantys preliminariai vertinti konstrukcijos standumą transporto priemonei susidūriant su šonine kliūtimi.

E. Černiauskas, A. Keršys, V. Lukoševičius, J. Sapragnas
INVESTIGATION OF ANTI-INTRUSION BEAMS IN
VEHICLE SIDE DOORS

Summary

In the case of side impact, in contrast to frontal one, there are no distinguished deformation zones. Nevertheless vehicles' safety is characterized by various tests and regulations, but none of them defines strength characteristics of side doors anti-intrusion beams. After experimental testing of side doors anti-intrusion beams produced by different manufacturers it was stated, that the beams support very different bending loadings, what allows to do an assumption, that a beam being mounted not always fulfils its function or mechanical features are chosen unreasonably. Computational models of side doors anti-intrusion beams, allowing preliminarily evaluation of structure stiffness during vehicle impact against side obstacle, were developed.

E. Черняускас, А. Кершис, В. Лукошявичюс, И. Сапрагнас
ИССЛЕДОВАНИЕ ЗАЩИТНЫХ БАЛОК БОКОВЫХ
ДВЕРЕЙ ТРАНСПОРТНЫХ СРЕДСТВ

Резюме

В случае бокового удара, в отличие от фронтального, нет выделяющихся деформационных зон. Безопасность транспортных средств характеризуется различными тестами и регламентами, но ни в одном из них не установлены прочностные характеристики защитных балок боковых дверей. Экспериментальные испытания защитных балок боковых дверей различных производителей показали, что балки выдерживают очень различные нагрузки изгиба, и это позволяет сделать предположение, что установленная балка не всегда выполняет свою функцию или механические характеристики подбираются нерационально. Созданы числовые модели защитных балок, позволяющие предварительно оценивать жесткость конструкции при столкновении транспортного средства с боковым препятствием.

Received July 24, 2010

Accepted December 07, 2010

DOI: 10.5755/j02.mech.15970