

# Modeling, experimental research and critical parameter analysis of glider's dynamic characteristics

A. Rugaitis\*, K. Juočas\*\*, V. Volkovas\*\*\*, V. Deksnys\*\*\*\*

\*Kaunas University of Technology, Studentų str. 50, 51368 Kaunas, Lithuania, E-mail: aurimas.rugaitis@stud.ktu.lt

\*\*Sportinė aviacija ir ko, Pociūnai 59327, Prienai, Lithuania, E-mail: klemas@lak.lt

\*\*\*Kaunas University of Technology, Kęstučio str. 27, 44312 Kaunas, Lithuania, E-mail: vitalijus.volkovas@ktu.lt

\*\*\*\*Kaunas University of Technology, Studentų str. 50, 51368 Kaunas, Lithuania, E-mail: vytautas.deksnys@ktu.lt

## 1. Introduction

Modern gliders are made of composite materials (carbon, glass fiber). In order to enhance their aerodynamic quality (this parameter defines the distance a glider flies as the flight altitude decreases by a kilometer) and to increase critical flight speed, it is necessary to optimize structure of the glider, analyzing conditions of occurring flutter phenomenon. The flutter phenomenon (which means vibration occurring and progressing in certain conditions of glider's structural elements such as wings, fuselage, surfaces of tail or controls) is characterized by critical speed, which depends on multiple parameters: ballast weight, flight altitude, temperature, weight, rigidity and geometry of the structure components. In order to avoid the flutter phenomenon the glider's maximum flight speed and altitude are limited [1, 2], thus it is necessary to know dynamic properties of various structural elements and possible specifications of vibration damping. Finite Element Method (FEM) based modeling of the glider's structure allows defining theoretical dynamic characteristics. Unfortunately, the values applied during modeling not always can be accurately estimated, which in turns requires experimental research and improvements to the models. This is why a lot of attention is given to glider ground and flight tests [3-6]. During the tests structure dynamic characteristics and critical parameters of the glider are identified. This constitutes primary information of a produced glider used for possible forecast of flutter without reaching the critical speed [1, 4].

For the work [7] an original automated system for dynamical tests has been provided designated for ground and flight tests in order to define dynamic characteristics and parameters characterizing the flutter phenomenon. Certain elements of the system were used for analysis of LAK-20T glider wing modes [8]. This study presents the results of FEM-based modeling of glider dynamical characteristics, which are compared to the results of ground tests of a manufactured glider, and structural elements apt to flutter are analyzed. In this way all methodology of measurement and analysis of aircraft dynamical characteristics is practically applied to LAK-17B glider allowing to find imperfections in the structure and receive information about occurrence of the flutter phenomenon in separate structural elements of the glider.

## 2. Aspects of glider modeling and testing

Designing a glider to a specified structural solution foresees the elaboration of a model of finite elements

and its analysis. Results of numerical dynamical tests – natural vibration frequencies and their forms are used for the evaluation of critical flutter speed. Upon building of a glider's prototype, its structural elements are weighed in, their rigidity is defined and ground dynamical tests (GDT) are conducted. According to the results of performed tests the model structure is adjusted and critical flutter speed analysis is conducted [1].

For performance of the GDT the devices to excite and measure vibration are necessary. For excitement of vibrations a two-channel programmed harmonic signal source is necessary, with frequency oscillation range of (0.5 – 70) Hz. In this frequency range characteristic modes are observed. Phase difference between the channel signals should also be alternating, so that it would be possible to create different modes of vibration of the elements.

These requirements are met by a specially developed Glider Dynamic Testing System (GDTS) [7], which was used for performance of the glider tests. Vibration parameters were measured with triaxial vibration parameter measurement transducers in order to monitor vibration modes in three planes in multiple points of the structure. For objective monitoring of the glider dynamical test results 30 measurement points were used.

During ground dynamical tests resonant frequencies  $\omega_{rez}^k$  and logarithmic decrements  $\lambda_k$  are measured for each vibration mode [8]. With respect to the glider structure this is especially important for elastic wings, ailerons and vertical stabilizer, since depending on the values of these parameters various phenomena including flutter are possible. Optimizing damping coefficient and resonant frequencies of elements' vibrations it is possible to avoid interaction of close resonant frequency modes and abrupt damping shift as well as occurrence of flutter of the glider's elements [3, 6]. That allows to verify and to estimate product quality in its life cycle phase – product development stage [9].

## 3. FEM modeling results

Finite Element Method is used for modeling of dynamical characteristics of gliders as well as of other aircraft and various structures. For practical applications of the method various software programs are developed including specialized EMRC NISA Family of Programs – Version 12.0 [10.] For modeling of the glider's structure the following finite element types were used: 3-D LAMINATED COMPOSITE GENERAL SHELL ELEMENT (NKTP = 32) and 3-D LAMINATED SANDWICH GENERAL SHELL ELEMENT (NKTP =

33). Upon developing of the glider’s finite element model, resonance modes and their allocation in the wing were obtained. Theoretical by modeled natural frequencies of the glider wing are presented in Table 1.

The corresponding two modes are shown in Fig.1 - 4. Fig. 5 illustrates the fuselage twisting mode.

Table 1

Glider wing natural frequencies, Hz

Mode	Symmetric	Asymmetric
I	2.26	1.68
II	733	6.63
III	17.06	15.87

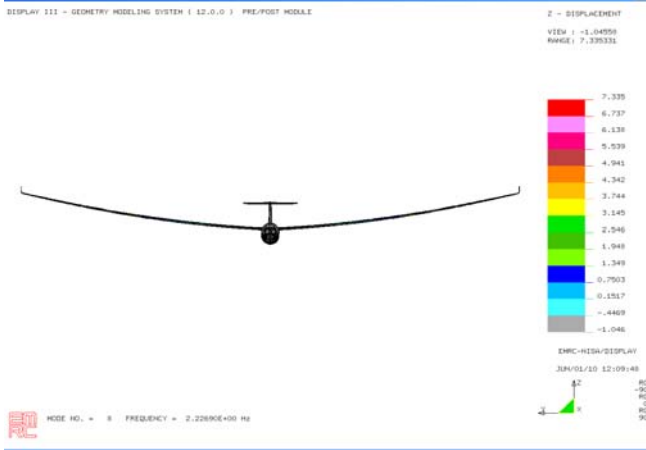

Fig. 1 I symmetric wing mode



Fig. 2 II symmetric wing mode

III

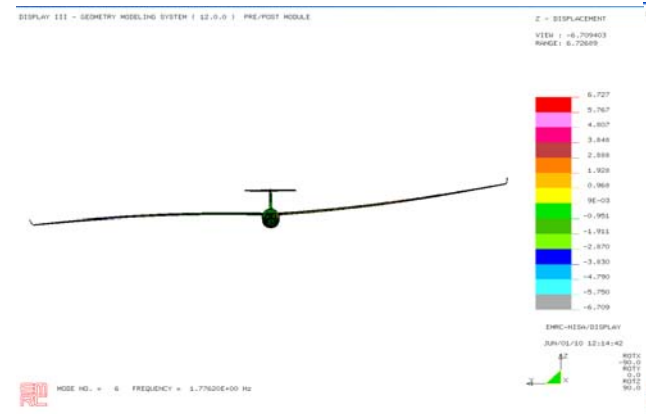

Fig. 3 I asymmetric wing mode

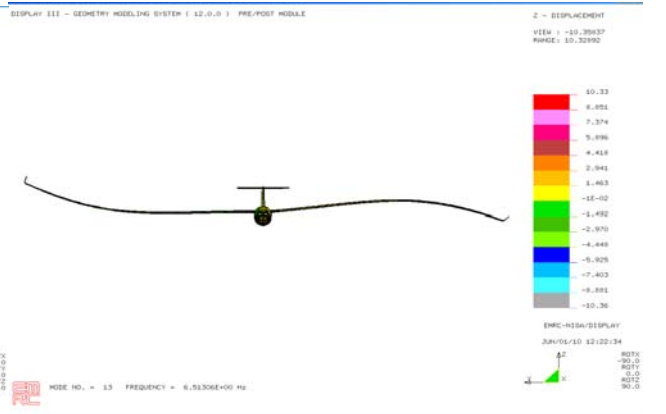

Fig. 4 II asymmetric wing mode

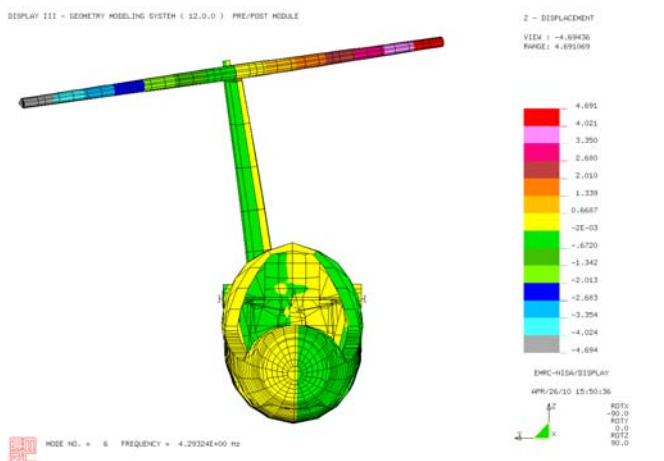

Fig. 5 Fuselage twisting mode

The second Table presents certain twisting and bending modes of the glider fuselage.

The created theoretical model of the glider allows with the help of a numerical experiment to model different situations and to receive dynamical characteristics corresponding to them. In case of flutter the prevailing charac-

Table 2

Fuselage mode natural frequencies, Hz.

Mode	Horizontal plane	Vertical plane
Bending	11.13	15.61
Twisting	4.29	

teristics are element resonant frequencies and damping. To estimate and verify adequacy of the theoretical modeling we have applied the second stage of the methodology, i.e. ground dynamical tests. To that purpose we conduct research in a specific LAK-17B glider.

#### 4. Results of ground dynamic tests of LAK-17B glider

LAK-17B glider ground dynamic tests were conducted with the developed GDTS, measurements were taken using wireless acceleration sensors located according to the layout shown in Fig. 6.

Having performed spectral analysis of the received data the following wing resonant modes were defined:

- I wing symmetric mode –  $F = 1.53$  Hz;
- II wing symmetric mode –  $F = 6.06$  Hz;
- III wing symmetric mode –  $F = 14.6$  Hz;

I wing asymmetric mode –  $F = 0.93$  Hz;  
 II wing asymmetric mode –  $F = 4.14$  Hz;  
 III wing asymmetric mode –  $F = 14.4$  Hz;  
 Fuselage twisting mode –  $F = 4.12$  Hz;  
 Fuselage horizontal plane bending I mode –  $F = 11.05$  Hz;

Fuselage vertical plane bending I mode –  $F = 15.51$  Hz.

An example of the wing vibration spectrum is presented in Fig. 7.

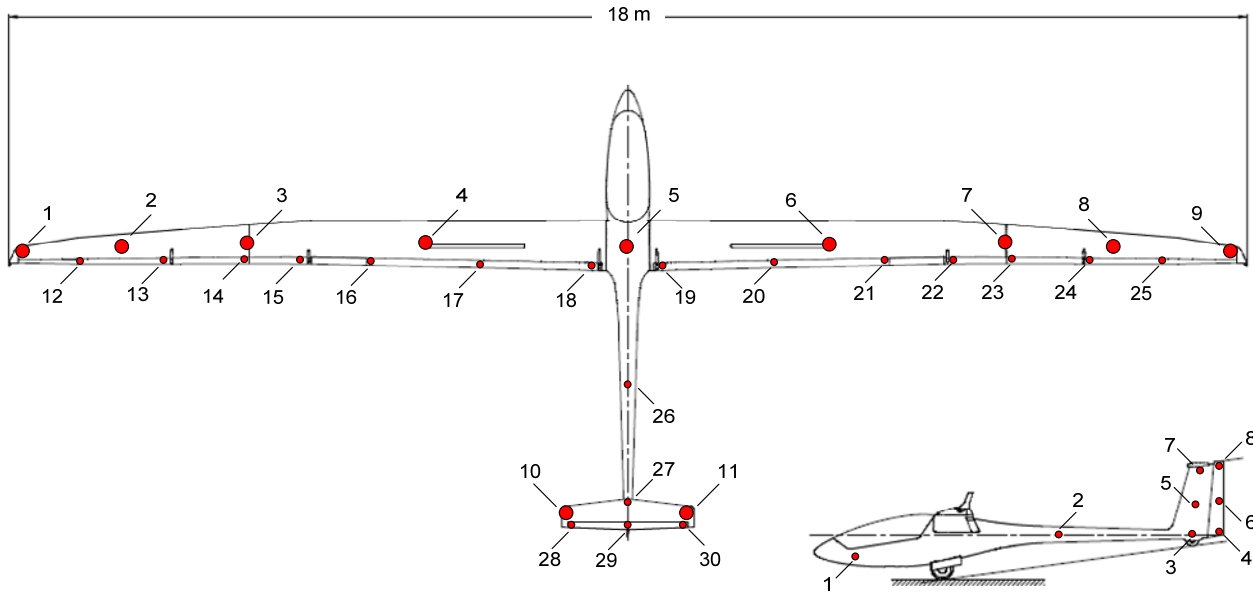

Fig. 6 Transducer layout diagram

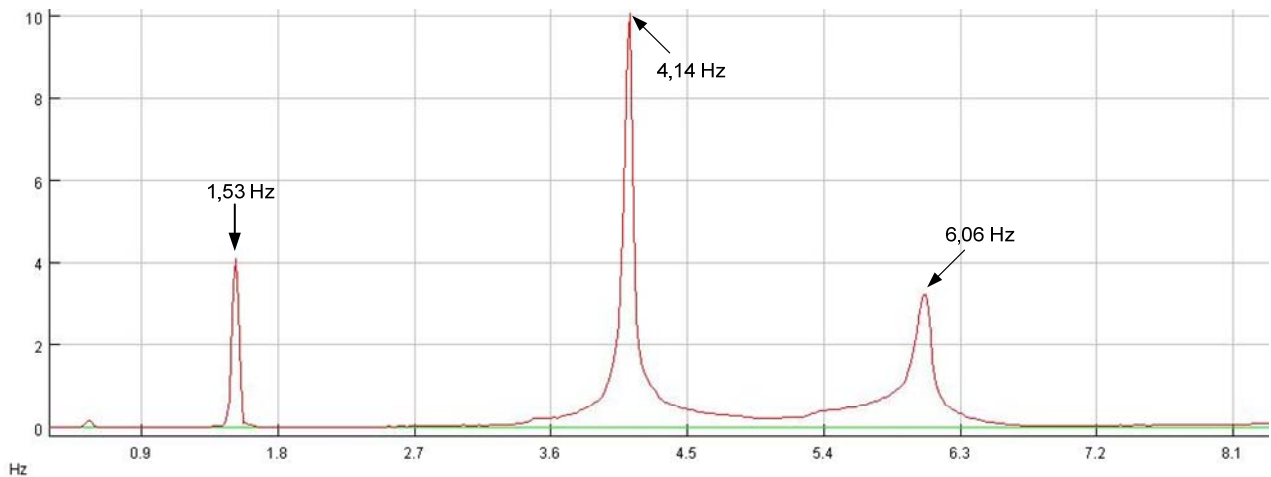

Fig. 7 Vibration spectrum of the glider's wing

Having compared resonant mode frequencies of the theoretical estimations and obtained experimental results the discrepancy reaches up to 15%.

During the testing it was received that for II wing asymmetric mode –  $F = 4.14$  Hz and the fuselage twisting mode –  $F = 4.12$  Hz the difference was only 0.02 Hz. Such close resonant mode frequencies can evoke overlap of the modes and abrupt damping decrement shifts of one of the modes.

### 5. Experimental evaluation of decrements

Information obtained during the testing allowed defining the wing mode decrements. For estimation of the decrements vibration processes, which were measured at simultaneous stoppage of vibration excitement at a resonant frequency were used (Fig. 8). The decrements were calculated according to the formula

$$\lambda = \frac{1}{n} \ln \frac{A_1}{A_n}$$

where  $n$  is the number of oscillations,  $A_1$  is amplitude of the first oscillation,  $A_n$  is amplitude of the  $n$ -th oscillation.

Obtained decrements of all desired modes are presented in Table 3, where damping decrements of another glider - LAK-17A are presented for comparison too.

Wing profiles for comparison are presented in Fig. 9. Wing area of LAK-17B compared to that of LAK-17A is increased from 9.8 to 10.32 m<sup>2</sup> and mass is increased from 55-56 to 60-62 kg. Rods used for ailerons are altered just as well. The frequency of the second asymmetrical mode derived from the theoretical EF model is 6.63 Hz, while the frequency obtained during the test is 4.14 Hz. Since other theoretical frequencies correspond to the experimental frequency outcomes, this gives rise to an

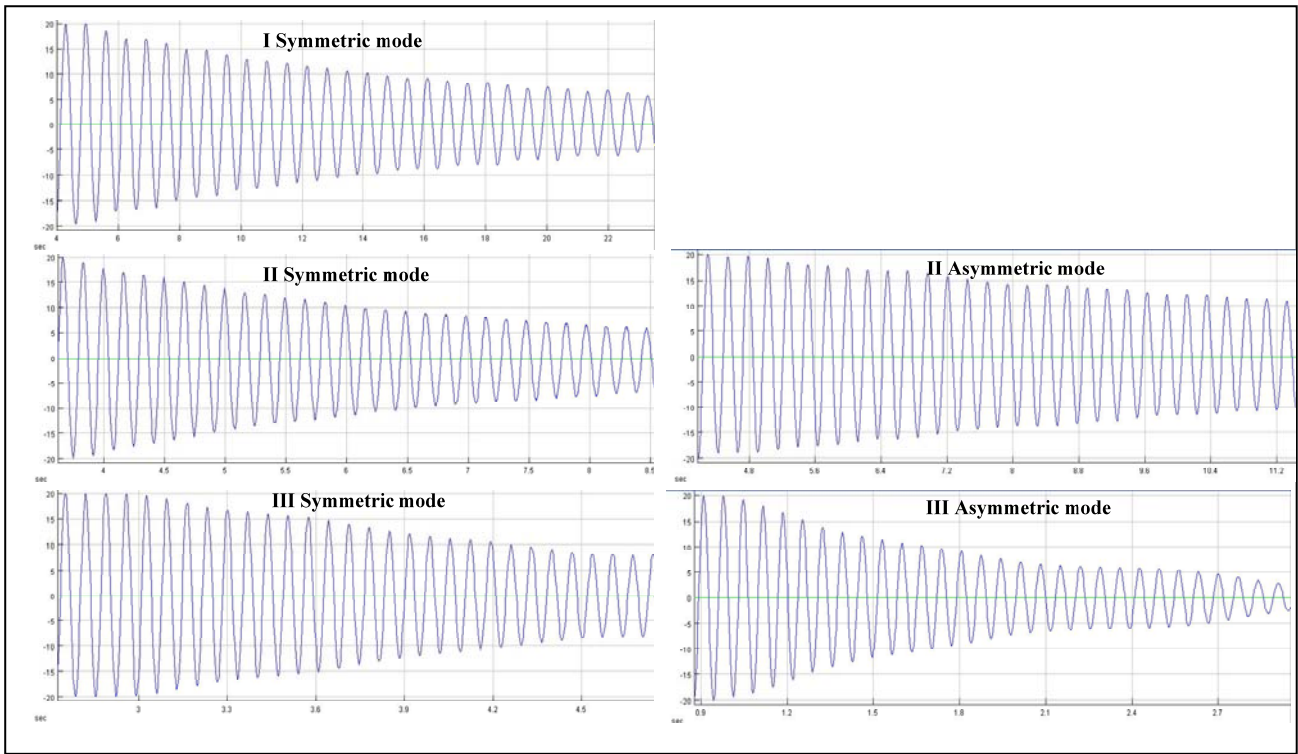

Fig. 8 Wing bending mode damping curves

Table 3

Glider wing decrement values

Mode	LAK 17B		LAK 17A	
	Symmetric	Asymmetric	Symmetric	Asymmetric
I	0.049	0.07	-	0.07
II	0.049	0.025	0.06	0.08
III	0.045	0.06	0.08	0.09

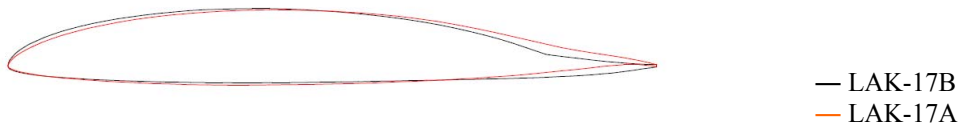

Fig. 9 LAK-17 type wings profiles

assumption that the wing profile of glider LAK-17B may contain structural imbalances, which were also expressed in the extremely low decrement of the second asymmetrical mode ( $\lambda = 0.025$ ).

## 6. Conclusions

Having performed the FEM modeling and ground dynamic tests parameters of LAK-17B glider were specified (discrepancy with the theoretical estimations made up to 15%). During the tests a combination of the second wing bending asymmetric mode and the fuselage twisting mode was identified, which was not found and estimated at the modeling stage. During over ground experiments, own gliders parts and their critical combination for flutter bend and twist modes are estimated, i.e.: the difference of frequencies of the II wing asymmetric mode and the fuselage twisting mode was only 0.02 Hz. and extremely low dec-

rement of the second asymmetrical mode. The results can be revised using two methods: by modeling turbulent flows [11] or during repeated experiments (in aerodynamic tube or during test flights). With a help of the created equipment during the test flights of the glider LAK-17B, the parameters of dynamic characteristics will be revised and published later.

The mode combination found at the early testing stage allows easier adjustment of the structure. The received results will allow a more precise forecast of critical parameters till critical speed is reached.

The offered methodology of identification and analysis of dynamical characteristics as well as corresponding hardware and software products ensure thorough design, tests and optimization of gliders forecasting flutter of elements and identifying critical glider parameters, as well as securing safety of the aircraft.

## References

1. **Hollmann Martin.** Modern Aerodynamic Flutter Analysis. -Monterey, CA, Aircraft Designs, Inc., 1991. -160p.
2. **Andrew Dimaragonas.** Vibration for Engineers. - Prentice-Hall International Inc., 1996.-825p.
3. **Michael, W. Kehoe, Lawrence, C. Freudinger.** Aircraft Ground Vibration Testing at the NASA Dryden Flight. 1994.-23p.
4. **Rick, C. Lind.** A Presentation on Robust Flutter Margin Analysis and a Flutterometer, 1997.-67p.
5. **Starr Potter, Rick Lind.** Developing Uncertainty Models for Robust Flutter Analysis Using Ground Vibration Test Data, 2001.-21p.
6. Multidisciplinary Optimization and Sensitivity Analysis of Flutter of an Aircraft Wing with Underwing Store in Transonic Regime, 2003.-92p.
7. **Deksny, V., Rugaitis, A., Juočas, K.** System for glider flutter investigation. -Matavimai, 2006, Nr.2(38), p.26-29.
8. **Rugaitis, A., Deksny, V., Volkovas, V.** The system of glider dynamic measurements and critical parameters analysis. -Journal of Vibroengineering, 2009, Nr 11(2), p.233-239.
9. **Čikotienė D., Bargelis A.** Research of quality impact to the product design properties and characteristics. -Mechanika. -Kaunas: Technologija, 2009, Nr.5(79), p.63-67.
10. EMRC NISA/DISPLAY User's Manuals. 2003. 530 p.
11. **Benhamza M.E., Belaid F.** Computation of turbulent channel flow with variable spacing riblets. -Mechanika. -Kaunas: Technologija, 2009, Nr.5(79), p.36-41.

A. Rugaitis, K. Juočas, V. Volkovas,  
V. Deksny

SKLANDYTUVŲ DINAMINIŲ CHARAKTERISTIKŲ  
MODELIAVIMAS, EKSPERIMENTINIAI TYRIMAI IR  
KRITINIŲ PARAMETRŲ ANALIZĖ

## Reziumė

Darbe nagrinėjami sklandytuvų dinaminių charakteristikų modeliavimo ir antžeminių bandymų rezultatai. Pateikta sklandytuvo konstrukcijos savųjų dažnių ir flaterio reiškinį apibūdinančių parametrų nustatymo metodika, analizuojamos priemonės, sukurtos sklandytuvų antžeminiams dažniniams bandymams atlikti. Sklandytuvo LAK-17B konstrukcijos elementų rezonansinių dažnių modeliavimo rezultatai lyginami su eksperimentiniais antžeminių dinaminių bandymų rezultatais. Parodytas metodikos taikymo efektyvumas – nustatyta, kurie sklandytuvo konstrukcijos elementai gali būti veikiami flaterio reiškinio, bei tų elementų virpesių dekrementai.

A. Rugaitis, K. Juočas, V. Volkovas,  
V. Deksny

MODELING, EXPERIMENTAL RESEARCH AND  
CRITICAL PARAMETER ANALYSIS OF GLIDER'S  
DYNAMIC CHARACTERISTICS

## Summary

The work studies results of glider dynamical characteristics modeling and ground tests. It presents a methodology of defining natural frequencies of glider structure and parameters characterizing flutter phenomenon, analysis of developed means designated for performance of glider ground frequency tests. The paper presents results of modeling of resonant frequencies of LAK-17B glider structural elements, which are compared to experimental results of ground dynamical tests. The efficiency of application of the demonstrated methodology allows defining possible flutter phenomena of structural elements of the mentioned glider and their vibration decrements.

A. Ругайтис, К. Иочас, В. Волковас,  
В. Дякснис

МОДЕЛИРОВАНИЕ ДИНАМИЧЕСКИХ  
ХАРАКТЕРИСТИК, ЭКСПЕРИМЕНТАЛЬНЫЕ  
ИССЛЕДОВАНИЯ И АНАЛИЗ КРИТИЧЕСКИХ  
ПАРАМЕТРОВ ПЛАНЕРОВ

## Резюме

В работе исследуются результаты моделирования динамических характеристик и наземных испытаний планеров. Приведена методика проведения наземных частотных испытаний планеров для определения собственных частот и параметров, характеризующих явление флаттера. Приведены результаты моделирования резонансных частот элементов конструкции планера LAK-17B, которые сравниваются с экспериментальными результатами наземных испытаний. Эффективность применения методики демонстрируется определением склонных к флаттеру элементов конструкции данного планера и декременты их колебаний.

Received August 23, 2010  
Accepted December 07, 2010

DOI: 10.5755/j02.mech.15978