

Energy regenerative braking ABS control research on feedback lockup driving-braking integrated system for electric vehicles

Guoye Wang, Hang Xiao, Juanli Zhang, Fang Wang

Vehicle and Traffic Engineering Department, College of Engineering, China Agricultural University, Beijing, China,

E-mail: wgy1615@126.com

crossref <http://dx.doi.org/10.5755/j01.mech.18.3.1871>

1. Introduction

For continuous development, vehicles become the main field of world energy depletion. It is more and more important and urgent to develop the vehicle techniques of economy energy. In various vehicle techniques of economy energy, the regenerative braking technique is interested at all times, and has good application foreground, it already has abundant research results and application [1-5], and it will become the important path of vehicle economy energy. But at the present various regenerative braking techniques still have many problems, such as regenerative braking efficiency is not high, the brake performance can not be guaranteed, and so on [6-8]. The ABS control technique based on regenerative braking system of electric vehicle is not mature till now.

To solve these problems, based on the dynamic system of wheel motor electric vehicle, this paper project the energy regenerative braking feedback lockup braking-driving integrated system for electric vehicles. Set up the system dynamic model based on the Matlab/Simulink, establish the simulation system of dynamic and ABS control of the electric vehicles regenerative braking system. By simulation system, we respectively simulate and analyse the feedback lockup regenerative braking performances with or without ABS control on three conditions of driving straightly on high adhesion condition ground, low adhesion condition ground, and steering driving on a curve path.

2. Feedback lockup braking-driving integrated system

The feedback lockup braking-driving integrated system for electric vehicles is composed of feedback brake transmission component, brake pushing component, brake component, braking energy reusing component, as shown in Fig. 1. The feedback brake transmission component is mainly composed of the driven gear of first class transmission 2, the driving gear of second class transmission 3, the driven gear of second class transmission and pushing screw 4 (two components are combined together), the bearing on the head face of the pushing screw 15. The brake pushing component is composed of the pushing nut and driving gear of third class transmission 9 (the two components are combined together), the bearing on the head face of the pushing pillar 10, pushing pillar 13, the pushing pillar returning back spring 14. The braking energy reusing component is composed of the driven gear of third class transmission 8, the driving gear of fourth class transmission and brake clutch 6 (the two components are combined together), the rotor of wheel motor and driven

gear of fourth class transmission 5 (two components are combined together), the driving clutch 19, the stator of wheel motor 20. The brake component is composed of braking pliers 11, braking blocks 12, braking disc and the driving gear of first class transmission 16 (two components are combined together).

When the vehicle is in braking, the brake clutch 6 is merged, while the driving clutch 19 is detached, the wheel motor works as a generator, the feedback brake transmission component feedback the wheel moving energy to the brake pushing component through transmission components, brake pushing component respectively transmits the moving energy to the braking energy reusing component and the brake component, thus realizes the vehicle braking. Through controlling the generating capacity of the wheel motor, the integrated system can work in two modes: mode of wheel motor braking only, mode of both the wheel motor and the brake braking at the same time; when slight strength of braking needs, make the generating capacity of the wheel motor in the braking energy reusing component reducing, and the lockup force that the wheel motor acts on the driving gear of third class transmission 9 reduces too through transmission components, this makes the pushing nut 9 couldn't overcome the force that the pushing pillar returning back spring 14 acts on the pushing pillar 13, at this moment, the braking blocks 12 do not brake, namely the mode of wheel motor braking only, the braking energy is totally converted into recyclable electric energy through wheel motor; when strong strength of braking needs, make the generating capacity of the wheel motor increasing, and the lockup force that the wheel motor acts on the driving gear of third class transmission 9 increases too, when the pushing force that the pushing nut 9 acts on the pushing pillar 13 increases to bigger than the force that the pushing pillar returning back spring 14 act on the pushing pillar 13, the braking blocks 12 do brake, namely the mode both the wheel motor and the brake braking at the same time, one part of the braking energy is converted into recyclable electric energy through wheel motor, the other part is converted into heat through brake and been consumed.

When the vehicle is in driving, the wheel motor works as a electric motor, and the brake clutch 6 is detached, while the driving clutch 19 is merged, the power of the wheel motor will be directly transferred to the axle 17 through the driving clutch 19, driving the wheel 18 to move forward; at the same time, the brake component does not generate feedback brake.

As compared with EMB (Electromechanical Brake), the feedback lockup braking-driving integrated system generate electric energy, EMB consume electric

energy. As compared with other regenerative braking systems for the electric vehicle, it has more the regenerative braking efficiency especially at lower speed.

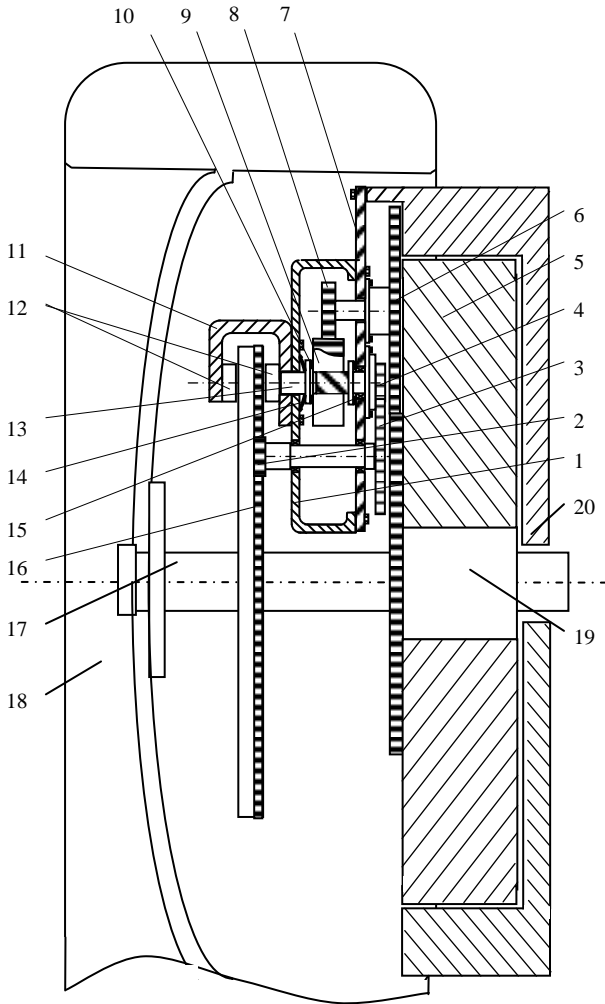

Fig. 1 The feedback lockup braking-driving integrated system for electric vehicles: 1 - shell; 2 - driven gear of first class transmission; 3 - driving gear of second class transmission; 4 - driven gear of second class transmission and pushing screw; 5 - rotor of wheel motor and driven gear of fourth class transmission; 6 - driving gear of fourth class transmission and brake clutch; 7 - sustain board; 8 - driven gear of third class transmission; 9 - pushing nut and driving gear of third class transmission; 10 - the bearing on the head face of the pushing pillar; 11 - braking pliers; 12 - braking blocks; 13 - pushing pillar; 14 - the pushing pillar returning back spring; 15 - the bearing on the head face of the pushing screw; 16 - braking disc and the driving gear of first class transmission; 17 - axle; 18 - wheel; 19 - driving clutch; 20 - stator of wheel motor

3. Dynamics of feedback lockup braking-driving integrated system

The forces between the pushing screw and nut in braking process, as shown in Fig. 2, where F_{N1} , F_{N2} , F_{N3} respectively are the normal forces on the head face of the pushing screw, screw interface, between the pushing nut and the third class gear, N ; f_1 , f_2 , f_3 are the friction coef-

ficient of above-mentioned three friction pairs; α is the screw angel of the pushing screw pair; F_1 is the feedback force that the braking disk acts on the head face of the pushing screw action radius by the feedback brake transmission component, N ; F_{N4} is the lockup force, that is the pressing force which the pushing nut acts on the braking blocks, generated from braking disc and the driving gear of first class transmission 16 drives. The feedback brake transmission component and the generator pushes the pushing nut, feedback acted on the front face of the braking disk by the braking blocks; f_4 is the head face friction coefficient of the pushing nut; F_{f1} , F_{f2} , F_{f3} and F_{f4} respectively are the friction forces on the head face of the pushing screw, screw interface, tooth face of the pushing nut, and the head face of the pushing nut, N .

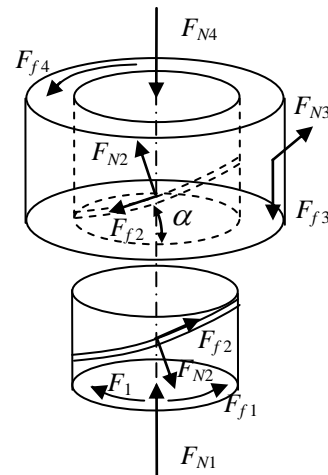

Fig. 2 The forces between the pushing screw and nut in braking process

The dynamic equations of the pushing screw

$$\begin{cases} F_1 R_1 = F_{f1} R_1 + F_{f2} R_2 \cos \alpha + F_{N2} R_2 \sin \alpha \\ F_{N1} + F_{f2} \sin \alpha = F_{N2} \cos \alpha \end{cases} \quad (1)$$

where R_1 , R_2 respectively are the action radius of the friction forces on head face of the pushing screw and the screw middle radius, m; other parameters are same as before.

The dynamic equations of the pushing nut

$$\begin{cases} F_{N4} + F_{f3} + F_{f2} \sin \alpha = F_{N2} \cos \alpha \\ F_{f2} R_2 \cos \alpha + F_{N2} R_2 \sin \alpha = F_{f4} R_4 + F_{N3} R_3 \end{cases} \quad (2)$$

where R_3 , R_4 respectively are the radius of the pushing nut gear and the action radius of the friction forces on head face of the pushing nut, m; other parameters are same as before.

The dynamic equations of the feedback brake transmission component, the lockup brake component and the braking energy reusing component

$$\begin{cases} T_{be} = F_{N3} R_{c3} \\ T_{b1} = \frac{F_1 R_1}{i_1 i_2 \eta_1 \eta_2} \\ T_{b2} = 2 F_{N4} f_b R_b \end{cases} \quad (3)$$

where R_{c3} , R_b respectively are the radius of the generator gear and the action radius of the braking friction forces on the braking disk, m; T_{b1} , T_{b2} , T_{be} respectively are the braking torque that the feedback brake transmission component acts on the braking disk by the braking disk gear, the braking torque that the lockup force acts on the braking disk and the generator braking torque, Nm; f_b is the braking face friction coefficient of the braking disk; i_1 , i_2 respectively are the first class gear and from the driving decelerating gear to the driven decelerating gear; η_1 , η_2 respectively are corresponding transmission efficiency.

Using permanent magnet brushless DC hub motor, its dynamic equations is [9]

$$\begin{cases} I_e \dot{\omega}_e = T_{be} - T_e - T_0 \\ \omega_e = \frac{\omega_w}{i_1 i_2 i_3 i_4} \\ T_e = C_r \Phi I_a \end{cases} \quad (4)$$

where I_e is the rotor and prime mover driven pieces' moment of inertia, kgm^2 ; ω_e is the rotor and prime mover driven pieces' rotational speed, rad/s ; T_e is electromagnetic torque, Nm; T_0 is motor mechanical resistance torque, Nm; C_r is torque constant of DC motor; Φ is magnetic flux per pole, Wb; I_a is motor electric current, A.

Eqs. (1)-(4) fit for modelling of ABS because when F_{N3} is small F_{N4} is also small without direction change for the no-self-locking screw.

The wheel's regenerative braking efficiency

$$\eta_b = \frac{T_e \omega_e}{(T_{b1} + T_{b2}) \omega_w} \quad (5)$$

According to the structure and the dynamics of the feedback lockup braking-driving integrated system (Eqs. (1)-(3)), the screw angle of the pushing screw pair α is main variable parameter, when it becomes larger, the generator braking torque and power will become larger, and the regenerative braking efficiency will become higher too. For electric car, the capacity of the vehicle accumulator and the need of the generated electricity quantity are relatively larger, so we can choose the screw angle α to be larger, and through optimizing the structure, combine the driving electric motor and the braking energy feedback generator to make the structure space, the car weight and the whole car performances more reasonable.

It is known that in the low-strength-brake, the brake friction faces do not work, the vehicle is braked by the braking generator through the feedback brake transmission component, and the regenerative braking efficiency is relatively high. The study shows: in vehicle running, most of the braking conditions are the low-strength-brake, the high-strength-brake conditions are little [10, 11], so the regenerative braking efficiency is relatively high in the whole vehicle running. In the high-strength-brake conditions, the brake friction faces work for braking, the brake strength increases, it can guarantee the vehicle emergent braking safety.

4. Performances analysis of ABS control with the energy regenerative braking

Based on the feedback lockup braking-driving integrated system, we use the fuzzy self-adapted ABS control strategy to realize the energy regenerative braking. To verify the performances of ABS control, we establish the dynamic simulation test system of the feedback lockup braking-driving integrated system based on the Matlab/Simulink. Using the parameters of the Chery A3 car as the system parameters of vehicle, we respectively simulate and analyse the regenerative braking performances with or without ABS control on three conditions of driving straightly on high adhesion condition ground, low adhesion condition ground and steering driving on a curve path.

Use the brake torque of the left-front motor and slip rate as performance indicators of single wheel ABS control, use the braking deceleration of vehicle barycentre, path and side-slip angle as performance indicators of the whole vehicle ABS control. Figs. 3, 5, 7 are the braking performance graphs of left-front wheel, horizontal coordinates are times t , s, vertical coordinates are motor brake torque T_{be} , Nm and wheel slip rate s ; Figs. 4, 6, 8 is the braking performance graph of the whole vehicle, horizontal coordinates are the vehicle barycentre movements on X axis, m, vertical coordinates are the vehicle barycentre movement on Y axis, m, barycentre accelerate, m/s^2 and side-slip angle, degree.

4.1. Vehicle's braking performance driving straightly on high adhesion condition ground

The single wheel ABS control performance driving straightly on high adhesion condition ground is shown in Fig. 3.

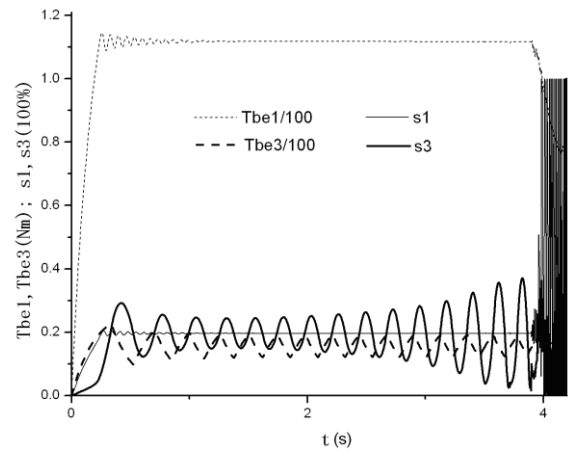

Fig. 3 The single wheel ABS control performance driving straightly on high adhesion condition ground

The initial vehicle velocity is set $v_0 = 120 \text{ km/h}$, the ground adhesion condition is 0.85, T_{be1} , s_1 are the left front wheel's motor braking torque and wheel slip ratio, T_{be3} , s_3 are the left back wheel's motor braking torque and wheel slip ratio. As shown in the picture, the left front wheel's motor braking torque ranges in a small area around 110 Nm, its slip rate ranges in a small area around 0.2, so the control performance is good; the left back motor brak-

ing torque ranges between 10 and 20 Nm, its slip rate ranges between 0.1 and 0.3, for a shift in vehicle's mass when braking, the left front wheel's braking force is far large than the back wheel, the front wheel ABS control performance is also better than the back wheel, these performances are the same as normal vehicles.

The whole vehicle ABS control performance when the vehicle driven straightly on high adhesion condition ground is shown in Fig. 4, the average braking deceleration of the center of vehicle's mass is about 8.2 m/s^2 , the mass center's side displacement and lateral angle are nearly zero, the whole vehicle ABS control has better braking efficiency and stability.

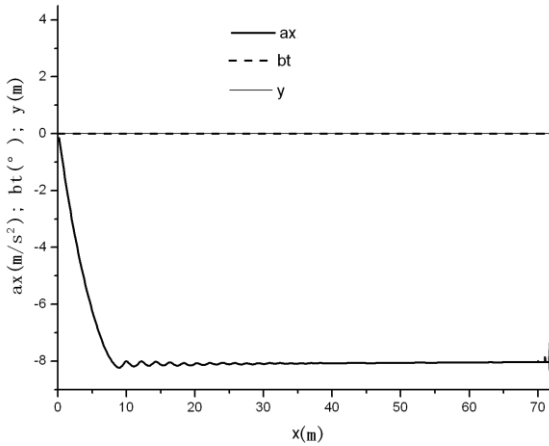

Fig. 4 The whole vehicle ABS control performance driving straightly on high adhesion condition ground

4.2. Vehicle's braking performance driving straightly on low adhesion condition ground

The single wheel ABS control performance driving straightly on low adhesion condition ground is shown in Fig. 5.

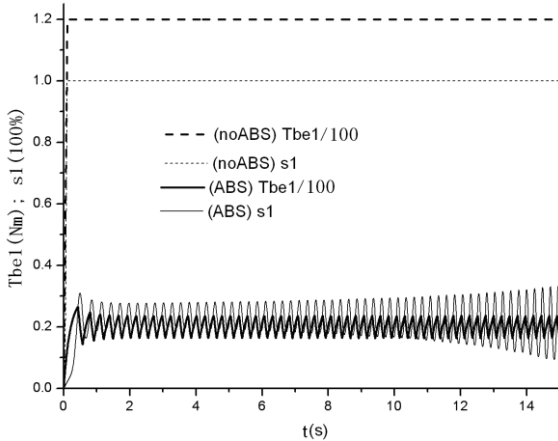

Fig. 5 The single wheel braking performance driving straightly on low adhesion condition ground

The initial vehicle velocity is set $v_0 = 120 \text{ km/h}$, the ground adhesion condition is 0.17, T_{be1} , s_1 are the left front wheel's motor braking torque and wheel slip ratio, according to those parameters two curves come out, one with ABS control, the other without ABS control. As showing in the picture, the wheel locks directly when the motor braking torque reaches 120 Nm, slip rate reaches 1

without ABS control; the single wheel control permanence with ABS control is better, the motor braking torque ranges in a small area around 20 Nm, its slip rate ranges in a small area around 0.2.

The whole vehicle ABS control performance driving straightly on low adhesion condition ground is shown in Fig. 6, the average decelerator of vehicle mass center with ABS control is bigger than that without ABS control, the mass center's side displacement and lateral angle are small in two situations, so the ABS control performance is good on low adhesion condition.

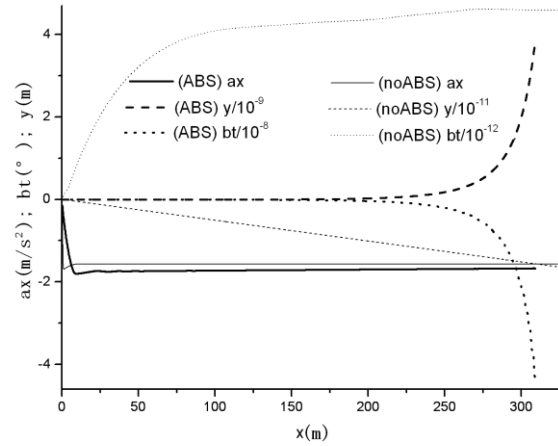

Fig. 6 The whole vehicle ABS control performance driving straightly on low adhesion condition ground

4.3. Vehicle's braking performance steering driving on a curve path

The single wheel braking performance steering driving on a curve path is shown in Fig. 7.

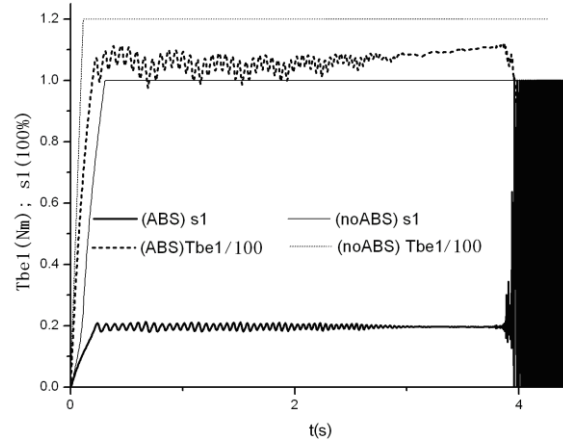

Fig. 7 The single wheel braking performance steering driving on a curve path

The initial vehicle velocity is set $v_0 = 120 \text{ km/h}$, the ground adhesion condition is 0.85, the left front wheel steering angle is 2° ; T_{be1} , s_1 are the left front wheel's motor braking torque and wheel slip ratio, according to those parameters two curves come out, one with ABS control, the other without ABS control. As showing in the picture, the wheel locks directly when the motor braking torque reaches 120 Nm, slip rate reaches 1 without ABS control; the single ABS control permanence is good with ABS control, the motor braking torque ranges between 100 and

120 Nm, its slip rate ranges in a small area around 0.2.

The whole vehicle braking performance steering driving on a curve path is shown in Fig. 8, the average decelerator of vehicle's mass center with ABS control is bigger than that without ABS control, the vehicle's mass center side displacement and lateral angle without ABS control are both bigger than those with ABS control, the vehicle without ABS control sideslips obviously, the vehicle with ABS has better control braking efficiency and stability.

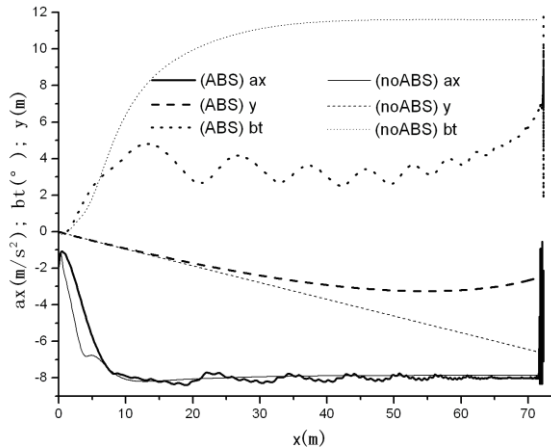

Fig. 8 The whole vehicle braking performance steering driving on a curve path

As shown in the analysis above, the regenerative braking performances with ABS control on three conditions: driving straightly on high adhesion condition ground, low adhesion condition ground and steering driving on a curve path, can fully satisfy the requirements of vehicles braking performances, the regenerative braking efficiency is higher. In the low- strength-brake, the brake friction faces do not work, the vehicle is braked by the braking generator through the feedback brake transmission component, the regenerative braking efficiency is 98.5%. In the high-strength-brake conditions, the brake friction faces work for braking, the regenerative braking efficiency is 13.38%. the brake strength increases, it can guarantee the vehicle emergent braking safety, and the regenerative braking efficiency is high in the whole vehicle running for electric vehicles.

5. Conclusion

Based on the Matlab/Simulink, establish the simulation system of regenerative braking dynamic and ABS control for the electric vehicles with the braking-driving integrated system. Based on the simulation system, respectively simulate and analyse the regenerative braking performances with or without ABS control on three conditions: driving straightly on high adhesion condition ground, low adhesion condition ground and steering driving on a curve path. Finally we can draw the conclusions as follows:

1. The regenerative braking performances with ABS control on three conditions: driving straightly on high adhesion condition ground, low adhesion condition ground and steering driving on a curve path, can fully satisfy the requirements of vehicles braking performances;

2. In the low- strength-brake, the brake friction

faces do not work, the vehicle is braked by the braking generator, the regenerative braking efficiency is 98.5%. In the high-strength-brake, the brake friction faces work for braking, guarantee the vehicle emergent braking safety the regenerative, the braking efficiency is 13.38%. So the regenerative braking efficiency is high in the whole vehicle running as the high-strength-brake conditions are fewer.

The study results indicate that the electric vehicle with the braking-driving integrated system has better ABS performances than the electric vehicle with the general brake system, and has more regenerative braking efficiency than other regenerative braking systems.

References

1. Gao, Y.M.; Chert, L.P.; Ehsani, M. 1999. Investigation of the effectiveness of regenerative braking for EV and HEV, SAE Technical Paper 1999-01-2910, <http://dx.doi.org/10.4271/1999-01-2910>.
2. Gao, Y.M.; Ehsani, M. 2001. Electronic braking system of EV and HEV-integration of regenerative braking, automatic braking force control and ABS, 2001 SAE Future Transportation Technology Conference, Costa Mesa, CA August 20-22, SAE2001-01-2478.
3. Panagiotidis, M.; Delagrammatikas, G. etc. 2000. Development and use of a regenerative braking model for a parallel hybrid electric vehicle, SAE Technical Paper 2000-01-0995. <http://dx.doi.org/10.4271/2000-01-0995>.
4. Li, S.X.; Cao, B.G.; Bai, Z.F.; etc. 2006. The experiment research on fuzzy-PI control for regenerative braking of an electric vehicle, *Electrical Engineering* 27(1): 52-54.
5. Qin, D.T.; Tan, Q.J.; Yang, Y.; etc. 2007. Simulation on regenerative braking control strategy for hybrid electric vehicle with CVT, *Automotive Engineering* 29(3): 220-225.
6. Chen, Q.Z.; He, R.; Shang, G.G. 2008. A research on integrated control of vehicle regenerative braking based on ABS, *Automotive Engineering* 30(4): 301-304.
7. Peng, D.; Zhang, Y.; Yin, C.L.; etc. 2008. Combined control of a regenerative braking and anti-lock braking system for hybrid electric vehicles, *International Journal of Automotive Technology* 9(6): 749-757. <http://dx.doi.org/10.1007/s12239-008-0089-3>.
8. Zhang, J.L.; Yin, CH.L.; Zhang, J.W. 2010. Improvement of drivability and fuel economy with a hybrid antiskid braking system in hybrid electric vehicles, *International Journal of Automotive Technology* 11(2): 205-213. <http://dx.doi.org/10.1007/s12239-010-0026-0>.
9. Tang, R.Y.; etc. 1997. *Theory and Design of Modern Permanent Magnet Motor*, Beijing: Mechanical Industry Press.
10. Wu, X.D.; Chen, L.P.; Du, A.M. 2003. Regenerative braking research for hybrid electric vehicle based on Shanghai road, *Shanghai Automobile* 32: 21-25.
11. Wang, G.Y.; Liu, G.D.; etc. 2008. Fuzzy logic direct adaptive control of ABS-equipped vehicles based on equivalent slip differential of tire chinese, *Journal of Mechanical Engineering* 11: 242-247. <http://dx.doi.org/10.3901/JME.2008.11.242>.

Guoye Wang, Hang Xiao, Juanli Zhang, Fang Wang

ENERGIJĄ ATKURIANČIOS STABDYMO ABS
KONTROLĖS TYRIMAS NAUDOJANT INTEGRUOTĄ
ELEKTRINIŲ AUTOMOBILIŲ
VAŽIAVIMO-STABDYMO GRĮŽTAMOJO RYŠIO
IŠJUNGIMO SISTEMĄ

Re z i u m ė

Straipsnyje pateiktas integruotos elektrinių automobilių važiavimo-stabdymo grįžtamojo ryšio išjungimo sistemos projektas. Integruota sistema suprojektuota ir optimizuota naudojant variklį ir diskinį stabdį. Sudarytas integruotos sistemos dinaminis modelis. Naudojant Matlab/Simulink sudaryta elektrinio automobilio su integruota važiavimo-stabdymo atsikuriančiąja stabdymo dinamikos imitavimo ir ABS kontrolės sistema. Naudojantis imitavimo sistema, atitinkamai buvo imituojamas ir analizuojamas atsikuriančiojo stabdymo veiksmas esant ABS kontrolei arba jos nesant trimis atvejais: tiesiai važiuojant per gero sukibimo gruntą, per blogo sukibimo gruntą ir važiuojant kreive. Tyrimo rezultatai rodo, kad elektriniuose automobiliuose su integruota važiavimo-stabdymo sistema ABS sistema veikia geriau nei su elektriniuose automobiliuose su įprasta stabdymo sistema ir jų atsikuriančiojo stabdymo efektyvumas, palyginti su kitomis stabdymą atsikuriančiomis sistemomis yra didesnis.

Guoye Wang, Hang Xiao, Juanli Zhang, Fang Wang

ENERGY REGENERATIVE BRAKING ABS
CONTROL RESEARCH ON FEEDBACK LOCKUP
DRIVING-BRAKING INTEGRATED SYSTEM FOR
ELECTRIC VEHICLES

S u m m a r y

Project the braking feedback lockup braking-driving integrated system for electric vehicles. Design and optimize the integrated system based on the motor and the disc brake. Set up the integrated system dynamic model. Based on the Matlab/Simulink, establish the simulation system of regenerative braking dynamic and ABS control for the electric vehicles with the braking-driving integrated system. Based on the simulation system, respectively simulate and analyse the regenerative braking performances with or without ABS control on three conditions: driving straightly on high adhesion condition ground, low adhesion condition ground and steering driving on a curve path. The study results indicate that the electric vehicle with the braking-driving integrated system has better ABS performances than the electric vehicle with the general brake system, and has more the regenerative braking efficiency than other regenerative braking systems.

Keywords: electric vehicle; regenerative braking; ABS.

Received February 21, 2011

Accepted May 30, 2012