

A new regulated method in cutter system of shield tunneling machine

Hu Shi*, Guofang Gong**, Huaiyin Liu***, Lintao Wang****

*Corresponding author, Zhejiang University Hangzhou, Zhejiang, 310027, China, E-mail: tigershi@zju.edu.cn

**Zhejiang University Hangzhou, Zhejiang, 310027, China, E-mail: gfgong@zju.edu.cn

***Zhejiang University Hangzhou, Zhejiang, 310027, China, E-mail: lhykm1985@163.com

****Zhejiang University Hangzhou, Zhejiang, 310027, China, E-mail: jixiezhixing2005@163.com

crossref <http://dx.doi.org/10.5755/j01.mech.18.4.2321>

1. Introduction

With the rapid urban development and the continuous extension of transport systems, demands of underground space exploration and tunnel construction have been considerably growing. Compared with the conventional excavation methods, the shield machine, in which the cutter system takes an important part, is famous for high efficiency and safe operation environment. Pump controlled motors have been used for many years in cutter system, taking the benefit of high power to mass ratio and high efficiency [1]. When the shield machine proceeds forward and encounters different layers of the earth, the displacement of the pump changes to meet the requirement of the system.

There used to be two control methods for changing the displacement of the pump when the shield machine is working in different conditions. First one is to control the displacement of the pump according to measured load pressure. The second one is to use load pressure directly to control the displacement of the pump. A new control method is proposed to change the displacement of the pump from one mode to another mode as soon as possible when a sudden load changes take place. In order to find the difference visually between the two methods when the shield machine enters a different layer of earth, the models of these two hydraulic systems are built in AMESim software. Using this kind of programs it is possible to realize complex system models, starting from simple sub-model already included in the program library in this system [2]. Every component has to be constituted according to the parameters of working condition, such as proportional relief valve, stroking mechanism, constant output regulation mechanism. In order to get realistic values to the parameters of different components, the related component manuals are used. In order to validate the models, it is necessary to compare simulation results as soon as possible to experimental results. In this paper also the needed test rig is described.

2. Description of the hydraulic system of cutter system

The diagram of the typical hydraulic system of a cutter of a shield machine with an open loop control is shown in Fig. 1. The direction control valve is used to change the rotation direction of the cutter, the shuttle valve is used to select the higher pressure of the two sides of the motors. This pressure and the rotation speed of the motors are the input to the controller, which controls the displacement of the pump.

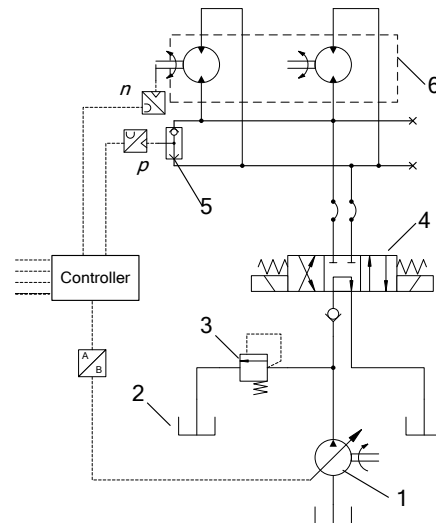

Fig. 1 Hydraulic system of the cutter system: 1 - pump; 2 - tank; 3 - relief valve; 4 - directional valve; 5 - shuttle valve; 6 - motors

When the shield machine works in a stable condition, the flow rate of the system is determined. In some applications the controller of the pump is so called constant power controller. The output flow rate of the pump is $Q = P/p$, where Q is the flow rate, P is power, p is pressure of the system. If the pressure doesn't exceed the critical pressure, the flow rate is constant. But if the load changes and the pressure is higher than the critical pressure, the flow rate of the system will change according to this equation. Fig. 2 presents the block diagram of the conventional control system of the cutter. The load pressure is measured by the pressure sensor. When the shield machine faces sudden load changes, the controller sets a new set value to the displacement of the pump. If the measured load pressure is higher than the critical pressure, the controller reduces the set value of the pump. If the measured load pressure is less than the critical pressure the set value of the pump stays constant. Considering the lag of the proportional electro-magnet, pressure sensor, converting time between the signals, it is time-consuming and can't meet the requirement of the system. When the shield machine faces sudden load changes, it may result in remarkable overloads to the system. So it is necessary to propose a new method to simplify the system and make the control system more cost effective, but still keep the system capable to response good enough different working conditions. Fig. 3 presents the principle of the new simplified control method. The proposed control method is pure hydraulics without any electronics.

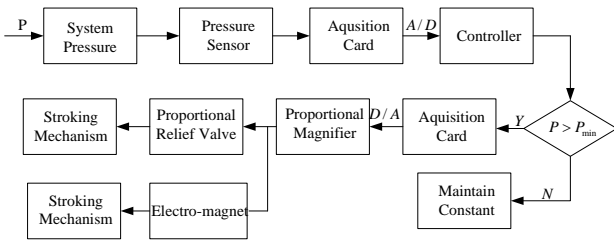

Fig. 2 The conventional control method of the cutter in constant output regulation mode

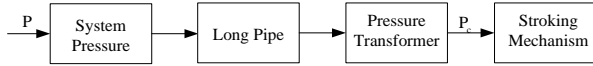

Fig. 3 The new control method of the cutter in constant output regulation mode

3. Simulation software description

AMESim is the acronym for advanced modeling environment simulations. This software is used to simulate engineering system [3]. The whole system is constituted of different submodels which can be dragged directly from the software. Different submodels can make a component through a regular arrangement and connection. When a simple system is completed, several parameters must be

defined, including mathematical description of the interaction between components and their characteristics. Then the simulation process can be started and it produces graphical and numerical representation of the behavior of the system. AMESim has different libraries, in order to get the wanted system model, in this case the control mechanical and hydraulic library are used. Sometimes the submodel can't meet all requirements, then the model have to be completed by using the hydraulic component design (HCD) library step by step, starting from the simpler components. Important part is also to find correct values for the parameters of the model. Only after verifying the results, it is possible to complete the system model.

4. Models of components

In this chapter the models of some components of the cutter system are presented.

4.1. Modelling of the pump

In the simulation, the two control methods of the pump displacement, hydraulics and electronics (Fig. 4), is compared. The parameters of the pump refer to the manual from HAWE corporation. The range of the control pressure is 0 - 32 MPa.

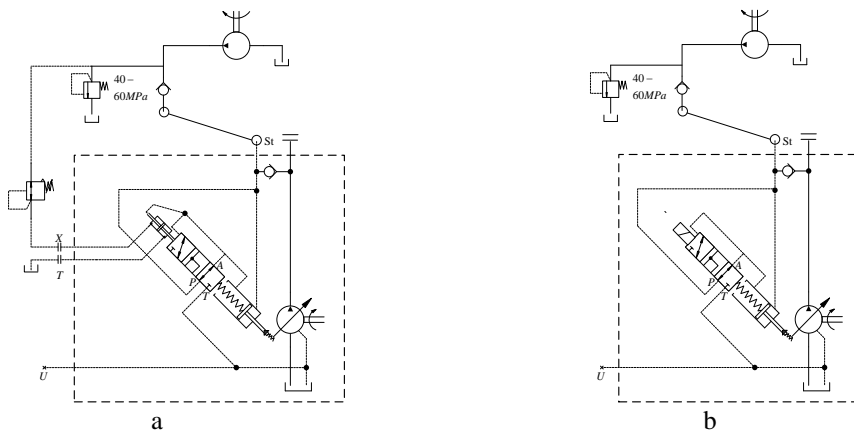

Fig. 4 The pump with the hydraulic control (a) and the pump with the electric control (b)

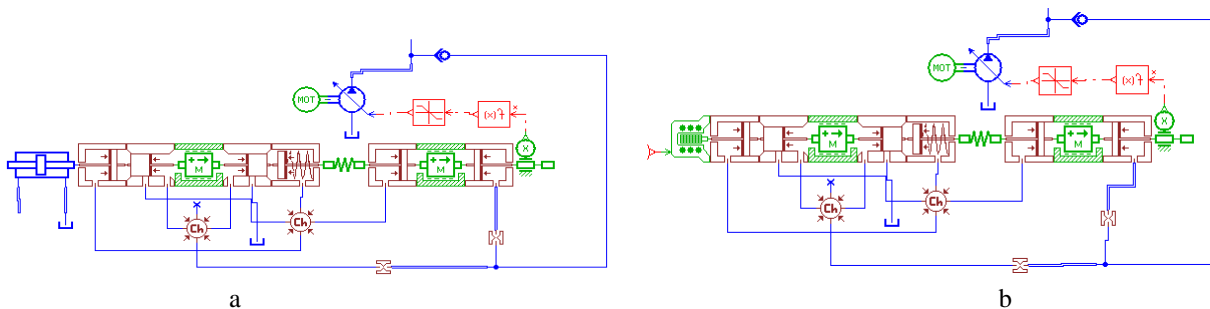

Fig. 5 Pump with hydraulic control (a) and pump with electric control (b) constituted in AMESim software

Table 1

Parameters of the pump

Names of parameters	Value	Names of parameters	Value
spool diameter, mm	10	coefficient of viscous friction, N/(m/s)	1000
rod diameter, mm	5	right spring rate, N/m	300000
mass, kg	0.02	piston diameter, mm	10
higher displacement limit, mm	0.01	rod diameter, mm	3
left spring stiffness, N/mm	600	left equivalent orifice diameter, mm	1.3
spring force at zero displacement, N	30	right equivalent orifice diameter, mm	0.5

The electric and hydraulic controlled pumps have the same parameters and structure. Based on AMESim presentation method the hydraulic control system of the pump is presented in Fig. 5. a and electric control system in Fig. 5. b. The Table 1 illustrates the parameters of the pump.

4.2. Modelling of the sensor

Considering the pipe in the shield machine is long and big, it can't be ignored about the delay of transmission and loss when the oil transmits from one point to another point. The connection pipe and the chamber make up a pressure transmission system. On the assumption that p_i is the wanted pressure which lies besides a point A, p_v is the pressure that directly acts on the membrane of the sensor. Now the membrane of the sensor is simplified to a piston with centralized mass. So the model of the sensor can be treated like what Fig. 6 illustrates.

In this model, input is p_i and output p_v . p_i and p_v conform to the following equation [4]

$$\frac{4\rho lV}{\pi\beta_c d^2} \frac{d^2 p_v}{dt^2} + \frac{128\mu lV}{\pi\beta_c d^4} \frac{dp_v}{dt} + p_v = p_i \quad (1)$$

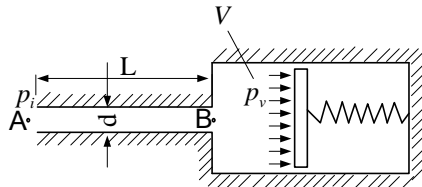

Fig. 6 Simplified scheme of the pressure measurement

Laplace transforms

$$\frac{P_v}{P_i} = \frac{1}{\frac{4\rho lV}{\pi\beta_c d^2} s^2 + \frac{128\mu lV}{\pi\beta_c d^4} s + 1} \quad (2)$$

where d is inner diameter of the pipe (m); β_c is bulk modulus of the liquid (N/m^2); V is volume of chamber (m^3); μ is absolute viscosity of the liquid (Ns/m^2); l is pipe length (m); ρ is density of the liquid (kg/m^3); t is time (s).

4.2.1. Modelling of the proportional magnet

In the hydraulic system, it can't be ignored of the influence of the electro-magnet, because it is an important part of pump and proportional valve. When the signal forces the electro-magnet to act, the dynamic force equilibrium is achieved.

Dynamic characteristic of coil current [5]

$$u_s(t) = L_d \frac{di(t)}{dt} + i(t)R(s) + K_v \frac{dy(t)}{dt} \quad (3)$$

where K_v is coefficient of the reverse EMF; R_s is resistance of the coil and the proportional magnifier; L_d is dynamic inductance of the coil.

4.2.2. Dynamic characteristic of output

The equation of the dynamic force is

$$F_d(t) = K_{Fi} i(t - \tau_d) - f_M \operatorname{sgn} \left[\frac{di(t)}{dt} \right] + F_r \quad (4)$$

where K_{Fi} is gain of the current; τ_d is time delay; f_M is delayed force of the electromagnetism; F_r is Coulombic friction.

4.2.3. Dynamic characteristic of displacement

According to the force balance of the system

$$F_d(t) = m \frac{d^2 y(t)}{dt^2} + c \frac{dy(t)}{dt} + K_s y(t) \quad (5)$$

where m is equivalent mass related to proportional magnet; c is damping ratio related to proportional magnet; K_s is spring rate related to proportional magnet.

In the system of the electro-magnet, Fig. 7 illustrates the transfer function and the control principal of the system.

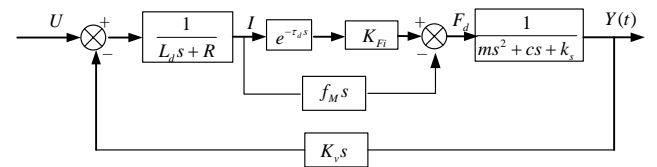

Fig. 7 Block diagram of the displacement control system

4.2.4. Modelling of the 4-way 3-position directional valve

This valve, which is used to change the flow direction of the liquid to change the direction of the cutter, is a 4-way 3-position electric controlled valve. It is a digital valve, normally closed, normally open or normally middle. According to the parameters of the valve from the manual, the valve model is shown in Fig. 8.

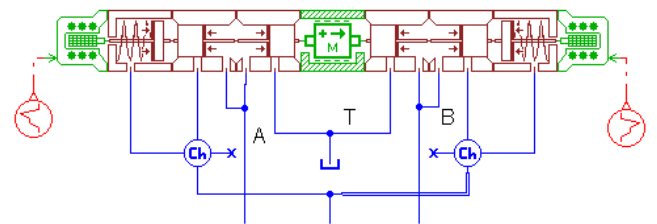

Fig. 8 Scheme of the 4-way 3-position valve

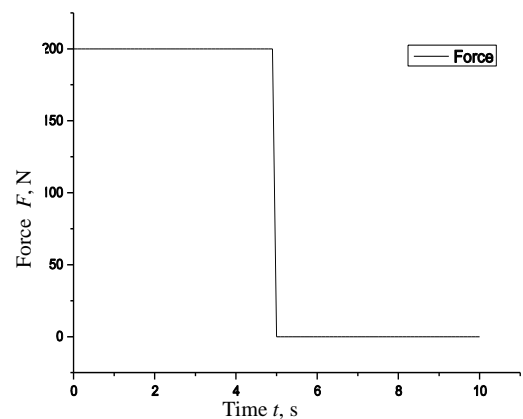

Fig. 9 Force applied by the electro-magnet

Table 2 illustrates the parameters of the valve. In this simulation, the supply flow rate is 120 L/min, the load is 50 bar. Control force and pressure in the chamber for the valve is shown in Figs. 9, 10.

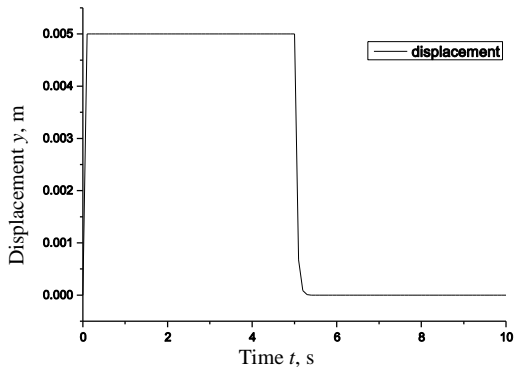

Fig. 10 The response of the spool of the valve

Table 2

Parameters of the directional valve

Name	Value
spring force at zero displacement, N	20
spring stiffness, N/mm	10
volume of chamber, cm ³	10
piston diameter, mm	10
rod diameter, mm	5
mass, kg	0.03
coefficient of viscous friction, N/(m/s)	1000

5. AMESim model of the two control methods

This paragraph describes the models of system with the two control methods. Fig. 11 illustrates the control system with electric control and Fig. 12 with hydraulic control, in which a hydraulic control valve replaces the electric control.

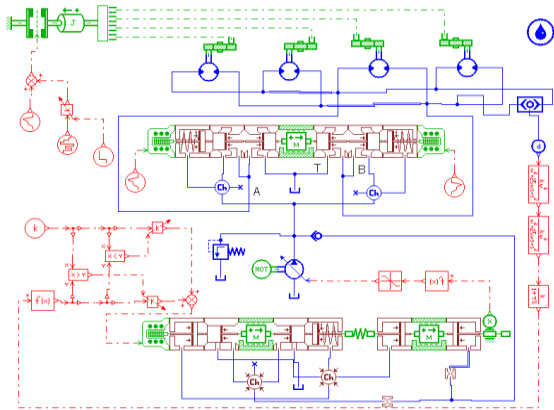

Fig. 11 The electric control method of the pump in shield machine

Fig. 13 shows the torque of the cutter system. First it is 6000 Nm and then at 3 s it changes step-wise to 27000 Nm. It can be seen from Fig. 14 that the pressure of the system with electric control is 75 bar at first and then jumps to 250 bar with a little vibration, while the pressure of the system with the hydraulic control jumps from 75 bar to 250 bar smoothly. The following Fig. 15 illustrates the result of the response of the flow rate when the pressure suddenly changes. The response time of the hydraulic con-

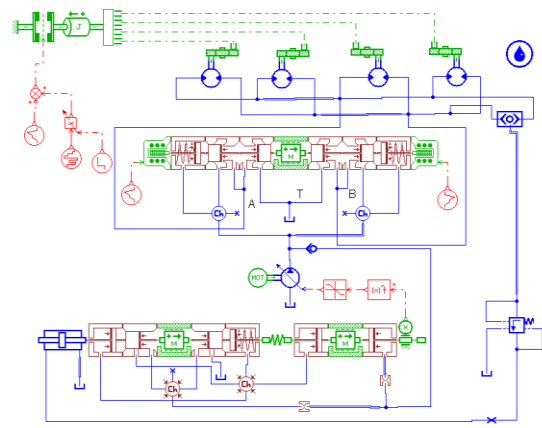

Fig. 12 The hydraulic control method of the pump in shield machine

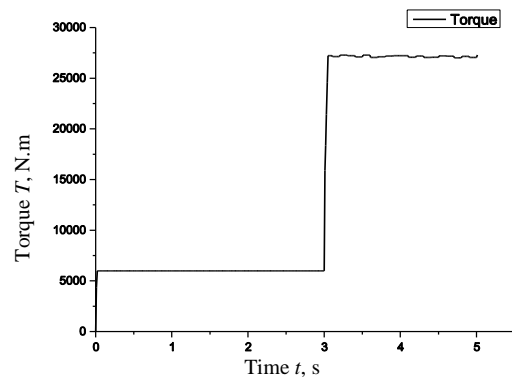

Fig. 13 Torque of the cutter system

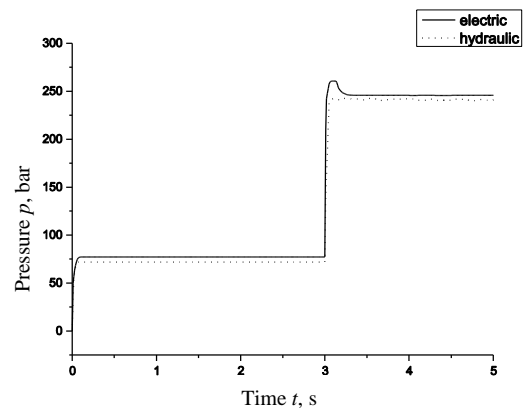

Fig. 14 Pressure of the system using the two control methods

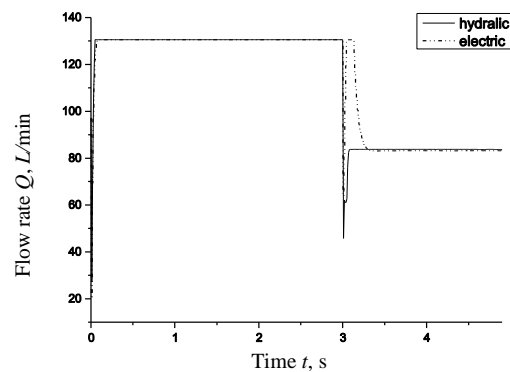

Fig. 15 Response of the flow rate of different control methods

control method is less than 0.1 s, while the other is about 0.3 s. It can be seen that the hydraulic control method responds faster than the other one and the change curve is smoother without too much vibration.

When the oil transmits through the pipe connected between the outlet of the shuttle valve and the inlet of stroking mechanism, the response of the system may have remarkable delay. Fig. 16 illustrates control principal of the hydraulic controlled system. The control oil transmits through the long line and reaches the valve. Then the oil transmits through another pipe to control the stroking mechanism to change the displacement. In order to analyze the effect of the long pipe in delaying the transmission of the signal, a long pipe model which is referring to the pipe used in the shield machine is built in AMESim. In this model, the compressibility and friction effects of the fluid are taken into account. The pipe is characterized by the diameter of 20 mm and length which ranges from 0 to 40 m. In the simulation condition, the batch run is operated by cutting the length into 5 parts in AMESim software. The simulation results are illustrated in the following diagrams. Fig. 17 illustrates the torque of the system which the system encounters in the simulation condition. At 3s, the torque jumps from 3000 Nm to 27000 Nm, which simulates different working conditions.

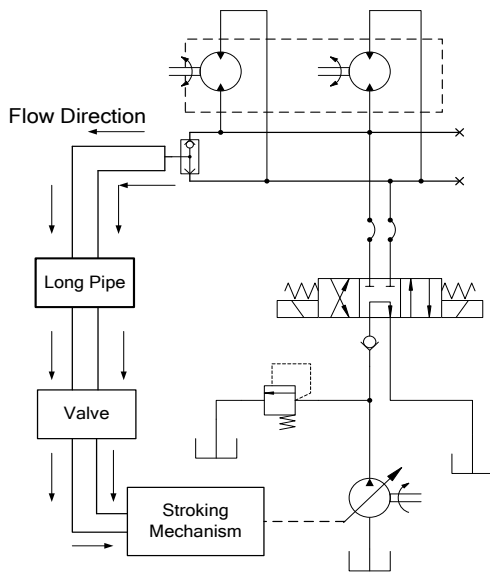

Fig. 16 The control principal of the hydraulic controlled system

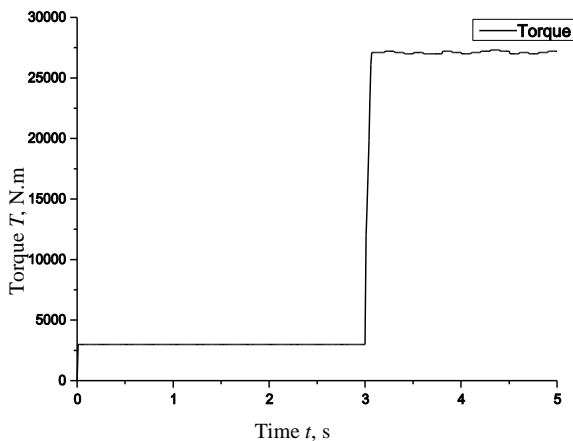

Fig. 17 Torque of the cutter system

Fig. 18 illustrates different response time of the system by inspecting the change of the pressure when the length of the pipe between the shuttle valve and the stroking mechanism is different. It can be seen from Fig. 18 that when the length of pipe ranges from 0 to 40 meters, the response time ranges from 0.1 s to 0.7 s. The longer the pipe is, the slower the response of the system is. It can be seen from Fig. 19 that when the length is different, the dynamic response of the flow rate of the system is different. When the length is small, the flow rate of the system has a little vibration. When the length becomes bigger, the response of the flow rate is smoother. The longer the pipe is, the bigger the damping ratio of the system is, so it will affect the stability and the response of the system. Compared with the preceding electric controlled method, when the length of the pipe is small, the hydraulic control method is advantageous in the aspect of the response time. When the length of the pipe is longer than about 20 meters, the response of the hydraulic control method may be slower than the other one.

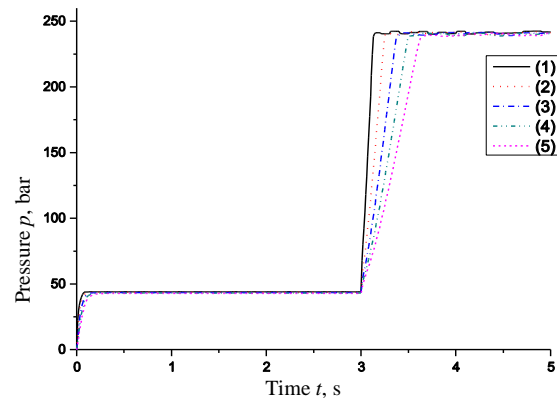

Fig. 18 Pressure of the cutter system

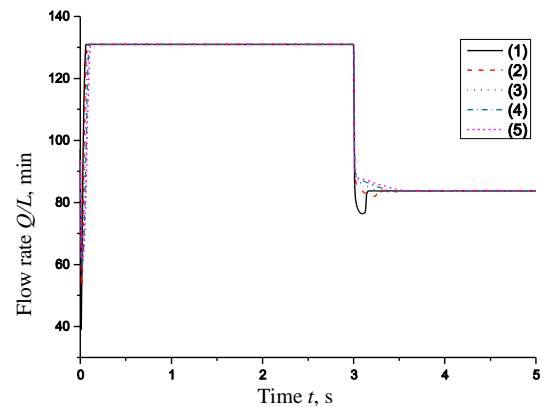

Fig. 19 Flow rate of the cutter system

6. Experimental test rig for the characterize of the system

To validate the simulation models, it is important to compare simulations with experimental data provided by appropriate test rigs. The test rig has been built, which include a pump with different control methods, proportional relief valve, pressure sensor and flow meter, etc. In this system, a motor, whose ports are connected with the proportional relief valve, is used to simulate the load the shield machine may encounter. By regulating the pressure of the proportional relief valve, which ranges from 0 to



Fig. 20 Valve group of the system (a) and simulation load equipment (b)

315 bar, we can simulate different working torque. Fig. 20, a illustrates the valve group of the system and Fig. 20, b illustrates the motor and the pump which connect through an inertia wheel.

7. Conclusions

1. Based on the working principal of the cutter system of the shield machine, a new control method for the change of the displacement of the pump is proposed. When the pump works in the constant output regulation mode, the simulation result demonstrates that it is possible to control the displacement by the hydraulic control and is advantageous and swift to fit the flow rate with the needs of the system.

2. The length of the pipe between the shuttle and the pump is also taken into account in affecting the response time of the system. The simulation results show that when the pipe is shorter than a definite value, the response time of hydraulic control method is faster than the other one. Also, the new method will cut down the cost of the system, because it will reduce a lot of conversion devices which change the hydraulic signal to electric signal. Through the simulation, it proves feasible to use the method to change the flow rate of the system in order to avoid the overloading of the motors and improve the response of the pump to act. In the future, the control effect will be testified and compared with the conventional control methods in the experiment.

References

1. **Xing Tong; Li Xilian; Gong Guofang; Yang Huayong.** 1987. Contribution to modeling and simulation of an electro-hydraulic control system in shield machine, IEEE Translated J. Fluid Power, China, 2: 740-741, [Proceedings of the Fifth International Symposium on Fluid Power Transmission and Control].
2. **Bdlforte, G.; Carello, M.; Ferraresi, C.; Martinelli, M.; Pescarmona, F.; Viktorov, V.** 2008. Modeling and identification methodology of components for train braking system, IEEE Translated J. Fluid Power in motion. Dresden, 5: 393-405, [Digest 6th International Fluid Power Conference. Fluid Power in motion Dresden, p. 301, 2008].
3. AMESim User Manual, Version 4.2, 2004.
4. **Huang Changyi; Yan Puqiang** 2005. Testing Basis of Mechanical Engineering, China Machine Press, 207-209.
5. **Wu Genmao; Qiu Xiumin; Wang Qingfeng; Wei Jianhua; Kong Xiaowu; Fu Xin,** 2006. Electrohydraulic Proportional Technique in Theory and Application, Zhejiang University Press, 92-93.

Huaiyin Liu, Goufang Gong, Hu Shi, Lintao Wang

NAUJAS SKYDINĖS TUNELINĖS MAŠINOS PJOVIMO SISTEMOS REGULIAVIMO METODAS

R e z i u m ė

Šiame straipsnyje nagrinėjama, kaip pagerinti skydinės mašinos pjoavimo sistemos reagavimą į staigius apkrovimo pokyčius. Analizuojant įprastus siurblio išdėstymo kontrolės metodus, buvo pasiūlytas naujas tiesioginio kontrolės ir reguliavimo metodas. Imitavimo rezultatai parodė, kad naujam kontrolės metodui būdingas trumpesnis reagavimo laikas ir geresnės dinaminės charakteristikos, reaguojant į staigius skydinės mašinos apkrovimo pokyčius ir sistemos slėgio šuolius nuo 7 iki 25 MPa. Vamzdžio tarp šaudyklinio vožtuvo ir siurblio ilgis taip pat turi įtakos sistemos reagavimui.

Hu Shi, Huaiyin Liu, Guofang Gong, Lintao Wang

A NEW REGULATED METHOD IN CUTTER SYSTEM OF SHIELD TUNNELING MACHINE

S u m m a r y

This paper is focused to improve the responses of the cutter system of the shield machine to sudden load changes. By analyzing the conventional control method of the displacement of the pump, a new control method named as hydraulic controlled and regulated direct method is proposed. The simulation results show that the new control method has a shorter response time and better dynamic behavior, when the shield machine encounters sudden load changes and the system pressure jumps from 7 to 25 MPa. The length of the pipe between the shuttle valve and the pump is also taken into account in affecting the response of the system.

Keywords: cutter system, shield tunneling machine.

Received March 11, 2011

Accepted June 13, 2012