

Study of wear prediction by applying surface microgeometric parameters

V. Jankauskas, R. Kreivaitis

Lithuanian University of Agriculture, Studentu 15, 53362 Akademija, Kauno r., Lithuania,
E-mail: vytenis.jankauskas@lzuu.lt

1. Introduction

Abrasive wear being one of the most intensive wear types is constantly analysed and simulated with aim to predict and increase machine elements life by choosing materials and their processing technologies [1].

The properties of abrasives are affected by material, shape and size of the particles. On the process of wear abrasiveness of the particles varies – their edges are blunted, disintegrating particles result in sharp edges. For this reason wear is assessed by both surface wear and abrasive particle properties variation.

A customary parameter of abrasive properties assessment is the particle size which directly affects the wear. Yet this rule is not applicable to the particles smaller than 100 μm [1, 2] because of varying sharpness of their edges and not the varying contact pressure. As confirmed by theoretical models, bigger particles are more angular shape than the smaller one [3, 4]. Whereas the optical estimation of particles indicates that angularity of aluminum oxide Al_2O_3 particles does not vary at their sizes being 1, 10, and 100 μm [1].

The particle shape is a critical parameter affecting abrasive wear. It is intended to introduce a parameter for assessing abrasive properties which could be used for setting up theoretical abrasive and erosion wear models [5]. The most common parameters combining abrasive particles shape and size are the ratios of particle width to length – W/L and its perimeter to area – P^2/A . It is proved that abrasive and erosion wear intensifies with an increase in P^2/A and a decrease in W/L ratios [1] which allow only a qualitative comparison of abrasive properties of the particles. This method is rather inaccurate and is recommended for preliminary estimation only.

The other parameter assessing the shape of abrasive particles is that of spike (SP) [1, 5, 6]. It is based on measuring the abrasive particle irregularities by isosceles triangles, Fig. 1.

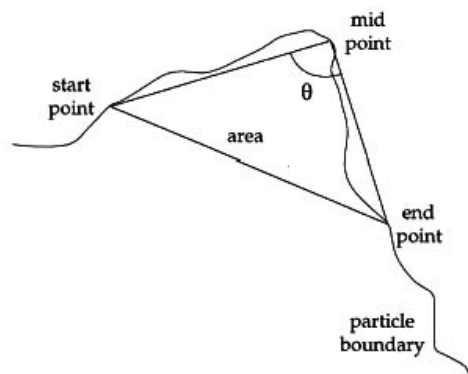

Fig. 1 Estimation of SP parameter by an isosceles triangle

The measurement steps – distance between the start and end points are chosen according to the particle shape (Fig. 1). Isosceles triangles are scratched on particle irregularities by these steps. The measured particle irregularity is assessed by triangle area A and apex angle θ . The greater the irregularity the greater the triangle area, and accordingly, the angle is more acute - when particle edges are sharper.

The sharpness and size of triangle can be described by a numerical parameter called the “spike value” sv , the parameter assessing one particle irregularity and varying from 0 to 1 is obtained [5]

$$sv/h = \cos(\theta/2) \quad (1)$$

where θ is angle of triangle apex; h is altitude of the triangle.

The particle surface is measured several times by the steps of different magnitudes. When measuring, the highest sv/h value is separated, these magnitudes are marshaled and having calculated the average the spike parameter SP of the particle is obtained.

This value may be practically used in mathematical models of abrasive wear. When particles become acute, the wear intensifies and the obtained spike parameter gives a rather accurate description of the wear variation [5]. Disadvantages of this method are - much time is wasted for measuring of the particles and calculating their parameters. It is insufficiently accurate because all surface irregularities are measured irrespective of small heights and pits which have no real effect on the contact [1].

The spike parameter – quadratic SPQ fit (Fig. 2) is more accurate [1, 5, 7]. Assessing the spike by means of this method, an imaginary particle center is chosen and marked $(x; y)$, the circumscribed circle radius r is estimated. It is more likely that the particle surface lying behind the boundaries of this circle will interact with its surface while the irregularities in inner circle are “inactive”. Therefore external surfaces of the particle are estimated (spikes of apexes are estimated by a maximum radius (r_{max})). A spike between the points $sp - mp$ and $mp - ep$ can be expressed by a square polynomial. Differentiation of the polynomials at the mp point yields the apex angle θ and the spike value sv , i.e. $sv = \cos \theta/2$. The SPQ is then calculated according to the formula

$$SPQ = sv_{average} \quad (2)$$

One of the basic SPQ merits (compared to the SP method) is that the particle irregularities of the most likely contact are assessed. This method is more common, not requiring much time for measurement and calculations.

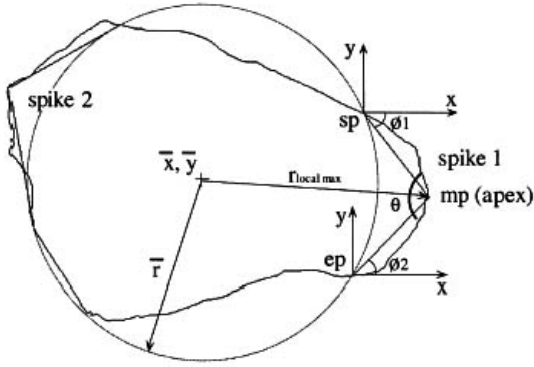

Fig. 2 Estimation of the SPQ parameter of an abrasive particle

The obtained accuracy is experimentally evaluated [5].

It is not sufficient to assess the abrasive particle shape parameters, its penetration into the flat surface under loading is to be evaluated. This method embodies two principle methods of evaluation. The first method – Cone-Fit Analysis (CFA) is more suitable for the theoretical conception of the process, while the second supplementing the first one introduces closer indices under real conditions [1, 8, 9].

Both methods are similar, they are based on the theoretical Rabinowicz method, i.e. the interaction model between a precise cone shape particle and the surface, Fig. 3 [1, 8].

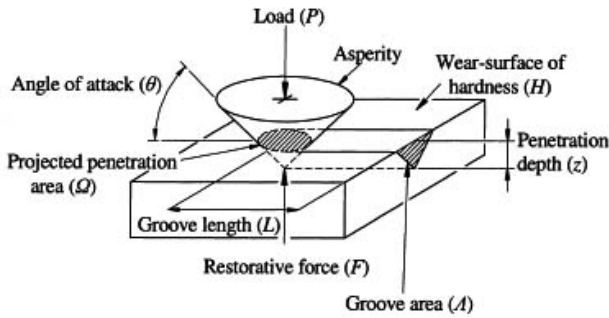

Fig. 3 Interaction between a cone shape particle and flat surface

While wearing, the surface is subjected to load P , the angle of attack θ and wear surface hardness H resisting to their effect. Their interaction is estimated by two basic parameters: groove area A and projected penetration area Q . The ratio of these parameters for the cone shape and pyramid shape particles is a constant value independent of the scratched groove depth [1, 8].

The projected penetration area can be measured by the initial parameters (surface hardness and load) or by the groove geometric parameters obtained during the process [8]

$$\Omega = P/H = \pi \omega^2 \quad (3)$$

where ω is semiwidth of the groove.

Both the size of an abrasive particle and the angle of attack have an effect on the groove area [8]

$$A = \omega^2 \tan \theta \quad (4)$$

where θ is angle of attack.

Assuming that the metal of a scratched groove is removed by micro cutting, wear can be calculated by the equation [8]

$$V = \frac{FL \tan \theta}{\pi H} \quad (5)$$

where L is length of the scratch.

Referring to these equations the wear can be predicted by the CFA method. Firstly, using a special computer program Ω and A parameters of the particle are estimated and their mean ratio is calculated λ_{av} . The obtained values are assessed to correlate with the wear results quite accurately [1, 8].

With an increased number of abrasive particle edges the scatter of the results also increases and, especially under greater loads the theoretical and real conditions do not coincide [8, 9].

Sharpness analysis (SA) supplementing the CFA method makes it possible to estimate that, practically the particle shapes are not accurate. For this reason the ratio of the scratch cross-section area to the particle surface area is not a constant magnitude [1, 9] resulting in the differences in the models evaluating theoretical and real conditions. To confirm the SA method, the particles exterior has been analysed, the shape of abrasive particles has been described by square equations and the wear has been studied [1, 9]. The obtained relation is limited, i.e. it is valid only at relatively moderate forces and penetrations.

In addition to the mentioned means, the methods based on scan and computer evaluation are being developed [10].

When setting up the abrasive wear models the major problem to be solved is the evaluation of probable agents and their stability [11, 12]. The surfaces wear under elastic or plastic deformation and also under micro-cutting. Under a minor load the abrasive particle slides and runs along the surface deforming it elastically [12, 13]

$$d'/2R < 9.22[H_w/E_m]^2 \quad (6)$$

where d' is depth of the scratch (Fig. 4); R is radius of abrasive particle; H_w is hardness of the surface; E_m is modulus of elasticity of the surface under deformation.

When an abrasive particle is deforming the surface by the magnitude $d' \leq 18.44[H_w/E_m]^2 R$, the surface is elastically reformed. This deformation is related to mechanical properties of the materials and it differs for different surfaces. Very hard (brittle) surface may crumble without being deformed [11].

With an increase in the ratio of contact pressure to wearing surface hardness, the scratch deepens and the elastic deformation turns into plastic. When sliding, the particle pushes the metal of the scratch into its sides causing plastic hardening of both the groove bottom and pushed out metal bumps (Fig. 4). Mathematical expression of this process is

$$9.22[H_w/E_m]^2 < d'/2R < 0.029 \quad (7)$$

This formula (7) is perfectly suited for the alloys of monolithic structure when a sliding abrasive particle

quasi acts monolithic alloy. Simulation of the abrasive wear of hard layers with carbides scattered in a seemingly soft matrix of an alloy is rather complicated task. Two versions are probable: the first when the abrasive particle slides over hard surfaces of alloy constituents without penetrating into the matrix, the second, when the hard alloy crumbs are pushed out to the scratch sides or they are crumbed in its bottom. They both depend on the ratio of alloy matrix and crumbs hardness and the size to their quantities in the alloy.

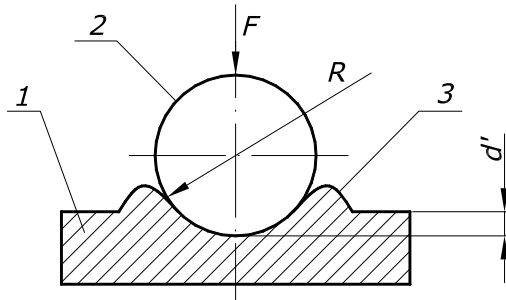

Fig. 4 Surface under plastic deformation: 1 – wearing surface; 2 – abrasive particle; 3 – bump of pushed out metal

The wearing surface acquiring the other values of hardness and the modulus of elasticity, the equilibrium of Eq. (7) will change and micro-cutting of some parts of the surface is then expected [11, 14]. Special attention is given to the transition of these processes in their mathematical descriptions. Regrettably, when presenting their research the authors give a rather general description of their research conditions, thus making it difficult to choose the reasonably best model.

Research objective – is to examine the relationship between the wear value and microgeometric parameters of the wear surface of electroarc welded hard layers (Fe-C-Si-Cr-B) of different hardness carbon steels.

2. Testing procedures

To estimate the effect of the surface microgeometric parameters on its wear, carbon grade 45 steel (GOST 1050-88) and tool grade XBГ steel (GOST 5950-73) were used. To obtain different hardness values the steels were thermally treated. Their chemical composition is given in Table 1.

Table 1
Chemical composition of 45 and XBГ steels

Steel mark	Chemical composition, %				
	C	Si	Mn	Cr	W
45	0.42...0.50	0.17...0.37	0.50...0.80	≤0.25	-
XBГ	0.90...1.05	0.10...0.40	0.80...1.10	0.90...1.20	1.20...1.60

To evaluate the abrasive wear of hard layers, the samples of different composition manually welded by electric arc spread electrodes were used. Chemical composition of the layers examined by spectral analyzer Belec Compact Laboratory is given in Table 2. The effect of chromium amount on that of carbon was achieved due to some scalding process characteristics (with the decrease in chromium

amount that of carbon decreases).

Measuring the wear surfaces of hard layers it was noticed that the wear traces of hard and abrasive wear resistant layers were smooth while those of scarcely abrasive resistant layers were rough with sharp scratches (grooves) left by abrasives.

Table 2
Chemical composition and hardness of samples welded with hard layers of varying chromium content

Coating code	Chemical composition, %						Hardness, HRC
	C	Si	Mn	Cr	Ti	B	
Cr1	3.14	1.76	0.74	36.7	0.27	0.655	44
Cr2	2.83	2.79	1.18	20.8	0.78	0.718	51
Cr3	2.96	2.50	1.14	17.7	0.73	0.722	60
Cr4	2.56	2.37	1.31	16.5	0.90	0.705	58
Cr5	2.23	2.34	1.19	9.7	0.83	0.733	59
Cr6	1.95	2.01	1.02	6.2	0.78	0.705	60
Cr7	1.45	1.79	1.03	1.7	0.60	1.2	50

A hypothesis for assessing wear by wear trace parameters is suggested. This assessment method would be preliminary and useful in cases when mass decrease between different samples is too small to consider it reliable. An additional parameter would make it possible to evaluate the obtained results more accurately and also to predict them. It would allow to decline the wear evaluation by the mass method when either the mass of wearing element is big or its disassemble is too complicated.

The profiles of wear surfaces are described by profilometer HOMMEL TESTER T 500. The profile of a wear trace is measured perpendicularly to the abrasive motion direction. The result is estimated by standard roughness parameter R_a and SPQ_P parameter [1, 15]. The SPQ_P parameter evaluates the surface profile with respect to the irregularities shape [1, 15]

$$SPQ_P = \frac{1}{n} \sum_n \cos \frac{\theta_i}{2} \quad (8)$$

where n is the number of measured irregularities at a chosen distance; θ_i is measured angle of the i th irregularity apex (Fig. 5).

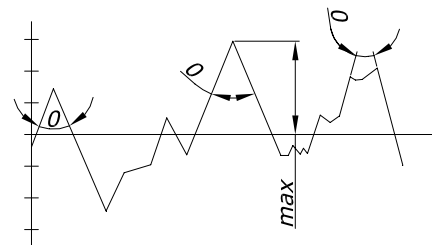

Fig. 5 Assessment of the surface profile by the SPQ_P parameter [1, 15]

On measuring, a basic measurement distance is chosen. The irregularities which are exclusively over the mid line are evaluated. The largest irregularities in the chosen distance are determined. The irregularities smaller than 25 % of the maximum height are not evaluated.

Having measured the apexes angles of the irregu-

larities, the SPQ_p parameter is obtained by using Eq. (8). The sharper the surface irregularities, the closer the SPQ_p value is to 1.

Abrasive wear is evaluated according to the standard ASTM G65-94 [16]: $F = 130$ N, $v = 2.4$ m/s, $t = 600$ s, by applying 200-425 μm fraction quartz sand (250-300 g/min) on the friction surface.

The wear of samples is evaluated by the method of masses weighing the samples on the analytical scales SCALTEC SBC 32 (with accuracy of 0.1 mg) prior and post the testing. Tempering and thermal treatment are performed in the furnace MII-2YM. Hardness of the samples is measured by hardness meter TK-2M.

3. Experimental results and discussions

The layers containing small amount of chromium (Cr7, Cr6, Cr5 samples) wear more intensively because of insufficient quantity of hard phase. While wearing, fine carbides are simply broken by abrasive particles acting the surface. The highest resistance to wear is reached with 16-18% chromium amount in the welded layer (Cr4, Cr3 samples).

Abrasive wear of different hardness thermally treated steels has been investigated. The examination results of steels hardness, their wear and geometric parameters are given in Table 3.

Table 3

Microgeometric parameters of wear-out and wear trace surface of thermally treated grade 45 and grade XBG steels

Sample	Hardness, GPa	Wear, g	Angle θ , degree	SPQ_p	R_a , μm
45	5.7	0.0906	12.3	0.975	1.16
	5.4	0.0990	14.8	0.963	1.16
	4.3	0.1158	15.6	0.959	1.08
	2.7	0.1592	19.6	0.939	1
	1.6	0.1509	21.3	0.926	1.14
XBG	6.5	0.0705	10.9	0.980	1.36
	6.2	0.1018	11.8	0.978	1.1
	5.7	0.0998	13.9	0.968	1.12
	3.3	0.1296	15.8	0.960	0.98
	2.5	0.1181	15.1	0.963	1.24

The investigation into the wear traces of different hardness steels has not revealed the apparent differences in surface profiles. Fig. 6 presents the profilograms of wear traces of maximum and minimum hardness surfaces of grade XBG steel.

The surface profile of a harder sample (Fig. 6, a) has more sharp edged irregularities than a more worn down softer sample (Fig. 6, b). The evaluated SPQ_p parameter has confirmed it (Figs. 7 and 8).

The above given diagrams indicate that wear-out of grade 45 steel and tool grade XBG steel with a probability of 88% and 76%, respectively, has a direct influence on the microgeometry of the wear trace surface.

It might be caused by uneven wear of the surfaces of different hardness. In softer surface, wearing the abrasive particles are considered to deform it stronger, thus leaving no sharp edged spikes. On the contrary, in hard surfaces wearing, the wearing appears as a fatigue surface destruction because of repeated elastic and plastic defor-

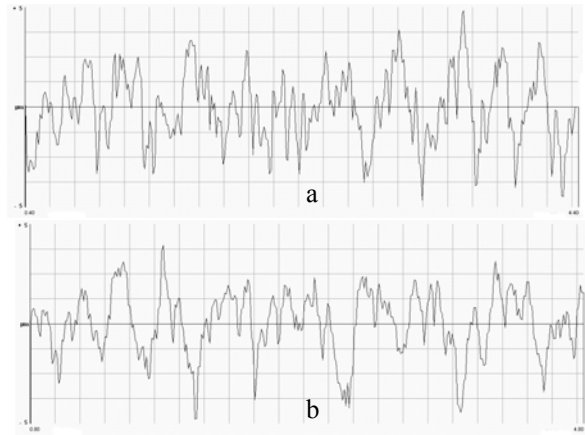

Fig. 6 Profilograms of wear traces of thermally treated tool grade XBG steel surfaces: a- maximum hard – 6.5 GPa, b- minimum hardness – 2.5 GPa

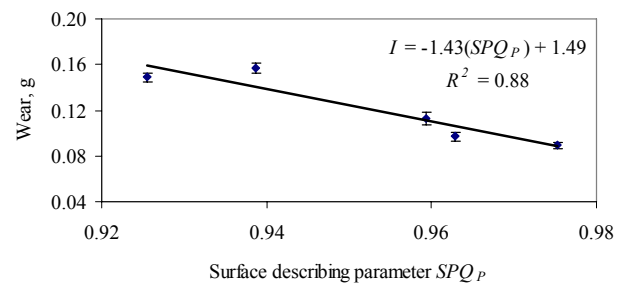

Fig. 7 Interaction between the surface microgeometric parameter SPQ_p and the wear-out of different hardness grade 45 steel

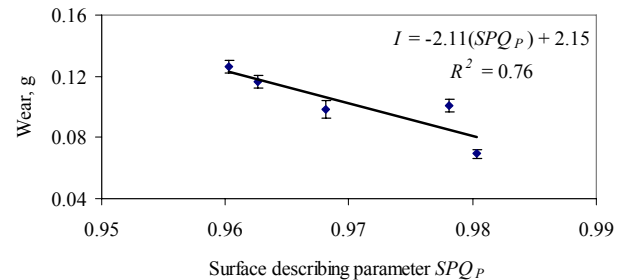

Fig. 8 Interaction between the surface microgeometric parameter SPQ_p and the wear-out of different hardness tool grade XBG steel

mations. Crumbling off surface particles leave sharp edged irregularities. The standard roughness assessment parameter R_a does not present a reliable difference in worn surfaces of different hardness of grade 45 and XBG steels.

Having investigated resistance to abrasive wear of welded layers, the difference in profiles of the wear surface traces is evident. It is illustrated by profilograms of worn surfaces in Fig. 9. The parameters evaluating wear-out and roughness of the wear trace surface are given in Table 4.

In contrast to thermally treated steels, the welded layers have indicated a more explicit difference in worn surface profiles. The surfaces more resistant to abrasive wear are smoother ($R_a=0.38-0.58$ μm), their surface is flatter, surface irregularities are blunter. A closer relation between the wear-out and the roughness parameters – R_a and SPQ_p is noticed.

Fig. 10 illustrates the influence of wear of welded layers on the SPQ_p parameter of wearing surface. The

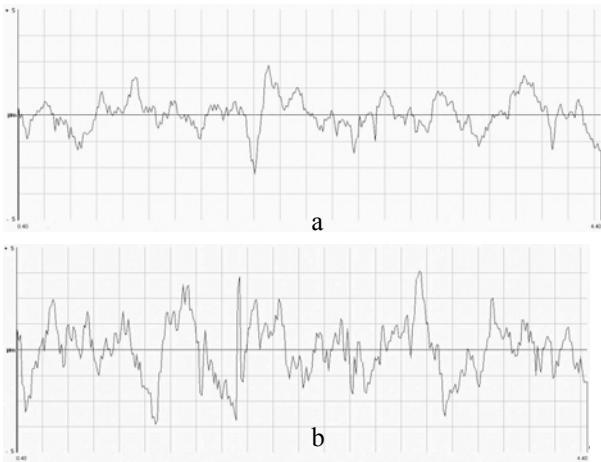

Fig. 9 Profiles of wear traces of welded layers surfaces containing different amount of chromium a - maximum resistant to abrasive wear and b - minimum resistant to abrasive wear

SPQ_P parameter directly describes the relation between the wear-out value and the wearing surface profile with a probability of 89%.

The comparison of the wear influence of thermally treated steels and welded layers on the wearing surface profile demonstrates that an increasing wear of steels has an effect on the decrease in the SPQ_P parameter, whereas, on the contrary, an increasing wear in welded layers also increases the value of the SPQ_P parameter. In both cases the wear visibly influences the wearing surface profile, but this influence is inversely proportional.

Table 4
Microgeometric parameters of hard layers wear-out and wear trace surface

Coating code	Hardness, GPa	Wear, g	Angle θ , degree	SPQ_P	Roughness R_a , μm
Cr1	4.7	0.0277	23.9	0.909	0.90
Cr2	5.6	0.0253	27.1	0.882	0.64
Cr3	7.1	0.0228	30.0	0.855	0.58
Cr4	6.6	0.0191	31.2	0.851	0.38
Cr5	7.0	0.0271	28.8	0.863	0.40
Cr6	7.1	0.0344	23.2	0.910	0.64
Cr7	5.5	0.0480	13.5	0.969	1.08

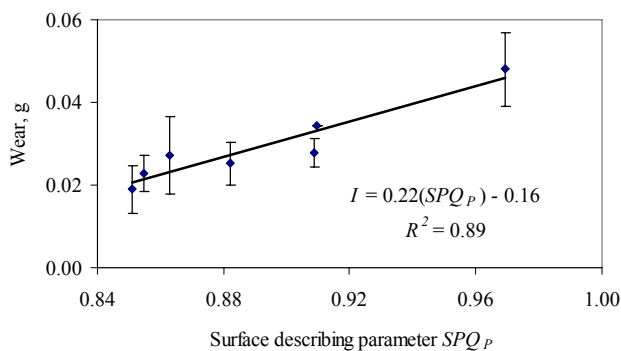

Fig. 10 Influence of the hard layers wear-out on the surface microgeometric parameter SPQ_P

This interaction may be caused by a different mechanism of the wear. Thermally treated steels are relatively of equal hardness in the whole volume, while the

welded layers are formed of carbides from a matrix. This difference in structural composition stipulates their wear characteristics.

4. Conclusions

1. Abrasive wear of different hardness steels and welded hard (Fe-C-Si-Cr-B) layers has a direct relation to microgeometric parameters of the wearing surface. As concerns different wear mechanisms, this influence is opposite;

2. Parameter SPQ_P describes the variation of wear with 76...89% probability, therefore having set up the data base of various steels with analogous parameters, the parameter SPQ_P can be applied for assessing the wear of the elements working under the same conditions.

References

1. **Stachowiak, G.W.** Wear – Materials, Mechanisms and Practice. -England: John Wiley & Sons Ltd, 2005. -458p.
2. **De Pellegrin, D.V., Stachowiak, G.W.** Assessing the role of particle-Shape and scale in abrasion using “Sharpness Analysis”, Part II – technique evaluation. -Wear, 2002, Nr.253, p.1026-1034.
3. **Xie, Y., Bhushan, B.** Effects of particle size, polishing pad and contact pressure in free abrasive polishing. -Wear, 1996, Nr. 200, p.281-295.
4. **Gahlin, R., Jacobson, S.** The particle size effect in abrasion studied by controlled abrasive surfaces. -Wear, 1999, Nr.224, p.118-125.
5. **Stachowiak, G.W.** Particle angularity and its relationship to abrasive and erosive wear.-Wear, 2000, Nr.241, p.214-219.
6. **Hamblin, M.G., Stachowiak, G.W.** A multiscale measure of particle abrasivity and its relation to two body abrasive wear.-Wear, 1995, Nr.190, p.190-196.
7. **Stachowiak, G.W., Stachowiak, G.B.** Wear mechanism in boll-cratering tests with large abrasive particles. -Wear, 2004, Nr. 256, p.600-607.
8. **Stachowiak, G.W., De Pellegrin, V.D.** A new technique for measuring particle angularity using cone fit analysis. -Wear, 2001, Nr. 247, p.109-119.
9. **Stachowiak, G.W., De Pellegrin, V.D.** Sharpness of abrasive particles and surfaces. -Wear, 2004, Nr.256, p.614-622.
10. **Richerson, D.W.** Modern Ceramic Engineering; Properties, Processing and Use in Design.- 2nd - edition.- England, 1992.-841p.
11. **Gorana, V.K., Jain, V.K., Lal, G.K.** Force prediction during material deformation in abrasive flow machining. -Wear, 2006, Nr.260, p.128-139.
12. **Torance A. A.** Modeling abrasive wear.- Wear, 2005, Nr.258, p.281-293.
13. **Shipway, P.H.** A mechanical model for particle motion in the micro-scale abrasion wear test. -Wear. -2004, Nr.257, p.984-991.
14. **Fang, L., Liu, W., Du, D., Zhang, X., Xue, Q.** Predicting three-body abrasive wear using Monte Carlo methods. -Wear, 2004, Nr.256, p.685-694.
15. **Hamblin, M.G., Stachowiak, G.W.** Description of surface abrasivity and its relation to two – body abrasive wear. -Wear, 1997, Nr.206, p.69-75.

16. ASTM G65-94, Standard test for measuring abrasion using the dry sand/rubber wheel apparatus, 1996 Annual Book of ASTM Standards, Volume 03.02, ASTM.

V. Jankauskas, R. Kreivaitis

NUDILIMO PROGNOZAVIMO, NAUDOJANT PAVIRŠIŲ MIKROGEOMETRINIUS PARAMETRUS, TYRIMAS

Re z i u m ė

Straipsnyje atlikta abrazyvinio dilimo vertinimo metodikų apžvalga. Dilimo spartai įtakos turi šie parametrai: abrazyvų medžiaga, dalelių dydis, forma, kontaktinis slėgis ir kt. Dauguma naudojamų abrazyvinio dilimo spartos vertinimo modelių pagrįsti elementarios dalelės ir paviršiaus sąveika, t. y. mikropojovimu šalinamos metalo dalelės nustatymu. Tačiau pakitus dilimo sąlygoms esami modeliai tampa netikslūs. Tą lemia kontaktinių paviršių apkrovų dydžio pokytis ir kt. veiksniai. Patikimiausiu dalelių abrazyvumo vertinimo parametru laikomas abrazyvo dalelės SPQ parametras. Atlikti eksperimentiniai termiškai apdoroto anglinio 45 ir įrankinio ХВГ plienų bei kietųjų (Fe-C-Si-Cr-B) sluoksnių abrazyvinio dilimo tyrimai pagal ASTM G65. Dilimo paviršių mikrogeometrinio parametro SPQ_p palyginimas su paviršių nudilimu parodė esant patikimą ($R^2=76-89\%$) sąveiką tarp nudilimo ir parametro SPQ_p verčių. Todėl galima teigti, kad parametras SPQ_p gali būti naudojamas preliminariam nudilimui vertinti tais atvejais, kai mašinų elementai, yra pagaminti iš vienos medžiagos, tačiau skirtingai termiškai apdoroti ir naudojami vieno abrazyvo terpėje.

V. Jankauskas, R. Kreivaitis

STUDY OF WEAR PREDICTION BY APPLYING SURFACE GEOMETRIC PARAMETERS

S u m m a r y

The paper presents the review of abrasive wear assessment methods. Wear intensity is influenced by material, size and shape of particles, contact pressure, etc. Most models of abrasive wear intensity assessment are based on the interaction between an elementary particle and the surface i.e. on the estimation of a metal particle removed by microcutting. Under changing wear conditions, the present

models become inaccurate due to alteration of the load values of contacting surfaces and other factors. The most reliable parameter of particles abrasivity is considered the abrasive particle parameter SPQ . Thermally treated carbon grade 45 and tool grade ХВГ steels and hard (Fe-C-Si-Cr-B) layers have been experimentally investigated according to ASTM G65. Comparison of the microgeometric parameter SPQ_p of wear surfaces to the surfaces wear-out has exhibited reliable interaction ($R^2=76-89\%$) between the values of wear and parameter SPQ_p . For this reason the parameter SPQ_p can be used for assessing preliminary wear-out in the cases when machine elements are made of one material and are used in one abrasive medium, but with different thermal treatment.

В. Янкаускас, Р.Крейвайтис

ИССЛЕДОВАНИЕ ВОЗМОЖНОСТИ ПРОГНОЗИРОВАНИЯ ИЗНОСА ИСПОЛЬЗУЯ МИКРОГЕОМЕТРИЧЕСКИЕ ПАРАМЕТРЫ ПОВЕРХНОСТИ

Р е з ю м е

На интенсивность абразивного изнашивания влияет материал, величина, форма абразивных частиц, их давление на изнашиваемую поверхность и др. Большинство моделей прогнозирования абразивного изнашивания учитывают процесс микрорезания поверхности и являются вполне приемлемыми в определенных условиях, изменение которых дает большие погрешности. Это связано с изменением степени влияния пластического деформирования / микрорезания на процесс изнашивания. Наиболее надежным параметром оценки абразивных свойств частиц является их параметр SPQ . Проведены экспериментальные исследования абразивного изнашивания сталей 45, ХВГ и твердых наплавленных слоев разной твердости согласно требованиям ASTM G65. Анализ величины износа и шероховатости поверхности взаимосвязи не показал. Но расчетный параметр поверхности SPQ_p и величина износа имеют достаточно высокую взаимосвязь ($R^2=76-89\%$). Эта зависимость может успешно применяться для предварительной оценки износа сталей, термически обработанных на различную твердость.

Received September 03, 2007