

Alignment of the parts using high frequency vibrations

E. Sadauskas*, B. Bakšys**

*Kaunas University of Technology, Kęstučio str. 27, 44312 Kaunas, Lithuania, E-mail: edvardas.sadauskas@stud.ktu.lt

**Kaunas University of Technology, Kęstučio str. 27, 44312 Kaunas, Lithuania, E-mail: bronius.baksys@ktu.lt

crossref <http://dx.doi.org/10.5755/j01.mech.19.2.4164>

1. Introduction

Assembly of peg-in-hole type parts are very common in automated assembly. Main tasks of parts feeding to the working area, positioning, alignment, insertion and removal of the assembled parts from working area must be fulfilled to complete assembly process. Vibrations of industrial equipment, manufacture errors of the parts, robot/manipulator positioning errors are the main reasons of axes misalignment between mating parts. This could result in insertion failure since the connecting surfaces of mating parts don't match each other. Assembly time may increase as well as costly equipment could be damaged. During alignment parts are oriented relatively to each other so their connective surfaces matches. This process increase reliability and effectiveness of automated assembly.

At the moment active, passive and combined methods for mutual part alignment are used. Feedback from the force/moment sensors are used to adjust position errors in active alignment systems [1, 2]. Some other approaches use vision based systems [3]. However drawback of active alignment is its complexity since sophisticated electronics for positioning sensing or technical vision as well as actuators is used. Not always possible to determine misalignment direction from sensor feedback or because of the complexity of assembled parts vision system inappropriate since they occluding a good view [4.]. Also active alignment systems are more costly than passive ones.

Passive alignment devices don't use feedback from the sensor and servo actuators. They are designed in such a way that reactive forces between mating parts adjust their relative position. Devices with remote center of compliance (RCC) have resilient elements whom deforms under contact forces between the peg and the bush [5]. Reaction force that arises in a contact adjusts position of the peg so it can match with joining surfaces. A device with RCC is simple and effective tool for part alignment, but it's suitable only for chamfered parts and only for insertion in vertical direction.

In auto search systems one of the parts has systematically explore planar neighbourhood where axis misalignment exists [6]. Different search trajectories like concentric circles, interwinding helix or random path can be implemented. It is experimentally approved that average alignment time is 7,1 s when interwinding helix search path is used with the peg of 99,5 mm diameter and hole is 100 mm diameter.

Now day's vibrations have a wide range of applications. Piezoelectric motors, vibration-assisted machining, vibrotransportation as well as vibratory alignment all of them are based on distinctive effect of vibrations on an object or work piece. Vibratory alignment also refers to

passive alignment systems. It's a promising technology because of their structural simplicity and good performance quality. They can be used together with RCC devices or like stand-alone systems. Performing vibratory auto search, the plane vibrates horizontally in two orthogonal directions and the mobile based bush makes circular motion on it [7]. To obtain interwinding helix trajectory the peg is pressed to the bush with progressively increasing force. Experimentally is determined that excitation frequency and amplitude has the most influence on the size of the search field. When excitation frequency and/or amplitude increases, search field also increases.

Vibratory alignment when immovable based bush excited in axial direction and the peg is attached to the resilient element is investigated in work [8]. It is determined that alignment duration was mostly effected by the excitation frequency and amplitude when chamfered parts with rectangular and circular cross-section were used. The area of excitation and system parameters sets have been define where parts alignment is stable.

In all vibratory technics mentioned above parts are excited with a low frequency (up to 100 Hz) vibrations and mating parts oscillates as a rigid bodies. New method of part alignment when the part vibrates at a high frequency as an elastic body is analysed in the article. The peg is fixed in a gripper and the piezoelectric vibrator is pressed to the upper end of the peg. Bush in mean time is mobile based on a plane. After the peg is excited in axial direction on one end, not only longitudinal but also lateral vibrations are generated at the other end of the peg [9, 10]. The tip of the peg is moving in elliptical shape trajectory in a horizontal plane since lateral vibrations aren't strictly polarized. When mating parts has axis misalignment and the peg is pressed to the bush, friction force arises and the bush is moving to the center of the peg. Such method is suitable for the chamferless parts with different cross-sections. The most important is to set proper dynamic system parameters (excitation frequency and amplitude, bush-to-peg pressing force) to have alignment process stable and reliable.

2. Experimental setup and method of vibratory part alignment investigation

Experimental setup was designed and made to investigate part alignment when elastic vibrations were applied to the peg (Fig. 1). The peg is fixed in a gripper 8. Gripper can move in vertical direction in order to insert peg into the bush when alignment occurs. Spring 7 works as gravity force compensator for the gripper and helps to capture the moment as the peg falls into the bush hole. By moving table 6 vertically pressing force of mating parts is adjusted. The table is moved horizontally in order to

change axis misalignment which is measured with indicator 9. Low frequency signal generator 3 provides signal to the piezoelectric vibrator. The amplitude and frequency of the signal are measured by multimeter 1. Switch 5, oscillo-

scope 4 and personal computer 2 are used for alignment event triggering and alignment duration measurement respectively.

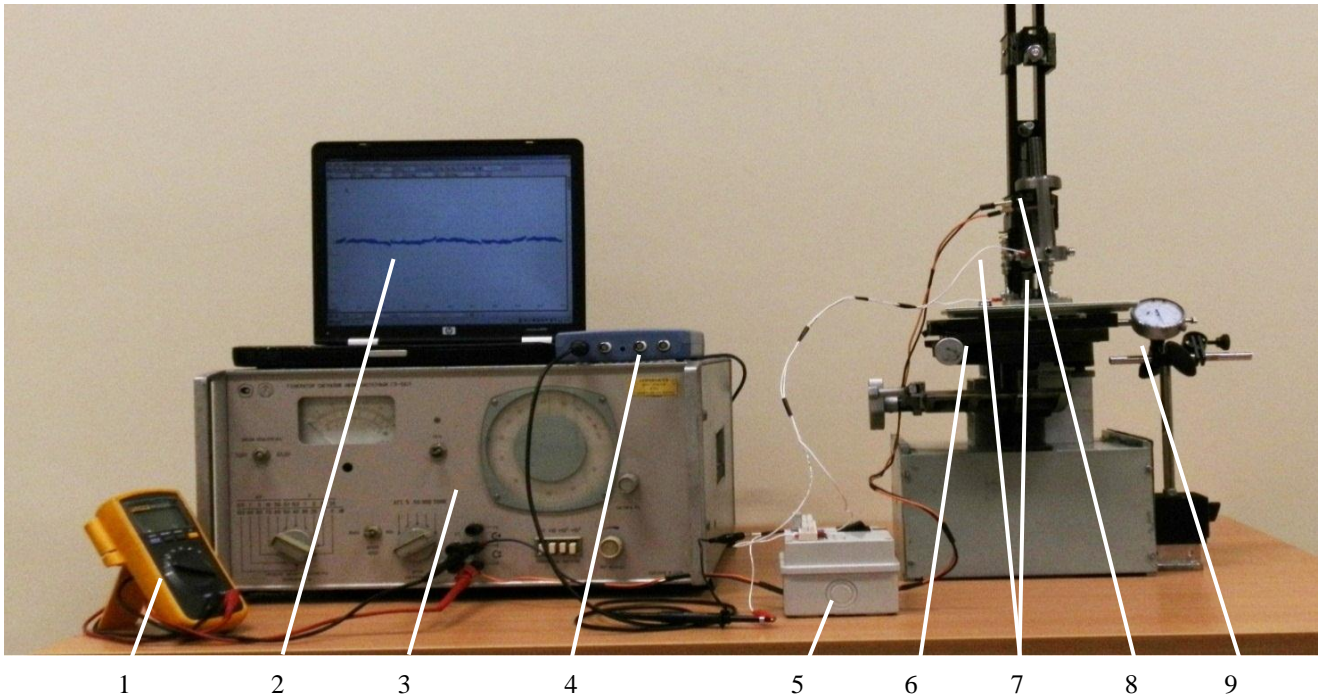

Fig. 1 Experimental setup: 1 – multimeter; 2 – computer; 3 – signal generator; 4 – oscilloscope; 5 – switch; 6 – table; 7 – spring; 8 – gripper; 9 – indicator

The peg 4 is hold in a middle cross-section by the clamps of the gripper (Fig. 2). Piezoelectric vibrator 5 is implemented in a housing 6. The end of the housing is threaded and can freely rotate in a gripper at the same time performing linear motion towards the peg.

As the piezoelectric vibrator lean to the peg, further torque increment sets pressing force for the piezoelectric vibrator to the peg. Bush 3 is mobile based on the electrically conductive plate 2 while the latter is located on the force sensor 1. The bush, plate, and force sensor are fixed to the table and moves together.

Electrical circuit was designed to measure the alignment time (Fig. 3).

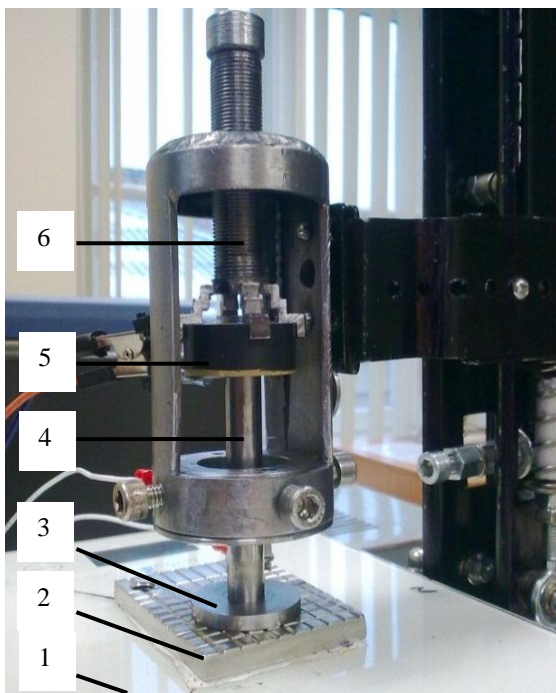

Fig. 2 Close view of the gripper: 1 – force sensor; 2 – plate; 3 – bush; 4 – peg; 5 – piezoelectric vibrator; 6 – housing

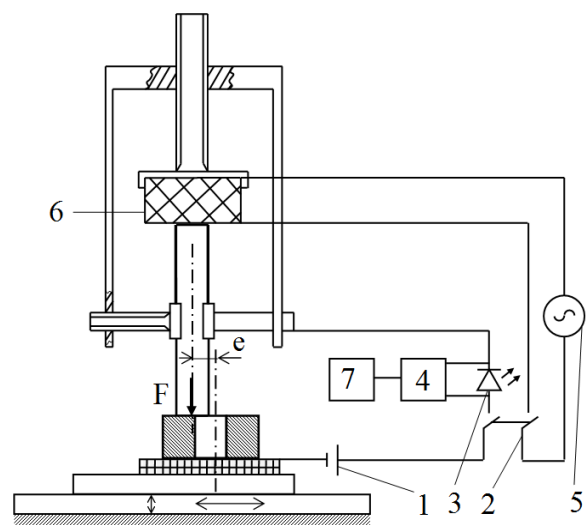

Fig. 3 Measurement circuit: 1 – 9 V power supply; 2 – switch; 3 – light-emitting diode (LED); 4 – oscilloscope; 5 – signal generator; 6 – piezoelectric vibrator; 7 – computer

Anode of the power supply 1 connected to the electrically conductive plate. Cathode first connected to the switch 2 and LED 3 and later to the gripper. Oscilloscope 4 is measuring voltage signal on the LED. When the switch closes electrical circuit, the voltage jump on the LED occurs. At the same time excitation signal from generator 5 is connected to the piezoelectric vibrator 6. As the bush slides to the peg's center, intermittent mechanical contact between them is created. Electrical signal also becomes intermittent. When alignment between peg and the bush occurs, there is no mechanical contact between them and the voltage jump on the LED is the lowest. Measured signal transferred to the computer 7 and by mean of the software alignment time is calculated (Fig. 4).

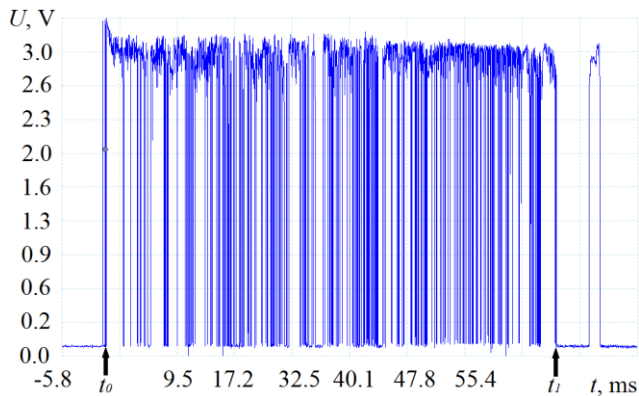

Fig. 4 Alignment process oscillogram: t_0 – start of the alignment t_1 – end of the alignment

At the moment t_0 excitation signal is activated and alignment process is started. Voltage jump in oscillogram indicates its beginning. During time the bush slides towards the peg, measurement signal is intermittent because of the peg's longitudinal vibrations. As the alignment occurs at time t_1 there is no mechanical contact between mating parts and the measurement signal is the lowest. Alignment duration is calculated:

$$\Delta t = t_1 - t_0.$$

During investigation the peg is excited in axial direction by mean of cylindrical shape piezoelectric vibrator with 30 mm in diameter and 13 mm in height. Pressing force vibrator-to-peg is set to 101 N and kept constant throughout the experiments. Harmonic excitation signal of certain frequency and amplitude is generated by low frequency generator.

Each time experiment repeated four times and a mean value of four trials is taking as a result. Influence of axis misalignment e , excitation frequency ν , excitation amplitude A and initial peg-to-bush pressing force F to the alignment duration Δt is investigated. Experiments were carried out with steel and aluminium pegs with circular (C) and rectangular (R) cross-sections and their counterparts steel and aluminium bushings. The alignment of rectangular parts was done along short side of the peg. The parts were both type with chamfers and with no chamfers. Measurements of the parts used in experiments are given in Table.

Material and geometrical data on specimens

Peg	Hole	Cross-section	Chamfers
Steel S235JR			
$D_{iameters}, mm$	L_{length}, mm	$D_{iameters}, mm$	C
10	99.75	10.1	C
10	79.65	10.1	C
10	59.8	10.1	C
7.95	99.85	8.05	C
5.95	99.6	6	C
Aluminium SAPA6082-T6			
10	99.95	10.05	C
10	99.95	10.05	C
Steel S235JR			
$L_{length} \times W_{width} \times H_{height}, mm$	$L_{length} \times W_{width}, mm$		
10.1 × 5.3 × 99.3	10.4 × 5.45	R	No
10.05 × 5.1 × 99.5	10.4 × 5.45	R	0.33 × 49°

3. Experimental results and evaluation

The dependencies of alignment duration Δt on axis misalignment e is presented in Fig. 5. Steel peg with diameter of 10 mm and length of 99.75 mm is excited under different excitation frequency and initial pressing force F . Excitation amplitude $U = 142$ V is same to all investigated pegs.

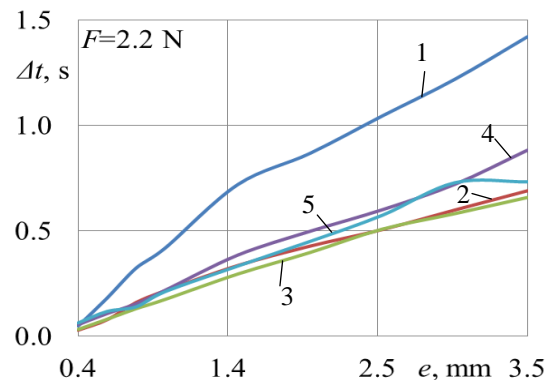

Fig. 5 Alignment duration dependency on misalignment e : 1 – $\nu = 7000$ Hz; 2 – $\nu = 7050$ Hz; 3 – $\nu = 7100$ Hz; 4 – $\nu = 7150$ Hz; 5 – $\nu = 7200$ Hz

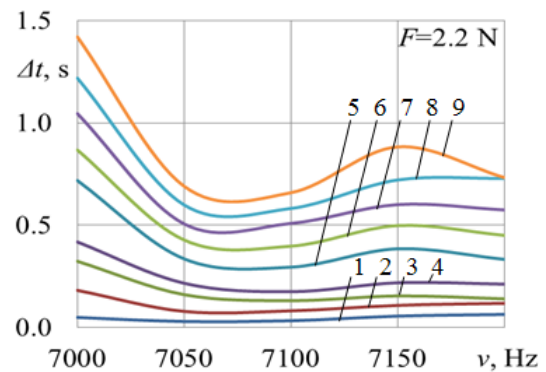

Fig. 6 Alignment duration dependency on excitation frequency ν : 1 – $e = 0.4$ mm; 2 – $e = 0.6$ mm; 3 – $e = 0.8$ mm; 4 – $e = 1.0$ mm; 5 – $e = 1.5$ mm; 6 – $e = 2.0$ mm; 7 – $e = 2.5$ mm; 8 – $e = 3.0$ mm; 9 – $e = 3.5$ mm

It is determined that alignment duration increases as axis misalignment increases. The character of a graph is linear and don't depend on excitation frequency. However excitation frequency has significant influence to the alignment duration (Fig. 6).

The alignment of the parts is most rapid when excitation frequency is between 7050-7100 Hz and this trend visible under different axis misalignment. As frequency changes from these values, alignment duration increases. It was also determined that for a small axis misalignment (up to 1 mm) the influence of excitation frequency is negligible.

Excitation frequency at which alignment of the parts is most rapid increases as geometrical dimensions of the peg decreases. But size of the peg is not the only reason of frequency changes. Contact quality between peg and piezoelectric vibrator plays significant role in an excitation frequency. More is the area the end surface of the peg touches vibrator, more acoustic energy transferred to it, as well as excitation frequency is lower. During experiments was noticed that end surface of smaller diameter peg was harder to make parallel to the end surface of the vibrator. That circumstance should be taken in consideration making any conclusions on excitation frequency using smaller diameter pegs.

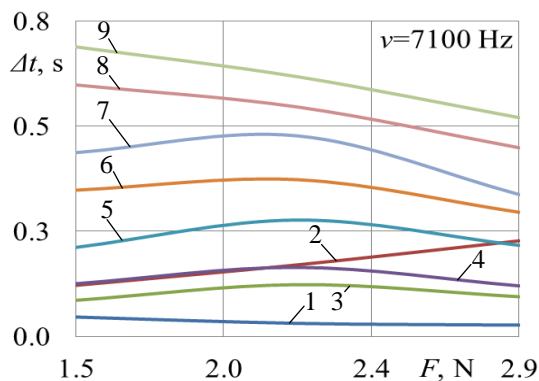

Fig. 7 Alignment duration dependency on force F :
 1 – $e = 0.4$ mm; 2 – $e = 0.6$ mm; 3 – $e = 0.8$ mm;
 4 – $e = 1.0$ mm; 5 – $e = 1.5$ mm; 6 – $e = 2.0$ mm;
 7 – $e = 2.5$ mm; 8 – $e = 3.0$ mm; 9 – $e = 3.5$ mm

Fig. 7 represents dependencies of alignment duration Δt on initial pressing force F under different axis misalignment. Influence of initial pressing force on alignment duration is relatively small when axis misalignment is up to 1 mm. In a case when $e > 1$ mm alignment duration decreases as force F increases.

During experiments with aluminium pegs and bushings was noticed that alignment goes not so fast as with steel ones. This is related with material properties of the specimens. Dry friction coefficient is higher between aluminium parts than between steel ones. Also aluminium is softer material than steel thus it deforms easier and damps vibrations. Excitation frequency is also approximately 1 kHz higher than using steel pegs of same size. Fig. 8 presents alignment duration comparison of aluminium pegs with chamfers and without it at different axis misalignment e .

The biggest axis misalignment what is possible to compensate is 2.5 mm when peg without chamfers and 3.5 mm with chamfered peg. The character of the graph is no longer linear in the case with chamfered peg. The

smallest axis misalignment at which is still appropriate to use elastic vibrations for the mutual part alignment is 0.8 mm. If misalignment is smaller parts aligns because of the surface interaction between bush and the chamfer after the initial pressing force is applied without usage of vibrations.

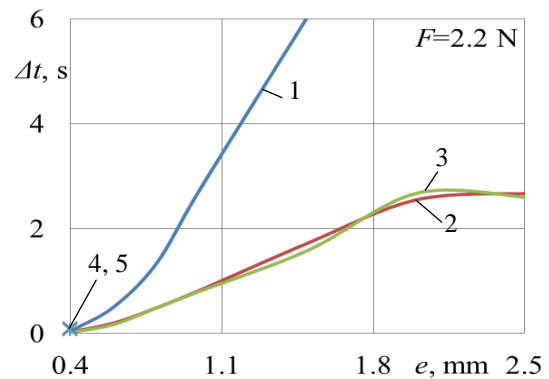

a

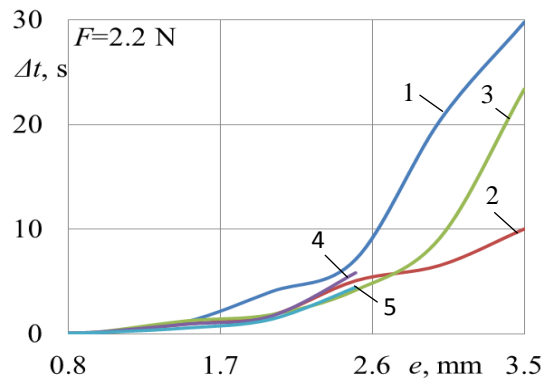

b

Fig. 8 Alignment duration dependency on misalignment e :
 a – peg without chamfers: 1 – $\nu = 8400$ Hz;
 2 – $\nu = 8450$ Hz; 3 – $\nu = 8500$ Hz; 4 – $\nu = 8550$ Hz;
 5 – $\nu = 8600$ Hz; b – peg with chamfers:
 1 – $\nu = 7750$ Hz; 2 – $\nu = 7800$ Hz; 3 – $\nu = 7850$ Hz;
 4 – $\nu = 7900$ Hz; 5 – $\nu = 7950$ Hz

Influence of excitation frequency on alignment duration for the chamferless and chamfered pegs is presented in Fig. 9. It is experimentally approved that alignment process is most rapid at 8500 Hz in case with chamferless peg and 7800 Hz in case with chamfered peg. It is also determined that maximum axis misalignment of 2.5 mm compensated when excitation frequency is in a range between 8450 and 8500 Hz for the chamferless peg. 3.5 mm of axis misalignment compensated in a frequency range between 7750 and 7850 Hz for the chamfered parts.

Like with the steel pegs (Fig. 6), the character of the graphs of the aluminium pegs are parabolic. And the influence of the excitation frequency is greater when $e > 0.6$ mm when peg without chamfers is used and $e > 2$ mm when peg has chamfers

For the chamferless peg alignment duration constantly increases as initial pressing force vary from 1.5 N to 2.2 N. Furthermore increase in initial pressing force stops alignment process. In case when chamfered peg is used, the alignment duration is minimal at 2.2 N initial pressing force. If the pressing force increases or decreases

from that value, alignment duration also slightly increases. But if $e < 1.5$ mm the influence of initial pressing force to the alignment duration is negligible.

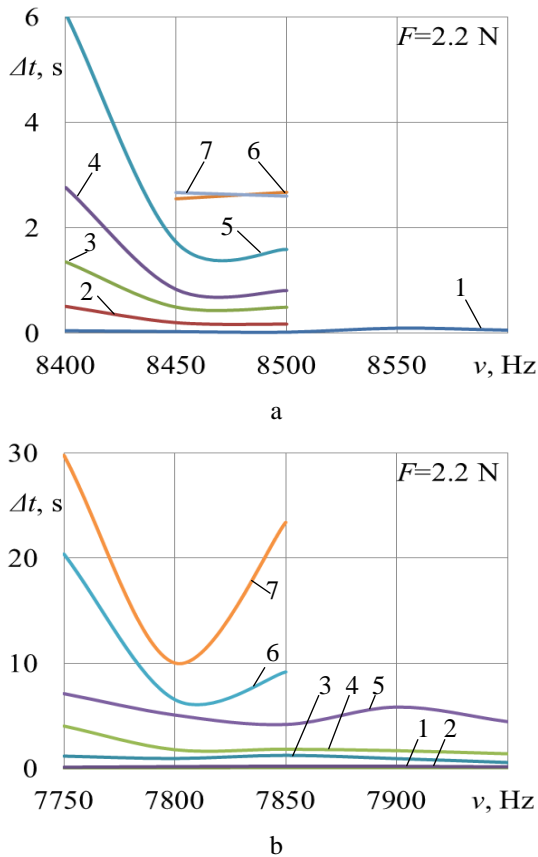

Fig. 9 Alignment duration dependency on excitation frequency ν : a – peg without chamfers; b – peg with chamfers: 1 – $e = 0.4$ mm; 2 – $e = 0.6$ mm; 3 – $e = 0.8$ mm; 4 – $e = 1.0$ mm; 5 – $e = 1.5$ mm; 6 – $e = 2.0$ mm; 7 – $e = 2.5$ mm; 8 – $e = 3.0$ mm; 9 – $e = 3.5$ mm

Experiments with rectangular cross-section steel pegs were also carried out, the results of which are presented in Figs. 10 and 11. We can see that maximum axis misalignment that is compensated is equal to the half of the short side of the peg if peg has no chamfers while in case with chamfered peg, axis misalignment up to 3.5 mm is compensated (Fig 10, a, b). The character of the graph is not linear in both cases.

Minimal e at which is still appropriate to use vibrations for the part alignment is 0.6 mm. If axis misalignment is smaller than 0.6 mm, parts alignment occurs under initial pressing force without applied vibrations.

Dependencies on alignment duration versus excitation frequency are similar as for the steel or aluminium pegs. If misalignment e is up to 0.8 mm, alignment duration slowly decreases while excitation frequency increases. However maximum alignment duration is at the frequency 6950 Hz. When $1.0 \leq e \leq 1.5$ mm the duration Δt increases if frequency increases. And only in a small frequency range between 7050–7100 Hz possible to make alignment when axis misalignment more than 1.5 mm.

In case with chamfered peg, alignment process is fastest at frequency 7500 Hz, when $e > 2.5$ mm. But if axis misalignment is more than 2.5 mm frequency at which

alignment process is most rapid is shifted to the higher frequency region.

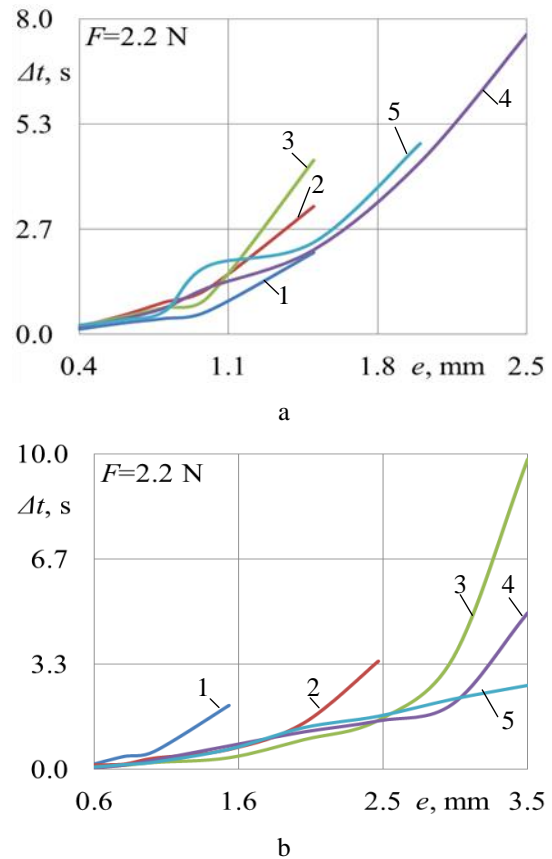

Fig. 10 Alignment duration dependency on misalignment e : a – peg without chamfers: 1 – $\nu = 6900$ Hz; 2 – $\nu = 6950$ Hz; 3 – $\nu = 7000$ Hz; 4 – $\nu = 7050$ Hz; 5 – $\nu = 7100$ Hz; b – peg with chamfers: 1 – $\nu = 7400$ Hz; 2 – $\nu = 7450$ Hz; 3 – $\nu = 7500$ Hz; 4 – $\nu = 7550$ Hz; 5 – $\nu = 7600$ Hz

Fig. 11, a represents influence of initial pressing force F to the alignment duration Δt for the chamferless peg. As pressing force increases from 1.5 N to 2.2 N alignment duration decreases rapidly. Furthermore increase of the pressing force decreases alignment duration but at much smaller scale. This tendency is valid if $e \geq 0.8$ mm. If axis misalignment is more than 0.8 mm alignment process goes under pressing force more than 2 N. But alignment duration still decreases if pressing force increases.

Alignment duration is most rapid at pressing force 2.2 N when peg with chamfers is used, (Fig. 11, b). If force decreases or increase from that value, alignment duration increases. And only in case when axis misalignment is 3.5 mm, alignment duration most rapid at pressing force of 2.9 N.

Influence of excitation signal amplitude to Δt is shown in Fig. 12. All pegs were chamferless and around 100 mm in length. Diameter of circular pegs was 10 mm while cross-section of rectangular peg had dimension of 10.5×5.45 mm. Initial pressing force was 2.2 N.

In a case of circular steel peg, Fig. 12, a, alignment duration decreases while amplitude increases when $e < 2.5$. Only when signal amplitude is 80 V we can see small increase in alignment duration. If axis misalignment is more than 2.5 mm, stable alignment duration decrease

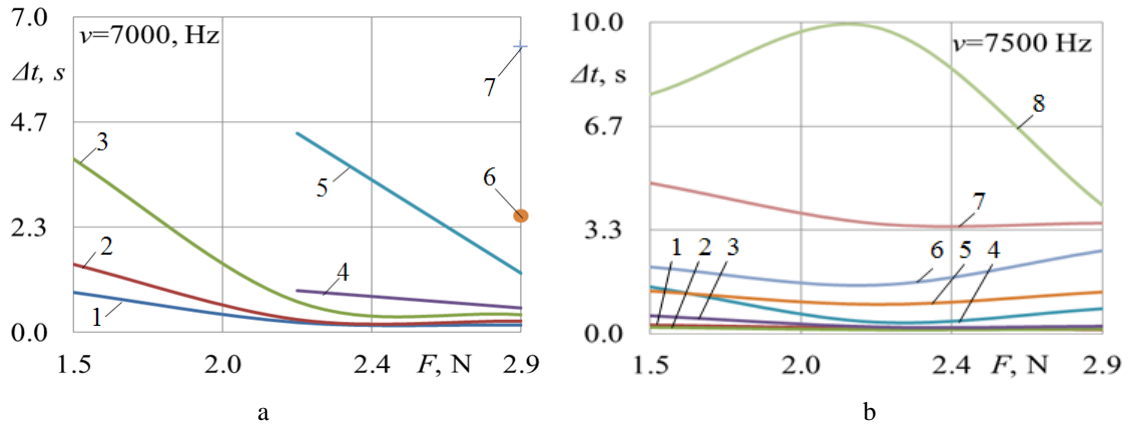

Fig. 11 Alignment duration dependency on initial pressing force F : a – peg without chamfers; b – peg with chamfers: 1 – $e = 0.4$ mm; 2 – $e = 0.6$ mm; 3 – $e = 0.8$ mm; 4 – $e = 1.0$ mm; 5 – $e = 1.5$ mm; 6 – $e = 2.0$ mm; 7 – $e = 2.5$ mm; 8 – $e = 3.0$ mm; 9 – $e = 3.5$

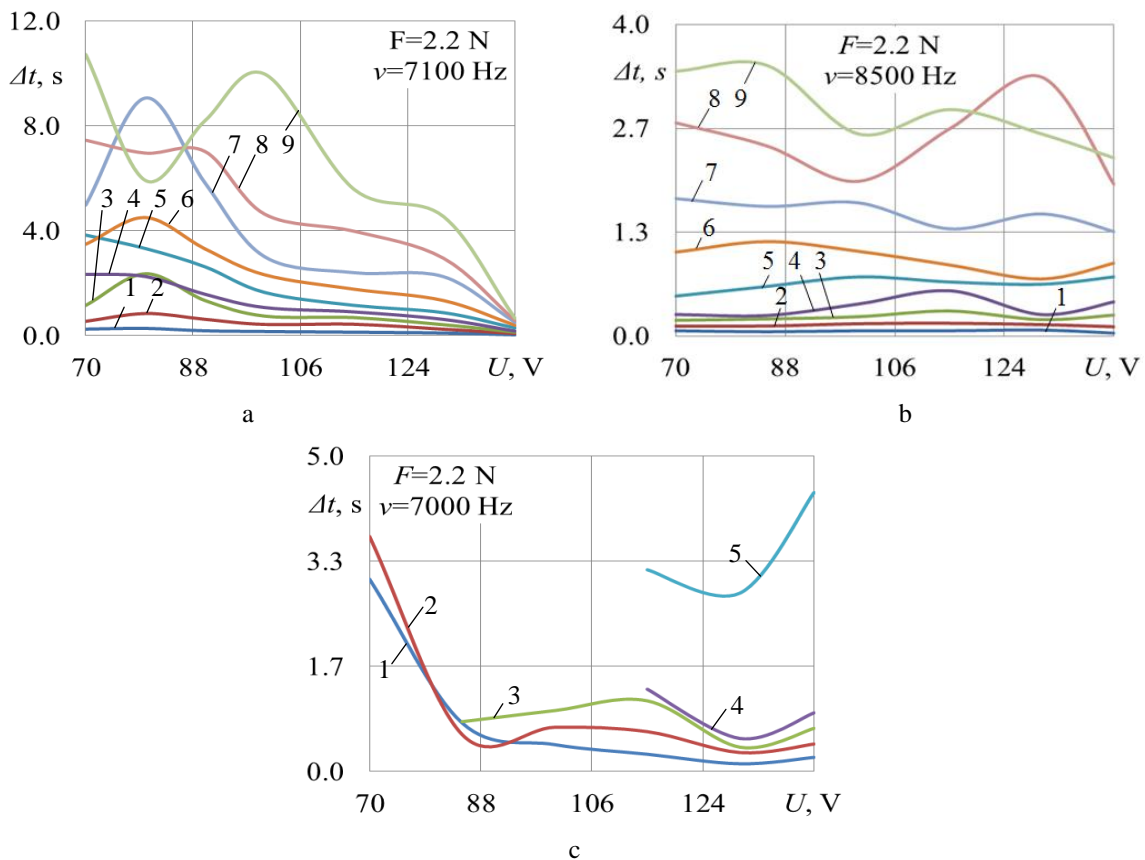

Fig. 12 Alignment duration dependency on excitation signal amplitude U : a – circular steel peg; b – circular aluminium peg; c – rectangular steel peg: 1 – $e = 0.4$ mm; 2 – $e = 0.6$ mm; 3 – $e = 0.8$ mm; 4 – $e = 1.0$ mm; 5 – $e = 1.5$ mm; 6 – $e = 2.0$ mm; 7 – $e = 2.5$ mm; 8 – $e = 3.0$ mm; 9 – $e = 3.5$ mm

starts after excitation signal amplitude reaches 100 V. Until that there are fluctuations in alignment duration.

With aluminium peg there are no obvious tendency of alignment duration change as excitation signal increases, Fig. 12, b. Only when axis misalignment is more than 2 mm alignment duration slowly decreases as excitation signal amplitude increases.

Results for the rectangular cross-section peg are shown in Fig. 12, c. If axis misalignment is less than 0.6 mm, alignment duration rapidly decreases until excitation amplitude reaches 85 V. Later alignment duration decreases slightly as excitation amplitude increases. When $e = 0.8$ mm alignment process starts only when excitation

amplitude reaches 85 V. With little variations alignment duration slowly decreases as amplitude increases. When axis misalignment is more than 0.8 mm alignment process starts after excitation amplitude reaches 115 V. If axis misalignment is 1.0 mm, alignment duration decreases as excitation amplitude increases. If axis misalignment more than 1.0 mm, alignment duration is fastest at excitation amplitude $U = 130$ V. Later alignment duration increases as excitation amplitude increases.

4. Conclusions

1. Experimentally was approved that it is possible

to do part alignment using elastic vibrations when peg is excited in axial direction by mean of piezoelectric vibrator. Method is suitable for mutual alignment of the parts made from different materials and with different geometrical dimensions.

2. As axis misalignment increases, alignment duration also increases. Permissible axis misalignment for the chamfered pegs is larger than for the chamferless ones. In case with rectangular cross-section steel peg, maximum e that is possible to compensate is equal to the half of the short side at which direction part alignment is going.

3. In all cases exist excitation signal frequency at which part alignment is most rapid. As frequency value changes from it alignment duration increases or even stops. If axis misalignment is less than 0.8 mm, then influence of excitation frequency to the alignment duration is relatively small. Excitation signal frequency for aluminium peg is about 1 kHz higher than for the steel ones.

4. Influence of initial pressing force to the part alignment duration is relatively small when axis misalignment is up to 0.8 mm. Alignment duration decreases if initial pressing force increases when circular cross-section steel peg is used. If aluminium or rectangular cross-section steel pegs are used when alignment is fastest at 2.2 N initial pressing force.

5. If excitation signal amplitude increases, alignment duration decreases when chamferless steel peg is used. In case with chamferless aluminium peg excitation amplitude has no significant impact on alignment duration. Only when axis misalignment is more than 2 mm alignment duration decreases.

References

1. **Bright, G.; Deubler, C.** 1999. Design and implementation of an intelligent Remote Centre Compliance (IRCC) as a means of intelligent position feedback for a construction robot, International Symposium on Automation and Robotics in Constructions XVI, 719-723.
2. **Cheng, C.C.; Wu, B.Y.** 1997. Intelligent insertion assembly by fuzzy control rules, Proceedings of the 2nd Asian Control Conference, Volume 1, Seoul, 73-76.
3. **Pauli, J.; Schmidt, A.; Sommer, G.** 2001. Vision-based integrated system for object inspection and handling, Robotics and Autonomous Systems, 37: 297-309. [http://dx.doi.org/10.1016/S0921-8890\(01\)00161-0](http://dx.doi.org/10.1016/S0921-8890(01)00161-0).
4. **Newman, W.S.; Zhao Y.; Pao, Y.H.** 2001. Interpretation of Force and Moment Signals for Compliant Peg-in-Hole Assembly, International Conference on Robotics & Automation, Seoul, 571-576.
5. **Ciblak, N.; Lipkin, H.** 1996. Remote center of compliance reconsidered, Proceedings of The 1996 ASME Design Engineering Technical Conference and Computers in Engineering Conference, Irvine, 1-10.
6. **Chatpar, S.R.; Branicky, M.S.** 2001. Search Strategies for Peg-in-Hole Assemblies with Position Uncertainty, Proceedings of the 2001 IEEE/RSJ International Conference on Intelligent Robots and Systems, Maui, 1465-1470.
7. **Bakšys, B.; Ramanauskytė, K.** 2006. Motion of elastically and damping constrained part on a horizontally vibrating plane, Mechanika 6(62): 11-16.
8. **Bakšys, B.; Baskutienė, J.; Kilikevičius J.; Chada-roničius A.** 2010. Experimental analysis of the robotized assembly applying vibrations, Journal of Vibroengineering 4(12): 572-581.
9. **Archangelskyj, M.E.** 1996. About converting ultrasonic vibrations of the surface to the radial and linear movement of the body, Journal of Acoustics, vol. IX, 275-278 (in Russian).
10. **Mohri, N.; Saito, N.** 1994. Some Effects of ultrasonic vibrations on the inserting operation, London, The International Journal of Advanced Manufacturing Technology, 225-230. <http://dx.doi.org/10.1007/BF01751120>.

B. Bakšys, E. Sadauskas

VELENO-ĮVORĖS TARPUSAVIO CENTRAVIMAS NAUDOJANT TAMPRIUSIUS VIRPESIUS

Reziumė

Straipsnyje ekperimentiškai nagrinėjamas automatiškai renkamų veleno ir įvorės tarpusavio centravimas, naudojant tampriuosius virpesius. Velenas bazuojamas specialiaje griebtuve, o jo tamprieji virpesiai sužadinami iš galo prispaustu pjezovibratoriumi. Su įvore kontaktuojantis veleno galas virpa išilgine ir skersine kryptimis. Dėl to atsiranda įvorės poslinkis veleno atžvilgiu detalių ašių sutapdinimo kryptimi. Aprašyta tyrimo įranga ir eksperimento metodika. Išsiaiškinta detalių ašių nesutapimo, prispaudimo jėgos, žadinimo dažnio ir amplitudės įtaka centravimo trukmei ir šio proceso sėkmingumui, kai naudojamos skirtingų formų/dydzlių ir medžiagų detalės.

B. Bakšys, E. Sadauskas

ALIGNMENT OF THE PARTS USING HIGH FREQUENCY VIBRATIONS

Summary

In this paper experimentally analyzed mutual part alignment using elastic vibrations in automated assembly. The peg fixed in a gripper and elastic vibrations excited in longitudinal direction by mean of the pressed piezoelectric vibrator. The end tip of the peg vibrates in longitudinal and lateral directions in the contact point with the bush. It forces to move bush respectively to peg along the part alignment direction. Experimental setup and methodology explained. Influence of axis misalignment, initial pressing force and excitation frequency/amplitude to the stable and reliable alignment duration using parts from different materials with different shape/size has been determined

Keywords: alignment, elastic vibrations, peg-in-hole.

Received Mai 07, 2012

Accepted April 08, 2013